

Campground Master

Software Manual

Campground Master (tm) - Database: Main Operator: Administrator

File Reservations Customers Transactions Reports Maintenance View Log In/Out Help

Available only From: < 2/ 5/2003 > To: < 2/ 5/2003 > Reset / Today Show Range All Site Types

Rack	Arrivals	Departures	On Site	Unassigned	Non-Reserved	Payments Due	Transactions								
1	RVDx	Jones	Jones	Jones	Jones	Jones	Jones	Jones	Jones	Jones	Jones	Jones	Jones	Jones	Jones
2	RVDx	Alton	Alton	Alton	Alton	Alton	Alton	Alton		Bailey	Bailey	Bailey	Bailey	Bailey	Bailey
3	RVDx		Yeoman	Yeoman	Yeoman	Yeoman	Yeoman				Bailey	Bailey	Bailey	Bailey	Bailey
4	RV	Smith	Smith	Smith	Smith	Smith	Smith	Smith	Smith	Smith	Bailey	Bailey	Bailey	Bailey	Bailey
5	RV										Bailey	Bailey	Bailey	Bailey	Bailey
6	RV	Harvey	Harvey	Harvey	Harvey	Harvey	Harvey	Harvey	Harvey		Bailey	Bailey	Bailey	Bailey	Bailey
7	RV	Johnson	Johnson	Johnson							Bailey	Bailey	Bailey	Bailey	Bailey
8	RV	Childs	Childs	Childs	Childs	Childs	Childs	Childs	Childs	Childs	Childs	Childs	Childs	Childs	Childs
9	RV				Chrysler	Chrysler	Chrysler	Chrysler	Chrysler	Chrysler	Chrysler	Chrysler	Chrysler	Chrysler	
10	RV														
Cbn 1	Cabn				Weeks	Weeks									
Cbn 2	Cabn														
Cbn 3	Cabn														
Boat 1	Boat				Weeks	Weeks									
Boat 2	Boat														
Banq	Hall														
Crafts	Hall						Chrysler	Chrysler	Chrysler	Chrysler	Chrysler				
Stor 1	Stor				Chrysler	Chrysler	Chrysler	Chrysler	Chrysler	Chrysler	Chrysler	Chrysler	Chrysler	Chrysler	
Stor 2	Stor														
Stor 3	Stor	Childs	Childs	Childs	Childs	Childs	Childs	Childs	Childs	Childs	Childs	Childs	Childs	Childs	Childs

For Help, press F1 NUM

Campground Master[®]

User Manual and Reference

by Cottonwood Software

Version 11.0

Campground Master ® version 11.0

Copyright © Cottonwood Software 2020

All rights reserved. No parts of this manual or the accompanying software may be reproduced in any form or by any means - graphic, electronic, or mechanical, including photocopying, recording, taping, or information storage and retrieval systems - without the written permission of the publisher.

Products that are referred to in this document may be either trademarks and/or registered trademarks of the respective owners.

While every precaution has been taken in the preparation of this document, the publisher and the author assume no responsibility for errors or omissions, or for damages resulting from the use of information contained in this document or from the use of programs that may accompany it. In no event shall the publisher and the author be liable for any loss of profit or any other commercial damage caused or alleged to have been caused directly or indirectly by this document or the accompanying software.

The Campground Master software is the property of Cottonwood Software and is only available for use under license. The license is valid upon receipt of payment and proper registration information.

Campground Master has been thoroughly tested and designed to be fault-free. However, Cottonwood Software cannot be held responsible for any losses arising from the use of the software, and gives no guarantee as to the fitness of the software for a particular purpose. It is a condition of the license that the purchaser accepts all such risks; acceptance will be assumed when purchase is made or the license granted.

Campground Master is a registered trademark of Cottonwood Software.

Campground Master is licensed on a per-business-location basis.

A separate license is required for each business location, even if multiple locations are owned by the same person or company.

For the complete license agreement, refer to the subsequent section "Copyright and License Information"

Table of Contents

Chapter 1	Introduction	1
1.1	Overview - Software Purpose	1
1.2	Setup and Customization	1
1.3	If You Need Assistance	1
1.4	Copyright and License Information	2
1.5	PCI Compliance / PA-DSS Implementation	3
Chapter 2	Getting Started	5
2.1	Overview - Using This Manual	5
2.2	Terminology	5
2.3	System Requirements	6
2.4	Installing the Software	6
2.5	Running the Software	6
2.6	Logging In and Out	7
2.7	The Main Program Window	8
2.8	Tip of the Day	10
2.9	Helpful Hints --- Getting the Most Out of Your Keyboard and Mouse	10
	Right-click is your friend	10
	Keyboard shortcuts	11
	Data Entry Basics	13
	Copying and Pasting	14
Chapter 3	Setting Up Your Campground Database	15
3.1	Overview	15
3.2	Database Basics	15
3.3	Database Organization	17
3.4	Setup Checklist	18
3.5	Creating your Database	20
3.6	Park Information and Authorization Code	20
3.7	Operators and Access Levels	21
3.8	Pick-Lists	21
3.9	Customizing Data Table Fields	22
3.10	Shifts Functionality	22
3.11	Schedule Functionality	23
3.12	Site 'Dirty' Functionality	23

- 3.13 Sites 23
- 3.14 Maps 23
- 3.15 Taxes 24
- 3.16 Rates 24
- 3.17 Deposit and A/R Balances 24
- 3.18 Metered Electric, Gas and Water Support 25
- 3.19 File - Printing Options 25
- 3.20 File - Printer Setup 25
- 3.21 File - Print in Black & White 27
- 3.22 File - Fit to Page Horizontally 27
- 3.23 View - Toolbar 27
- 3.24 View - Status Bar 27
- 3.25 View - Color Keys 28
- 3.26 Import Data From Other Sources 29
- 3.27 Network Settings 29
- 3.28 View Product Authorizations 29
- 3.29 View - Minimize to the Taskbar Tray 29
- 3.30 Other Program Options 29

Chapter 4 Dynamic Interactive Report Screens 30

- 4.1 Overview 30
- 4.2 Common Controls and Settings 30
 - Overview 30
 - Date Selections 30
 - Site Type, Class and Park Selection 31
 - Site Filtering Dialog 31
 - Text Filtering -- Find Text Dialog 32
 - Report Options 34
 - Pop-up Tips 36
 - Right-Click and Double-Click Functions 36
 - Searching Reports 40
 - Sorting Reports 40
 - Sizing Reports 41
 - Printing Reports 41
 - Exporting Reports to Other Programs 42
- 4.3 Rack Tab View (Reservation Grid) 42
- 4.4 Rack Options 45
- 4.5 Map Tab View 47
- 4.6 Arrivals Tab View 49

4.7	Departures Tab View	49
4.8	On Site Tab View	50
4.9	Unassigned Tab View	51
4.10	Non-Reserved Tab View	51
4.11	Payments Due Tab View	52
4.12	Queries Tab View	54
4.13	Transactions Tab View	55
	Overview	55
	Detail Transaction Reports	55
	Filtering Transaction Reports	57
	Summary Transaction Reports	59
	Receipts by Category	63
Chapter 5	Working with Reservations	66
5.1	Overview	66
5.2	Starting a New Reservation	66
5.3	Reservation Types	66
5.4	The New Reservation Dialog	67
5.5	The Select Customer Dialog	75
5.6	Possible Duplicate Customers Found	76
5.7	Checking In	76
5.8	Checking Out	77
5.9	Transactions	78
5.10	Linked and Group Reservations	81
	Overview	81
	Linked Reservation Examples	82
	Managing Existing Reservation Linking	84
	Viewing Linked Reservations	86
	Creating Linked Reservations - Details	87
	Group Reservation Special Handling	90
5.11	Changing the Customer of a Reservation	90
5.12	Hourly / Scheduled Reservations	91
5.13	Monthly / Long-term Reservations	91
5.14	Day Passes	94
5.15	Making Changes to a Reservation from the Rack	94
	Overview	94
	Changing the Reservation Dates	95
	Changing Site Assignments	95
	Changing the Customer	96
	Canceling a Reservation	96

	Confirming a Reservation	97
	Confirmation Letters	98
	Guaranteeing a Reservation	98
	Splitting Reservations	100
	Managing Linked Reservations	102
	Synchronizing Linked Reservations	102
5.16	The Reservation Details Dialog	103
5.17	The Reservation Label Field	108
5.18	Managing Guests	109
5.19	The Notes Dialog	110
5.20	The Find Reservation Dialog	110
5.21	Reservations by Date Made	111
5.22	Unassigned Reservations	111
Chapter 6	Working with Customers	112
6.1	Overview	112
6.2	Adding Customers	112
6.3	Viewing and Editing Customer Information	114
6.4	The Find Customer Dialog	116
6.5	Merging Customers	118
6.6	Customers with Warning Flags	118
6.7	Deleting a Customer	119
Chapter 7	Working with Transactions	120
7.1	Adding Transactions	120
7.2	How Transactions Work	120
7.3	Transaction Types	121
7.4	Recommended Transaction and Reporting Procedures	124
7.5	The Transactions Dialog	128
	Using the Transactions Dialog	128
	Auto-Rates	132
	Entering Individual Transactions	134
	Overview	134
	Charge, Discount and Credit Transactions.....	134
	Tax Transactions.....	136
	Payment and Deposit Transactions.....	137
	Credit and Debit Card Payments.....	139
	Refunds	141
	Voiding Credit Card Transactions.....	142
	Transferring Deposits and Payments.....	143
	Grid-Entry Method.....	144
	Printing Receipts	144

	Receipt Types	146
	E-mailing Receipts	147
	Selecting Rates	148
	Back-dating Transactions	151
	Security Deposits	151
	Bounced Checks	151
7.6	Reservation Transactions	152
7.7	Customer Transactions	154
7.8	Unbound Transactions	154
7.9	Transaction History Dialog	155
7.10	Misc. Income and Expense Transactions	156
7.11	Monthly Billing	156
7.12	Find Receipt	161
Chapter 8	Other Reports	162
8.1	Overview	162
8.2	Report Dialog Controls	163
8.3	Housekeeping Report	166
8.4	Occupancy, Availability, Arrivals & Departures Statistics	167
8.5	How-heard Report	169
8.6	Unfulfilled Reservations	169
8.7	Date-Made Statistics Report	170
8.8	Meter Reading Reports	170
8.9	Meter History	175
8.10	Customer Mailing Labels, Envelopes and Other Forms	176
8.11	Customer and Reservation E-mail Lists and Batch E-mailing	177
8.12	Reservation Receipts and Forms	179
8.13	Reservation Filtering Dialog	179
Chapter 9	Alerts, Work Orders, Journal, and the Audit Trail	181
9.1	Overview	181
9.2	Alerts	181
	Overview	181
	Alert Dialog	181
	Viewing & Processing Alerts	182
	Alerts Options	182
9.3	Background Tasks (Threads)	182
9.4	Journal Entries	183
	Overview	183

	Viewing Journal Entries	183
	Viewing Details, Adding and Editing Journal Entries	184
9.5	Work Orders	184
	Overview	184
	Viewing Work Order Lists & Reports	185
	Viewing Details, Adding and Editing Work Orders	185
9.6	Audit Trail	186
	Overview	186
	Viewing the Audit Trail	186
	Audit Trail Filtering	187
	Audit Trail Options	187
Chapter 10	Import and Export Functions	189
10.1	Overview	189
10.2	Importing Customer, Reservation or Transaction Data	189
10.3	Exporting Reports and Data to Other Programs	193
10.4	Exporting Transactions to QuickBooks	194
	Overview	194
	Using the QuickBooks Export Function	195
	Taxes Mapping for Auto-taxes	200
	Transaction Categories Mapping	202
	Receipt Payment Methods Mapping	203
	Expense Payment Methods Mapping	204
Chapter 11	Online Reservations	205
11.1	Overview	205
11.2	Hercules (2-way integration)	206
	Overview	206
	Hercules 2-way Setup	207
	Overview & Check list.....	207
	Conversion from 1-way integration.....	209
	Data Fields.....	209
	Hercules Setup.....	210
	Hercules Setup - Operation.....	210
	Hercules Setup - Reservations.....	211
	Hercules Setup - Parsing.....	212
	Site Data Fields.....	213
	Amp Service Values Mapping.....	214
	Unit Types Values Mapping.....	215
	Adders Mapping.....	216
	Discounts Mapping.....	217
	Hercules Setup - Availability.....	217
	Hercules Setup - Connection.....	218
	Hercules Setup - Diagnostics.....	218
	Hercules 2-way Operations	219
	Overview	219

	Initial Synchronization.....	219
	Manual Mode.....	220
	Automatic Mode.....	221
	Online Reservation Handling.....	222
	Viewing Recent Online Reservations.....	223
	Possible Duplicate Customers Found.....	224
	View Diagnostics Window.....	224
	Send/Request Full Synchronization.....	224
	Unlock All Sites.....	224
	Error Handling.....	225
11.3	Other Online Interfaces Setup	228
	Overview	228
	Data Fields Used	229
	Setting Up for Export to Web	229
	Setting Up for E-mail Requests	230
	Connections & Options	231
	Online Connections - General Setup.....	231
	Online Connections - Export to Web.....	231
	Online Connections - E-mail Requests.....	232
	Online Connections - iCal.....	233
	Online Setup - Site Data Fields	234
	Online Setup - Parsing Sets	236
	Overview	236
	Setup Parsing Sets Dialog.....	237
	Edit Parsing Set Dialog.....	238
	Save and Test Parsing Set.....	239
	Edit Parsing Rule Dialog.....	240
	Select a Data Field Dialog.....	241
	Parsing Rules Technical Details.....	241
	Parsing Set Example.....	249
	Web form example with parsing rules.....	249
	iCal File Support	249
	Overview	249
	Attaching iCal files to E-mail confirmations.....	250
	Setting up for Export to iCal files.....	251
	Exporting to iCal Files.....	251
	Setting up for Import from iCal files.....	252
	Importing iCal Files.....	252
	Setup iCal Profiles.....	253
	Edit iCal Profile.....	254
	Sample iCal Parsing Sets.....	258
11.4	Retrieving Online Reservations	259
	Overview	259
	Downloading Requests	261
	Processing Requests	262
	Online Request Details	264
	Uploading Site Availability Data	267
	Exporting to Web Vacancy Grids	267
	Sample Javascript to Insert Form Values	270
	Sample Web Reservation Form	271

Chapter 12	Maintenance Functions	272
12.1	Overview	272
12.2	Back Up and Restore Database	272
12.3	Restoring from a Backup	274
12.4	Rename Database	275
12.5	Check for Updates	275
12.6	E-mail database and logs to support	276
12.7	Park Setup Functions	276
	Overview	276
	Parks Setup	277
	Sites Setup	279
	Add/Insert Multiple Sites	281
	Edit Site Details	281
	Taxes Setup	287
	Rates Setup	291
	Overview	291
	Rates Setup Dialog.....	291
	Rate Types.....	292
	Edit Rate Definition Dialog.....	294
	Auto-Rates Setup.....	301
	Auto-Rates proper order example.....	303
	Rate Setup Examples.....	305
	Deposits Setup	316
	Overview	316
	Deposits Setup Dialog.....	316
	Deposit Types.....	318
	Edit Deposit Dialog.....	319
	Operator Setup	321
	Access Levels Setup	324
	Maps Setup	325
	Overview	325
	Maps Setup Dialog.....	325
	Edit Map Dialog.....	326
	Add/Edit Site Indicator Dialog.....	332
	Add/Edit Hotspot Dialog.....	332
	Schedules	333
	Reservation Restrictions & Reminders	335
	Overview	335
	Restrictions Setup Dialog.....	336
	Restriction Types.....	338
	Edit Restriction Dialog.....	339
12.8	Setting up for Electric, Gas, and Water Meters	342
12.9	Pick Lists	345
12.10	Data Field Definitions	350
12.11	Site "Dirty" Functionality	354

12.12	Program Options	355
	Overview	355
	Format Options	355
	Function Options	357
	Prompt Options	360
	Transactions Options	361
	Reservation Options	362
	Reservation Default Values	364
	Duplicate Customer Checking	365
	Auto-Rates Options	365
	Zip Codes	367
	Monthlies Options	368
	Database Options	369
12.13	Printing Options	370
	Overview	370
	Reports Settings	370
	Receipts Settings	371
	Reservations Settings	373
	Credit Card Settings	374
	Offsets Settings	375
12.14	Notice Messages, Confirmation Letter and Window Tag text	376
12.15	Receipt Printer USB/Driver Settings	377
12.16	Receipt Printer Direct to Port Settings	379
12.17	Cash Drawer Setup	380
12.18	Credit Card Processing	382
	Overview	382
	Processing Software Options	382
	Hardware Setup	383
	Processing Setup Options	384
	Basic Setup - X-Charge	386
	EMV Field Selections	389
	Debit Options	389
	Basic Setup - Cayan MerchantWARE Web	390
	Basic Setup - MCPS (Merchants' Choice)	392
	PCCharge	393
	ICVerify	394
12.19	Credit Card Security Setup	394
12.20	Credit Card History / Security Cleanup	395
12.21	Remove a Customer's Credit Card Information	395
12.22	Online Setup	396
12.23	E-mail Setup	396
	Overview	396

	SMTP Setup	396
	Send E-mail (Preview)	401
	Batch E-mailing options	402
	Confirmation E-mail Text & Options	403
	Invoice, Receipt and Statement E-mail text	403
	E-mail Form Customization and HTML E-mail	404
12.24	Shift Report	405
12.25	Shift Change	405
12.26	New Database (create a new database file)	406
12.27	Purge Old Data	406
12.28	Raw Data Tables	409
12.29	Database Maintenance	410
	Overview	410
	Deposit Balance Adjustment	411
	A/R Balance Adjustment	411
	Report and repair Orphaned Transactions	411
	Report and repair Orphaned Reservations	412
	Report Conflicting Reservations	412
	Report Unmatched Transfers	413
	Repair <bad links>	413
	Show the current database location	413
	Move the database to Shared or Public Documents	413
12.30	Copying To a New Computer	414
12.31	Recovering a Database from an Alternate Hard Drive	417
12.32	Multiple Databases on One Computer	419
12.33	Advanced Customizations	421
	Overview	421
	Tab Views Setup	422
	Expressions	425
	Overview	425
	Expression Syntax.....	425
	Expression Context.....	430
	Expression Processing.....	431
	Expression Creator Dialog.....	432
	Expression Elements Dialog.....	433
	Macros	436
	Scripts	438
	Function Reference.....	442
	Function Types.....	442
	Context (This.....)	442
	Conversion.....	442
	Database.....	442
	Database Modification.....	442
	Date & Time.....	442
	Financial.....	442
	Flow.....	443

- General & System..... 443
- Inspection..... 443
- Math..... 443
- Settings..... 443
- Text..... 443
- User Interaction..... 443
- User-defined Dialogs..... 443
- FormatDateTime specifications..... 443
- FormatInt and FormatFloat specifications..... 443
- Color Schemes 444**
- Default Global Color Schemes 447**
- Queries 448**
 - Overview 448
 - Queries Setup..... 449
 - Editing List Queries..... 449
 - Editing Query Columns..... 452
 - Sorting Hierarchies..... 455
 - Filter Conditions..... 456
 - Save & Test Query..... 458
 - Editing Cross-Table Queries..... 458
 - Cross-Table Axis/Groupings..... 462
 - Cross-Table Custom Groupings..... 466
- Forms 467**
 - Overview 467
 - Forms Setup..... 467
 - Importing and Editing Sample Forms..... 469
 - Editing Forms..... 470
 - Form Elements List..... 475
 - Editing Form Elements..... 476
 - Form Selection Dialog..... 485
- Menus 485**
 - Overview 485
 - Menus Setup..... 486
 - Editing Menus..... 487
 - Menu Items List..... 489
 - Editing Menu Items..... 490
- Dialogs 493**
 - Overview 493
 - Dialogs Setup..... 494
 - Editing Dialogs..... 495
 - Dialog Elements List..... 497
 - Editing Dialog Elements..... 498
 - Dialog Control ID Reference..... 505
 - Base Dialogs ID Reference..... 505
- Event Actions 506**
 - Overview 506
 - Event Actions Setup..... 506
 - Editing Event Actions..... 506
- User-defined Tables 509**
 - Overview 509
 - Tables Setup..... 509
 - Editing Tables..... 511
 - The "Record List" Dialog..... 512

The "Edit Record" Dialog.....	512
User-defined Relationships	513
Overview	513
Relationships Setup.....	514
Editing Relationships.....	514
Import Package	516

Chapter 13 Network Functions 517

13.1 Overview	517
13.2 Setting up for a Network	517
13.3 Network Troubleshooting Tips	521
13.4 Setting a Static IP in Windows	523
13.5 Networking through the Internet	524
13.6 Setting up Multiple Connections or Databases	526
13.7 Changing the Master Computer	528
13.8 Network Setup Dialog	529
13.9 Connecting Progress Dialog	532
13.10 Request a Full Database Refresh	532
13.11 Full Network Resynchronization	533
13.12 Other Network Functions	535
13.13 Net Client Diagnostics Dialog	536
13.14 Net Server Diagnostics Dialog	537
13.15 How Networking Works	537
13.16 Firewall Configuration	539
Firewall Basics	539
Windows Firewall	539
ZoneAlarm	539
McAfee	540
Norton	540

Chapter 14 Point of Sale 541

14.1 Overview	541
14.2 P.O.S. Functions	542
Overview	542
Sales Entry -- Point of Sale Dialog	542
Returning POS items	547
Sales Entry - Enter Item Price	548
Sales Entry - Enter Item Qty	548
Selecting a Reservation or Customer	548
Find P.O.S. Receipt	549
Find Inventory Item	549
Inventory Filter	550

	Inventory Reports	550
	Overview	550
	Inventory List Reports.....	551
	Inventory Sales Reporting.....	552
	On-Hand Report.....	553
	Cost of Goods Sold report.....	555
	Adjustment Detail Report.....	557
	Adjustment Summary Report.....	558
	Purchase Orders	559
	Overview	559
	Create Purchase Orders.....	560
	Print Purchase Orders.....	562
	Find / Print Purchase Orders.....	563
	Purchase Order Filter.....	563
	Purchase Orders Outstanding (Receiving).....	563
	Print Vendor Labels & Envelopes.....	564
	Entering Inventory Adjustments	565
14.3	P.O.S. Setup	568
	Overview	568
	Hardware Selection	569
	Pole Display Setup	570
	Program Options - P.O.S.	572
	Printing Options - P.O.S. Receipts	574
	Printing Options - Purchase Orders	575
	P.O.S. Data Fields	576
	P.O.S. Access Levels	577
14.4	Inventory Setup	577
	Overview	577
	Inventory Classes & Transaction Categories	577
	Vendors	578
	Item Discounts	579
	Overview	579
	General Discounts Setup.....	581
	Editing Discounts.....	581
	Adding and Editing Inventory Items	585
	Importing Inventory and Vendor Data	590
	Filter inventory sales lookup	593
	Index	595

1 Introduction

Overview - Software Purpose

The Campground Master software was designed to simplify the task of reservation management for any campground, RV resort or other rental/hospitality business. It was designed to be fast and easy to use for both large and small campgrounds, while supporting all of the features expected in a reservation management system. In addition to keeping track of reservations (including the current and past status of all rental sites), the software keeps a detailed customer database and a complete log of all financial transactions for each customer and rental site. The information can be used to generate helpful financial reports and occupancy reports, show marketing results (where your customers come from), and more.

Setup and Customization

Many aspects of the software are user-definable, and everything can be set up by the end user through the program's menus. No programming knowledge is necessary for the basic functionality, although a familiarity with the Windows operating system and basic software use is recommended. This manual covers every function of the software, including the maintenance functions used for setting up the database for your business.

For more information, see the section *Setting Up Your Campground Database*.

If You Need Assistance

You can contact Cottonwood Software at:

E-mail: support@campground-master.com

Web: <http://www.campground-master.com>

Phone: 1 (913) 522-0717

Limitations of support:

While we pride ourselves in the depth and availability of our support, which goes far beyond even the expensive support available with most software companies, we must make certain reasonable disclaimers.

We will do our best to answer any questions and solve operational problems, and provide limited training on functions of our software. However we cannot provide extensive configuration services or comprehensive training, or provide support for basic Windows functionality, 3rd-party software, or hardware not purchased from us. Since Campground master is sold as a do-it-yourself program, we do expect the user to fully read the documentation and make an earnest attempt to do the setup or solve a problem themselves before requesting support.

Support is included only for the original purchaser or licensee of the software. If your business changes ownership, management or primary software users, and such a change results in excessive support to the new users in the basic functionality or setup again, then we may require a new license to be purchased or a transfer fee in order to continue support.

We reserve the right to refuse support to users who in our judgment are abusive or have unreasonable expectations, or who have system or other difficulties making satisfactory support impractical. (A refund will be issued if this occurs within 90 days of purchase.)

Specific exclusions: Advanced Customizations functions included in the program are present for the purposes of custom programming. While these are available and documented for potential use by 3rd party programmers, they are not designed to be used by the typical end user. Any support for these functions

beyond answering simple questions about them will be considered custom development and thus not covered by normal support.

Copyright and License Information

All rights are reserved. No part of this manual or software may be copied, sold, loaned, translated or reduced to any electronic medium, in whole or part, without the prior written permission of Cottonwood Software.

This End User License Agreement (the "Agreement") is a legally binding agreement between you (either an individual or an entity, the "User"), and Cottonwood Software, LLC regarding the Campground Master software (the "Software" or the "PRODUCT"), and b) all successor upgrades, revisions, patches, fixes, modifications, copies, additions or maintenance releases of the Software, if any, licensed to you by Cottonwood Software, LLC (collectively, the "Updates"), and c) related user documentation and explanatory materials or files provided in written, "online" or electronic form (the "Documentation" and together with the Software and Updates, the "Distribution Package").

CAREFULLY READ THE FOLLOWING LEGAL AGREEMENT. USE OF THE PRODUCT PROVIDED WITH THIS AGREEMENT CONSTITUTES YOUR ACCEPTANCE OF THESE TERMS. IF YOU DO NOT AGREE TO THE TERMS OF THIS AGREEMENT, DO NOT INSTALL AND/OR USE THE PRODUCT. YOUR USE OF THE PRODUCT IS CONDITIONED UPON COMPLIANCE WITH THE TERMS OF THIS AGREEMENT.

1. Intellectual property rights

The PRODUCT is owned and copyrighted by Cottonwood Software, LLC and is only available for use under license. The license is valid upon receipt of payment and proper registration information. Campground Master has been thoroughly tested and designed to be fault-free. However, Cottonwood Software cannot be held responsible for any losses arising from the use of the software, and gives no guarantee as to the fitness of the software for a particular purpose. It is a condition of the license that the purchaser accepts all such risks; acceptance will be assumed when the software is installed.

The Software and any documentation included in the distribution package are protected by national copyright laws and international treaties. Any unauthorized use of the PRODUCT shall result in immediate and automatic termination of this license and may result in criminal and/or civil prosecution.

Your possession, installation or use of the PRODUCT does not transfer to you any title to the intellectual property in the PRODUCT, and you will not acquire any rights in the PRODUCT except as expressly set forth in this Agreement.

2. Scope of the License

The software as downloaded from the internet may be used in "Demo mode" or with a "Trial" authorization code provided by Cottonwood Software without payment and without restriction.

Campground Master is licensed on a per-business-location ("property") basis.

Upon payment of the license fees, you are granted a non-exclusive license to use the PRODUCT as set forth herein, for a single property. A property is defined as a physical location operating under a single name. If a business owns multiple properties operating under different names or at different locations, a separate license is required for each property using the PRODUCT. If the property is sold to another entity, the license remains valid for that business location only, and therefore cannot be used for another property, either concurrently or subsequently.

The licensed PRODUCT may not be rented or leased, but may be permanently transferred together with the accompanying documentation, to a new owner of the same property that it was originally purchased for, if the new owner of the property receiving it agrees to terms of this license. There is a transfer fee required in order

for the new owners to receive support. The license may not be transferred to another property under any circumstances, even if the original property is no longer in business or existence.

You agree not modify, decompile, disassemble, otherwise reverse engineer the licensed PRODUCT, unless such activity is expressly permitted by applicable law.

3. Authorization code

Authorization code - a unique identification code provided to you by Cottonwood Software confirming the purchase of the license from Cottonwood Software, which may carry the information about the license and enable the full functionality of the PRODUCT in accordance with the Agreement.

The Authorization Code provided to you by Cottonwood Software constitutes confidential proprietary information of Cottonwood Software. For purposes hereof, you agree not to transfer, copy, disclose, provide or otherwise make available such confidential information in any form to any third party without the prior written consent of Cottonwood Software. You agree to implement reasonable security measures to protect such confidential information provided to you by Cottonwood Software.

4. Limited warranties

COTTONWOOD SOFTWARE DOES NOT WARRANT THAT THE SOFTWARE IS FIT FOR ANY PARTICULAR PURPOSE. COTTONWOOD SOFTWARE DISCLAIMS ALL OTHER WARRANTIES WITH RESPECT TO THE SOFTWARE, EITHER EXPRESS OR IMPLIED. COTTONWOOD SOFTWARE IS NOT RESPONSIBLE FOR ANY LOSSES ARISING FROM THE USE OF THE PRODUCT. SOME JURISDICTIONS DO NOT ALLOW THE EXCLUSION OF IMPLIED WARRANTIES OR LIMITATIONS ON HOW LONG AN IMPLIED WARRANTY MAY LAST, SO THE ABOVE LIMITATIONS OR EXCLUSIONS MAY NOT APPLY TO YOU.

5. Final provisions

All rights not expressly granted here are reserved by Cottonwood Software.

PCI Compliance / PA-DSS Implementation

Introduction

In order to address the growing national and international concern for securing credit card information, Visa began to develop standards and announced the Cardholder Information Security Program (CISP) in April, 2000. These standards became required in June, 2001, for all entities that store, process or transmit Visa cardholder data.

Since that time, other credit card companies have become involved, and a new group called the Payment Card Industry Security Standards Council was formed to standardize security requirements across the entire credit card industry. The result is a new security standard called Payment Card Industry Data Security Standard (PCI-DSS or simply 'PCI') which is designed to ensure standardized compliance for multiple associations.

This document is provided to guide users of Campground Master into becoming and remaining PCI compliant.

Why you need to be concerned about this

Credit Card companies are requiring compliance with PCI standards for every entity that is involved in the storage, processing, or transmission of credit card information. Failure to comply can result in denial or revocation of your organization's ability to process credit cards.

Furthermore, as these standards have become widely recognized, non-compliance places your organization at risk of legal and/or civil consequences if credit card information becomes compromised.

Compliance with PCI standards is necessary whether or not you use Campground Master to process transactions "online." Even if you use a POS terminal or other method to process transactions, and simply retain information in Campground Master, you must be concerned about proper use of the program to maintain security and confidentiality of customer data.

Complete Implementation Guide

The complete details and guide to implementing Campground Master in a PCI (PA-DSS) compliant manner can be found in the online help (Help / Help Topics in the program, under Introduction), or as a separate document on the CD-ROM.

2 Getting Started

Overview - Using This Manual

The information in this manual varies from the very basic to the highly complex. If you are not comfortable with using Windows software, you should start by going through the Quick Start guide with the software, and then read the *Terminology* and *Helpful Hints* sections thoroughly before proceeding. You may also want to skip the *Setting Up...* and *Program Options...* sections and start at *The Dynamic Interactive Report Screens* section for more basic program information.

If you are a seasoned Windows user, you can probably skim these sections and dig right in to the *Setting Up Your Campground Database* section. The Quick Start guide is still recommended as a quick introduction to how the software works, however.

It is highly recommended that you have the software running on your computer and actually use it as you read this manual. You can then experiment with the functions as they are described. This is the fastest way to learn the software. Once you actually do it yourself, you will remember it much better than just having read about it.

WARNING - You will probably *not* want to use the real database for experimenting -- either use the sample database that comes with the software, or make sure you have a *backup* before making any changes, and know how to do a *restore* from the backup once you are finished experimenting.

Terminology

This manual assumes that you are familiar with general computer and Windows terminology, such as keyboard, mouse, window, button, menu, and so forth. Here are a few terms specific to the Campground Master software that are used extensively in the manual.

Tabs -- Besides the Tab key on the keyboard, "Tabs" refers to the row of buttons on the main Campground Master screen that simulate section tabs in a notebook or day-planner. They bear the words "Rack", "Arrivals", "Departures", etc., and are used to change to different views, or dynamic interactive reports (for example, click on the "Payments Due" tab to see the Payments Due view).

Views or **Tab Views** -- Officially known as *Dynamic Interactive Reports* in Campground Master, the different sets of data that appear on the main screen corresponding to the Tabs (see above) are called Views throughout the manual, for simplicity. For example, the *Rack View* is the primary screen with the reservation "rack" dynamic interactive report.

Grids and **Cells** -- Each of the Views consist primarily of a Grid with data Cells. In other words, a grid consists of rows and columns of information, and a cell is any one of the row/column positions. While some data cells may be different sizes to accommodate the data, any structure with rows and columns is considered a grid. These will also appear on some dialogs and report screens. A grid is usually easy to identify since the grid lines are visible, but the lines can be turned off on some views if preferred.

Dialog -- This is a general Windows term, but not commonly used except by programmers. A dialog is any of the pop-up windows that appear to alert the user or ask for input, such as an "Are You Sure" prompt or a customer entry form.

Prompt -- This is a more specific term for a simple dialog that has a message or a question to be answered, and usually a few buttons such as OK, Cancel, Yes, or No. These are usually warnings that the user should read carefully before continuing.

Right-click -- This is a term for clicking the right mouse button (instead of the left button which is more commonly used).

Double-click -- This means click the left mouse button twice in quick succession. It's important to not move the mouse at all between the clicks, or else it will be seen as two separate clicks instead of one double-click action, and the results will be different. (This is a common problem among beginning computer users that takes quite a bit of practice to correct).

Default -- The terms "by default" or "default setting" don't have anything to do with a "fault". It means that the selection has a pre-set, or normal, condition unless the user selects a different one. For instance, the Rack view is the "default view", which means it will be the view shown unless the user clicks on a tab to choose another view.

System Requirements

Campground Master is designed to operate on any PC that can support Windows 95 or later. Generally any computer manufactured after 1996 will work, however following the recommendations below will allow for smoother operating and better functionality (for instance, more features are available when 800x600 or better screen resolution is used, colors look much better on a true-color display, a lot more data can be kept before a Purge is needed if you have more RAM, etc.).

Requirements:

Microsoft Windows 32-bit or 64-bit operating system (e.g. XP, Vista, Windows 7, 8 or 10).
512MB RAM or more (2GB recommended for NT/XP, 4GB+ for Vista or Windows 7, 8 or 10)
640x480 graphics (1024x768 or higher recommended)
50MB free hard disk space for minimal database, 1GB recommended

Installing the Software

If you have the software on CD-ROM it is basically self-installing. Simply insert the CD-ROM and the installation will start automatically. If installation does not start automatically, follow this procedure:

1. Insert the CD-ROM into the CD-ROM drive.
2. From the Windows **Start** menu, select **Run...**
3. Type **d:\setup** in the edit box, where "d:\\" is your CD-ROM drive letter.
4. Press **Enter**.

If you have obtained the software in an electronic form (e.g. a download from the Internet), then simply Run the downloaded "install" file to start the installation.

The installation program should start and ask you to confirm the selections. Just click the **Next** button on each prompt to continue, and the software will install in the typical way most users need.

Running the Software

When installing the software, you will have the option to have Campground Master start up automatically when you start your computer. In addition, an icon will be placed on the Windows desktop so you can start or restart the software any time by double-clicking the icon. (For those who have trouble with double-clicking the mouse button, you can also click an icon once and then press the **Enter** key to start the program.)

Note: You may see three icons for the program, in which case two of them will be labeled "Demo" -- one with POS (Point of Sale) and one without. These icons can be used to start the software with the sample database, which can be useful for experimenting. Once the software is in full use, these demo icon should be deleted to avoid confusion.

Using the Sample Database / Demo

If you're just trying the free demo at this point, then use one of the "Demo" icons to run the program. You won't need to log in, and you can start working through the Quick-Start Guide to learn the basic functions. It's a good idea to keep reading through the rest of this "Getting Started" section first, though, especially if you're not a computer expert already.

Starting your own Database

If you've purchased the program or have a 30-day trial authorization code and you're ready to set it up with your own data, then you'll want to first continue reading through this "Getting Started" section, especially if you're not a computer expert already. Then if you haven't worked with the Demo (sample database) yet, please spend a little time getting familiar with that first (see above). Finally, when you're ready to tackle the setup yourself, see "Setting up Your Campground Database", especially the Setup Checklist.

Logging In and Out

Once the program starts, you will be asked to Log In with an Operator Login and Password. This is necessary to access any of the program's functions. The software initially has one operator with administrative access (able to do everything), so you can log in with the operator name "**Administrator**" and the password "**Password**". (Type them without the quotes.) The first time you use this login, it will require you to change the password -- don't forget what you change it to!

To log in, just follow these steps:

1. Click the Log In button on the toolbar (the key icon) or click on Log In/Out on the main menu.
2. Type your operator login name. Don't worry about whether to use capital letters or not, it doesn't matter.
3. Press the **Enter** key (or **Tab** key) to move to the Password field.
4. Type your password. Again, don't worry about capitals. Note that you won't be able to see the letters you type -- they will all be shown as asterisks (*). This is for security. If you make a mistake, it's best to back up to the beginning with the **Backspace** key and start over.
5. Press the **Enter** key (or click on the Log In button with the mouse).

You should now be logged in. If you get an error message, you can go back and try again.

Once you're logged in, you should see more of the toolbar icons enabled (in color), and you can click on the tabs (Arrivals, Departures, etc.) to change views.

Logging Out

When you want to log out of the system (to prevent others from gaining access and changing data), just open the Log In/Out dialog as above and click the Log Out button.

Changing Your Password

To change your password, just open the Log In/Out dialog as above and click the Change My Password button. You will be required to enter your current password, and then enter a new password twice for verification (since the passwords are not visible when typing). Note that you cannot change your password to any that has been used within 4 previous changes.

Forgot Password?

If you attempt to log in and enter an incorrect operator or password (and nobody is currently logged in), then a "Forgot Password?" button will be available. This function will allow you to send a request to support for a temporary login, so you can get in to Operator Setup to manage the operator logins. Note that this is the preferred method of contacting support if you are unable to log in, and is faster than calling.

The Main Program Window

Caption / Title Bar



This is the standard Windows caption used by nearly all Windows programs. Besides the name of the program, the Campground Master caption has a few informative items in it.

Database name -- You will likely be using the same database at all times, so the database name will probably be the name of your campground (or whatever name you gave your database). If you do change databases, for instance to manage multiple campgrounds, this will tell you at a glance which one you're working with.

Change indicator -- If an asterisk (*) appears next to the database name, this means that the database has been changed and not yet Auto-saved to disk.

Operator -- The currently logged in operator is shown, so you can tell whether or not you're operating under the correct log-in.

Workstation and network status -- If you're authorized for the networking version, the caption will also show the workstation ID and (optional) nickname for this workstation, plus the network status (Master or Client configuration, and if it's a client, whether it's connected or not). For example: **Workstation: Store [1] (Client, Connected)** -- this indicates that it's workstation ID 1, nicknamed "Store", and that it's a client currently connected to the master.

Window control buttons -- These are the standard Windows buttons to minimize, maximize/restore, and close the window. If you've used Windows programs before, you should be familiar with these.

The first button, which looks like an underline character (_), will minimize the window (shrink it to a button on the Windows task bar). To get it back after minimizing it, just click on its task bar button.

The second button that looks like a box will either be Maximize or Restore, depending on the current state of the window. Clicking on it once will enlarge (Maximize) the window to fill the entire screen, and clicking it again will restore the window to a smaller size. In most cases, you will want to keep the window maximized so you can see as many reservations as possible in the Rack view..

The last button, (X), will shut down the program (same as selecting Exit from the File menu).

Main Menu

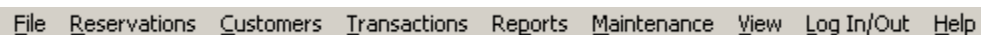

The main menu is always at the top, just under the program caption. It contains all of the main functions of the program and is fairly self-explanatory (each function is detailed elsewhere in this manual).

Toolbar



The toolbar is the row of picture icons below the menu. (It can be turned on and off from the View menu.) The Toolbar can be used for quick access to the most common top-level functions. Each of the functions are also available as Menu commands and as function key shortcuts (**F2** through **F8**), so you can turn off the toolbar without losing functionality if you prefer using the menu or if you're comfortable with the keyboard shortcuts. The icons will normally be shown in color, but will be gray if the option is disabled. For instance, all but the Log-in button will be gray until an operator is logged in.

New Reservation (Phone) -- This will open the New Reservation dialog, the same as the menu selection Reservations / Add New Reservation.

New Customer (Faces) -- This opens the customer editing dialog, the same as the menu selection Customers / Add New Customer. It's handy for adding new customers or for looking up customer information (you can use the Find button on the dialog immediately without adding a new customer).

New Transaction (Cash register) -- This opens either the New Transaction dialog, Unbound Transactions, or the Point of Sale, depending on the Program Options settings. It's most useful for entering transactions like counter sales, expenses, or other income.

Save Database (Diskette) -- This will instantly save the database, the same as the menu selection File / Save. This button will be gray (disabled) if you have the Auto-save option enabled, and you should have that option enabled at all times.

Backup Database (Safe) -- This will create a backup copy of the database, the same as the menu selection Maintenance / Back Up Database. You should make a backup at least once per day, and this button will help you remember to do that since it's right next to the Log-in button.

Log In/Out (Key) -- This is used to log an operator in our out, the same as the Log In/Out menu selection.

Print (Printer) -- This will print the currently visible tab view, the same as the menu selection File / Print (or File / Print Preview if the Always Preview option is enabled).

Search (Magnifying glass) -- This opens the Search function, which allows you to search the current tab view for a site name or customer name. This function has no menu equivalent, but can also be invoked with the **F9** key or **Alt-S**. To search the entire database for a customer or reservation, instead of just searching the current tab view, use the Find Customer and Find Reservation menu functions.

Tab Views (Dynamic Interactive Reports)



This is the main portion of the screen, where most of the action is. It will fill the remainder of the window between the toolbar and status bar (if present), regardless of the window size. The "tabs" are like file folder labels across the top of the views -- just select the report you want to view by clicking on its named tab. The one being viewed will be highlighted with bold text. The image above shows a typical configuration (currently showing the Rack view), although the tabs are configurable if desired. The operation of each Tab View is discussed in detail in the *Dynamic Interactive Report Screens* section.

Status Bar

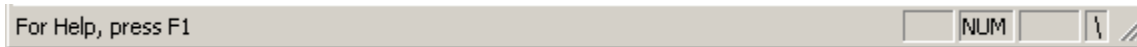

The status bar appears at the very bottom of the window, and can be turned on and off from the [View](#) menu. It simply shows short help-hints for menu items (whatever the mouse cursor is hovering over), some progress messages (for instance, "Saving database"), and the state of keys like **Caps Lock** and **Num Lock**.

If you're running the networked version, a small box will be shown at the right side with a heartbeat indicator. This indicator changes each time a message is sent or received over the network, indicating that it's connected and functioning. (The character shown is meant to simulate a spinning propeller, in case you're wondering.) If the network connection is not functioning, an "X" will be shown.

Tip of the Day

Each time you start Campground Master, a Tip of the Day window will appear. This presents the user with a helpful tip each day (or each time the program starts). There are over 100 program usage tips covering different shortcuts, special functions, and brief tutorials. Some tips will show "New Feature" in the upper right corner, alerting you to a feature recently added. So even if you've reviewed all of the tips before, it's a good idea to turn the tips back on when you upgrade to a new version of the software.

If you don't want to show the tips any more, uncheck the box [Show tips on startup](#). They can also be turned off (or back on) by going to the [Help](#) menu and selecting the [Show Tips on Startup](#) option.

The Help menu also has a selection to [Show Tips Now](#), so you can review them at any time. This will show the tips window immediately.

Note that for networked workstations, it remembers the last tip (and whether the tips are to be shown or not) separately on each workstation.

While the tips aren't listed in the printed manual, you can get a complete list through the Help (see this topic, under Getting Started / Tip of the Day, for a link). You can then print out the entire list for quick reference if you prefer.

Helpful Hints --- Getting the Most Out of Your Keyboard and Mouse

Right-click is your friend

Campground Master makes extensive use of the **right** mouse button to open "Context Menus". These are menus that contain quick-access functions for the object that you right-click on. For example, when looking at any of the main views you'll be able to right-click on a reservation to perform any functions appropriate for it at the time, such as checking in, changing sites, extending a reservation, and much more. The general rule is: right-click on everything, just to see what you can do.

Once you right-click to open the menu, the next click should use the **left** mouse button. In other words, the *only* time you need to use right-click is to *open* the context menu. Left-click does everything else. And once the menu is open, if you don't want to do anything on the menu then you can close it either by clicking somewhere else (*anywhere* else besides on the menu), or by pressing the **ESC** key on the keyboard.

For more details, see the Right-Click Functions in the *Dynamic Interactive Report Screens* section.

Keyboard shortcuts

There are several common Windows keyboard shortcuts that come in handy in Campground Master. Learning these can make you much faster at using the software, since moving the mouse and clicking takes time (and is often frustrating when you're trying to hurry and click in the wrong place!).

Function Key shortcuts

Instead of clicking on the toolbar icons, you can use a corresponding function key. Because **F1** is the standard key for Help in Windows programs, the toolbar icons correspond to F2 through F9:

- **F1** -- Help
- **F2** -- New Reservation
- **F3** -- New Customer (or Find Customer, depending on options settings)
- **F4** -- New Transaction (or Reservation Transactions, or P.O.S. / Unbound Transactions)
- **F6** -- Back up database
- **F7** -- Log in/out
- **F8** -- Print (this will also work on any dialog with a Print button)
- **F9** -- Search

While in the Transactions entry dialog (e.g. Reservation Transactions), these function key shortcuts are available:

- **F2** - Select Rates (or Auto-Calculate, if the auto-calculate button is present)
- **F3** - Enter Deposit
- **F4** - POS Sale (if POS option is present)
- **F5** - Enter Charge
- **F6** - Enter Cash Payment (Enter Payment, automatically selects Cash)
- **F7** - Enter Credit Card Payment (or Other Payment if credit card processing is not enabled)
- **F8** - Print
- **F9** - Open cash drawer
- **F10** - Done

Similar shortcuts are available in the Point of Sale Sales Entry dialog -- see that section of the documentation for details.

More Useful Shortcuts

These shortcuts to commonly used functions help minimize the need to go to the menus.

- **Ctrl-U** -- Find Customer
- **Ctrl-F** -- Find Reservation
- **Ctrl-Shift-F** -- Find Text. After started, **Ctrl-F3** to Find Next
- **Ctrl-R** -- Recall the last reservation created or viewed
- **Ctrl-T** -- Recall the last transactions entered or viewed
- **Ctrl-S** -- Search current view (same as F9 or Alt-S)
- **Ctrl-L** -- Look up Receipt (Find Receipt)
- **Ctrl-I** -- Find Inventory, only if P.O.S. option is enabled
- **Alt-.** (Alt-period) -- Point of Sale sales entry, only if P.O.S. option is enabled

Navigating the tab views with the Tab key and function keys

To quickly change the shown Tab View (assuming no other dialogs are open), you can either use the **Tab** key or **Shift-Function** keys. The **Tab** key will switch to the next one (press **Tab** repeatedly to cycle through them), and **Shift-Tab** will switch to the previous one. A more direct route is to use the function keys with **Shift** held down to switch directly to the corresponding view -- for instance, **Shift-F1** for the Rack view, **Shift-F2** for the Arrivals (or Map) view, and so forth.

Alt-key shortcuts to the menu and dialog buttons

Whenever you see a letter underlined in the top-level program menu (the "main menu") or on a button in a dialog, you can use the Alt-key with that letter instead of clicking on it with the mouse. For example, hold the **Alt** key down while pressing the "R" key to open the Reservations menu since the "R" is underlined. Once a menu is open (either one of the drop-down menus on the top or a right-click context menu), you can just press the associated letter without the Alt key. So to Add a Reservation, simply press **Alt-R** followed by the "A" key.

Windows XP note -- There's an option in XP to hide the underlines until you press the **Alt**-key. So if you don't see any letters underlined in the menu or dialogs then just press the **Alt** key and the underlines should show up. You can disable this option in XP by going into Desktop Properties (right-click on an empty desktop area), click the "Appearance" tab, click the "Effects" button, and uncheck the "Hide underlined letters" option. Then keep clicking OK to save everything.

Alternative to clicking "Save", "Done", "OK", "Close", and "Cancel" buttons

Most data entry and report dialogs have one or more of these buttons in the upper right, for closing the dialog. You can save time by using a couple keyboard shortcuts:

Save, Done, OK -- These buttons appear when there is an option to save any changes you've made. **Ctrl-Enter** will do the same as clicking Save, Done or OK.

Cancel -- The **ESC** key almost always does the same thing as clicking the Cancel button (also same as clicking the red "X"), which will close the dialog without saving changes (if changes have been made, it will prompt for confirmation).

Close -- This button is used when separate save or cancel options don't apply, for instance if there are no data entry fields to be saved. You can usually use either **ESC** or **Ctrl-Enter** to close the dialog.

Alternative to right-clicking on the tab views (advanced)

While the right-click can be your friend, there may be times when you would just rather not use the mouse. You can simulate the right mouse button with the "menu" key on the keyboard. This key is usually just to the left of the right-hand **Ctrl** key, and has a small picture of a context menu and arrow cursor on it. But first you have to get to where you want to "click", since right-clicking is all about performing a function on a particular item. In Campground Master, use **Alt-G** to put the cursor, or selection focus, into the grid if it's not already there. (This generally shows up as one of the cells being dark blue.) Then use the 4 **arrow** keys on the keyboard to move the selection to the cell you want, and then press the **menu** key. The context menu will open, and then you can use the keyboard to select a menu item, either with the up/down arrow keys and **Enter**, or by using the underlined letter shortcut (eg. "T" for Transactions on a reservation context menu). You can also scroll the grid using the keyboard. After pressing **Alt-G**, use the **Page Up**, **Page Down**, **Home**, and **End** keys to quickly move a page at a time up, down, back, and forward. You can also use the arrow keys to scroll past the edge, and the grid will move so that the selection is always visible.

Searching on the tab views

You can search for a particular Site or Customer on any of the tab views by pressing **F9**, **Ctrl-S** or **Alt-S**. The main uses for this are to quickly scroll to a desired site on the Rack view, or to locate a site or customer on the other views.

When you press Alt-S, a small dialog will appear -- just type any portion of a site name, or the start of a customer's last name. Note that it will first search for a site name containing the characters you entered (it will search both the abbreviations and the "Site Name" fields). If no match is found, it will then look for a customer. So for instance if you're looking for a customer with "Smi" in the last name but you have a cabin named "Smiley's", it will match the cabin first.

Either way, if a match is found then the view will highlight the matched reservation (scrolling to it if necessary). In the case of the Rack view, a match of the site name will highlight the first visible cell of the site and a match of the customer will highlight the first cell of the reservation. (Note that it will only search reservations from today to the last date of the Rack that can be scrolled to, corresponding to the Maximum Future Days setting.) On any of the other views, when a match is found the entire line will be highlighted.

Data Entry Basics

Navigating in dialogs with the Tab key

You will spend a lot of time entering information in dialogs, such as customer information and reservation details. Therefore it's a good idea to learn the fastest way to get around in them. Generally you will use the **Tab** key to jump from one field to another. This will move the text input cursor to the next logical entry field or check box in the dialog. Mastering the **Tab** key (and **Shift-Tab** to back up a field) and also the **Alt**-key shortcuts for the buttons will allow you to do nearly everything in a dialog from the keyboard, without moving your hand to the mouse. Note that the **Enter** key will also move to the next field in most cases, but this was implemented only as a convenience for users that are familiar with an Enter-based system. This is not the Windows standard way of moving between fields, so it's best to get used to using the **Tab** key.

Selecting from drop-down lists

Many of the fields in dialogs will use pick-lists (most of which are user-definable), in the form of a drop-down list. These will have small down-arrow buttons on the right-hand side of the entry field. Initially you can use the mouse to click the down-arrow button to open the list, and then click on the desired option. Alternatively, you can use **Alt-down-arrow** to open the list with the keyboard. Whether it is opened first or not, you can use the **up** and **down** arrow keys to change the selected item.

Once you are familiar with the contents of the list, you can also select items quickly using the first letter of the selection. For instance, typing "**F**" in the Rig Type field will typically select Fifth Wheel automatically. In cases where the first letter is used by more than one selection, just press the letter repeatedly to change the selections. For instance, "**T**" may take you to the Tent selection first, and pressing "**T**" again will go to Travel Trailer. (Since "TT" is often an abbreviation for Travel Trailer, this just happens to make sense!)

Checking boxes with the keyboard

When a check box field is selected on a dialog (indicated by a dotted line around it), you can check or uncheck the box by pressing the **spacebar** on the keyboard.

Working with Dates

Another common dialog entry field is a date, which normally uses a "date-picker" control. There are several ways to enter a date. One way is with the mouse -- click the down-arrow on the right side of the entry field, and a calendar will open up. Just click on the date you want, using the arrow buttons to change the month as needed. For moving a large number of months, you can click on the month at the top of the calendar to produce a drop-down list of months to select from. You can even click on the year and it will show up/down buttons to quickly change years.

However, the keyboard can be used effectively if you already know the date you want to use without referring to a calendar. When entering a date field, the month will usually be highlighted at first. Just start typing the date as month/day/year, using slashes just as you would write it. The date will be entered as you would expect. You don't even have to enter the whole year -- for instance, type "**5/3/1**" for May 3rd, 2001. If all you need to change is the day, it's even simpler. To skip the month, start typing with the slash ("/"), then type the day. For instance, to change 11/5/2001 to 11/9/2001, just type "**/9**", then you can **Tab** to the next field as needed. There are other ways also -- you can use the **up** and **down** arrows to change the month, day or year (whichever is highlighted), and the **right** and **left** arrows can be used to move the highlight back and forth between the month, day, and year.

Check-Dates

Some date fields, such as the Paid-Through date, also contain a check box. This is a combination field which effectively allows you to select "None" as a date. When the box is unchecked in this case, it means there is no Paid-Through date (they have not paid). The date will be "grayed out" (lighter color) to indicate that it is not actually used. When the box is checked, the date is used just like any other date. Note that selecting a date with the mouse will automatically check the box, allowing you to save a step. If using the keyboard, you will need to check the box first (the **spacebar** can be used to do this from the keyboard), then you can edit the date by pressing the **right-arrow** key to get to the date portion of the field.

Copying and Pasting

The Windows operating system supports copying text from one place to another, to save you from retyping things over and over. The Windows "clipboard" is used for this -- you "copy" text onto the clipboard, and then you can "paste" it somewhere else. This can be useful if you accidentally type information in the wrong place and want to move it, and also when making multiple copies of the same text. There are two different key sequences that accomplish the same thing, so you can use whichever is more comfortable for you. Basically, it is a 4-step process:

1. Highlight the text you want to copy, using the mouse (click-drag) or the keyboard (shift-arrow).
2. Copy the text to the "clipboard", with either **Ctrl-Insert** or **Ctrl-C**.
3. Move to where you want to copy the text, either with the mouse or keyboard.
4. Paste the text from the clipboard with either **Shift-Insert** or **Ctrl-V**.

Note that the text will stay on the clipboard until something else is copied, so you can paste it to another dialog field, or paste it as many times as you like by repeating steps 3 and 4 above.

If you want to move the text instead of copy it, then you can use "cut" instead of "copy" in step 2 above. Use **Ctrl-X** or **Shift-Delete** to cut (or delete) the text. The text will also be copied to the clipboard so you can paste it. Be careful **not** to use **Ctrl-Delete**, since this will delete it permanently rather than put it on the clipboard. (This is one good reason to use **Ctrl-X** instead of **Shift-Delete**, to avoid confusion.)

3 Setting Up Your Campground Database

Overview

This section provides a "brief" overview of what is required to set up a Campground Master database for your campground. For the details, refer to the Maintenance section later in this manual. Even if someone else does the setup, it can be helpful to learn about the basics so that you understand the software better, and in case you want to make occasional changes. You can make most changes yourself, such as adding or changing rental sites, adding new operators, adding transaction categories, and more.

Database Basics

Note: This section on Database Basics and the next section on Database Organization get a bit wordy and technical. While it's all important information to know, if you're anxious to get started setting up your database then you could skip to the Setup Checklist. We do recommend that you come back here at some point for a better understanding of how the database works, though.

The Campground Master database is contained in a single file, which has all of the information specific to your park. This includes the database definitions, program options and settings, operators, sites, and pick-lists as well as all customers, reservations and transactions, and all other data tables.

The Database File Name and Location

The database file that's currently open is always shown at the top, in the caption bar -- like "Database: My Park". When you first run Campground Master, the database name will either be "Demo" (if you loaded the sample database) or "<UNTITLED>". If it's <UNTITLED>, that means the database has not yet been named and saved to disk.

The database file may be given any name you like (typically you would use the name of your park), and it will have a file extension of ".PRK" (which you may not always see, depending on your Windows settings). Before setting it up for the first time, you should create a new database using the New Database function in the Maintenance menu. That will put the database in the default location automatically so you usually don't need to know the details.

For reference, the location should be as follows:

In Windows XP, the default location is the "Shared Documents" folder, which is usually shown as:

C:\Documents and Settings\All Users\Documents\Campground Master

In Windows Vista, 7, 8, 10 or later the default location is the "Public Documents" folder, which is usually shown as:

C:\Users\Public\Documents\Campground Master

In older versions of Windows and versions of Campground Master prior to 4.2, the database file was typically placed in the same folder on your hard drive as the program itself, for instance "C:\Program Files\Campground Master\". However this does not work for Windows XP and later so it was changed after version 4.2 if Windows XP and later are detected.

The database could be placed somewhere else if you prefer (see the guidelines below), but we don't recommend this except for advanced users, and not without a very good reason. This almost always results in problems down the road. In particular, do not put it on the Desktop or in My Documents, and do not try to put it directly in a cloud-sharing location like a "Dropbox" folder, or any place where you might want to access it from another computer (see Networking Note below).

If you prefer to choose a database location manually, keep in mind that Campground Master also places a number of other files in the same folder -- log files, automatic backups, etc., so the database file will not be the only file in that location. For Windows XP, NT and 2000 users, also keep in mind that it must be in a location where all Windows users (all Windows XP user accounts, for instance) have full access to write and delete files. If you have any non-administrator users set up in XP, this usually means setting up a special "shared" folder with full access privileges for all users, or using the "Shared Documents" folder.

Important: If you save the database to a different location using File / Save a Copy As, Campground Master then needs to be set up with that as the default database. Use File / Open to open the desired database (e.g. the one you just saved), and then go to Maintenance / Program Options / Database to change the auto-open database to the current one.

Networking Note: The database should **NEVER** be accessed through the network by another computer. Every computer running Campground Master should store the database on its own hard drive (see more details in the Networking Functions chapter). This is not just for reasons of speed (although that would be a factor) -- networking does not operate by sharing files, so if you're trying to set it up as a file sharing system then it's not going to work properly. Even if you're trying to locate the database on a server so it gets backed up automatically, this is not recommended. Instead you should have the server grab the file from one of the workstations when needed, or else have the server actually running Campground Master as the master workstation.

Multiple databases: If you have the need to create or access more than one separate database on a single computer, see the section in Maintenance -- "[Multiple Databases on One Computer](#)".

Manual Backups

It's **very important** to back up your database on a regular basis, in case of disaster or computer malfunction. The software has a built-in backup feature, for ease of storing a copy of the database on an external disk or memory stick. We recommend doing a **daily** backup, using a different disk or memory stick for each day of the week. The program will remind you to make a backup before closing the program if you haven't done so in 3 days, and will continue to remind you until you do so (this setting can be changed to remind you more often or less often if you prefer.)

Using day-labeled disks or sticks is a good idea. This way you have 7 different backup copies, and couldn't lose more than a day or two of work unless you have multiple failures. (Don't hesitate to make a backup more often, particularly early in the process of setting up the database in case you want to go back to a previous version and start over.)

In addition, we recommend at least a **weekly** off-site backup. Rotate at least 4 different disks and make a new backup every Friday night, for instance. Take the backup to another location -- at least in another building. This will help protect your data in case of a fire, theft, or other disaster. In addition to the security of backups, this will give you about 1 month of "oops" protection -- if you realize at some later time that a major database change was made by mistake, you could go back to retrieve the data up to a month old.

See the Maintenance section for more details on making backups and restoring them.

Automatic Backups

The program will automatically make a backup at the start of each day and place it in the same folder location as the database file. The automatic backups include the date in the filename, and are kept for 32 days (older ones are automatically deleted). However, since these backups are still vulnerable to computer malfunction (hard disk failures, viruses, etc), **this is not a substitute for making backups to an external device!** This is only an extra safeguard to make sure you have some form of backup.

Campground Master.ini File

There are a few settings that aren't part of the database because they're specific to each computer. These are stored on the computer so they are used each time without the need to reset them, but are not part of the database file itself. They're stored in a "Configuration settings" file, named **Campground Master.ini**, which is placed in your Windows directory in older versions of Windows (and versions of Campground Master prior to 4.2). In Windows XP it will be placed in the "Shared Documents" folder, and in Windows Vista it will be placed in the "Public Documents" folder (in both cases it will be in a "Campground Master" sub-folder, and this is also where your database should be). Note that if you started with an older version of Campground Master, it may exist in two locations -- if you're running Windows XP or Vista, be sure to check the Shared or Public Documents folder first and use that one.

The settings stored here include the Printer Setup settings, Network Settings, the last window sizes used (for some resizable dialogs), and the path to the last database opened.

It's a good idea to keep a backup of this file for convenience, however this will need to be done manually (just copy the file to a backup disk), since it's not part of the database backup function. If you're changing to a different computer, do **not** copy this file to the other computer, since the settings may not apply to that computer and can cause errors.

Other Files

There are some other files for which you may want to keep a separate backup. These files aren't changed by the program, so they aren't included in the regular database backups.

- **Map image files** -- If you use maps, you'll want to have a safe backup of the image files (*.bmp), which are in the same folder as the database.
- **Web templates** -- If you use the Export to Web function, keep a backup of the web template files (*.htt). These are in a location specified by the user (but most likely in the same location as the database).
- **Bitmap image files for Forms** -- If you've included images on user-defined Forms, these files are also in the same folder as the database.

Database Organization

A little background will help you understand how reservations and other database elements interact. Some of this may be pretty technical, and it certainly isn't required knowledge to operate the program. But if you prefer to know more about *why* it works the way it does, then this section will help.

The Campground Master database is a *relational* database. This means that it consists of multiple *tables*, which can be related to each other through *relational links*. There are four main tables in the database -- Sites, Customers, Reservations, and Transactions. (Parks and Operators are also tables, as well as all of the Pick Lists, but they're not important for this discussion.) Each table is a collection of *records*, where each record represents one item (a customer, a site, etc.), and each record is a collection of *fields*, where each field is a bit of information (a customer's last name, phone number, zip code, etc.).

In most cases, you will work with the records of a table individually -- for example, when using the Reservation Details dialog, you can only see or change fields in one reservation record at a time. Of course when viewing reports, you are looking at multiple records. Where there is linking going on, it will be transparent to you. But understanding what links do will help you make sense out of some things, like why the Notes column on the Arrivals View doesn't show the notes you just added to the customer's record (because the customer notes are separate from the reservation notes).

This is an example of how the main data tables are related, or linked, to each other:

- Each Reservation record is linked to one Site record and one Customer record.

- In addition, a Reservation can have a list of other "linked" Reservations linked to it.
- Each Transaction links to the Reservation and/or Customer it applies to, if any. The Reservation and Customer also link back to the Transaction (so one reservation can have links to many transactions).

As you can see, the Reservation table is the primary table from which everything related to it can be reached. When a report shows the customer name and phone number for a reservation, that information is actually coming out of the Customer table, through the customer link in the reservation. Thus if the information is changed for the customer, it is automatically changed for every reservation that the customer has ever made.

The advantages of relational databases are many, but primarily it helps keep data consistent and allows the database to be much smaller since unique information is only stored once.

Setup Checklist

Here is a quick checklist of things that you should do to get the software set up, including some option settings that you may want to change. Refer to the appropriate sections for more details.

Database Setup:

- Create your New Database file, so you have a "clean slate" to work with.
- Park information and Authorization Code -- this must be done first to enable the software!
- Operators and Access Levels -- define operator logins and passwords as needed.
- Data table fields -- decide which fields are important to you, and disable any that you won't use:
 - Park Fields -- Usually the only ones needing changed are the fields for electric meters, etc, covered later.
 - Site Fields -- These depend on many factors (which optional functionality you use). Much of this is covered elsewhere. For now just look at the Attribute fields as explained in the Data field definitions documentation.
 - Rate Fields -- We don't recommend disabling any of the fields here.
 - Reservation Fields -- As with Sites, just look at the Attribute (preference) fields for now. Other fields should be left alone unless mentioned for some other function.
 - Customer Fields -- Here's where you can disable a lot of things you don't need. But don't get carried away at first. You can disable things later if you decide they're not being used.
 - Transaction Fields -- Except for the Shift field, covered in Shift Functionality below, you should not be making changes here.
 - ... the rest of the data tables should be left alone unless instructed elsewhere.
- Pick lists:
 - Site Classes and Types. Keep in mind that these affect many things, especially rates selections.
 - Pad Types and Site facing (if used)
 - Transaction Categories -- very important for financial reporting. Don't forget categories for Sales Tax, etc.
 - Note:** If you plan to export transactions to QuickBooks, you may want to base these on your QuickBooks accounts, to make the mapping easy.
 - Payment Methods -- enable the types that apply to you

Discounts list, Rig types, How-heard, etc. -- add, remove, or rename the default entries as needed.
Reservation Types -- You can use your own names for the different types of reservations, or define more types as needed.

- Shift Functionality -- Enable shift tracking functionality if you need it.
- Schedule Functionality -- If you need to handle hourly reservations, for instance.
- Site 'Dirty' Functionality -- If you need this for tracking dirty rooms for housekeeping
- Sites -- set up each campsite. You might set up just a few sites for now to help in testing other settings, and continue later.
- Maps -- if you want an interactive map view of your park, you can set it up after all of your sites are set up.
- Taxes -- set up the applicable tax rates (make sure you have a unique Transaction Category for each one first).
- Rates -- set up rates for each site type or class, with specific dates, applicable discounts, etc.
- Metered electric, gas and/or water support -- see that section for step by step details.
- Printing Options -- Reservation Receipt default format, number of copies, etc.
- Printed notices & text -- Customize the "notice text" and other options for receipts, etc.
- Printer Setup -- which printer(s) to use for each type of printing.
- Color Keys -- If you don't like the colors we chose for reservation status, you can set your own
- SMTP setup for sending E-mail, and E-mail Confirmation options
- Other Program Options -- lots more options for the finer details of operation

Advanced / Optional Functionality

- Import customer and/or reservation data from another source, if available.
- Network setup -- **It's important that you read this if you plan to use Campground Master on multiple computers!**
- Reservation Restrictions -- to define custom restrictions and reminders
- Deposit definitions -- to define automatic deposit amount calculations
- Point of Sale setup, if applicable
- Credit Card Processing -- if you want to process cards directly through Campground Master
- Online Reservations setup, if applicable
- Advanced Customizations -- this really gets into programming, but allows you to customize many parts of the system.

Creating your Database

Before setting up your park information, you need to create a new database file that will be used to hold everything. If you've used any other computer program that works with files, like Microsoft Word, Excel, etc., then you're familiar with this concept. One difference is that since you would most likely never use more than one database with Campground Master and only have to do this once, there isn't a simple "New document" function under the File menu.

Important: If you have multiple "Users" for logging into Windows, make sure you're logged in as an Administrator before starting. Otherwise it can't create the necessary files.

When you start the program for the first time, and assuming you're not purposely running the "demo", then you will be told that "**No database is defined**", and it will ask if you want to load the sample database. You should answer "**No**" to this, so it opens with a blank "<Untitled>" database.

The next step is to create a database file. Go to [Maintenance / New Database \(create a new database file\)](#). This will show a warning prompt and it sounds scary, and in a way it's meant to be scary because you should only do it once, but really all it does is create a new database file with a name that you give it. Answer "**Yes**" to the prompt, and it will ask you for a database name. We suggest entering the name of your park, or perhaps a short version if it's a lengthy name. There's no reason to make it more than a couple words long.

Click OK after entering the name, and the database will be created in the proper location, and you're ready to start setting it up. The new database will be the default database and will automatically open the next time you start Campground Master, so you should never have to worry about trying to find it.

Important: When you create a new database, it doesn't ask you to log in. The default Administrator operator is created and you are automatically logged in. You should do the Operator Setup soon to establish your own logins, but if you don't do that before closing the program then you will be asked to log in the next time you start it. You will need to use the default login, described in the earlier section on Logging In and Out.

Park Information and Authorization Code

The Park information is not seen very often in the software, but it's very important. It primarily consists of the campground's name, address and other contact information. This is used on the printed receipts. There are also three Notes fields for the park, which can be used to add "Additional Notes" to the printed Ticket Form receipts.

The other important thing about the park setup is the Authorization Code. This code is required to access full functionality of the software (in fact you won't be able to define your sites without one), and is keyed off of the other park information. When you purchase a license for Campground Master you will need to provide your park name and address information, which is used to generate a Key Code. Cottonwood Software will then issue you an Authorization Code, which you must enter to unlock the software. Thus, if the park changes its name or address, a new authorization code will be needed (but you will not be required to purchase a new license unless this is an *additional* installation).

If you have already purchased the software, then the procedure for entering the authorization code will be either in the pocket in the front of the printed manual or in an E-mail confirmation message (depending on the method of purchase). See Park Setup in the Maintenance section for more details.

Operators and Access Levels

Campground Master requires a log-in for security purposes, and for tracking the originator of reservations and transactions. The current operator's name, as well as the time and date, are recorded for every financial transaction, reservation creation, cancellation, check-in and check-out. It's recommended that every person using the software have a different operator name, and be assigned an appropriate security level. In addition, one or more **Administrator** operators should be set up, which may be additional accounts for someone. For instance, the campground manager may have a **Manager** level log-in and also an **Administrator** log-in. This would prevent accidental administrative changes when logged in as a manager, but allow administrator access when needed.

Operator information can only be viewed or changed by an administrator. If no operators have been set up yet, use the default login -- Operator Name "Administrator" and Password "Password". You should change these to something that only you know, but don't forget the administrator login or else you won't be able to get back in to the maintenance functions!

To add or change operators, go to Maintenance / Park Setup / Operators. See Operator Setup in the *Maintenance* section for more information.

PCI Compliance note: Refer to the PCI/PA-DSS Compliance Guide (see the *Introduction* chapter) for important details about proper security procedures if credit card information is stored in Campground Master.

Each program function requires a certain access level for it to be enabled. The minimum access level required for many of these the functions can be configured as needed. Most Maintenance functions are fixed at the Administrator level, but many others are configurable so you can decide what level can perform the function. Typically this will be either Reservation, Manager or Administrator, depending on how restrictive you need to keep it.

See Access Levels Setup in the *Maintenance* section for more information on setting up access levels.

Pick-Lists

There are several "pick lists" used in the software for fields that have a limited number of options rather than free-form text entry. These are usually presented as a drop-down list in dialogs. This "limitation" is actually a great advantage, however -- it speeds data entry, better organizes the database (and actually makes it smaller and faster), and allows for easy filtering of reports. For instance, you can generate financial reports for a specific site type or class (RV lot, cabin, etc.), certain payment methods (credit cards, cash, Visa, etc.), or any transaction category (daily rate, monthly rate, gift shop, laundry expenses, etc.).

Since each of the pick lists is user-definable, it's not really a limitation at all. The software comes pre-defined with common selections in the pick lists, but you can edit, add, or delete selections as needed (and even add more items later), and define the order in which they appear in the lists. Careful selection of list items is recommended (particularly the Site Types, Site Classes and Transaction Categories), because they affect how you will use the software, and because once the lists are in use, you cannot delete items without causing gaps in the useful data.

The Reservation Types list is a special-purpose list, since each type must also be designated as a particular "base type" to determine how it's used by the program. Renaming and adding multiple reservation types can be useful for reporting and statistical purposes.

See Pick-Lists in the *Maintenance* section for more information.

Customizing Data Table Fields

Each of the data tables in the database (Sites, Customers, Reservations, Transactions, etc.) are made up of a list of Fields. The fields included in the tables are user-definable to a certain extent, adding to the flexibility of the software. For instance, if you don't have a need to ever know about the Estimated Arrival Time for a reservation, you can disable that field and it will be removed from the database. Besides saving space, the disabled field will be removed from the dialogs resulting in a cleaner view and slightly faster data entry.

Many of the fields are "Fixed", which means that they cannot be disabled. These fields are crucial to the operation of the software, such as the reservation start date. Others are optional and can be enabled or disabled as needed, as in the example above.

There is a special category of fields called "Attributes", which appear in the Reservation table and the Sites table. There are dozens of attributes, like "Has 50 Amp", "Waterfront", and "Pad Type". These are used primarily for selecting Site Preferences for a reservation. Once the preferences have been selected, the list of sites available will show only sites that have matching attributes. Thus you can easily match a customer to a site that will meet his or her needs the best. Many of the pre-defined attributes won't apply to your particular campground, so you can disable these or rename them to something more useful. For instance, if none of your sites are waterfront but you have some desirable cabins that are cliff-side, just change the text from "waterfront" to "cliff-side".

Many of the customer and reservation data fields can be renamed and used for different purposes. For instance, you can change "# Pets" to "# Meals", or "Phone 2" to "Cell Phone". The labels on dialogs will usually be the "Short label" you enter, and column headings will be the "Report heading" you enter.

Some of the fields enable or disable not only the data entry but a lot of associated functionality as well. For instance, if you enable the Site "Dirty" field, then you also enable the associated functions and display options that go with it -- menu functions to mark it dirty or clean, columns to show it on the Rack and other reports, options to automatically set the flag and warn if it's dirty on check-in, etc. Enabling the Shift fields adds functionality for shift changing and reporting (more on that later). Enabling the Reservation "Label" field allows you to change what shows on the Rack for a reservation, and gives you another way to search for reservations.

Note that once the database is in use, you can still enable and disable fields or change their text. However, be aware that any data in newly-disabled fields will be lost even if you re-enable the field later (assuming the database is saved to disk and reloaded before re-enabling it).

See Data Field Definitions in the *Maintenance* section for more information.

Shifts Functionality

If you need to enable the functionality for Shift reporting (for instance if you have 2 or 3 shifts per day and need reporting based on shifts, rather than days), then you need to enable two specific fields in Maintenance / Data Field Definitions (see Define Data Fields in the *Maintenance* section for more information.)

- In the Parks field definitions, enable the **Park_Shift** field.
- In the Transactions field definitions, enable the **Tran_Shift** field.

With these enabled, the Shift Change and Shift Report functions will be available on the Maintenance menu, and the Shift filtering and summarizing options will be present in the Transaction tab view filter and options.

After the shift fields are enabled, you may need to exit and restart Campground Master for the Shift functions to appear on the Maintenance menu. Then you should go to Shift Change and enter the shift number you want to start with (for instance, 1000).

When shifts are enabled, all transactions are tagged with a shift number. In addition to restricting transaction changes after the shift is closed out, this allows shift reports to be done for any shift in history, and helps track down the source of operator errors.

Note: You may want to enable the Shift functionality even if you only have a single shift per day, just so you can use the Shift Report. This report provides a handy summary of the transactions of the shift

Schedule Functionality

Schedules are used for intra-day reservations, for instance hourly rentals, tours, etc. There are several steps required to set up Campground Master to handle reservation "schedules", which are detailed in the Maintenance Section. If you don't need to track intra-day reservations, then you can ignore Schedules.

Site 'Dirty' Functionality

The Site field "Site_Dirty" is disabled by default because it's primarily useful for motels and inns, so most parks don't need the functionality. When it is enabled (through Data Field Definitions), quite a few extra menu items, report options, etc. are added. If you think this would be useful for you, see the Maintenance section for details.

Sites

The Sites table is the main part of the database setup for your campground. Here you define all of the rental "sites". A site can be a campsite, an RV lot, a cabin, a boat dock, a pavilion, a bicycle, or anything else you need to rent out by the day. The sites table is what shows up in the Rack View (usually the Y-axis of the Rack grid), as well as playing a large part in how other views are used. Every aspect of the sites is user-definable, including the name (actually 3 different designations), the type, the dates available for rental, and dozens of attributes that can be used to quickly determine whether a site fits a customer's needs.

There are some Pick Lists that should be defined before setting up the sites: the Site Classes, Site Types, Site Facing and Pad Types. (These should have been defined in the earlier steps.) These are helpful in categorizing the sites and simplifying the selection process when making a reservation, as well as filtering statistics when generating reports. Once these pick lists are set up, you can define the details of each site. The main pick lists are the Site Types and Site Classes, as these lists appear on many views and dialogs and makes it easy for you to limit the current view to just Full Hookup sites or Tent sites, for instance. The Pad Types and Site Facing lists are helpful when selecting site preferences for a reservation to narrow the search for a site.

See Sites Setup in the *Maintenance* section for more details.

Maps

You may want to have a map view of your park, which will show the occupied status of each site and can also be used interactively like the Rack view (e.g. right-click menu functions, double-click to make a new reservation on an open site, check availability, etc.). When a map is set up, a new "Map" tab will appear next to the Rack tab. Most of its functionality will be the same as the Rack.

This is an optional function, and of course it requires a graphic image to be used for the map. In addition, a status indicator must be set up for each site on the map. Multiple maps can be used if the park is too large to fit on one map view. If you have a map of your park, it could be scanned in and used -- you could even draw one on paper and scan it in, or even just use a blank image and lay out the site indicators accordingly.

See Maps Setup in the *Maintenance* section for more details.

Taxes

You will want to set up any applicable tax rates for ease of transaction entry, rates definitions, and reporting. First make sure you have a Transaction Category for each one (Maintenance / Pick Lists / Transaction Categories), then set up the Taxes.

Note that each different tax category will be reported separately and printed separately on receipts. Also note that when defining Rates and entering charges, the tax rates can be used in any combination so there's no need to define "combination" rates.

See Taxes Setup in the *Maintenance* section for more details.

Rates

You will want to set up your applicable rental rates for each site type/class, plus add-on charges, meter rates if needed, and perhaps other rates for convenience. This is one of the more involved processes, and is completely optional (you could enter the amount of each transaction manually), but is well worth it.

Since rate definitions can be categorized by Reservation Type, Site Type, Site Class, and Discount, the design of those pick lists is very important. When selecting a rate to use for a reservation, the list of rates displayed will be filtered by the reservation type, site selected, discount used, and the reservation dates. Therefore you can minimize the selections shown by planning your rates carefully.

In particular, You should have **at least** one Site Type for each different *basic* rental rate. This does not need to include *add-ons* like 50A electric, phone, etc. Alternatively, you can make Site Types more specific so that selection by customer preferences is easier, and use Site Classes to differentiate the rates. In this case, you would define one Site Class for each basic rate you have.

Discounts work similarly, but in most cases these will not be as complicated as site types/classes, since there is usually only one kind of discount rate for each discount club.

See Rates Setup in the *Maintenance* section for more details.

Deposit and A/R Balances

Campground Master keeps a running balance of unused deposits (advance payments toward reservations) and accounts receivable (charges not yet paid). If your account methods include tracking either or both of these, Campground Master can keep track of them for you, or at least help verify that things are in balance if you track these separately.

Deposit and Accounts Receivable tracking and adjustments are discussed further in the *Working with Transactions* section, and making adjustments is discussed in the *Maintenance Functions* section. What you need to know when setting up your database is that you can enter a "starting balance" for either of these, so that the running totals match your previous figures. This is entered as an adjustment, and should be done before entering live transactions so it's recorded in front of other transactions. Deposit and A/R Balance reports can be found in the Transactions tab view report (Summary Transaction Reports).

Metered Electric, Gas and Water Support

There are 4 things that need to be done for properly supporting metered electric, gas or water. Here's a brief checklist -- there is a more detailed walk-through section in the Maintenance chapter.

1. Enable the appropriate fields in the Data Field Definitions for Sites (or disable them if no metered support is needed).
2. Set the meter wrap-around numbers, depending on the number of digits each type of meter has, in Park Setup / Parks.
3. Enter the current (or last) meter reading for each site that has a meter, through Park Setup / Sites.
4. Define one or more Electric/Gas/Water Meter Rates for the meter charges (Park Setup / Rates).

Once the setup is done, you can simply enter the new readings (either one at a time or as a batch), and it will calculate the charges and update the reading for next time. See the Maintenance chapter for full details.

File - Printing Options

There are a number of settings that affect the way reports, receipts, and other things are printed. These should primarily be set up by an administrator and not changed arbitrarily. This function appears here as a convenience (to be near other printer settings and functions), but they are also found under the Maintenance menu. See *Printing Options* in the *Maintenance Functions* section for details.

File - Printer Setup

There are different Printer Setup configuration functions for each kind of printing that the software does. You can customize the orientation, paper size, and paper source settings for each printing task, and even specify a different printer for each task. All of these settings are remembered so that they only need to be set once.

Note that any printer settings that use the Windows "default printer" will automatically change if the Windows default printer is changed (for instance if you install a new printer). The settings should be re-checked in any case, since the new printer may not support the same paper size or source, resulting in an improper setting.

Campground Master can support any printer that can be driven by Windows. Ink jet printers are the most common type used, and will best allow the graphics and color to be printed.

Manager access is required by default to change Printer Setup options.

Default (grid-type reports)

This setting is used for everything that isn't a special format. This includes the tab views and any report that prints in a grid-type format. In some cases you will want to set this to Landscape orientation so that more columns fit on the page.

Map view

This setting is used only for the Map tab view.

Receipt formats (various)

You can set up different printer settings for each specific receipt format -- Ticket Form, Full-page Invoice, Confirmation Letter, etc. For instance, you may want to print receipts on small paper and confirmation letters on normal paper. To avoid changing paper, you can connect a different printer for each printing task (this would even allow printing of invoices and window tags at the same time, for instance).

Receipt Printer (3" paper)

The Receipt Printer settings are specifically for retail-type receipt printers which typically use 3" roll paper. Any receipt printer that has a serial or parallel interface, or has a Windows printer driver, should work with Campground Master.

Note: This printer setting is also used for credit the card slip receipt formats, for instance if you have credit card processing handled by Campground Master.

For details on setting up a receipt printer, see one of these sections in the Maintenance chapter, depending on how the printer is connected to the computer:

For USB printers or any printer using a Windows driver: Receipt Printer USB/Driver Settings

For old style printers directly connected to a parallel or serial port: Receipt Printer Direct to Port Settings

Note that you don't actually have to use a special receipt printer to use the 3" receipt formats. For instance you can set it to use a full-size printer and select a paper size like #10 envelopes or index cards, to print narrow receipts on specially sized paper.

Purchase Orders

This only appears if the P.O.S. option is enabled. It specifies the setup for Purchase Orders, in case they need to be on a particular printer.

Envelopes and Mailing Labels

The most likely change needed is to set the Envelopes to use Landscape orientation and the proper paper size (e.g. Envelope - #10). Otherwise you may not see anything print on the envelope, since the default is Portrait orientation.

Mailing labels are assumed to be the typical 30-per-page mailing labels. The default printer settings will usually work, but some tweaking of the offsets in [File / Printing Options](#) may be needed.

Custom printers

These are extra printer selections that can be used for custom Forms, in case you need to set up a printer that's not used for anything else. (Otherwise one of the other selections above could be used for the custom form.)

Refresh printer selections

This is a special function that simply forces Campground Master to reload the printer information from Windows (same as if you closed and restarted Campground Master). No settings are changed. This can be useful for instance if the default printer has changed, assuming you have not created a special setup with one of the options above. Try this first if you're getting printing errors and it seems to show the correct printer in Printer Setup, or if it's locking up if you try to go to one of the Printer Setup configurations.

Reset ALL printer configurations to use the Windows default printer

This is a special function that will completely reset all of the Printer Setup configurations you might have created above (deletes them from the INI file), resetting them so it will use the Windows default printer settings unless manually configured. This may be required if a printer driver has been re-installed or the printer changed to a different port but still uses the same name. This is a drastic measure and should probably only be done if directed by a support technician. Administrator access is required by default for this function.

File - Print in Black & White

This setting on the File menu will make any grid-type reports print in a basic black & white format with no colors and no shading of headers. This will save ink, print faster and make printouts look better on non-color printers. This option also appears on the File / Printing Options dialog, but was also placed here for convenience. The option may be changed here by operators without Manager access, whereas the Printing Options dialog can only be accessed by managers.

File - Fit to Page Horizontally

This setting on the File menu will ensure that any grid-type reports don't require multiple pages in width (they may still require multiple pages in length). The downside is that reports may print in a different size text, sometimes much too small (whatever is required to make it fit). This option also appears on the File / Printing Options dialog, but was also placed on the File menu for convenience. The option may be changed here by operators without Manager access, whereas the Printing Options dialog can only be accessed by managers.

By default, if the standard text size is small enough to fit the report on the page horizontally then the standard size is used. In other words, the text might get shrunk but it won't be stretched to fill the page. However, there is an option to stretch the text to fit the entire width, in case you want extra-large printing. This option is under File / Printing Options.

View - Toolbar

You'll see this option in the View main menu, and it controls whether the main toolbar (the large picture icons below the menu) are displayed. While most users will like the toolbar for quick access to the main functions, expert users that know the keyboard shortcuts may prefer hiding the toolbar so that more space is available for the tab views. Manager access is required to change this setting.

View - Status Bar

This option is in the View main menu. It controls whether the status bar is visible, which will appear at the very bottom of the main window. The status bar simply shows short help-hints for menu items (whatever the mouse cursor is hovering over), some progress messages (for instance, "saving database"), and the state of keys like **Caps Lock** and **Num Lock**. Its functionality is minimal, so most users prefer to leave it turned off in order to gain an extra line on the tab views. Manager access is required to change this setting.

View - Color Keys

The Color Keys have a dual purpose -- they show you what the color coding means, and also allow you to change any of the colors. The color keys for Reservations and Maps can be accessed in the [View](#) menu, and are also available on all of the right-click context menus for quick access.

Reservation Color Key

The Reservation Color Key dialog shows a list of reservation status conditions, and each status condition will be shown in the current colors defined for it. The list is longer than the dialog allows, so you will need to scroll the list to see them all.

Changing colors

To change a color for a status (assuming you have sufficient operator access), [right-click](#) on the item in the list. You can change both the text color and the background color.

The standard Windows color dialog is used to change colors, where you can select one of the basic colors or define your own color. To define your own color, first click on one of the empty Custom Colors boxes. Then click on the approximate color in the "rainbow box", and adjust the brightness slider control (on the right side) until the color is just right. The selected color will be updated dynamically in the box below the rainbow (Color / Solid).

When finished changing all of the colors to your liking, click the [Done](#) button on the Color Key. If you click Cancel, **all** of the color changes will be canceled.

Maps Color Key

This is used on the Maps tab view, if maps are enabled. The operation is the same as described above for reservation colors, but the colors apply to site status and other map indicators.

Customizing Color Keys (Advanced)

If desired, you can define custom colors for reservations and/or map colors. This is done through Color Schemes definitions and by selecting a Global Default Color Scheme (see the Maintenance section).

If a custom Global Color Scheme is defined, the key will show the colors for the rules defined in the custom color scheme at the top, followed by the normal default colors.

Note that if the color item is from a user-defined Color Scheme, the right-click menu will show "Edit Color Rule" instead of selections for editing the colors. Selecting this menu option will open the Edit Color Rule dialog where you can change anything about the rule, not just the colors. There will also be an [Edit Scheme](#) button on the dialog where you can edit the Color Scheme directly.

Web Vacancy Grid Color Key

This is used for the Export to Web Vacancy Grid function. This allows you to make the web vacancy grid colors correspond to the design of your web site. The operation is the same as described above for reservation colors, but the colors apply to web page colors instead of reservation status. Note that some of the color entries only apply to background colors.

Import Data From Other Sources

If you have your customer data (or even reservation data) in some other electronic form, it can probably be imported to Campground Master. This can help jump-start the process so that you don't have to start re-entering customers from scratch. However, we recommend entering at least several customers and reservations yourself as practice before going live -- you need to get familiar with the process. In fact, if you have the time or help to enter your entire customer database manually, it's not a bad idea to do so to make sure it's entered in the best format possible, and so that all possible fields are covered.

The Import function is fully covered in the *Import and Export Functions* section later in the manual.

Network Settings

If you have purchased the networking version of the software for use with multiple networked computers, then you need to install the software on each computer (workstation), and then enter the appropriate settings on each computer.

Important -- Networking Campground Master is different than most database networking. Do NOT attempt to share the database between computers!

See the [Maintenance / Network Functions / Network Setup](#) function, and the Network Functions section of the documentation for complete information.

View Product Authorizations

This [View](#) menu function simply shows a dialog with your current authorizations, according to the license you have purchased. There is nothing to edit here, so it's just for reference if you are asked for it when calling for support. The authorization key is entered through the Park Setup, covered elsewhere.

View - Minimize to the Taskbar Tray

This [View](#) menu function will hide the Campground Master window and show an icon in the small taskbar tray (usually in the lower right corner, with the clock and other system icons). A button will not be shown on the taskbar as it would with the normal "Minimize" function. This is primarily used for a network servers where you just need to run in the background but not use it as a workstation.

Other Program Options

There are a number of other settings that affect the overall operation of the program. Since these should be set up by an administrator and not changed arbitrarily, they are found under the Maintenance menu. We recommend that you go through each of the sections (or menu items & sub-menu items) in Maintenance to configure them as needed.

4 Dynamic Interactive Report Screens

Overview

The dynamic interactive report screens, or Tab Views, are the heart of the software and provide the information and functions commonly needed every day. They are "dynamic", meaning that they will automatically update every time a change is made to the database. You don't have to "refresh" these reports, since they're always up to date. They are "interactive", meaning that you can work with the data directly on the report -- just right-click on the data and you will be given several operations to choose from. The initial setup has a set of recommended Tab Views configured (one of each possible type), but their order, names, an content can all be changed through Maintenance / Advanced Customizations / Tab Views.

A Tab view consists of a grid for the report itself, plus a control area above the grid. The controls for each view are similar, with dates and drop-down boxes for filtering the report, plus buttons and other options specific to the report. Most tab views share very similar right-click menu functions, navigation commands, and other features as described below.

To view any of the Tab Views, simply click on its "tab" (the row of labels above the views, like tabs on file folders). The selected view will appear instantly. (There may be a slight delay the first time it's accessed, but it will be much faster thereafter.) The name of the selected view will be shown in bold text so you can easily see which one is active. You can also change tab views using the **Tab** key on the keyboard or the Shift-function keys (see the *Keyboard Shortcuts* section for details).

Each tab view has an access level which determines who can view or print it. These levels can be changed through the Tab Views function. Tab views that have a higher access level than the current operator will have their title shown in a light gray text, and clicking it will simply not have any effect.

Tab views will have scroll bars if the data is too large for the screen. To see the rest of the data, simply drag the "thumb button" in the scroll bar or click in the scroll bar in the direction you want to view. With the exception of the Rack, which uses uniform cell widths, the cells in the grids will auto-size to fit the text in them. Therefore each report will have varying widths depending on the length of names, phone numbers, notes, etc. for the items in the lists.

Tab views that display fields in columns may have a Totals row at the bottom. (This can be disabled in Program Options if desired). This will show the total number of reservations shown in the report, and will also show totals for any columns that are appropriate -- such as # of adults, extra vehicles, and balance due.

Tip: Occasionally you will see a cell that is dark blue -- this is simply the grid "cursor", indicating the selected cell, and results from clicking on the grid or pressing **Alt-G**, or from using the Search function. This selection will be moved if you click on another cell, and will disappear if you right-click on a cell or change to another view, or press the **ESC** key (if focus is not on the grid, you may need to click on the grid first). In any case, the dark blue highlight is harmless and not part of the report (it will not show on a printed report).

Common Controls and Settings

Overview

The control area above the tab-view reports allows you to filter the information to be displayed. Some of these are common to most reports and are described here. Unique controls are described with each of the reports. Since these are dynamic reports, the view will change immediately when you adjust these controls.

Date Selections

Most important is the date or date range selection -- each view has a start (From) date and most have an end (To) date. In addition to the common date-picker controls, there will be left and right buttons (arrows, "<" and

">") on each side of the dates *if your screen size is 800x600 or greater* (there isn't enough room for them on 640x480 screens). These buttons will increase or decrease the date by one day, making it easy to step through dates one click at a time. Note that when changing one date, if the other date causes a backward date range, it will automatically be changed to the same date. Thus if you increment the From date on the Arrivals tab and the To date is already the same, then the To date will automatically be adjusted to match the new From date. This makes it easy to step through single dates without changing both date-picker controls.

In addition, many reports have buttons for Today, Week, Month and Year. This makes it easy to see these common ranges with a single click. Note that the Departures and On Site views have Yes/Today instead of Today, which is an abbreviation for "Yesterday and Today", so that you can easily see these two days at once. (It's useful to see yesterday's Departures and On Site because the reports are based on the reservation's Last Night, so "yesterday's" customer may not actually check out until today.) However you can also have Yesterday and/or Today as options, if you prefer limiting the views to a single day (see the Options).

Site Type, Class and Park Selection

The Site Types drop-down list limits the reservations or sites in the report to a specific site type, site class or park (if you have more than one Park record defined). The default is All Site Types, but you can select a single Site Type to view, or in some cases you can view all Assigned Sites (i.e. reservations for which a site has been assigned) or all Unassigned sites.

The drop-down list actually has a few different parts to it:

General selections -- The first part of the list will have the general selections like All Site Types, Assigned Sites and Unassigned Sites (as appropriate). These are a simple way to reset the selection to show all sites or all assigned/unassigned sites.

Site Types -- Each site type defined will be listed, in the order defined in the Site Types Pick List. Selecting one of these will limit the report to only sites of that type

Site Classes -- After a "-- Classes:" divider, the site classes will be listed as defined in the Site Class Pick List. As with site types, selecting one of these will limit the report to that site class. Classes are generally defined as being more general than since types, and thus one site class could include sites of several types.

Parks -- If your database is set up for more than one Park, there will be an additional section for selecting a single park. This will show all sites in that park, regardless of type or class.

Filters -- In addition to selecting a single type or class (or park), you can define an Advanced filter. You can also set up a Default filter, which is the same as an Advanced filter but will be used as the default selection for this report every time it is "reset" (with the Reset or Today button, for instance). Both of these functions use the Site Filtering Dialog.

Important -- If a Default filter is defined for the Rack view, this will also be used for the default when making a New Reservation.

Resetting the Default filter -- If a Default filter is set, it will jump back to that filter any time you restart the program or click a "Reset/Today" button. If you need to clear the default filter so it reverts to "All Site Types" normally, then first select the Default filter from the drop-down list. That will open the Site Filtering dialog -- click the "Reset Filtering" button to clear the default filter, and click OK. Now when you click a "Reset/Today" button it will go back to "All Site Types".

Site Filtering Dialog

The Site Filter dialog is used in many reports to select specific filtering by individual site, site type, site class, or park. This allows you to filter the sites to be included by more than one condition at a time, for instance you can include 2 or more site types at once, or 2 or more classes, or sites of a specific type in a specific park.

The dialog will have 3 or 4 lists on it -- Sites, Site Types, Site Classes, and Parks (if you have multiple parks in the database). Each list is a multiple-selection list, so you can pick one or more from each list (use Ctrl-Click to select multiple entries). If a list has nothing selected, that's the same as selecting all of them (i.e. no filtering is done for that field). To start over and clear the list so no filtering is done, you can click the Reset Filtering button

Note that in some cases there will be a "(no site)" entry at the bottom of the lists, which allows you to select reservations that have no site assigned, or transactions that are not bound to a reservation, for instance. Some reports don't allow selecting unassigned sites (for instance the Occupancy Report), so this won't be an option when filtering for those reports.

Be careful about selecting items from more than one list at a time, since the filtering uses "AND" logic -- for instance if you select an "RV" site type and a "Boat" site class, then it would only show a site if it's an "RV" type and it's a "Boat" class. This which would probably result in an empty report. If you want to show RV's and Boats together, then select both criteria from the same list -- either type or class, as appropriate.

Text Filtering -- Click this button to set up a text search so it only include sites that have a data field matching certain text. See Text Filtering for details.

Text Filtering -- Find Text Dialog

The "Find Text" dialog is used when using the text-search function from a report or a tab view, and also when the Text Filtering option is selected from within the Site Filter, Reservation Filter, Transaction Filter, Inventory Filter, Purchase Order Filter, or Audit Trail Filter.

Text-Search function on Grids

The text search function can be used in nearly any report, list or setup function that has a "grid" to help locate text shown in the grid, or in many cases to "deep search" the data represented by the grid, e.g. search the reservations and/or customer data for all records shown in the grid even if that field isn't shown.

After initiated from the grid (see below), the first cell found with a match (starting from the cell that was currently selected/highlighted) will be highlighted, scrolling the grid to make it visible if necessary. Some reports will highlight the entire row, not just the single cell, if that's how the selections are normally shown on that report.

Once started, you can use the Find Next shortcut (see below) to jump to the next match without re-opening the dialog. The next matching grid cell will be highlighted. If the end of the grid is reached, then it will go back to the first match (if only one match is found, it will remain highlighted).

Note that if you're using the "Search All Record Data" option and the match is due to data in the record instead of what's actually shown on the grid, then using Find Next will jump to the first cell in the next row with a match, rather than the next cell on the same row. This keeps you from wasting time cycling through every column of the same matching record.

On Tab Views

When on a Tab View (with no pop-up dialogs open). you can start a text search by pressing **Ctrl-Shift-F**. (Ctrl-F is used for the Find-Reservation shortcut, so a Shift is needed for text search.) Note that you may need to click somewhere in the grid first to make it the active window before this works. The Find Text dialog will appear, where you can specify the search parameters and click the Find Next button to start the search. Depending on the size of the grid and the parameters selected, there may be a slight delay before it shows the first match.

Once you initiate a search, use **Ctrl-F3** to "Find Next" without re-opening the Find Text dialog. Note that the search criteria is remembered as long as the grid has not been reset due to some database change or system function that requires a complete refresh of all tabs.

On Report Dialogs

When you're on any other report (any pop-up dialog with a grid), then you can use **Ctrl-F** to start a search. You don't have to use the Shift key as with Tab Views, although that will work too. You may need to click in the grid first to make it active, if there's not already something selected/highlighted in the grid. The Find Text dialog will appear, where you can specify the search parameters and click Find Next. Depending on the size of the grid and the parameters selected, there may be a slight delay before it shows the first match.

Once you initiate a search, use **F3** to "Find Next" without re-opening the Find Text dialog. You don't need to use the Ctrl key as with tab views, although that will work too. Note that the search criteria is remembered as long as the dialog remains open. Once the dialog is closed it will reset the search even if you re-open the same report.

Text Filtering from within other filters

Anywhere you use some other filtering function that uses a dialog to select options, for instance the Reservation Filter, you will see a "Text Filtering" button. This allows you to add a text-matching requirement to the filter (so only records with the matching text will be included in the results, assuming they also meet the other filter requirements). By default, this will search all fields of the applicable record (e.g. all Reservation fields if it's a Reservation Filter). Optionally you can search all related records (for instance to include the Customer records, etc. for each Reservation in the filter).

Find Text dialog (Search options)

Reset -- This button will clear the search parameters (blank the text and set other options back to default). You must still click Find Next button to complete the reset (Cancel will cancel the reset).

Find text -- Enter the text to look for.

Match Case -- Select this option if you want it to be case-sensitive, e.g. so "Tom" will not consider "tom" or "TOM" a match.

Include text in pop-up tips -- If this option is shown, and assuming the grid has pop-up tips on cells, then the text in the tips will also be searched when this is selected.

Type of match -- Select the type of search (where in the text the match must occur):

- **Contains text (anywhere)** -- The text to find can be anywhere in the cell or data field.
- **Starts with text** -- The text in the cell or data field must start with the text to find.
- **Has a word starting with text** -- Each "word" in the cell/field is checked separately, e.g. a cell with "Smith/Jones" will be a match for "Smi" and also for "Jone".
- **Complete match** -- the cell or data field must match the Find Text completely, e.g. "Smith" will *not* match a search for "Smit".

Direction (for grid searches only) -- select whether "Find Next" will search up or down from the current position.

Search All Record Data -- Select this to search all fields of the records shown, not just the text shown on the grid. Note that this option only tells it to search those exact records -- for instance if it's showing Reservation records (common with reports), it will **not** search the customer information because that's not in the

Reservation record (see Database Organization). In this case, if you want to look at customer information then you would also select the next option to search related records.

Note that for Text Filtering from within filters, this option is not shown since it's always assumed to be required (you're not searching a grid, you're searching all records of the given type).

Search Related Records -- Select this to include any other records linked to the records being searched (and records linked to those, and records linked to those, and so forth). This is powerful, but will also slow down the search considerably. For instance in a common search involving Reservation records, this option will cause it to also search every field in each of these records:

- o The Site record for the Reservation
- o All Transactions of the Reservation
- o All Journal entries for the Reservation
- o The Customer for the Reservation
- o All Reservations that the Customer has ever had
- o All Site records, Transactions and Journal entries for all of those Reservations

There are a few things specifically excluded even though they are technically "linked" to a reservation:

- o Guests of the reservation (because they are different customers)
- o Group Leader (because it's a different customer)
- o Non-synchronized linked reservations, which could be different customers

Be aware that you can't specify which data fields are included in the search, or even which related records, e.g. to only look at the customer's last name. Therefore be careful about searching for common words! For instance if you're looking for a customer named "Daily" and include related records, you're probably going to end up with every customer that has a "Daily Rate" transaction (unless you select the "Complete match" type of match)!

Report Options

Most tab view reports have an Options button. This is generally used to select which fields are displayed in the view. These settings are remembered, even after the program is shut down, so you only need to set them up for your requirements one time, and change them only when needed for a special printout, for instance.

Field Selection

Most reports allow you to select what fields are shown. Just check the fields you want to see on the report from the options available. The fields available for a given report are based on the way the report is commonly used -- for instance, there's generally no reason to see the customer's vehicle information on a transaction details report. Also, some fields are always shown and cannot be turned off. The order of the fields cannot be changed.

Deposits, Total Paid, and Balance fields -- These field options aren't actual fields in the record, but are calculated dynamically from all transactions in the reservation. Note that if you are using post-dated Charge transactions (as enabled through Program Options / Transactions), then the Balance **does** include any post-dated transactions. It's not simply the balance "as of today".

Auto-Charges and Auto-Balance fields -- If Auto Rates have been enabled, these column options will be available on some tab views. For pending and checked-in reservations, it will perform the auto-rate calculations for that reservation and show what the charges will be (Auto-Charges) or what the balance will be after applying any deposit already made (Auto-Balance). Note that this can take some time to calculate, so be careful about showing this column for a large number of reservations. There are some cases where it won't show a value. If the reservation has the auto-rates disabled, it will show "(Disabled)". Also it won't show a value for reservations that don't yet have a site assigned (since it can't auto-calculate the rate without a site), nor will it show a value for Owner reservations or Monthly reservations that are not pending. For Monthly

pending reservations, it will show the amount expected to be due upon check-in, according to the Monthly Program Options.

Days Overdue, Unpaid Nights, and Aged Balance fields -- These are special fields available only on the Payments Due tab view. For more information refer to the Payments Due section.

Include empty sites when sorted by Site

This is selected by default, and will show the vacant sites on the report in addition to occupied sites. This is handy for using the On Site report for a walk-around checklist, as it clearly shows which sites should be empty.

Include Sub-total rows when sorted by Site

When selected, blank separation lines with sub-totals of any numeric columns will be inserted when sorting by Site. This is normally disabled, since it would result in a subtotal after almost every row in most cases. However there may be times when it's desired, e.g. when doing a report for a longer time range.

Include Sub-total rows when sorting appropriate columns

When selected, blank separation lines with sub-totals of any numeric columns will be inserted when sorting by date or any appropriate field where sub-totals may be wanted, like Site Type, Reservation type, Rig Type, Status, etc.

Include Waiting-List reservations

This option appears on some reports, such as Arrivals, so that you can see if any reservations "would have arrived", useful as a reminder if you want to double-check for openings for the coming week, for instance.

Show reservations which fall in the date range

This option on the Unassigned and Non-Reserved reports, selected by default, will show any reservation that covers the selected dates, even if it started (or will start) earlier than the start date.

Include Owner reservations

If this is checked, Owner-type reservations will be included in the report. Since owner reservations are usually not associated with someone currently present, this is disabled by default on most tabs.

"Yesterday" button, "Yes/Today" button, and "Today" button

These options, only available for Departures and On Site, let you select which buttons are shown for quick date selection. You can select any combination (be careful, your screen size might not allow having all 3).

Query to add with additional information

This allows you to add additional columns to the report and/or apply filtering to the report, by setting up a Query containing the columns needed.

The Field Selection checkboxes should be used whenever the field or value you need is one of the Field options, but if you need fields or calculations that are not available as a field checkbox then you can create a special add-on Query and use it by selecting it from the list here. (Technically you could even uncheck all normal field options so it just shows the query.)

Important: Any filtering defined in the selected query will be applied to determine the records shown, *in addition* to the filtering specific to the tab view such as the From & To dates, Site Type, etc. -- only reservations or transactions that meet the normal tab view filtering conditions and *also* any Query filtering conditions will be shown. Thus you could even create a Query that has only Filter Conditions and no columns, if you simply want to add filtering to the tab view.

Pop-up Tips

Whenever your mouse moves over the grid in a tab view, you will likely see a variety of little pop-up messages. These are tips that give you a little more information, so that the grid can be smaller and still have the information easily available. For instance, putting the mouse over the last name of a customer will pop up their first names as well. If you hover over a Site name, the site's Description will pop up. And if you hover over the date headers on the Rack view, the full date will be shown if it's not already part of the header (e.g. if you turn off the options to show the Day of Week or Year in the header). Note that these tips will stay on the screen for a few seconds, and then will disappear until the mouse is moved again. The contents of this "Tip Text" for Reservations and Sites can also be customized -- see *Maintenance / Advanced Customizations / Tab Views*.

In addition to these pop-up tips when hovering, you can get detailed reservation or site information in the form of Quick-Info windows when double-clicking on a cell (although the double-click action can be changed, see *Maintenance / Program Options / Functions*). If a reservation occupied the cell, you will see almost all of the reservation's details. If you click on a cell with a site name or type (for instance the site headers to the left of the Rack), the Site's details will pop up. To close the Quick-Info window, just press the **ESC** key, or click anywhere outside the window, or click the "X" button in the Quick-Info window. The contents of this Quick-Info Text can also be customized -- see and *Maintenance / Advanced Customizations / Tab Views*.

Right-Click and Double-Click Functions

Much of the functionality of the program is available through the right-click context menus of the tab views. (In fact, many functions can *only* be done through the right-click menus.) This makes working with reservations extremely fast -- see it, click it, and it's done (in many cases).

When you right-click on a cell in the grid, a menu will pop up with operations available for the item you clicked on. This menu will be appropriate for the cell you click on, so it will change depending on which view you are on and which item you click on -- for instance, depending on whether it's the customer name, the site name, a blank cell, etc. Many times you will see one or more of the menu items "grayed out" (disabled). This means that some functions are not available for that cell due to its current state. For instance, you can't cancel a checked-in reservation, so that option will be disabled. You will also see some options change depending on a reservation's status. The software attempts to prevent illogical or impossible operations. See below for an explanation of the functions available through the right-click menus.

Double-Click Functions

In addition to right-click, you can double-click on a cell. By default, there are two possible results of double-click. On an "open" cell in the Rack (a site that's available for the date clicked on), double-click will open the New Reservation dialog, with the site and date already filled in. This is the quickest way to start a new reservation if you can see the desired site and starting date in the Rack view. The other double-click function is customizable (see below), but by default it will show a Quick-Info window for the selected reservation or site. This will happen for any double-click other than on open cells on the Rack. The Quick-Info window is a temporary window (just click somewhere else or press the **ESC** key to close it), but it shows most information for a reservation and in some cases will show information not available elsewhere, such as any conflicting reservations for that date. The contents of this Quick-Info Text can also be customized -- see and *Maintenance / Advanced Customizations / Tab Views*.

Note that if the Rack shows an Owner reservation in a cell, the site is still considered available so double-click will start a New Reservation as if the cell was empty (open).

Customizing the Double-click action

You can override the default double-click action for Reservations and Sites (except the "New Reservation" functionality for available site/dates) through *Maintenance / Program Options / Functions*. You can change this to do another common function that you would normally access from the right-click menu, or you can enter a custom Expression (e.g. to run a custom script). For further flexibility, you can specify a different double-click action for each of the Tab Views, through *Maintenance / Advanced Customizations / Tab Views*. This allows you to specify a different double-click action for each of the Tab Views, so for instance you can have it do Check In on the **Arrivals** tab, Check Out on the **Departures** tab, Assign Site on the **Unassigned** tab, and open Transactions on the **Transactions** tab.

Right-Click Menu Functions

View Reservation Quick-Info and **View Site Quick-Info** -- These are often the top selection in the menu, and are the same as double-clicking on the cell (opens a quick-info window).

Reservation Details, **Customer Details**, and **Site Details** -- These open the respective Details dialogs, where you can view and/or edit any of the corresponding details. Note that Manager access is required to change the Site Details.

Mark site 'Dirty'/Clean' -- Only available if the Site Dirty field is enabled, this will set or clear the "Dirty" flag for the site. If right-clicking on the Site itself on some tabs, like Arrivals and Departures, several other options will be shown to mark multiple sites as clean or dirty.

Site Work Orders -- If you right-clicked on a site name (not some other reservation field), this option will be available to take you to the Work Order list for the Site.

Find all Reservations for the Site -- This will open the Find Reservation dialog and show all reservations for this site (past, present, and future). This can be handy for seeing who the last person was in the site, or for seeing when the next person is due to arrive, if it's too far in the past or future to see on the rack. From there you can check the Reservation Details for each one.

View Unassigned reservations for this date -- This option only appears if you right-click on a cell that has "No Site" in it, indicating that one or more reservations exist for this date that have no site assigned. It will show a list of all unassigned reservations for the given date (similar to viewing the Unassigned tab).

Search Grid for Site/Customer -- This is the same as the Search icon on the toolbar and the **Alt-S/F9** function keys. It will open the Search prompt where you enter the site or customer name to search for.

Change Customer for the reservation -- This is only available if the reservation is a Group reservation and is not yet checked in. This can be used to change the reservation from the group name to an individual customer before they check in.

Check In and **Check Out** -- These will let you instantly check in or check out a reservation. If today's date doesn't seem to match the first or last night of the reservation as appropriate, you will be warned and given the option to change the date in the reservation to today (handy for early check-ins or check-outs). The Transactions dialog will appear so that you can review the customer's bill and adjust it as needed or print a receipt.

Auto-Checkout functions -- These functions can only be found on the right-click menu of the Departures tab view. See that tab view's information for details.

Transactions -- This will open the Transactions dialog and allow you to view transactions or enter new transactions for a reservation. See the section *Working with Reservations* for more information.

Confirm, **Guarantee**, or **Cancel Reservation** -- These do exactly what they say, opening an appropriate dialog as needed.

Assign or Change Site -- This will open the reservation dialog and allow you to assign a new site to a reservation, whether it already had a site assigned or not.

New Reservation for this customer -- This will open the New Reservation dialog for making an additional reservation for the same customer. The customer information will already be filled in. This will not affect the current reservation, and is handy for making future reservations for a current customer.

New Reservation -- (Rack view only) -- This option is available if you click on an open (available) site cell on the Rack view. It is the same as double-clicking on the cell, and opens a New Reservation dialog with the site and start date already selected accordingly.

Reserve for the site owner -- (Rack view only) -- This option will only be shown if you right-click on an owner-type reservation. This is like New Reservation, except that the owner will automatically be selected as the customer.

Add a Guest to this Reservation -- This will open the New Reservation dialog, but it's used to add a guest reservation. The site and dates of the selected reservation will be set automatically, so generally you only need to enter the customer information. You can also change the dates if the guest is not staying as long as the "host".

Linked Reservations -- This is used to add one or more reservations that will be linked to the reservation selected, or to change the type of linkage for the one selected. See *Working with Reservations* for more details.

Split Reservation at this date -- (Rack view only) -- Use this to make two reservations out of one, where one reservation ends the day before the date you clicked on, and the other begins on the date you clicked on. This is useful if you want to move a customer to a new site in the middle of their stay (split it, then use Change Site on the new half), or if they will leave for awhile and come back later (split it, then change the start date of the new half). If the split date is today or in the future, the second half will not be checked in yet (it will show a Pending status). If it's in the past, then both halves will keep the checked-in status (assuming it's checked in now). Note that a split must be done in the normal range of the reservation, not in a Blocked date range.

This is New Start / Last / Blocked Date -- (Rack view only) -- Use one of these three options in current or future reservations to quickly change the reservation dates right on the rack.

Remove Blocked Dates -- (Rack view only) -- If you click on the last date of a blocked range, you can use this option to completely remove the blocked dates from the reservation.

Extend Previous Reservation to this date -- (Rack only, on open site cells) -- Use this to easily extend a reservation (the one immediately preceding the selected cell in the rack) to end on the selected date. It will add days to the end of the reservation resulting in a longer reservation, rather than change the reservation's start date. Note that Owner-type reservations are ignored for this function.

Block Previous Reservation to this date -- (Rack only, on open site cells) -- Similar to Extend Previous..., this will add Blocked dates to a reservation (e.g. when you know that the customer might stay until this date but isn't sure yet, and doesn't want to be charged for the additional days yet.) Note that Owner-type reservations are ignored for this function.

Advance Next Reservation to this date -- (Rack only, on open site cells) -- This will change the start date of the next-in-line reservation on the rack to the selected date. (It will add extra days to the front of the reservation, not change the end date.) Note that Owner-type reservations are ignored for this function.

Make Site Available / Unavailable this date -- (Rack only, on open site cells) -- This will add or remove dates to the site's dates-unavailable or dates-available list as appropriate, changing the "available" status of the site for the selected day. This can be useful for scheduling short periods of maintenance on a site, or to indicate that a site was not available due to an emergency or electrical problem (even if it's a date in the past, this can be worthwhile for accurately calculating Occupancy reports). For longer changes in periods of availability, it may be easier to enter the date ranges manually in the Site Details dialog.

Print or E-mail for this reservation -- (Any view, if right-clicking on a valid reservation cell) -- This allows you to print a single receipt, envelope or other Form for the selected reservation, or if you have SMTP set up for E-mailing then you can E-mail a receipt or other form, or even send a free-form E-mail message. (The receipt or other format can be selected from the dialog that appears).

Print this view -- This is the same as using the Print icon, or **F8**, or File / Print from the main menu. It is here primarily for consistency.

Print or E-mail for all reservations -- (all but the Rack and Transactions view) -- In addition to "This View", which is the same as Print this view above, this has options to batch-print mailing labels, envelopes, E-mail lists, or custom forms or receipts for all reservations shown in the current view. (They can also be filtered further if needed, or you can select which ones to actually print, in the dialog that comes up.) If you have SMTP set up for E-mailing then you can Batch E-mail receipts or other forms, or even send a free-form E-mail message to everyone shown in the view.

Conflicting Reservation Details -- This option will only appear for conflicting reservations (reservations occupying the same site on the same date), and will be one of the few functions available in that case. This will show a list of all reservations conflicting with that particular site (using the Find Reservation dialog), so you can edit one or more of them as needed to fix the conflict.

Color Key -- This displays the Color Key dialog so you can see the meanings of the reservation status colors, and to change the colors used.

Grid Lines -- This will turn the grid lines on or off. A check mark will be shown next to the menu item if the grid lines are currently on.

Flip Orientation -- (Transactions view only) --When showing Summary reports on the Transaction view, you can flip the orientation so that dates are in rows and the category summaries are in columns. This preference will likely depend on how many dates or how many categories you are summarizing. The transaction orientation isn't saved in general, but will be saved with any "memorized" transaction reports.

Searching Reports

You can search for a particular Site or Customer on any of the tab views by pressing **F9**, **Ctrl-S**, or **Alt-S** (These are all the same function, so use whichever is easiest for you to remember). In some cases (e.g. when clicking on empty cells in the Rack view), you can also use the Search function from the right-click menu.

The main uses for this are to quickly scroll to a desired site on the Rack view, or to locate a site or customer on the other views.

When you press **Alt-S**, a small dialog will appear -- just type any portion of a site name, or the start of a customer's last name. It will first search for a site name containing the characters you entered (it will search both the abbreviations and the "Site Name" fields). If no match is found, it will then look for a customer. So for instance if you're looking for a customer with "Smi" in the last name but you have a cabin named "Smiley's", it will match the cabin first. Also, if the Reservation Label field is enabled then any labels defined for the reservations will be included in the search, if the label field is shown on the report (e.g. in the "Smi" case it would locate the first occurrence of *either* a customer's last name or a label starting with "Smi").

Either way, if a match is found then the view will highlight the matched reservation (scrolling to it if necessary). In the case of the Rack view, a match of the site name will highlight the first visible cell of the site and a match of the customer will highlight the first cell of the reservation. (Note that it will only search reservations from today to the last date of the Rack that can be scrolled to, corresponding to the Maximum Future Days setting.) On any of the other views, when a match is found the entire line will be highlighted.

If no match is found, a message will be shown with a couple tips with how to find what you're looking for (or why it might not have been found).

Tip: If you don't enter any search text and just press **Enter** (or click "Search"), it will scroll the report grid to the top. So just pressing **F9 / Enter** is a handy way to jump to the top without using the mouse.

Sorting Reports

All of the views except for the Rack view are tables where each line corresponds to a record and each column is a field of the record. The fields shown by default are appropriate for the selected view (use the [Options](#) button to change which fields are shown). By default they are sorted by date or other appropriate field, and whenever sorted by date there will be a blank line inserted between each different date for ease of reading the report.

You can have the report sorted by any field you like, simply by clicking on the column header for that field. A small arrow will be shown in the header, indicating the direction of the sort. If you want to sort the column in the other direction, click the header again -- each click will reverse the sort for that column.

Some views have an option (under the Options button) to include empty sites when sorting by Site. This provides better visual feedback for "empty" sites and is especially useful for walk-around checking, but also makes the report longer.

Blank separation lines with sub-totals of any numeric columns will generally be inserted when sorting by site, or when sorting by date or any other appropriate field where sub-totals may be wanted, like Site Type, Reservation type, Rig Type, Status, etc. This can be disabled if needed through the Options.

Also note that in certain cases, the program will automatically use a secondary sort. For instance when sorting by Site Type, all of the reservations with the same Site Type will then be sorted by site, and those on the same site will further be sorted by date.

Sizing Reports

As covered in the *Rack Options* section, the Rack view cells are a consistent width determined by the Cell Width setting. The other reports, which are columns of data fields, are auto-sized according to the text in the fields (the cells will grow as needed to avoid truncating the text). However, you can have temporary control over the cell widths if you want to adjust the report for printing. For instance, if you don't need some of the fields or if some columns are blank for all records, you can save space by shrinking those fields to almost nothing. This may reduce the number of pages needed for wide reports, or allow the font to be larger when using the "Fit to Page" print option.

To re-size the columns, place the mouse cursor over the dividing line between the column header cells. The cursor will change to a right-left arrow (similar to this: ←→). Then hold the left mouse button down and move the line to the width you desire. You can change the columns to any width, but be aware that this will likely result in truncating text, and since the ellipses (...) will not appear for text on these reports, there is no indication that part of the text is missing.

As mentioned, the resizing is temporary. It will remain the new size for printing or scrolling around, but any action that causes the report to refresh, such as sorting a column or making any reservation change, will cause all of the columns to auto-size again.

Printing Reports

To print the contents of any Tab View report, simply click the Print button on the toolbar (or select File / Print from the main menu). There are several options that can be used to customize the format of the reports, which are described in the *Printing Options* section of *Program Options and Settings*.

Besides those options, don't forget that you can print in Landscape mode to get a wider report on one page. To change to landscape mode, use File / Printer Setup / Default. The setting will be remembered even when the program is closed and restarted.

It's worth mentioning again that you should use Print Preview to see what the report will look like before printing it. This is because the size of the report and the settings (Fit to Page and Zoom Percent) can make the difference between getting a nice report or getting 20 pages that have to be taped together, or a report printed in such tiny text that it's unreadable. The Print Preview function also allows you to step through pages to see what's on each page, so you can select certain pages to print if you don't need the whole report.

If you prefer to print in black & white to save ink (or if you don't have a color printer), it may be a good idea to add the "Status" field to your reports, since the printout won't have the color coding. This is an optional field under the Options button on all views (except the Rack).

Once you select Print (either after Print Preview or instead of Previewing), printing uses the standard Windows print dialog. This allows you to select the page numbers to be printed, which printer to use, and other printer properties. Generally this only requires you to click OK on the Print dialog to send it to the printer. There is no need to wait for the entire document to finish printing -- once it is queued up for the printer, the print dialog will close automatically and you can continue working or print another report.

Exporting Reports to Other Programs

Any of the Tab View reports, as well as almost any report grid in a dialog such as Find Customer, can be exported.

Copy/Paste

You can also copy data directly to another program such as Excel, just by highlighting the desired cells on the grid (or press **Ctrl-A** to select all cells), then **Ctrl-Insert** or **Ctrl-C** to copy the data to the clipboard. Then you can switch to the other application and paste the data. The data is copied in Tab-delimited format, so it can be pasted into nearly any program that supports Tab-delimited data or text. However, only the data cells can be copied this way, not the header row and column. To get the entire report into another program, use the Export to CSV function.

You can also copy the Map view image in the same way (it copies the entire image).

Export to CSV

Exporting reports to a CSV file is covered in detail in the Import and Export Functions section later in the manual.

Rack Tab View (Reservation Grid)

Most of your operations will probably be done directly from the Rack view. This is the primary display, which shows the status of each site on any given date, typically showing the next 2 weeks. Reservations and open sites are color-coded to indicate their status, and each day of the week on open sites can be colored differently as desired (by default the weekends are slightly darker). Each cell in the grid represents one day of one site. There are several options available to customize the look of the Rack (see *Rack Options* for explanations), and there are controls at the top to filter the view.

Starting Date and the Red Yesterday/Today Divider Line

You will normally see a red line on the Rack between yesterday's cells and today's cells on the Rack. Normally this is a vertical line, but may be horizontal if the orientation is flipped. The purpose of this line is simply to indicate the start of current day, and is a very helpful indicator.

Note that by default the first column shown on the rack will be yesterday. This is so that you can see reservations that ended last night, since those customers are likely to still be on site in the morning. You can also tell (by color coding) whether they have been checked out yet, so you can tell that they might still be there. When scheduling new reservations, you may want to avoid placing someone in the same site as a reservation that "ended" yesterday unless they have checked out, in case they plan to extend their stay (or just haven't left yet, in the case of early walk-in customers).

Also note that the normal Rack starting date can be changed to a specific date through the Program Options. This is primarily useful if your park opens for the season at some time in the future, and you're taking reservations now. You can start the Rack on the first day of the season, so you can skip the "closed" period and don't have to scroll over every time.

Reservation Cells

Reservations are shown as cells filled with the last name of the customer (or the special reservation Label, if there is one). If the name is too long to fit, it will be truncated with an ellipsis (...) to indicate that it's not

completely visible. One cell for each **night** of the reservation will contain the name. The program deals in "nights" of the stay, so although most customers will actually leave the morning after their last night, the cell for the departure morning will not show that customer -- it must be available to show the customer staying the following night. Thus if a customer stays for one night, one cell will be filled with that customer's name. Of course if your business is a something like a flea market which operates only in "days" and doesn't have overnight stays, just treat "nights" as days and it works fine.

Moving the mouse cursor over any reservation (without clicking) will show the full last name as well as the first name(s) in a pop-up tip, and also the full Label if there is one. Double-clicking on a reservation will pop up a Quick-Info window or other function specified (see Program Options). Finally, right-clicking on a reservation will present a menu with all major functions available so that most operations can be done from this view. These functions are covered in the Common Controls section.

Reservation Label note: The "Label" is mentioned a couple times above. This is a special field, normally disabled, that allows you to change what shows on the Rack instead of the customer's last name. See the Reservation Label section of the *Working with Reservations* chapter for more details.

Pay special attention to conflicting reservations -- these are cells that are bright red with yellow text (these are the default colors, but this can be changed through the Color Key). Although it's very difficult to make a reservation that conflicts with another one through the normal procedures (the program will warn you and not allow it), it may be possible to cause conflicts by manually changing a reservation's data (for instance through the Maintenance functions). If you see a conflicting reservation, double-click on the cell to see a Quick-Info window showing the information for both of them. You can edit the first one with the normal right-click commands, but to edit the second one you may have to find it through one of the other views (for instance, Arrivals for that date).

Advanced users: the coloring of each heading row and column, as well as the reservations and open sites, can be changed by defining custom Color Schemes and selecting them as default Global Colors. See the Maintenance section for details.

Open Site Cells

Cells with no customer name are "open" sites. The color may vary depending on whether the day is a weekday or weekend, and whether the site is available on that date (according to season dates or special available/unavailable dates set for the site). Hovering over an empty site won't show anything, but you can see the site's description (and double-click to get a Quick-Info window) by hovering over the site name in the row or column header (the gray button-like cells). Double-clicking on an open site will open the New Reservation dialog (the quickest way to make a reservation for a known site and date that's visible). Right-clicking will pop up a menu with functions for the site, including options to extend or advance preceding/following reservations to this date.

"No Site" Cells

You may see "No Site:1" (or some other number) in a cell that should otherwise be open. ((If the full text won't fit in the cell, you may just see the number, or may see the "..." ellipsis and can place the mouse over the cell to see the full number.) This indicates that there are reservations for this date which have not been assigned sites, and this will appear in every open site cell for each date that has unassigned reservations. This is essentially a warning that you should not fill the open sites for that date until the unassigned reservations have been assigned sites, or that you should at least leave enough sites open to satisfy the unassigned reservations.

To assign sites to the reservations or to cancel accidental unassigned reservations, you can go to the Unassigned Tab View where they will be listed for the date range selected. Alternatively you can right-click on a "No Site" cell on the Rack and select "View Unassigned reservations for this date". From there you can view the Reservation Details for any unassigned reservations and use "Assign or Change Site" to assign it to the proper site, or if it's an accidental duplicate you can Cancel or Delete the reservation.

A reminder about double-clicking to make a reservation (or the equivalent New Reservation function from the menu or toolbar) -- be aware that this will make a **new** reservation, even if you select an existing customer from the database. This is **not** the way to assign sites to reservations that have already been made without site assignments, since the original reservation without a site assigned would still be in the system.

Availability Summary Display

You can optionally include a row below the date header that shows the number of sites available for each day or period. If you prefer, this can be shown as a percentage. Note that the availability number shown will depend on the site types selected -- if All Site Types are shown, then the number includes all types. If you select only one type, then the number includes available sites of only that type.

If adding the row for this is too distracting, you can set it to only show the availability as a pop-up tip when you put the mouse cursor over the date. If the availability by site type is more appropriate, you can also show the availability as a pop-up tip in the site type column. When you hold the mouse cursor over a particular site type, the availability will be shown for the date range selected.

Note that if any of these availability options are selected, it can cause the Rack display to refresh much more slowly when you have a large database.

Rack Controls

Date range selection was covered in the *Common Controls and Settings* section above, but the dates on the rack have some special meanings since it's not a normal table-type report.

You'll notice that the program starts with both the start and end date set to the current date, but obviously the Rack is showing more than one day. The date range is of primary importance when the Available Only option or the Show Range option is selected, but the controls can also be used to change the Rack dates shown.

The default date range available in the Rack is determined by the past and future minimum days and maximum days settings (see *Rack Options*). You can use the date controls to see dates further in the past or future -- just change the date in the control to extend the range of the Rack. This won't necessarily scroll the Rack to the dates selected, especially when selecting the End date -- you will still need to scroll the Rack view after selecting a new end date.

If the Available Only option is selected, then the Rack will only show those sites that are available continuously from the Start date to the End date selected. (Options for what is considered "available" are covered in the *Program Options and Settings* section.) So by default, if you check the Available Only box, it will show all sites that are available today. This is a quick way to see what's available for a given date range before starting a reservation. Once you know the available sites, you could double-click on one of them to start the reservation process.

Note that if Available Only is selected, the From and To dates selected for the rack can automatically be used as the First and Last nights for a new reservation (when you double-click on an open site). This option can be enabled or disabled through Program Options. If Available Only is **not** selected, the date of the cell you double-clicked on will be used as the First night, but it will only assume one night.

If the Show Range option is selected, then the Rack **does** only show dates in the range selected. This is primarily used when you want to print a Rack view, so that you only print the dates you want. Otherwise it would print all of the rack currently available for scrolling, which is probably a lot more than you want.

The Site Types drop-down will filter the Rack to show only the selected type or class, or "All Site Types". Note that this also affects the Available Only option, in which case only the available sites of the selected type will be shown. Also note that if a Default filter is defined, this will also be used for the New Reservations dialog.

The Reset/Today button is handy for resetting the Rack to its default state after scrolling it or checking availability. This sets the date range back to the default, makes sure that the current day (or previous day depending on the settings) is the first row or column shown, clears the Available Only and Show Range options, and resets the Site Types selection to All Site Types.

The Options button opens a dialog with various settings for customizing the appearance of the Rack. These settings are saved and will remain the way you set them every time the program runs.

Rack Options

All of these options are used to affect the way the Rack is displayed (the main dynamic interactive report screen). A description is given here of each option, but more information may be found in the *Rack (Reservation Grid)* section. Note that they also affect the mini-rack view on the **New Reservation** dialog.

Dates-across-the-top orientation -- This is the normal orientation for the Rack. If you prefer it with Sites across the top and dates down the side, then uncheck this option.

Show Date Header -- Controls whether the date is shown across the top of the grid (or site, depending on the orientation). The only real reason to disable this is if you select a query to completely replace the normal date header, e.g. to show it in a different format

Show Day of Week in header -- Controls whether the day of the week (Mon, Tue, etc.) is shown for each date header cell. While this can be helpful, it does take extra space on the grid.

Show Year in header -- Controls whether the year is shown for each date header cell. Helpful if you do a lot of multi-year reservations, but most users leave it off to save the grid space.

Show Site Abbreviations -- Controls whether the site abbreviation (e.g. site number) is shown as the first column in the grid. The only reason to turn this off is if you choose to use a specific query to replace all of the site header columns (see below).

Show Site Types -- Controls whether the site type is shown next to the site name in the grid. This can be useful if the site names show no clue as to their type, for instance if they are all just numbers.

Show "Dirty" status -- Only available if the Site Dirty field is enabled, this will add a column that will show "****" for sites with the "Dirty" flag.

Show # sites available each day, in a separate row -- When selected, a row will be added below the date header to show the number or percentage of sites available each day. The number will only include available sites of the selected site type (or other filtered selection). Note that any unassigned reservations will be subtracted from the number shown, since they will occupy sites when they check in. However it will not know which site type(s) will be occupied by unassigned reservations, so the number is subtracted no matter which site type is selected (possibly resulting in a negative number available).

Show # sites available each day, as pop-up tips -- When selected, the availability information will be included as a pop-up tip in the date header cells. Usually there's no need to select both this option and the separate row option above, since they show the same information.

Show # sites available for each site type, as pop-up tips -- When selected, the availability of sites for a particular type will be shown as a pop-up tip on the site type column cells (assuming you have Show Site Types selected also). The availability shown will be for the date range selected in the Rack.

Show availability as a percentage -- When selected in conjunction with any of the availability options above, it will show the percentage available instead of the number of sites.

Query to insert with additional site info -- If you want to see more (or different) information for each site in the grid, you can create a Query to be shown in addition to the normal site "headers" (or in place of them). Any columns defined in the query will be inserted before the grid part of the Rack (after the site abbr and/or type if they are shown). **Important:** if the Query selected has any Filtering defined, then that filtering is also used to determine which sites are shown.

Query to insert with additional date info -- As with the site info query, you can create a Query to be used in addition to (or instead of) the normal date "headers". Any columns defined in the query will be inserted before the grid part of the Rack (below any of the normal date header options shown).

Default future days -- This defines how many days in the future will be available for instant scrolling on the rack, regardless of future reservations. In other words, a value of 31 will allow you to scroll over to see at least 1 month in the future, without having to change the End date in the header. Note that the actual number of days shown may be greater (up to the maximum, below) if there are reservations beyond the minimum future days value.

Default past days -- The number of days in the past that will be available for instant scrolling, before the Start Date must be changed in the header. (This is also the minimum past days shown.)

Note that the settings above don't limit the ability to view or create reservations. They only help minimize the number of cells in the Rack that the program needs to keep visible under typical usage conditions, to increase response speed. If your computer is fast enough, there is no reason you can't set these to show a full year in each direction by default, so that you rarely have to change the dates in the header and can simply scroll to the desired dates.

Cell Width -- The default cell width for the rack is 50 (measured in pixels, or "screen dots"), so that the date header will display fully. While this allows the most possible grid cells to be shown at once, it may truncate more of the customer names than you prefer. You can increase the cell width to see more complete names. A good medium value is 55, which will allow most common names to fit and still allow nearly 2 weeks to be shown at once on screen with 800x600 resolution. Alternatively, you can reduce the cell width to get a "compressed" view. For instance, set it as low as 3 to see several months at once. This would most likely be a temporary setting, due to the time it takes to display and the lack of names & date information. (Dates will be compressed as the size is reduced, but after a point it can't show date headers). However, the pop-up tips on both the date headers and occupied site cells will still be shown.

Start Rack with yesterday by default --For convenience in seeing who might still be in the park, this option is enabled by default so that the Rack shows yesterday as the first column. A red line separates yesterday from today as an indicator, and to help avoid making new reservations on the wrong date. If this becomes too confusing or you just don't need to see who was on site yesterday, you can turn this off so that the rack starts on today.

Note: The From and To dates on the rack are not affected by this option -- they will still default to today, so that the Available Only function only shows those available today. This can create a slight bit of confusion when using the date-stepping buttons (the arrows on each side of the date). Stepping back one day won't change the first column of the rack, since it's already showing yesterday. On the other hand, stepping forward one day will appear to jump 2 days because the rack will now go from starting yesterday to showing tomorrow. It makes sense when you consider the actual dates selected, but may be a little confusing at first.

Show bars at the start and end of reservations -- This option (enabled by default) helps you visually separate back-to-back reservations by drawing a small vertical bar at each end of a reservation on the rack. This can be especially helpful if you print the rack in back & white. If you don't need the bars and prefer a "cleaner" look, you can disable this function.

Show Unassigned reservation counts in open sites (e.g. "No Site: 4") -- By default, any reservations made without a sites assigned to them will show up on the Rack as a "No Site" notation in *open* site cells for the corresponding dates. This serves as a reminder that there are some reservations on that date that still need sites assigned (so don't fill in all available sites with other reservations!). To see the details on these reservations, you need to go to the Unassigned tab view. However, you may prefer to turn this notation off just for aesthetic reasons, for instance if your normal practice is to leave reservations unassigned until they arrive and checking the Unassigned list is part of your normal routine.

Include Waiting List reservations in unassigned sites count -- When this is checked, any waiting-list reservations with unassigned sites will also be included in the No Site count, so you know that someone may be waiting for a site on that date. Disable this option if you don't want to include waiting-list reservations.

Show Owner reservations -- If this is checked, Owner-type reservations will be shown on the Rack. The sites will be considered "open" in most respects, but appropriate right-click functions will be available on owner reservations. If most of your sites are owned, you may wish to disable this for a cleaner display.

Hide a site if it's unavailable for the entire shown date range -- This option allows you to minimize the number of sites listed in the rack, showing only those that are available for at least part of the date range shown. This can be particularly useful if some sites are only available during certain seasons, or if a large number of sites are currently unavailable for an extended time due to renovation. See the Sites Setup Dialog section in Maintenance Functions for more information on season dates and special dates.

Show only "XXXX" in occupied sites instead of customer names -- This option will eliminate the customer names from the Rack, primarily for use when printing the rack as an availability chart that might be viewed by the public.

Map Tab View

The Map view is optional, and requires that you have a suitable map bitmap (image) file available. This tab will appear automatically once a map is set up (under [Maintenance](#) / [Park Setup](#) / [Maps](#)).

The map view is an image representation of your campground, with indicator "elements" placed on each site to show the status. If necessary, you can have multiple maps to represent different areas of your park, or multiple parks -- or even use multiple images to represent the same area but with different aspects (e.g. a separate map showing additional overflow spots available during special events).

Note that when printing a map view, it will automatically be sized to fit on the page. (If printing in Portrait mode, it will fit to the width of the paper but will generally fill only the top half of the page.)

Most of the controls on the map are similar to the Rack -- you can select the From and To dates to show status for a date range, Reset to today, and select the Site Type, Site Class, or Park to show.

Selecting a Map

In addition to the typical controls, there is a drop-down list for selecting which map to view. If you have only one map, of course, this is ineffective. If you have multiple maps, you can select the map to view from the list, or you can cycle through them with the arrow buttons on each side of the list.

In addition to the selection list/buttons, you can use the Page Up, Page Down, Home and End keys to change map pages. Note that the "focus" has to be on the map to do this, so if the key doesn't work, click once on the map first.

You can also place "hotspots" on a map that will change to a selected map when clicked on. This can be used to "zoom in" on a section of an overview map, or you can set up "buttons" on a map image and click on those to change maps.

Options

There are just a few options for the map view:

Default Map -- This selects the default map shown on program start-up and when the Reset/Today is clicked. You can also leave the default blank, in which case the first map will be shown by default, but the map will not change when Reset/Today is clicked. (The map order can be changed in Setup, so you can still specify which map shows up first by changing the order.)

Use reservation color coding -- Select this if you want to see the status for reservations colored exactly as on the Rack and other tab views, rather than the generic coloring for reserved/occupied (map colors). This only applies if there is only one reservation occupying a site for the selected date range. If more than one reservation occupies the site for those dates, it reverts to the generic reserved/occupied colors for the map.

Show Owner reservations -- If this is checked, the appropriate status color will be shown for Owner-type reservations if no other status applies. This is generally the same as "available" except for a lighter color text, but can be useful if trying to locate available sites with or without an owner.

Color Key

The map has a separate color key to determine the color for site indicators. This is a simpler color key, for the most part indicating whether a site is open, occupied now, or reserved (not yet occupied). If it's open, it can also indicate that a site is unavailable, "blocked" by a reservation, or it should be open today but yesterday's occupant has not yet been checked out. Conflicting reservations are also indicated, and if you have a site type filter selected (e.g. showing only Tent sites), then any sites that don't match the criteria are considered "inappropriate" and will be shown in a different color (normally dark grey).

The color key can be viewed and colors changed from the right-click menu or from the [View / Color key for Maps](#) option.

Site Status and Interaction

As described above, the site indicators will be filled with an appropriate status color -- either from the simplified Map color key or from the Reservation color key. Generally any status color other than the "open" color (normally white) indicates that the site is not available for reservations. The one exception is the "may be available" color (normally a very light green). This indicates that there is no reservation for the current dates, but there is someone checked in to that site that is supposed to be leaving. This means that the site should probably be checked before putting someone in it, since the current occupant may not have left yet. Once the occupant is checked out, the site will return to Open status.

Interaction with the Map view is similar to the Rack. When you move the cursor over a site indicator, a pop-up tip will show the current occupant name, or the site description if there is no occupant. If an occupant is due out today, their name will be shown with a note that they are due out today.

Double-clicking will work the same as on the Rack -- if there is an occupant, it will show the quick-info window or other function specified for double-clicking Reservations (see Program Options). If there is more than one occupant for the selected date range, a list of occupants will be shown, and you can view the details of each one from there. If there is no occupant and the site is available (even if there is an occupant due out today but not yet checked out), a New Reservation window will appear, starting a new reservation for that site. The dates will default to the From and To dates selected. If the site is unoccupied but not available or inappropriate for the selected type, it will show the quick-info window or other function specified for Sites (see Program Options).

Right-click functions are also similar to the other views, as appropriate for the site clicked on (if you click outside a site indicator, the functions are limited to printing and viewing the color key). One exception is that if the site is open for tonight but last night's occupant is not yet checked out, the right-click menu is similar to an

open site's menu but has a "For the reservation due out today" sub-menu, where you can access functions for that reservation. From there you can check out the reservation, view details, and other related functions.

Copying the Map to the Clipboard

You can copy the entire map image to the clipboard, including the current site status indications. This could be pasted into other documents, for instance. To copy the map, first click somewhere on the map to make sure it has the keyboard focus. Then use the standard Copy command, either **Ctrl-C** or **Ctrl-Insert**.

Arrivals Tab View

The Arrivals view shows all reservations with the First Night in the selected range (defaulting to today, but this is easily changed with the controls). This view is handy for seeing who is due to arrive today. When a camper arrives you can quickly go to this list, verify that they have a reservation, and check them in directly from the list (using the right-click menu). Toward the end of the day, you can refer to this list to see who has not arrived, or perhaps who has arrived but did not get checked into the system. You'll notice that the Name column (the customer's last name) will be color-coded according to the reservation status just like the Rack view. This gives an instant indication of their status at a glance, so you can see which reservations have been checked in.

Note: The Options allow you to select Yesterday and Today besides just the Yes/Today button for quick date selection. The initial dates shown on this tab default to Yes/Today if that's enabled, else Today if that's enabled, else Yesterday if that's enabled (if none of them are enabled, defaults back to Yes/Today).

There's a special control at the top, Pending Only, which when selected will limit the list to those who have not yet checked in (Owner-type reservations will also be excluded, since they don't indicate an actual arrival on their start date). This is handy if you have a large number of arrivals for the day, so the list will shrink as you check people in. You could also use this option to create a no-show list of people you need to call at the end of the day for a status update. Note that Day passes will not be shown as pending since they are assumed to be checked in automatically.

There is an option (under the Options button) to include empty sites when sorting by Site. This provides better visual feedback for "empty" sites and is especially useful for walk-around checking, but also makes the report longer.

Note that reservations on the Waiting List can also appear on this report (if this option is set under the Options button). These will be highlighted with * *Waiting* * in front of the customer name.

You will also see reservations with unassigned sites on this report, which will show "(No Site)" in the Site column.

Departures Tab View

The Departures view shows all reservations with the Last night in the selected range (defaulting to yesterday and today, adjustable with the controls). This view makes it easy to see who might be leaving today. (Yesterday is shown as well as today, since those whose Last Night is yesterday will likely check out this morning.) You can switch to this view when somebody checks out, quickly find their reservation and check them out of the system using the right-click menu. If most of your customers pre-pay rather than checking out when they leave, you can use this report to get a list of people who should be leaving today, print it out and make the rounds to check to see if they have left as scheduled. You can then check them out to "close out" the reservation.

Note: The Options allow you to select Yesterday and Today besides just the Yes/Today button for quick date selection. The initial dates shown on this tab default to Yes/Today if that's enabled, else Today if that's enabled, else Yesterday if that's enabled (if none of them are enabled, defaults back to Yes/Today).

There is a special control at the top, Pending Only, which when selected will limit the list to those who have not yet checked out (Owner-type reservations will also be excluded, since they don't indicate an actual departure).

This is handy for shrinking a large list to show who has not yet left the campground, or to show what sites still need to be checked for vacancy on the next rounds. While the Name column is color-coded to show which reservations have been checked out, the Pending Only option is still useful if you are printing in black & white mode, and of course to reduce the length of the list. Note that Day Passes will still be shown since they are assumed to be on site any time during the day (they don't "checked out"). They can be excluded by selecting "Assigned Sites" from the Site Types list.

There is an option (under the Options button) to include empty sites when sorting by Site. This provides better visual feedback for "empty" sites and is especially useful for walk-around checking, but also makes the report longer.

Note that reservations on the Waiting List can also appear on this report (if this option is set under the Options button). These will be highlighted with * *Waiting* * in front of the customer name.

Bulk check-out

The right-click menu of this tab has special "Auto check-out" functions that can be used to set the departing reservations to Checked Out. Selecting one of these options will check out the reservations indicated, assuming they are "qualified" -- e.g. they must be currently checked in, their Paid-thru Date is set to their Last Night (or later), and they must have a zero reservation balance. If the reservation has any Guest reservations, they must also have a zero balance and be due out on the host's last night or earlier, and the Guests will be automatically checked out also.

Auto-Checkout Today's Shown departures -- Selecting this option will check out only qualifying reservations currently shown on the Departures list, if their last night is equal to yesterday's date (i.e. departing today).

Auto-Checkout All of today's departures (shown or not) -- Selecting this option will check out ALL qualifying reservations with a last night equal to yesterday's date (i.e. departing today), regardless of whether they are currently shown on Departures (e.g. any filtering on the Departures tab is ignored).

Auto-Checkout All Shown departures (Any dates) -- Selecting this option will check out ALL qualifying reservations currently shown on the Departures list, regardless of their Last Night. This can be used for example to catch up check-outs of older reservations, by setting the From date as far back as needed. Note that the default operator access level required for this option is Manager.

On Site Tab View

The On Site view shows all reservations that occupy sites for dates in the selected range (defaulting to yesterday and today, which shows any customers that may currently be on-site). The report is sorted by the site by default. This view is primarily used as a quick reference to who is currently in the campground (especially with Current Only selected, see below). It's handy if you need a list for security gate or walk-around purposes, or if someone calls the office looking for a customer. By changing the dates you can see future occupancy, so for instance you could use it to get a list of all campers who will be here on a holiday.

There's a special control at the top, Current Only, which when selected will limit the list to those who are currently checked in (eliminating those who have not yet arrived and those who have already checked out, and also eliminating Owner-type reservations). This will result in a more accurate report of who is actually present.

Note that Day Passes will still be shown since they are assumed to be on site any time during that day and do not check in or out. They can be excluded by selecting "Assigned Sites" from the Site Types list.

There is an option (under the [Options](#) button) to include empty sites when sorting by Site. This provides better visual feedback for "empty" sites and is especially useful for walk-around checking, but also makes the report longer.

Note that reservations on the Waiting List can also appear on this report (if this option is set under the [Options](#) button). These will be highlighted with * *Waiting* * in front of the customer name.

Unassigned Tab View

The [Unassigned](#) view shows all reservations that have not been assigned to specific sites. As with the other views you can specify a particular date range. However, this view defaults to a 1-month view (from today to 31 days later) so that you can easily see upcoming reservations that need to be assigned to sites. Their rig information and any special requests (site preferences) are shown to make the task easy. You can assign a site to a reservation by right-clicking on the reservation line and selecting [Assign Site](#) (see [Working with Reservations](#) for details).

Note that the date range can be applied to either the First Night of reservations (only showing reservations which start in the date range), or to a reservations' entire stay (showing any reservations which include the date range). This is an option under the [Options](#) button so you can set it either way.

If you want to see all unassigned reservations in the system, regardless of the dates, it's easier to use the [Unassigned Reservations](#) function under the [Reservations](#) menu, rather than changing the dates as far back and forward as possible.

It's common to have reservations on the Waiting List with unassigned sites, so those can appear on this report as well, if the option is set (see the [Options](#) button). These will be highlighted with * *Waiting* * in front of the customer name.

Non-Reserved Tab View

The [Non-Reserved](#) view can show several different types of reservation records that are not actually "reserving" space, based on the Reservation Status field of the reservations. These can be:

- [Waiting List](#) reservations (you didn't have a place to put them yet but they still want to stay).
- [Inquiry](#) "reservations" (they just inquired but did not make a reservation).
- [Couldn't Book](#) reservations (they tried to make a reservation but you were full so they won't wait).
- [Canceled](#) reservations (the customer canceled a previously pending reservation)
- [Canc'd/No-Show](#) reservations (the customer did not cancel but did not show up)
- [Canc'd/No-Stay](#) reservations (the customer showed up but did not stay the night)
- [Canc'd/Mistake](#) reservations (the operator canceled a reservation for some reason)
- [Canc'd/Other](#) reservations (canceled or some other reason)
- [*Any* canceled](#) reservations (all types of cancellations combined)

You can also show "All Not Reserved" to show all types in one report. Both the color coding and the [Status](#) column will indicate which type they are. By default the display shows "All Not Reserved" reservations. You can change the default through the [Options](#) button. The other types are selected using the drop-down list on the right end of the controls above the grid.

Note that the date range can be applied to either the First Night of reservations (only showing reservations which start in the date range), or to reservations' entire stay (showing any reservations which include the date range). This is an option under the [Options](#) button so you can set it either way.

Alternatively, if showing only Canceled reservations, you can show them according to the Date Canceled (see the [Options](#)).

Like the Unassigned view, this view defaults to a 1-month (31-day) date range so that you can check ahead and call customers if a site opens up. Of course if you're showing Canceled reservations by Date Canceled, then future dates are meaningless so you would need to adjust the From date to show prior dates.

Note that the Status column will also include the Cancel Reason selected for any canceled reservations. For instance, "Canceled : Mechanical trouble". Alternatively, you can show the Cancel Reason as a separate column instead (see Options).

If you would like to change the status of any of the shown reservations, right-click on it and select [Reservation Details](#). You can change the status there.

Payments Due Tab View

This report has many different uses -- besides just showing reservations that owe a balance, it can show long-term reservations with rent coming due, or it can show any upcoming arrivals that haven't paid a deposit, or it can be used to look for mistakes made (e.g. payments that weren't entered properly, or charges not reversed for canceled reservations).

With the original default settings, the Payments Due view shows any reservations that might have outstanding payments due, as of the selected date (defaulting to today) -- see details below. Whether payments are "due" is determined by the Paid-Through Date for reservations, so it's important to make sure that each reservation's Paid-Through Date accurately reflects the payment status. (This field can be set every time a transaction is made and the customer checks in or out, or a payment is made.) You can filter it further with the options available through the [Options](#) button (see below).

By default the report is sorted by the Paid-Through date of the reservation, so the most-overdue accounts are at the top. If no Paid-Through date has been set, then the First Night is used for sorting, and you might see "(Deposit)" in this field if they have made a deposit but no further payments, or "(Payment)" if they have made a payment.

There's also a [Show All With Balances](#) option on this report, which will show any reservations with non-zero balances due (unpaid charges on their transaction history), regardless of their Paid-Through date. Reservations with zero balances will also still be shown if they are shown according to the [Options](#).

"Show any due as of..." date

The date selection for this report is a single "Show any due as of" date, rather than a From/To range, since a range doesn't make sense for this report. Thus changing the date or using the Week/Month/Year buttons can be used to show payments that are coming due in the future.

It's important to understand how this date affects what is shown, especially if you don't have "[Show all with balances](#)" selected. Primarily, assuming you have the "Checked In" option selected in the **Options**, this is compared against the Paid Through date of the reservation -- in other words, if Paid Through is earlier than the "Show any due as of" date, then the reservation will be listed *even if it does not have a Balance Due according to its transactions*. In other words, this completely ignores what the reservation's actual balance is or whether payments have been made. This is mainly of interest for long-term (e.g. Monthly) reservations, to show which ones have an upcoming balance due even though the charges have not been added yet. Of course you will see past-due as well.

Using different Options as described below, the "Show any due as of" can be used different ways. If you're including "Pending" reservations, this date is the "as-of" date for the "days ago" or "days from now". In other words, this is time-shifting the report -- e.g. if you're showing Pending reservations "made more than 10 days ago", it will really show any made more than 10 days before the "Show any due as of" date, not 10 days before "today".

This date is also used when showing columns for Aged Balances Due -- e.g. "120 days" will show balances more than 120 days older than the "Show any due as of" date, not 120 days older than "today". So again, this can be used for time-shifting, e.g. to see balances "as of" some date in the future or past.

Options

Many of the options for Payments Due are different than other Tabs. Proper selection of the options is critical to making Payments Due show the proper information. As mentioned above, the primary/original usage is to show reservations coming due according to their Paid Through date. Selecting other options can override this or add other reservations to the list.

Show any reservations with balances (same as "Show all with balances" checked in the main tab view) -- Check this if you want to see **any** reservation with a balance due, regardless of its Paid-Through date. If you also want to see any with negative (credit) balances, then also select "**Include credit balances**".

Use Customer balances instead of individual reservation balances -- Check this, *in addition to* "Show any reservations with balances", if you want to see **all** reservations owned by any customer with a balance (even if that particular reservation has a zero balance). This is useful for finding mistakes where a charge or payment was entered on the customer instead of the reservation.

Include linked synchronized and sub-member reservations -- Check this if you want to include the linked reservations (even though the linked ones don't usually have their own balance if all transactions are done on the linked master).

IMPORTANT - If "Use customer balances" or "Include linked" are selected, be aware that the Totals on this report will likely include duplicate balance amounts since they are shown multiple times!

Show reservations which are... -- This section allows filtering which reservations are included by their status and payment status. The options should be self-explanatory so we won't cover each one in detail. Select one or more options as needed.

- **Pending** -- This will allow you to see future reservations according to when it was made, when it starts, and whether a payment (deposit) has been made or it has a balance. This can be useful for instance to see reservations that still have deposits due. Note that "Confirmed" and "Guaranteed" reservations are also included even though the option just says "Pending".
- **Checked in** -- This is normally the one you want checked, so see those currently on site with a balance due and/or payment due according to their paid-thru date.
- **Checked out, etc...** -- Include this to see ones that normally shouldn't have a balance, to help find issues that need cleaned up.

Fields

The report can show these special fields:

Reservation Balance, Tot. Customer Balance and **Non-Resv. Balance** -- These are according to the actual charges and payments applied to the reservation or customer (not some assumed future balance due). Note that the Tot. Customer Balance includes balances from **all** reservations for the customer (past and future), as well as any transactions on the Customer record that are not on any reservation. The Non-Resv. Balance will be only transactions on the Customer record that are not on any reservation. (Note that depending on the filtering options, a reservation may be shown that has a \$0.00 balance even though a payment is due, e.g. for the next month, or because they have a Customer balance.)

Days Overdue -- This is the number of days since the last Paid-Through date (or their First Night, if they have not paid yet).

Unpaid Nights -- This is calculated as the number days from the last Paid-Through date (or First Night) to the end of their reservation (not including Blocked dates). Thus this is often larger than the days overdue for monthly customers, and smaller than the days overdue in most other cases.

Aged Balances Due -- There are special fields available under Options that can show "Aged" account balances, such as you might see on a credit statement. These will show how much of a reservation's balance is Current or 30, 60, 90, or 120 days old, and are used for special accounting purposes. These fields require more calculation than the others, so leave these turned off unless you need them.

Important -- The "Current" column does *not* mean "balance currently due". It means any part of the balance due *more recent* than the next Aged Balance option selected (as of the selected "Show any due as of" date). For instance if you have only "Current" and "90 days" selected, "Current" will only include any balance more current than 90 days.

You can select one or more of the aged balance field options, depending on what time frames you need. The column headers will adjust to reflect the actual ranges being used (e.g. "30-60" or "30-90"). Assuming you have the "Current" option selected, the total of all aged amounts shown (including Current) will be the total balance as of the selected "Show any due as of" date -- however it will not include *post-dated* charges, e.g. due after the selected date.

Aged balances are unique in that they use the date selected in "Show all due as of" as the starting point. So for instance if you enter a prior date, all transactions after that date are ignored. Thus you can use this report to find out how much each customer's balance was as of a particular date in the past. In this case, the total of all of the aged balances may not be the same as the "Balance" (or "Customer Balance") amounts because those balances include all transactions regardless of their dates. However if today's date is selected, then all of the aged amounts shown will total up to the Balance shown.

The dates for 30 days, 60 days, etc. are also figured from the date selected, not from today. Therefore you could also enter a future date and it will show aged balances that are 30, 60, etc. days back from that date.

Another important thing to note is that the aged amounts may be shown for either for the Reservation or the Customer's transactions (which may include other reservations or non-reservation transactions), depending on whether the option "Use customer balance" is selected or not.

Queries Tab View

The Queries tab is only shown if there is at least one custom Query defined. In addition to the basic Query tab view where any Query can be selected, there may also be other Query tabs set up to show specific Queries -- in other words, custom tab views created from Queries. See Tab Views Setup for details on setting up custom tab views.

It has From and To date selections and a Today button like most other tabs but these might not have any effect, depending on the Query selected.

The main thing on this tab is the Query selection list (unless it's defined with a specific Query as mentioned above). This drop-down list will show all Queries defined. Simply select one of the queries, and a grid will be shown with that query. This may include a Total row as appropriate, and will have all of the typical functionality of grid-type reports -- scrolling, sorting by column, pop-up tips (if defined in the query), and blank/total lines inserted if sorted by certain columns (again, if defined by the query).

An Edit Query Definition button allows you to easily access the Edit Query function for the selected query (if you have the appropriate access level). If there isn't a specific Query selected, then this button will take you to Queries Setup.

A Query may have a "Text filter" option -- the note "Filtered Text:" will be shown to the right of the Edit Query button if this option is available for the selected Query. If so, then the normal Search (F9) function will allow entering text that's used in the query's filter conditions. If search text is already entered, it will be shown next

to "Filtered Text:". Using this functionality you can create custom "Find" type queries and access them easily here.

The right-click menu on a Query tab will depend on the "Base Table" of the Query being shown. If it's a Reservation based Query then it will have typical reservation functions like most other tab views, and a Transactions-based Query will have typical transaction functions like the Transactions tab, etc. Likewise for Customer and Site based Queries. If the Query is based on any other table, then the right-click menu will just have a few options, including options to print Forms for one or all records, toggling the grid lines or printing the view.

Transactions Tab View

Overview

The Transactions view is different in many ways from the other views. The most obvious difference is that this view shows a list of transactions rather than reservations, and since each reservation is likely to have multiple transactions, a single reservation will result in multiple lines in the transaction list. This view has more filtering options and shows more totals and sub-total information than other views.

Some reservation information is shown for reference and sorting convenience -- the last name is color-coded as usual, plus the first names, site, site type, and first night are shown. Also note that some transactions won't have reservations associated with them, and some won't even have customers associated with them. This will be the case for unbound transactions, as well as any Expense and Misc. Income transactions that you enter for the business.

The other major feature of this view is that it can be used to generate many different summary reports. This makes it much more powerful than the other views -- and much more complex as well. For a better understanding of how to use this report, refer to the *Working with Transactions* section as well.

One thing to remember is that like the other reports, this is a dynamic report. So whenever transactions are made, they will show up immediately. This is a good thing, unless you are showing many days of transactions (or a summary report) and have a slow computer. Although it will only refresh when the view is visible so it won't slow down normal operations, it would still be a good idea to reset the view to Details mode for Today (uncheck the Summarize option and click the Today button) after getting the reports you need.

Detail Transaction Reports

This is the default mode, and is indicated by the Summarize check box being unchecked. Each line will show a separate transaction record (with subtotals as appropriate, described below). If you've loaded some other report or filtering and want to get back to the full list of transaction details, click on the Details Options... button, and then click Reset the view to details / all transactions.

You can select which fields are displayed through the Options... button (or it will be called Detail Options... button if your screen resolution allows).

Dates

By default, the view shows today's transactions, sorted by date (and time, since they are all the same date). Since all transaction types are shown, the charges and the payments would balance out to a \$0.00 total at the bottom if all charges and payments entered today correspond to each other. This is often not the case, however, since charges are often posted to a reservation on a different day than the payments.

If you prefer to show transactions by the date of their reservation (to make it easy to check for reservation charges and payments balancing out), you can change this in the Filters dialog. Click the [More Filters...](#) button in the control area, and check the option to [Use Reservation date instead of transaction date](#). Now the transactions will be grouped by the date (First Night) of the reservation, and the total and subtotals (if any) should balance out for any reservations that are paid in full.

As with other reports, you can select the start and end date for the report. (If you're using the option mentioned above to Use Reservation Date, then the date range filtering will likewise apply to reservation dates rather than transaction dates.) Since you're likely to have many more transactions in a day than reservations (and you should have no transactions for future dates), there are no Week/Month/Year buttons. To get monthly, quarterly and yearly reports, see the Summary Reports section coming up later.

Shifts

If you have Shifts functionality enabled, you may want to filter your report by the shift. The Filters dialog contains fields to do this, but remember that the dates are also used for filtering -- so if you have a night shift that spans 2 dates, be sure to include both dates in the filter.

Sorting and Totals

You can sort the detail transaction list many ways by clicking on the column header as in other reports. You will notice that sorting by some fields will result in groupings with sub-total lines between each group. This provides a quick way to get mini-summaries for Transaction Types, Categories, Pay Methods, Discounts, Site Type, Site, and Operator. The sub-totals for each group can be useful for some daily accounting tasks -- sort by Payment Method to get the total receipts for cash, Visa, Discover, etc., or sort by Type to get the total Payments (receipts), Tax charged, refunds, etc.

Some of the totals and subtotals need to be explained further. In addition to the total number of transactions at the bottom of the list (and subtotals after each group), you will see values under the Qty, Each, and Total columns.

The [Qty](#) total is self-explanatory, although not terribly meaningful unless the list is sorted by Category since otherwise the quantities for days rent, supplies, propane and so forth would be mixed together. (Depending on how your categories are defined, some Qty totals may not be useful in any case.)

The totals under the [Total](#) column would seem obvious, but keep in mind that some transaction amounts are added to the total while others are subtracted, even though the individual transactions almost always show a positive amount. For instance, any "Charge" transactions, including Taxes, are considered negative values, and receipts like Payments and Deposits are positive. Expenses are negative, Misc. Income is positive, Refunds are negative, and so forth according to whether the amount would be a credit or debit to the campground. (Also note that when viewing Reservation balances and printing reservation receipts, these values are reversed since they are from the customer's perspective -- charges are positive outstanding balances, while payments subtract from their balance.)

It's important to note that if you accept advance Deposits, the totals on the detail report probably won't mean much. For one, Deposits are added just like Payments, not reflecting true income. In addition, Deposits Applied also affect the total here, even though they don't affect the actual balance due for reservations, etc. So if you're not filtering out these transaction types, the overall total won't be meaningful.

As if this wasn't confusing enough, you have the option to show all totals as positive for summary reports -- more on that later, since it doesn't affect the Detail view.

Finally, there are the amounts shown in a Totals row for the [Each](#) column. These are calculated as an average -- the Total divided by the Qty. Obviously these values only make sense in the cases where Qty makes sense, and when the transactions are sorted/grouped by something like Category or Type which will

separate the charges from the receipts. The option to show these is disabled by default -- click the [Detail Options](#) button to turn the option on or off, "[Show the average amount as the total of the Each field column](#)".

Interpolated Details

If the summary option is selected to interpolate categories for payments, then the details shown will not be real transactions -- they will be interpolated, or calculated, from the original transactions. These are similar to "split" payment transactions, or a result of prior deposits applied to particular categories. Since they're not real transactions, the values will be shown in grey instead of black, and the description will show "(Interpolated)".

This is usually due to using the Receipts by Category quick-report and then unchecking the Summarize box to view the details. This is useful for locating the source of transaction amounts that appear in the Receipts by Category report -- even though they're not real transactions, they act the same way. You can right-click on them to view the reservation or customer transactions that the result is coming from.

Editing Transaction Details

If you have the proper access level you can edit transaction details or delete transactions. It can't be done directly from this report, but you can right-click on any transaction and select [Transactions](#) from the menu to open the Transactions dialog. From there you can view the transaction details and make changes as needed. Refer to the *Working with Transactions* for more information.

Filtering Transaction Reports

There are many filtering possibilities with the transaction reports. The most common ones, Transaction Type and Category, are available as drop-down lists in the controls area (if the screen resolution is high enough for them to fit). The others are available on the Filters dialog, accessed through the [More Filters...](#) button.

Resetting the filters: If you've loaded some other report or filtering and want to get back to the full list of transaction details, click on the [Details Options...](#) button at the top of the Transactions tab view, and then click [Reset the view to details / all transactions](#).

Drop-down List Filters

As with the Site Types filtering in other reports, when selecting a filter you are choosing to see only those records (transactions) of that type or category. Note that if you see "-----" in one of the drop-down lists, it means that a more complex filter has been defined from the filters dialog, which can't be shown in the drop-down list.

For Categories, you can select a single category or "All Categories" from the drop-down list, or select any number of categories from the Filters dialog. Keep in mind that Charge type transactions are about the only ones that will have your defined categories, since other types like Payments have their own "payment" category. Thus if you select the "Propane" category, you will see the charges for propane, but not the taxes or payments that are probably associated with it. (This is generally what you would want to see in any case.)

For Transaction Types, you can choose a single transaction type, All Transaction Types, or one of two special groupings from the drop-down list -- All Receipts or All Charges. More specific filtering can be done through the Filters dialog.

Filter Dialog

From the Filters dialog, you can have additional filtering for Payment Methods, Discounts Used, and Operators. Each of these is presented as a multiple-selection list box. This means that you can select a single item in the list (click on it), or you can select any number of items at once (hold the **Ctrl** key down when you click on each item). Note that you can also unselect an item with Ctrl-click also. To disable filtering for a particular field, you can either select all of the items the list or unselect all items. You can also use Reservation Filtering to select the sites or reservation types you want to include, which uses the Reservation Filtering dialog, and also filter customer and unbound transactions by what kind of balance exists for the customer or unbound-set.

Note: If you want to exclude **all** transactions associated with reservations (e.g. to see **only** unbound or customer-only transactions), you can do this by going to Site/Reservation filtering, then uncheck all 3 of the "Include if balance.." options. Therefore it won't include any reservations regardless of balance, thus no reservation transactions will be included. (There will be a warning just in case you do this by mistake.)

The flexibility of filtering any or all of these fields can be useful for customized reports, but you will need to be familiar with the way transactions are defined to avoid mistakes. For instance, if you try to filter by the Cash payment method and the Good Sam discount, your report will be empty because payment methods only appear in Payment transactions and discounts only appear in Charge & Discount transactions -- so no transactions would meet both filter criteria.

Date filtering

You can also set the dates in the Filter dialog. While the dates shown here initially are the same as the ones in the Tab view controls, you can also select one of the pre-defined date ranges like "Today", "MTD", "Last Year", etc. These simply calculate the appropriate start and end date for the From and To date fields -- you will see the dates change as you click on the buttons. However, they are especially important when memorizing reports. If the date selection is set to anything other than Custom Dates, that selection will be saved with the memorized report -- so for instance you can define a report for Last Month, and it will always be for last month -- the dates won't have to be selected manually every time you load the report.

In addition to the date range, there's an option for whether to use the transaction Posting Date (usually desired for reports), or the Date Created (which can never change), or the Resv. First Night. The "Date created" option should generally not be used for reporting, but can be used when searching for transactions entered on a certain day, for instance. The "Resv First Night" option is also dangerous for reporting, but could be helpful when you want to see income generated for a certain group of reservations, regardless of when the charges were actually entered or the money actually received.

Also note that if Posting Date is used, then there is an option to Include post-dated transactions. This should normally be disabled, since you don't want post-dated transactions on the reports (e.g. prior to a reservation to being checked in). However you can enable this if you want to see these "pending" transactions in a report for future days. This also assumes that you're using the Post-dating option from Program Options / Transactions. It does not consider transactions manually altered with future dates to be "post-dated" -- only those automatically post-dated by the system when the post-dating option is enabled.

Shift filtering

If you have Shifts functionality enabled, you may want to filter your report by the shift. The Filters dialog contains fields to do this, but remember that the dates are also used for filtering -- so if you have a night shift that spans 2 dates, be sure to include both dates in the filter (or select All Dates). You can select the Current Shift, Last Shift, All Shifts, or a Custom shift range and enter the shift numbers.

As with the date filters, the shift range type (Current, Last, etc.) will be saved with memorized reports. This makes it easy to set up a memorized report for the Current or Last shift, or All shifts.

Text Filtering

Click this button to set up a text search so it only include transactions that have a data field matching certain text (handy for filtering by the "description" field). Optionally it can deep-search to also look for a match in the related customer/reservation fields, e.g. to look for all transactions belonging to a unique customer name. See Text Filtering for details.

Resetting the filter to see all transactions

The [Reset Filtering](#) button is a handy way to clear all of the lists, resetting to "no" filtering and back to "today". If you don't want it to change the dates or shifts selected, use the [Reset all but dates](#) button.

Summary Transaction Reports

All of the summary financial reports available in Campground Master are generated from the Transactions view. You can go to the Summary Report Options dialog by checking [Summarize](#) and then using the [Options...](#) button (or just click the separate "[Summary Options...](#)" button if your screen resolution allows it), for full report control and some pre-defined Quick Reports.

Summary reports are basically a condensation of the detail reports to just the group subtotals in one dimension, with the ability to show multiple days, months, or years in the other dimension. So summary reports are shown as a grid with dates across the top and group summaries (Types, Categories, Pay Methods, etc.) in each row.

You can also flip this orientation (like flipping the Rack view), so dates are in rows and groups in columns. This can be done either through the Options dialog or from the right-click menu. Another option that can result in nicer looking reports is the Grid Lines option in the right-click menu. Turning off grid lines and printing in color to show the shaded "total" rows and columns (*Print Black & White* option turned off) will result in a very professional-looking report.

You have all of the same filtering options for Summary reports as you do for Detail reports, through the Filters dialog, so you can refer to those sections for filtering information.

Simple Summaries, Directly from Details

You can generate a quick and simple summary of the detailed report you're viewing by using just the control area in the Transaction view. Select a date range and a Type and/or Category filter as needed, click on a header to sort by one of the grouping fields (Type, Category, Pay Method, etc.), and click the Summarize check box. The resulting summary report will group by the field that you sorted and the dates in the range you selected, showing one row for each day and one column for each Type/Category/etc. Note: if there are more than 10 days in the date range, the orientation will default to dates in columns. If you prefer a different orientation, right-click anywhere on the grid and select "Flip Orientation". You can then print the report with the Print icon on the toolbar.

Getting out of a Summary Report

Once you use Summary Options to run a Quick Report or any other summary, you may want to get back to the default Transactions tab view display of showing all transactions for the day. The quick way to do this is to click [Detail options](#), then click the button [Reset the view to details / all transactions](#).

Quick Reports

From the Options dialog you can select one of several Quick-reports. These are predefined sets of filtering and grouping for the most common reports needed. You may first select a Summarize period and a date range (from the Filter dialog or in the control area of the tab view), since the Quick-report selections don't affect these, and then click the appropriate Quick-Report button.

Once a Quick-report is generated, you are free to change the filter or options if you like. While many people find that a couple of these reports contain everything they need, they were really intended as examples to show you some of the things you can do with the reporting options & filtering. For the most part they don't actually change to a particular report mode, they simply set the filters and groupings for you to generate a particular type of report. You're encouraged to "play" with them to get more specific information as needed, for instance you could add filtering to see only certain categories or to see income from only certain sites. Also remember that you can uncheck the "Summarize" button afterwards to explore the detailed transactions that are going into the report.

If a quick-report is printed without any changes to its filter or options, the name of the report will be used as the header on the printout.

The available quick-reports are described below:

Receipts by Payment Method - This is commonly used as a "Z-out" or "cash-out" report for verifying the cash drawer receipts for the day. It includes all Payments and Deposits (less Refunds) entered, grouped by the payment method (cash, check, Visa, etc.). To get a list of each receipt transaction grouped by the payment method, uncheck the "Summarize" box after generating the report.

Charges by Category - This can be used as a detailed income report if you're using an accrual accounting method (e.g. if you enter charges that may not be paid right away, thus carrying an accounts receivable and/or deposits balance). It will include all Charges, Taxes, and Discount transactions entered, totaled by Transaction Category. (Remember you can add more categories or change the existing ones through the Pick Lists functions.) As with other summary reports, you can uncheck the "Summarize" box to see the details.

Receipts by Category - This will report actual money received according to category, and is commonly used for cash-accounting systems (you only report income as it's received, and don't carry an Accounts Receivable balance). The details of this report are extensive, so see the separate Receipts by Category topic that follows later if you have any problems understanding the report.

Discounts by Discount Used - this will include only Discount transactions, grouped by the Discounts list (e.g. Good Sam, AAA, Seniors, etc.). Since it only reports the amount discounted, it's mainly used as a statistical type of report to see how much you're "giving away" in various discounts. If you want to see other information such as the amount of charges grouped by the discount used, then select the Charges by Category report and then come back to Summary Options and select the Discount Used for the grouping.

Taxes by Tax Category -- This is similar to the Charges by Category report, except that it only shows the Taxes transactions. As with Charges by Category, this report shows taxes collected as of the dates they were entered -- this is another important reason that we don't recommend entering charges until the reservation is checked in, because if you add charges when you make the reservation, this report will show that you collected sales tax when you made it rather than when they actually paid. See "Taxes Setup" in the *Maintenance Functions* chapter for proper setup and reporting procedures for taxes.

Income & Expenses -- This includes the "receipts" types of transactions, Payments, Refunds and Deposits, plus the Expense and Misc Income transaction types. This can be used as a very simplified income report. If you use the Misc Income and Expense transactions to track other finances, then it will include those also.

Balance Charges & Payments -- This is mostly useful if you always try to make sure that no Charges are entered until the day they're paid (e.g. when they check in), and likewise no Payments are entered without corresponding charges. In simple terms, it reports the difference between Payments and Charges (also accounting for previous Deposits applied as if they were payments on the day the charges were added). The

report is grouped by operator, so it's a quick way of determining if you have a particular operator who isn't entering "balanced" transactions as they should. What you "want" to see here is \$0.00 in every total, meaning the day's transactions are balanced..

Deposit Account -- This report is for tracking an advanced deposits account, for instance if you treat it as a liability in your accounting. It shows how much in new Deposits was received, and how much in previous deposits were Applied to new charges that day (e.g. check-ins using their deposit, which effectively depletes the deposits account). It also shows the Deposit Transfers, which should really always be \$0.00 if there aren't lopsided transfers, and also any manual adjustments made to the deposit account. Note that in addition to the daily changes, this report shows an All-Time column which reflects the actual balance of your advance deposits account.

Accounts Receivable -- Similar to the Deposits Account report, this is used for tracking an A/R balance and includes the various types of transactions that affect such a balance. Note that to Campground Master, any Charge that's not Paid is considered A/R. For instance if you put charges on a reservation when they make it rather than when they check in, it's considered A/R until it's paid.

Inventory Sales, by amount (Point of Sale only) -- This shows all inventory items and the total sales amount for the given period. Tip -- to see only the items that actually had sales, go back to Summary Options and check the box "Hide items with zero totals". If you prefer to see the report just by Inventory Class, you can also change that in Summary Options.

Inventory Sales, by quantity (Point of Sale only) -- This is like the previous report, but shows the total quantity sold rather than the sales amounts.

More Summary Options

For more control over the summary report, click the Summary Options... button if present, or click the Options... button making sure the Summarize check box is checked first. The top area of the Options dialog allows you to select the grouping method (Select one of the options, or None to show only one grand total instead of group totals) and the Summarize period (Daily, Monthly, Quarterly, Yearly or none). If you have Shifts functionality enabled, you can also summarize by shift. Note that selecting None for both grouping and summarize period will result in a single total value -- not terribly useful for a report!

Keep in mind that the date range selected in the filter (or tab view controls) takes precedence over the Summarize period. So for example if you summarize Monthly and selected the date range of 4/1/2001 to 5/1/2001, it will show April and May month summaries in the report but will actually be reporting for only one day in May due to the 5/1/2001 ending date. This could result in a misleading report.

There are some other options you can select for the report, plus a button that opens the Transaction Filter dialog (this is same as selecting More Filters... from the control area in the tab view). Feel free to experiment with different settings (and try the Quick-Report options below). You can't hurt anything by changing the settings.

Hide items with zero totals -- This option is useful for reports such as category reports. When selected, only the categories (or other groups) will be shown that have non-zero totals, so the report is smaller. Of course if you're grouping by Operator, for instance to see if the charges and payments balance out, then you would **not** want to hide the zero balances -- the zeros are what you want to see.

Blank zero amounts in group totals -- Assuming you're not Hiding the entire row for zero totals with the above option, you can select this option to blank them out, to make it easier to spot the non-zero amounts.

Blank zero amounts in body -- Select this option to show blank cells instead of \$0.00 in the "body" of the report, to make it easier to spot the non-zero amounts.

Show charges & expenses as positive values (invert) -- This option is useful for reports that would normally show negative values, such as a Tax category report. (Since taxes are charges to the customer, they are considered a negative amount). This will create a cleaner-looking report.

Show Deposits Applied as payments -- This option will obviously only be useful if your report includes Deposit Applied transactions. Examples of this are the Balance Charges & Payments report and the Accounts Receivable report. Normally the Deposit Applied transaction is considered a negative deposit (payment), so that it negates deposit transactions in terms of the overall Deposits Balance. In these reports, however, it's necessary to consider deposits applied as positive payments so that the balances are correct.

Include cumulative totals for each period -- When this option is selected, two extra rows (or columns) will be added to the report, showing Previous and Cumulative Totals for each date period. This could be used to seeing a running balance, or it may be useful when exporting values to graphing software like Excel. Note that the first period's "Previous" total will be zero unless you also use the option to include all prior dates (below).

Include group totals for all prior dates -- This option is used when you need an all-time total, for instance when calculating the Deposits or A/R balance. It adds 2 extra columns (or rows) to the report, showing Prior totals and All-time totals for each group (e.g. each transaction category). Obviously it can only include prior transactions that are actually in the database, so "All-time" means since you started using the software, or since you last purged old data.

Interpolate Category for Payments -- This is a special-purpose option, primarily used for the "Receipts by Category" report. Payment transactions don't have category information (because a single payment could be entered for any number of charge items with different categories). Selecting this option tells the software to figure out (interpolate) what transaction categories each payment should be applied to. If charges for more than one category were paid for, then the payment will be divided proportionally between the categories.

Include Deposits in Receipts by Category -- This only applies if the Interpolate option is selected. If Deposits are included, then they will be shown in the report as of the deposit date. However they might be reported as "Uncategorized" because they usually appear before any charges are entered. If you need the report to show all receipts as of the date received, then this option should be checked. You may also want to check the next option (include Deposits Applied).

Include Deposits Applied in Receipts by Category -- This only applies if the Interpolate option is selected. If Deposits Applied are included, then the applied amounts will be shown as received on the date applied (rather than the date the deposit was actually received). It should be used in conjunction with the previous option to include Deposits, so that the amount will also be deducted from the "Uncategorized" amount to offset the total receipts for the day. Basically the amount will be "moved" to the correct category on the date it's applied, without showing an additional amount received on that date.

Memorized Reports

Setting up the reports the way you like them can be a chore, and can result in accounting inconsistencies if you don't use the same settings each time. To avoid this, you can save the settings once you have them the way you like, and call up the same settings every time. There is no limit to the number of different reports you can memorize.

To memorize a report, open the Options (or Summary Options) dialog once you have the settings (filter, groupings, summarize period, orientation and other options) the way you like. Note that every setting in the Filters and Options dialogs will be saved to a memorized report **except** the specific dates -- obviously you would want to use different dates each time you run the report. If you select one of the date range selections, such as All Dates, Last Month, YTD, etc., then that selection will be saved with the memorized report and the dates will set appropriately whenever it's loaded. Likewise, Shift range selections (if enabled) will be saved with the report.

Click the Save Report button, and you will be asked for a name for the report. You can make this name as long and detailed as you like, but try to keep it small enough to fit in the Memorized Reports list on the dialog.

Click Save and the report settings will be memorized under that name. You can also delete reports as needed by selecting the report name and clicking the Delete button. You can overwrite a memorized report by selecting it in the list before clicking Save.

To recall a memorized report, simply open the Summary Options dialog, click on the name of the Memorized report you want, and click Load Report. The option settings will automatically change to the saved settings (except the dates, as mentioned above). Then click OK to generate the report, or you can click on Filter... to select a date range (You can also select the date range from the controls area on the tab view, but the Filter dialog has the handy buttons for Month-to-Date, etc. that you might prefer to use.)

You can also load a report and immediately View it in either summary or details mode, using the View Report and View Details buttons. (Alternatively you can just double-click on the report name, which will do the same as View Report.) These will automatically load the report, close the dialog, and change to details mode if desired, eliminating the extra prompt and clicks necessary to close the dialog and view the report.

If a memorized report is printed without any changes to its filter or options, the name of the report will be used as the header on the printout.

Quick guide to set up and use a memorized report:

1. Use an appropriate Quick-report to start with (something close to what you need).
2. Go back into Summary Options and select any other options desired, and any filtering you want.
3. Click Memorize, enter a name.

Now to use the report:

1. Go to Summary Options.
2. Select a memorized report.
3. Click either View Report or View Details, depending on whether you want the summary view or details view.

Alternatively you can use Load Report, but this will only load up the filter and option settings -- if you just click "OK" after that, it will do the same as View Report -- but you can also change filters/settings after Loading it if needed. But again, a Quick-report ignores all filters and most settings and resets things to exactly what's needed for the default quick report.

Note that double-clicking the report name (in step 2 above) will do the same thing as Load Report (saves a step).

Receipts by Category

This Quick-Report is rather unique in that it "interpolates" the amounts from transactions instead of using raw transaction amounts. Thus the amounts in a particular category may not seem correct (e.g. a payment doesn't all go into the category expected), or an amount appears in "Uncategorized" and it may not be clear why.

Since this report uses "interpolated" amounts rather than raw transaction amounts, it will divide a payment proportionally into the categories that need to be "paid", or accounted for, at the time of payment. When a bill isn't paid in full, e.g. for long-term guests, this can cause confusion. The other primary issue is when payments are entered before the charges to be paid, so that at the time of payment there are no categories to put the payment into (causing "Uncategorized" amounts).

Here are a few tips on resolving or at least understanding these issues...

The first thing to do when you see something unexpected in the report is to uncheck the "Summarize" box at the top. This will switch to Details mode and show the individual "interpolated" transactions -- e.g. a single payment may be shown as several interpolated amounts into different categories. These details are sorted by category so it should be easy to locate the problem area. To further investigate an item, you can right-click on it and select Transactions as usual to get to that reservation's transaction details. Here you may see that a payment is out of order, or that it wasn't paid in full at some point.

If a payment is out of order, probably causing Uncategorized amounts, you can correct that easily. First close the Reservation Transactions if that's still open, then right-click on the line again and go to Reservation Details. From there click on Transaction History. Select the payment and use the Move Up or Move Down buttons to put it in the right place (usually at the bottom, or at least below any Charges that it's paying for). Note that this doesn't change the dates so it won't affect reporting by dates -- it will only affect the distribution of the payment in the Receipts by Category report.

By the way, if you normally receive a payment before charges can be added, e.g. before they arrive, then that really should be entered as a Deposit. Once charges are added, then the money is "moved" from Deposits to the appropriate categories (this is one purpose of the "Dep Applied" transactions you see added automatically).

Refunds -- As with Payments, Refund transactions should be entered after the adjustments to Charges that are related to the refund, e.g. use Reverse Charges or enter Discounts or negative Charges first to get the balance to be refunded, then enter the Refund transaction.

Note: When you uncheck "Summarize" on the report to see the detailed transactions, the Refund transactions will be shown with their "refund amount" in the Each and Total columns. So for instance if there was a refund of \$50 in a category, it will show as a positive \$50. However that amount must be considered negative (subtracted) to arrive at the total for the category.

Assigning specific categories to a payment...

Sometimes you may receive a payment that you want to put in a specific category (or categories) instead of letting the program split it up. For instance if the customer has a \$50 balance due for rent, then you add an electric charge of \$50 and they pay only the \$50 for electric, the program would normally split the payment into \$25 rent and \$25 electric.

The only way to change this distribution is to manually assign categories to Payments. You will first need to enable this feature -- go to Maintenance / Program Options / Transactions, and check the box "Allow transaction categories to be selected for payments" (and click OK).

Now when you enter a payment, it will allow you to assign one or more categories to it. You can also correct allocations for previous payments -- as in the example above, right-click on the transaction in the details list and select Transactions to get to the Reservation Transactions dialog. Click on the Payment transaction to be categorized, and a button "Edit Category Allocation" will appear at the bottom. Click that button and add one or more categories as needed.

You can also use the Edit Category Allocation function for Refunds, Deposit Applied transactions and Payment Transfer transactions. (Deposits themselves can't be categorized -- they must be "applied" first).

Hopefully these tips will help you understand and correct any discrepancies in the report.

Other issues that can result in Uncategorized or inappropriate categorization

Besides the common issues of out-of-order payments and partial payments, there are a few other issues that can cause anomalies, described below.

Credit balances -- if a credit balance (overpayment) exists on a reservation, then that payment cannot be categorized. Be sure that credit balances are handled appropriately whenever possible, e.g. transferred to another reservation where it's used to pay for a charge, or at least into the Customer record where it can be used for a later reservation. It will still be Uncategorized in this latter case, but once it's transferred to a new reservation with charges, then it will be "deducted" from Uncategorized so that it balances out in the long run.

Incorrect manual category assignments for previous payments -- If you're already assigning categories to some payments manually (as described above), then this can cause problems if a mistake is made. Later payments will be automatically allocated to balance the categories to the charges seen, "fixing" any mistakes in the process. For instance if you had a \$50 Charge for Daily Rate but then allocated the Payment to Monthly Rate, then it would report that \$50 payment in Monthly Rate. If you later added another Charge (say for \$10 in electricity) and a Payment but did not manually allocate the Payment, then it would see that Monthly Rate had too much allocated and Daily Rate not enough, due to the mistake. So it would allocate -\$50 to Monthly Rate and \$50 to Daily Rate, in addition to the \$10 in electricity. Obviously confusing on the report for the new payment, but technically correct since the overall payment allocations are now correct.

Changes to charges or payments after manual allocations -- If you assign a payment to category manually, and then either change the amount of the payment or the amount or category of a charge preceding that payment, then the manual allocation is now unbalanced (unless you remember to correct that also). This has the same result as an incorrect allocation above.

Incorrectly deleted "Deposit Applied" transactions -- As mentioned elsewhere in the documentation, the Deposit Applied transactions are added automatically by the program to properly account for deposits being applied to the charges. If you delete a Deposit Applied without deleting the Charges, etc. that resulted in it, this results in throwing off your Deposits balance as well as the Receipts by Category report, since it no longer has a record of that deposit moving into the correct categories. Likewise, deleting Charges without deleting their Deposit Applied will result in the deposit going into Uncategorized.

Orphans -- if there are orphaned transactions, then the categories can't be interpreted correctly (it will appear as if charges or payments are missing). Be sure to fix these through Maintenance / Database Maintenance.

Bad Links -- If there are "bad link" conditions in the categories of transactions (e.g. if a category was deleted causing a bad link), then it won't know how to categorize a payment. While there is a function under Database Maintenance to "Repair <bad links>", this will only set it to 0, which is still an unknown category. You would need to locate each transaction with a missing/bad category and select the appropriate category for it.

Missing Receipt/Invoice # -- If there is no Receipt #, e.g. if this field was disabled through Data Field Definitions / Transactions, then it can't link Unbound or POS transactions to determine the payment category. While it's not possible to disable this in current versions, older versions may have this disabled (so any Unbound transactions done in an older version could have this issue).

Payment Transfer Mismatch -- If there is a Pmt Transfer mismatch (one side deleted but not the other), this can cause a problem since it depends on these canceling each other out to \$0 received for the day. Use the function under Maintenance / Database Maintenance to look for unmatched payment transfers. If one is found, you need to delete it and re-do it if necessary.

Misc. Income an Expense transactions -- If you're using a version prior to 7.0, a bug can result in these not showing properly. This has been fixed in version 7, and the fix also applies to transactions entered prior to upgrading.

5 Working with Reservations

Overview

Keeping track of reservations are naturally the main purpose Campground Master. Most functions of the program revolve around the various tasks involved in recording reservation information, locating that information when needed, making changes, and keeping historical data for reporting purposes.

One important thing to remember that "Reservations" are **not** the same as "Customers" in Campground Master. "Reservations" are records that contain the information about a single stay for a particular customer. Most of the actual customer information is stored separately in a "Customer" record, and the reservation only references that customer by an internal number. There are many reasons for this, but the main reasons are efficiency and continuity -- the customer information only needs to be stored once, no matter how many reservations that customer makes over time. Likewise, if you change the customer information, it's automatically changed for all of that customer's reservations.

Starting a New Reservation

The way to start a reservation (or at least the quickest way) will vary depending on the circumstances. For instance, if you're entering a reservation for a walk-in customer and you have the Rack view showing, the quickest method would be to double-click on the cell for today, on the desired open site. That instantly sets the site and the start date for the reservation, saving two steps. If you are taking a reservation on the phone for some time in the future, the quickest way is probably to click on Phone icon on the toolbar (New Reservation).

If you prefer getting all of the customer's information first, it may be easier to use the Add New Customer function (faces icon), enter the customer information, and then click New Reservation on the Customer Details dialog. Or if you're making a returning reservation for a customer that's leaving today, you can flip to the Departures tab, right-click on the customer's name and select New Reservation for this customer so the customer information is already filled in.

Here's a complete list of ways you can start a new reservation:

- From the file menu, select Reservations / Add New Reservation. (**Alt-R, A** from the keyboard.)
- From a Customer Details dialog, click the New Reservation button.
- Click on the New Reservation (phone) icon on the toolbar.
- Double-click on an empty cell in the Rack (the site and start date are automatically filled in).
- Right-click on a customer in any of the tab views, select New Reservation for this customer (the customer information is automatically filled in).

Two other functions can result in new reservations being created, but are used in special cases:

- Right-click one a reservation in the Rack, and select Linked Reservations, and one of the Add functions.
- Right-click one a reservation in the Rack, and select Split Reservation at this date.

Reservation Types

The reservation type is very important, and governs how the reservation is treated. This will default to "Normal", which should be used for typical reservations, but the actual options available will depend on the types defined in the Reservation Types Pick List (any of the types can be renamed or disabled if your park has no need for them). A description of each general type ("base type") is below:

Normal -- A short-term reservation, primary occupant of the site for the designated nights. (It can also be used for long-term reservations that you don't want to include in monthly billing.)

Group -- Similar to a Normal reservation except that it allows linked reservations to have a "group leader" referenced on the Reservation Details. This is typically used for reservations with multiple linked sites, and it allows easy customer changes (from the right-click menu on the Rack) as each group member confirms or checks in to the site. Group reservations also appear in a different color on the Rack, with the group leader in a slightly darker color. See the *Groups and Linked Reservations* section for more details.

Free Stay -- This can be selected for reservations where no charge will be due for the site. This option will only appear for operators with Manager access or above. Free Stay reservations will generally show no charges if auto-calculate is used, and will not appear on Monthly Billing even if they are long-term.

Guest -- This is a special type of reservation, and can only be created through the Manage Guests function on Reservation Details. A Guest reservation occupies the same site as its host (thus many reservations can be made for the same site, presumably temporary guests of the primary ("Normal"), or "host" reservation. Since they are separate reservations, they can have their own charges just like other reservations, and will appear on reports like Arrivals, Departures, and On Site. On the Rack view, guests will be indicated on the pop-up tip when the mouse hovers over the cell, and will also be shown in the Quick-Info window (e.g. when the reservation is double-clicked). See the section on Guest Management for further details.

Day Pass -- A Day Pass reservation is a simple reservation with first/last nights (usually just 1 "night"), and no site assigned. If day passes are enabled, it's actually easier to use the Day Pass button on the bottom of the dialog to make a day pass reservation, particularly if they are already present and ready to "check in".

Monthly -- Monthly reservations are similar to Normal reservations. Use this type if the reservation is a long-term reservation that will pay monthly instead of all at once. Reservations must be Monthly in order for them to be included in the Monthly Billing function (see *Working with Transactions*). This can also aid in filtering these kinds of reservations for reports, and makes the reservation appear in a distinct color on the Rack and other reports. Depending on the settings in Maintenance / Program Options / Monthlies, selecting this type before changing the Last Night manually will automatically set the Last Night to an appropriate date for monthly reservations, and optionally set the Blocked date to an appropriate date. For instance, it can reserve the site to the end of the year, or the end of next month, or make it a certain number of months long.

Owner -- This is essentially a "background" reservation. It's typically used to designate the owner or long-term lessor of a site who isn't always present. Even though the owner's name will appear on the Rack (unless "Show Owner reservations" is disabled on the Options), it won't block a site -- so other types of reservations can be made on top of the owner's reservation. For times when the owner is actually present, a separate "Normal" reservation should be made so the site is blocked, and to have a record of when the owner is present. There will be a special option on the right-click menu for owners, to make a reservation for the owner.

Hourly -- This is a special type for intra-day schedule reservations. For more information, see the Hourly / Scheduled Reservations section.

The New Reservation Dialog

A New Reservation dialog will be opened whenever you need to enter reservation details. (It's also used for assigning sites to existing reservations.) This dialog has entry fields for the basic reservation information, plus a miniature version of the Rack view. This miniature rack view can be used to select a site, and can be filtered by site type, site preferences, and available sites for the desired dates. As with the main Rack, it will show a red divider line to indicate the start of today, and it may also start with yesterday in the first column (depending on the Options settings).

Note: If a Default site type filter is defined for the Rack view, this filter will also be used as the default for this mini-rack view.

First and Last Night

The first thing to do is verify the first and last night of the stay. The first night and possibly even the last night may already be set, depending on how you started the reservation. (Tip -- if "Available Only" is selected on the Rack, both the first and last nights will default to the rack dates when double-click is used.) In this case, the mouse cursor will automatically be placed in the Nights field, with the number 1 highlighted. (To change the number of nights, all you need to do is type the new number, and the 1 will be replaced with the new number.) Otherwise, you will want to select the date for the First Night, and then either select the date for the Last Night or enter the number of nights -- when one of these two fields is changed, the other one automatically adjusts to match.

Another way to select the number of nights is with the "+1" buttons, which make it easy to add 1 day, week, or month to the reservation with mouse clicks. (Note: these buttons will not be available if Days of the Week are enabled, below). A special case exists with the +1W, +1M and +1Y buttons -- if they are used when the reservation is still just 1 night, they will make the reservation for exactly 1 week, 1 month or 1 year respectively, rather than actually "adding" 1 week or month. Thereafter, it will add weeks or months as needed. Also note that the +1M button may be replaced by a specific number of days instead of a calendar month, e.g. +30 days, depending on your settings in Program Options / Monthlies.

Important -- Remember that "Last Night" means exactly that -- the last night of their stay. It's not the check-out date, which is typically the following day (the next morning). This may take some getting used to if you've been going by check-out date.

Block To

In Campground Master, the "blocked" date is used to keep the site available for a customer to some date later than the official Last Night. For instance, if they say that they want to stay 3 days for sure but might want to stay 5 days (assuming availability is not an issue), you would typically make the reservation for 3 days (and charge for 3 days), and use the Block To date to block it to the 5th night. It won't try to charge them for the extra 2 days, but the site will be considered unavailable for other reservations for all 5 days (the blocked dates appear in a light grey on the Rack for easy identification). When they check out or decide to whether or not to extend their stay, then you can adjust the Last Night accordingly or remove the Block To date.

Note that Owner and Day Pass reservations cannot have a Blocked date.

First, Last, and Block Period

These fields will appear only if the reservation type is hourly / scheduled. For more information, refer to the Hourly/Scheduled Reservations section.

Days of the Week

If you have reservations that occur on certain days of the week, for instance if customers commonly reserve a site for every weekend for several months in a row, then you may want to enable the day-of-the-week fields for reservations (see Define Data Fields under the Maintenance menu). If these are enabled, then you will be able to select the specific days of the week to reserve, instead of making a separate reservation for every weekend.

If these are enabled, you will see a series of check boxes, with S, M, T, etc. above them. Just select which days to apply. Note that it may default to having none selected, which is the same as if all are selected so you don't need to select them all each time.

Note that if these fields are enabled, it will slow down some processes like updating the Rack view, so only use them if this is a common occurrence.

Reservation Type

The reservation type governs how the reservation is treated. The different types are covered in the previous section on Reservation Types.

Est. Arrival Time

If desired, you can enter an estimated arrival time for the reservation. This is helpful for knowing when to expect a customer to arrive, and is only used for your reference. This entry field is free-form so you can enter anything you like, but there is also a pick-list associated with it so you can simply select an option from the list if preferred (this helps keep entries uniform, but is not necessary for this field).

Finding A Suitable Site

If you don't want to assign a site at this time, or if you started by double-clicking on the rack so that a site is already selected, then you can skip to the Customer Information now.

If you know beforehand what site you will use, you can also use the Quick-Pick list to select a site -- just click on Quick-Pick Site, scroll the list if necessary, and select a site. It will automatically be used and shown in the mini-rack, and you can continue to the Customer Information.

Note: the Quick-Pick list will only show sites according to the site type filtering, as will the mini-rack. If you don't find the site you want, try resetting the site type selection to "All Site Types", or uncheck "Use Preferences".

Another way to jump a particular site quickly is by using the Search function -- **Alt-S** or **F9**. Just enter the site number or partial site name in the dialog that opens up, and the mini-rack will scroll down to that site immediately.

Showing Available Sites

If you need to find a suitable site for this reservation, you first need to verify that you have a vacancy for the nights selected. You can do this quickly by checking the box Show Available. Any sites with existing reservations for the selected nights will be eliminated from the mini-Rack view. (The specific sites filtered out follow the same rules as for the Available Only option on the Rack view -- see *Program Options and Settings* for details). If you find that you almost always check the Show Available box, you can save time by making this the default for new reservations. This setting is in the main menu under Maintenance / Program Options / Functions.

Note that if you're making an Owner-type reservation (select "Owner" in the Resv Type list), Show Available will also exclude owner-occupied sites. Otherwise, owner reservations are ignored so you can make normal reservations on the owned sites when the owner isn't present.

If you're familiar enough with your campground's sites to know which ones are suitable for the customer, you can immediately select one of the sites to use (see below) and move on. Otherwise, you may want to further filter the list by selecting a Site Type or Site Class from the drop-down list (both types and classes can be selected from the same list), or by clicking on [Site Preferences](#) to enter a detailed list of the customer's needs. Preferences include things like sewer, cable, rig length, waterfront, or any other attributes you have defined (see the *Maintenance* section for details on defining preferences).

'Hide Dirty Sites' checkbox

Only available if the Site Dirty field is enabled, this option can be used for walk-in reservations to hide any sites with the "Dirty" flag set.

Site Preferences

If you want to select a site by specific attributes, you can use the Site Preferences. The [Use](#) (or [Use Preferences](#)) box in front of the [More Pref's](#) button is checked by default, but in most cases the preferences selections are empty so this has no effect until you select preferences. The exception is when changing sites for an existing reservation -- any previous preferences selected will be used automatically. Any time you want to ignore the preferences, simply uncheck the [Use](#) box.

Up to 5 site preferences can be shown on the dialog as checkboxes (to the left of the mini-rack grid), to make the most selections easier. This is set up through Maintenance / Program Options. If preferences checkboxes are set up, simply check the desired preferences and only sites with those attributes will be shown (assuming the [Use](#) box is still checked). If the preference you need to select is not available as a checkbox, then you can click the [More Pref's](#) button to open the Site Preferences dialog.

The Site Preferences dialog shows a list of all attributes that a site can have. For each attribute, there are three possible selection methods -- a drop-down list, a value, or a Must Have/Must Not Have selection. Note first that any attribute which is blank (showing nothing next to the name) means that the customer doesn't care about that attribute, so it is not checked against the sites. The list should start with all blanks, unless you have already chosen a Site Type from the reservation dialog (that's actually one of the attributes).

If you select a value from one of the drop-down lists, for instance the Site Type, Site Class, Pad Type, or Site Facing, then you will be limiting the available sites to those that match that attribute exactly (this is one reason to define the pick lists for these attributes carefully).

If you enter a value for an 'attribute' field (for instance the Rig Length, Site Length, or Site Width), then any Site with that value or greater for the matching attribute will be shown. Note that entering the Rig Length on the New Reservation dialog is the same as entering it in the Site Preferences. In addition, some values can have both Minimum and Maximum values defined in the Site Attributes to define a range of allowed values, such as Rig Length, # Adults, and # Children. Therefore the values for these on the New Reservation dialog would need to meet both the Min and Max criteria of the site, or else the site would be excluded.

The other types of attributes, such as 50A, Phone, and Handicapped Access, can be either "Must Have" or "Must Not Have" (or blank). Note that when the attribute is blank there is a check box that's gray, meaning no selection. If you click it once, it will change to Must Have, and the box will be checked. If you click it again, it will change to Must Not Have, and the box will be white but unchecked. Finally, if you click on it a 3rd time, it will go back to the blank (gray) state.

After making your preference selections you can [Save](#) them, or if you change your mind you can click [Cancel](#) and none of the changes will be saved. Once they are saved, the mini-rack on the reservation dialog will remove any sites that don't fit the preferences criteria (preferences will filter the rack whether [Show Available](#) is checked or not, since [Show Available](#) only filters out sites with existing reservations).

Note that these preferences will stay with the reservation. They will show up on the reservation's Quick-Info window, and will appear in the Requests column of some of the tab views. Site preferences are especially useful when making unassigned reservations (a reservation with no site assignment), as a way to remember what attributes the customer asked for.

Selecting Sites

By now you should be able to see what sites are available for the selected dates on the mini-rack view. To select a site, just click on an empty cell in the rack for that site, and then click the [Add Selection\(s\)](#) button. Alternatively, you can simply double-click on an empty cell for that site, just like on the main Rack view, or right-click on the site and select [Assign Site](#). That site's cells for each of the reservation dates should immediately fill in, with the word **<new>** in red-on-yellow. The site abbreviation (left column) will also turn yellow so that you can easily locate the site(s) selected. You will also see the site name in the [Site\(s\) Selected](#) field.

If any of the dates conflict with other reservations, they will be shown with asterisks (***) in yellow-on-red. You won't be able to complete the reservation with conflicts, so you need to adjust the dates or pick a new site before continuing.

Here's a quick tip -- If you have not yet indicated a start date (for instance if you started from the Phone icon), you can select the date and site at the same time, similar to double-clicking on the Rack View. Just go straight to the mini-rack and select a site on the desired start date. In fact, you can select the entire date range right on the mini-rack -- drag the mouse to highlight all of the cells needed (e.g. 3 cells for 3 nights, starting on the appropriate night) and click [Add Selection\(s\)](#). The date range will change to the range of cells selected on the rack. Be careful with this, though, since any subsequent multi-date cell selection will change the dates again to the newly selected cell dates. Only single-cell selections will leave the dates alone once they are set.

Groups and Linked Reservations

If you're booking a group under a single name, or if you need to reserve an additional site for the same person (for example a trailer storage spot), you can reserve multiple sites at once. You can add additional sites to a reservation by selecting another site in the rack and clicking [Add Selections\(s\)](#) again, etc. Each site selected will show in the [Site\(s\) Selected](#) list, in addition to being shown as **<new>** on the rack. If you have a lot of sites to select, you can do it easily using **Ctrl**-click on each one (select multiple individual sites), or click on the first one and **Shift**-click on the last one to select a whole range of sites.

If you select the wrong site or sites and need to start over, use the [Clear All Sites](#) button to clear all selected sites. You can also select a single site to remove from the [Site\(s\) Added](#) list and click [Delete](#).

Multiple Site Clarification -- Although this is referred to as "adding additional sites to a reservation", remember that technically each reservation record can only have one site assigned to it. When you select more than one site, it will actually create multiple reservation records. Each of these reservations will be identical except for the site assignment, and they will be *linked* together and *synchronized*. This linked status will be tracked whenever you make other reservation changes or operations like checking in and out, so they can stay synchronized and act like a single reservation.

You'll see a [Linking...](#) button and possibly checkboxes for [Synchronize with](#) and [Sub-member of](#), which are used to select the way multiple reservations are linked together. For more information about linking modes and multiple-site reservations, refer to the [Groups and Linked Reservations](#) section.

Qty Entry Field

If this field is enabled, you can enter a number of sites to be automatically added. See the [Groups and Linked Reservations](#) section for details.

Checking Rates

Once you have a site and dates selected, you can use the Check Rates button to show the rate(s) available and calculate how much it would be. This is useful if they want to know the rate before making the reservation or giving you more information. If Auto-Rates are configured, then you can have it automatically apply the appropriate rates when the rates selection dialog is opened, so you get an instant total.

Don't Move

An extra preference you can set for the reservation, which is a reservation status rather than a site attribute, is the Don't Move option. If you want to make sure that this reservation is not moved to another site (e.g. to make room for someone else), check this box. This will be flagged as such and the Assign Site functions will be disabled for this reservation (unless of course the Don't Move option is manually unchecked again).

Customer Information

Once the site selection is taken care of, you're ready to either select a returning customer or enter the new customer information. No reservation can be made without at least a customer last name. (The minimum reservation has a first night, last night, and customer last name.)

Note: If there's already customer information when the dialog is opened (e.g. you're using this dialog to assign or change the site for a reservation, or add a new reservation for an existing customer), then all of the customer information fields will be disabled to prevent accidental changes to the customer.

Note that some of the information in the Customer area will come from (or become part of) the Customer record as well as stored with the Reservation record. This includes the Notes and the number of Adults, Children, Pets, Extra Vehicles and Extra Trailers. This apparent duplication is actually necessary so that it can be changed for each reservation they make (for instance, the number of children tends to change over time). When an existing customer is used, the information is automatically filled in from the customer's record. Any changes you make to the information (including the name, address, and phone) will be saved back to the customer's record, whether it's an existing customer or a new one.

Also note the Customer Details button. You can use this at any time, to enter or edit other customer information such as their vehicle information, driver's license, discount clubs, etc. You can also view their previous reservation history (for instance to see what sites they used before, or to verify an outstanding credit balance from a prior stay) and their transaction history. The amount of customer information you keep track of is up to you, but we believe that the more information you have the better prepared you will be to handle emergencies.

Automatic Zip/Postal Code Lookup

For U.S. and Canadian addresses, you can speed data entry by simply entering the Zip or Postal code in the City field. When you press **Tab** or **Enter** after the code, it will automatically fill in the City, State, Country and format-corrected Zip/Postal code for you. Note that there is no need to enter the spaces or capitalize the letters in Canadian codes, it will do that automatically. You can also use the Zip+4 format for U.S. codes if you like.

Returning Customers

If reserving for a returning customer that you have in the customer database, you don't have to enter the information again. You will use the [Find Customer](#) function to select an existing customer from the database.

There are two ways to do this...

The quickest way is to enter a portion of their last name in the [Last Name](#) field, then press **Tab** or **Enter**. (One letter is enough, but the more letters you enter the more direct match you will get). A small Select Customer dialog will appear (unless it's disabled in Maintenance / Program Options / Functions), listing any customers that match the last name entered so far. Simply select the customer from the list. (See the next section for details on using that dialog.)

If the above option is disabled (through Program Options), then you can still click the [Find Customer](#) button (or press **Alt-F**) after entering a portion of the last name. Any customers with last names starting with the letters you've already entered will be displayed.

In either case, after selecting a customer and clicking "Use", the customer's information will be copied to the New Reservation dialog, including any Notes, and the [How-found](#) field will be changed to "Return visit" automatically. If you selected the wrong customer by mistake, you can go back to Find Customer and select a new one (any changes made to the customer fields here in the meantime will **not** be saved).

The other method is to go straight to [Find Customer](#) without entering a portion of the name, and then search the list using the available options. There are various ways to search for customers (address, phone, first name, etc.), so this can be used even if you don't know their last name. For more information, see the section [Working with Customers](#).

Note that once a customer is selected, the Last Name field will be disabled -- this is a warning that the customer has been selected and any other changes you make (to the address, etc.) will affect that customer's information. If you made a mistake and need to select a different customer, use the Find function (which changes to "Find/Change Cust" once a customer has been selected).

It's important to know that the customer notes will be copied to the reservation's Notes field (and shown here for reference), but future changes to the customer's Notes or the reservation's Notes will not automatically be copied back and forth. This is so that you can keep specific notes for the customer that don't necessarily apply to the past reservations (e.g. "don't put next to the dump next time"), and likewise you can make notes to the reservation that don't stay with the customer (e.g. "canceled due to flood").

New Customers

If this is a new customer, simply enter the information you know. Starting with the Last Name, you can use Tab to jump to each field in a logical order. Note that the Address 1 and Address 2 are typically used for addresses that require additional lines, rather than 2 separate addresses. This would be important if you plan to print mailing labels, for instance. If you want to store a second address for the customer, you can use the Notes field.

Once you've entered some customer information, you can use the [Customer Details...](#) button to enter further details as explained above. It's a good idea to have their rig and vehicle information if you can get it, just in case you need it for authorities (e.g. to find them in an emergency, or if they are reported missing). You can also record their discount club information here for future reference.

Since you did not use [Find Customer](#), a new record will be created for this customer when you complete the reservation. However if you abort the reservation (with the [Cancel](#) button), the customer information you entered will **not** be saved. If you want to enter customer information without a reservation (such as entering your old customer records), you should use the [Customers / Add a New Customer](#) from the main menu, or [Customer Details](#) from the menu, or the Customers toolbar icon.

Check for Duplicates

This button will appear (below the Find Customer button) only if you have the option enabled in the settings (Maintenance / Program Options / Reservations / Duplicate Customer Checking), and only if a previous customer has not already been selected (through Find Customer, for instance). This will look for duplicates according to the criteria specified in the settings. If any are found with matching information, they will be shown in a list as Possible Duplicate Customers Found, where you will have the chance to decide for yourself whether it's really a duplicate and optionally use the previous customer instead of the information you just entered.

Notes

If you're changing the site for an existing reservation (or adding linked reservations), any previous reservation notes will appear here. If you selected an existing customer, that customer's notes will appear here, and will be copied to the reservation (if not changed). In any case, you can edit or add notes as needed. Notes will be shown as a single line here, but you can enter multiple line notes as long as you like by clicking the "..." button at the end of the notes entry field. This will open a separate Notes dialog for entering the notes. Any current notes will of course be shown, and the cursor placed at the end so you can begin entering notes immediately. When multi-line notes are displayed as a single line, for instance on the Detail dialogs or in lists, each line break will be shown as a double-backslash (" \\ ").

Finishing Up

At this point, you have several choices. If you're making a simple future reservation, you can click Done once you have a site selected or if you want it booked without an assigned site.

If you have more details to manage in the reservation, the Continue to Details button, which will close this dialog (saving the reservation the same as if Done was used) and open the Reservation Details dialog automatically. From there you can perform further actions -- Confirm or Guarantee the reservation, add charges or a deposit transaction, add guests to the reservation, etc.

Shortcuts to Guarantee, Check-in, etc...

To save a step or two, you can use some of the other options at the bottom instead of Done or Continue to Details. If you're ready to ask them for credit card information to guarantee the reservation, for instance, click the Guarantee button to save the reservation and go directly to the Guarantee function.

If it's a walk-in that you're ready to check in right now, you can use the Check In! button at the bottom of the dialog, which will take you straight to selecting the rate and/or entering transactions (assuming the options are set up to do so). Note that If no site has been selected, the button will be "Day Pass" instead of "Check In", since you can't check in reservations without a site assigned. See the section on Day Passes for more information on this.

If you're not checking them in at this time but want to go ahead and add charges or enter a deposit, then use the Charges & Payments button. This will save the reservation and go straight to the Transactions dialog, opening the rates selection so you can add charges immediately.

Inquiries / Pencil-Ins

If this is just an inquiry by a potential customer but you want to record the information for reporting purposes (or in case the customer calls back to make the reservation), click the Inquiry button. The information will be saved but it will not reserve the site. If they do call back to make the reservation, you can find them on the Non-Reserved tab view (or through the Find Reservations function), go to the Reservation Details dialog, and change the status from Inquiry to Pending (or Confirmed or Guaranteed).

The Inquiry status can also be used as to "**Pencil-in**" a reservation without considering it active in all respects. To do this, select a site for the reservation before clicking the Inquiry button. (Note: the option "Inquiry reservations with a site show on the Rack and block others" in Maintenance / Program Options / Functions must also be enabled). Now the reservation will be shown on the Rack and Map as if it's reserved, and will block the site as any other pending reservation. However it will not show on reports like Arrivals, Departures, On Site, etc. You can come back to the reservation later to either finish it up (change it to pending, etc.), or to cancel it. You could also use Continue to Details and/or change the status to Inquiry at any time to make it a pencil-in, but a site must be selected for it to show on the Rack or Map.

Waiting List / Can't Book

If the customer did want to stay but you could not find a suitable vacant site, then you should use either the Waiting List button or Cannot Book button, depending on whether the customer wants to be notified if something becomes available. It's recommended that you use one of these rather than just canceling the reservation without saving it, so that you have some useful statistics later on. Also, if they call back later and you do have an opening at that time, then you already have their information and can re-activate the reservation easily (see the Non-Reserved tab view).

Temporary Operator Override

If you're entering a reservation but you're unable to complete a function due to your Operator Access Level, you don't necessarily have to go all the way out to have a manager log in. Just right-click in the caption bar, and select "Temporary Operator Override". That will allow someone to log in for this function only -- after leaving this dialog, it will revert to the previous operator automatically.

The Select Customer Dialog

This dialog appears when entering new reservations, after entering something in the Last Name field and pressing **Tab** or **Enter**. (One letter is enough, but the more letters you enter the more direct match you will get). This dialog will show any customers that match the last name entered so far, and the first one will be highlighted. Pressing Enter will immediately use this customer, or you can use the arrow keys or the mouse to select a different customer to use.

Note: Customers with warning flags will be shown with a red background -- but if it's the currently selected customer, it will be in blue due to the selection highlight.

If no customers matched the initial search, a message will be shown instead of a list. From there you can press **Enter** (or click Add New) to open the Add New Customer dialog and enter the information, or just Cancel to go back to the New Reservation dialog and enter the information there.

Other options on the Select Customer dialog allow you to view (and edit) Customer Details for the currently selected customer, do a more advanced Find Customer (Find More), or add a new customer.

This dialog may be disabled if you prefer -- see Maintenance / Program Options / Functions.

Possible Duplicate Customers Found

If you have the Customer Duplicate Checking enabled, then you may see this dialog appear after entering a reservation for a new customer. This will show any previously entered customers that match the criteria selected in the settings (Maintenance / Program Options / Reservations / Duplicate Customer Checking).

Most customers fields are shown in the list so you can try to determine if it really is a duplicate (or you can View Customer Details to dig further, such as checking its reservation history). If any of the customers have the Warning flag set, they will be shown in red. You have three choices at this point:

Continue As-Is -- If you don't see one that's really a duplicate, click this button to keep the customer information you entered for the reservation (added as a new customer).

Use Selected Customer -- If you see one that's definitely the same customer, select that customer and click this button. Note that if you see some information that needs to be updates, you can also click View Customer Details to enter the changes first, Save that, then click this button to use the previous (and updated) customer.

Cancel the Reservation -- If you see that it's a customer entered before that you don't want to have as a guest again, here's your chance to just cancel the reservation without saving the information entered.

Note that if you choose to use a selected customer or cancel the reservation, you will be prompted for whether or not to abandon/delete the customer information you entered. Most likely you want to answer Yes, to avoid having the duplicate in the system.

Checking In

You can check in a reservation from the right-click menu on the tab views, or from the Reservation Details dialog by clicking on the Checked In check box. If it's a walk-in reservation, you can also select Check In directly from the New Reservation dialog.

A checked-in reservation is treated differently in many ways, most of which were already covered in the *Dynamic Interactive Reports* section.

One thing to note about color coding for a checked-in reservation is that once it's checked in, other status flags can affect its color so that a checked-in reservation can appear in several different colors. The most important one is whether it's paid or not -- the text will be red on the Rack for any dates that have not been paid for. (Like other colors, this can be changed through the Color Key). Also, a different background color will be used for Monthly, Group, and Free Stay reservation types once they are checked in.

Normally you will be checking in a reservation with today as the First Night date. If the reservation's First Night is not today, a warning message will give you the choice of aborting the check-in, checking it in and changing it to start today, or checking it in with the original start date. Be careful how you answer this, or you could change the start date by accident and then have to change it back to what it was (if you remember what it was!) These warnings typically happen when initially entering reservations for people that are already here when you start using the software, and later if you forget to check someone in and do it on a later date. However if someone arrives earlier or later than their planned reservation, you will get this warning if you don't change their start date before checking them in. (Actually it's a nice feature to have the software offer to change the date automatically, which saves a step -- just be sure to read the warnings carefully.)

If you do change the start date of the reservation (as a result of the prompt mentioned above), you will also be asked if they will be staying the same number of nights. If you answer No, the reservation's original Last Night will remain the same. If you answer Yes, then the Last Night will be adjusted automatically to make the number of days the same. If you find this prompt more of a burden than a help (i.e. if you nearly always answer No), then you can turn it off in Maintenance / Program Options / Prompts.

Now, once you've confirmed that you want to check in the reservation, the Transactions dialog will appear so you can enter charges, payment, etc. and print a receipt. Note that if you click Cancel on the Transactions dialog, it does not cancel the check-in, only the transactions. In addition, you can have it jump immediately to Select Rate(s), where you can immediately select the appropriate rate from a list. These are both options that can be disabled -- if you prefer not to see the Transactions dialog automatically every time you do a check in, or don't want to select the rate immediately, you can turn these functions off in Maintenance / Program Options / Prompts.

If you checked in a reservation by mistake and want to undo the check-in, go to the Reservation Details dialog and click the Checked In check box, then confirm the undo. Manager access is required for this function.

Note that there is an option to show a warning if the previous reservation has not been checked out before checking in the next one. You can also prohibit checking in before the previous has been checked out, by Access Level. See Maintenance / Program Options / Prompts for more information.

Checking Out

You can check out a reservation from the right-click menu on the tab views, or from the Reservation Details dialog by clicking on the Checked Out check box. A checked-out reservation is treated differently in several ways, most of which were already covered in the *Dynamic Interactive Reports* section. On the tab views, a checked-out reservation is always the same color, typically a dark gray. There's also a Program Option to hide checked-out reservations completely, making the site available again (e.g. in case of early check-outs).

Normally you will check out a reservation on the day after its Last Night, since they would leave that morning. If this is the case, you will notice that the right-click menu on the tab views will show "Check Out (this morning)" instead of just "Check Out". That's a clue that the current Last Night will automatically be assumed when you perform the check out. If this is not correct, you will need to adjust the Last Night to be correct first, and then check them out. Note that this assumption is also true if checking out from the Reservation Details dialog, but there is no "this morning" indication -- it's up to you to verify that the Last Night is correct.

If the Last Night is not yesterday, you will get a warning that they are not scheduled to leave yet, or that they were scheduled to leave earlier. If their Last Night is in the future, your only options are to cancel the check-out (presumably because it was a mistake) or make yesterday their last night. In other words, you can't actually say that they left in the future. However if their Last Night is in the past, you are given the choices similar to Check In -- abort, check out with yesterday's date, or check out without changing the Last Night. Therefore if you forget to check out some old reservations, you can do it later and not affect their departure date. Of course if they really are just leaving, you can have it automatically change the Last Night to reflect that. As with the Check In function, it's a good idea to read all warnings carefully.

Now, once you've confirmed the check-out, the Transaction dialog will appear. (This is an option that can be disabled -- if you prefer not to see the Transactions dialog automatically every time you do a check in, you can turn it off in Maintenance / Program Options / Prompts.) You can verify that their balance has been paid and make adjustments or payments as needed, and print out a new receipt if they need one.

(You also have the chance to adjust the Last Night, just in case none of the previous choices were quite correct.)

If you check out a reservation by mistake (or if they change their mind and come back the same day), you can undo the check-out through the Reservation Details dialog. Just click on the Checked Out box and confirm the prompt. (You can then go into Transactions and make additions, etc.) Manager access is required for this function.

Auto-Checkout today's departures (Bulk Checkout)

This function can be found on the right-click menu of the Departures tab view. Selecting this option will check out all reservations currently checked in with a last night equal to yesterday's date (i.e. departing today), provided that their Paid-thru Date is set to their Last Night and they have a \$0 reservation balance. If the reservation has any Guest reservations, they must also have a \$0 balance and be due out today or earlier, and the Guests will be automatically checked out also.

Transactions

The section *Working with Transactions* covers transactions in depth, so this section will just cover the basics of how transactions can be entered for reservations.

Any time a function is performed on a reservation that might result in additional charges or payments, the Transactions Dialog will be used to enter new transactions. It also shows previous transactions for review or editing. The other function of this dialog is to print or E-mail a receipt (or other forms such as confirmations, Window Tags, etc).

Getting to the Reservation Transactions Dialog

The first step to entering transactions is getting to the Reservation Transactions dialog. There are several ways to do this, listed below. You should get familiar with all of them, since this is one of the most common functions used, so getting to it efficiently is important. Note that in some cases it's opened for you automatically, for instance when checking in a reservation, or checking out a reservation with a balance due (depending on the Options). Most other times you need to open it yourself.

New Reservation, "Charges & Payments" button -- If you're making a new reservation, clicking the "Charges & Payments" button on the New Reservation Dialog will take you directly to Reservation Transactions. This is a handy shortcut, especially if you don't need to make other changes to the Reservation Details or send a confirmation. Whether you use this button or "Continue to Details" or "Guarantee" (see below) depends on what else your normal procedure requires.

New Reservation, "Guarantee" button and then "Enter a Deposit Transaction Now" -- If you are making an advance reservation and need to enter a deposit, this sequence may be best for you to enter a deposit to guarantee the reservation. It will not only open Transactions, but will immediately open the Enter Deposit dialog.

Right-click menu from the Rack -- Most of the time you will likely be viewing the Rack, where you can see an overview of reservations for the next month or so. So this is one of the quickest ways to get to Transactions (and many other functions) for current and upcoming reservations. Just locate the reservation on the Rack, right-click on the name, and select "Transactions" from the menu that pops up.

Right-click menu from the Map -- You can right-click directly on the Site number on the Map, assuming it has a current reservation (as of the "From" date selected at the top), and select "Transactions" from the pop-up menu.

Right-click on other Tab Views (Arrivals, Departures, On Site, etc) -- As with the Rack, you can right-click the customer name on any of the Tab Views showing reservations to open Reservation Transactions.

Right-click on the Transactions tab -- The Transactions tab view is used for both summary reports and detailed transaction reporting. When in Details mode, it becomes a powerful tool for finding transactions already entered and researching issues. Once in Details mode, you can right-click on each transaction and get the familiar menu, where you can select "Transactions" to open the appropriate Transactions dialog where you can see the full details. The important thing to note here is that it will open the **appropriate** Transactions dialog -- that is, if the transaction belongs to a Reservation, it will open the Reservation Transactions dialog. If it was entered only on a Customer, not a Reservation, then it will open Customer Transactions. If it was

entered as Unbound or in Point of Sale (with no customer or reservation selected), then it will open that appropriate dialog, and so on. So using this method is also a good way to find out exactly how the transaction was entered.

Reservation Details, "New/Edit Transactions" button -- If you're already in Reservation Details, just click the New/Edit Transactions button. Of course there many ways to get to Reservation Details, covered elsewhere, but the point here is that if you're *already* in Reservation Details, then you're just one step away from Transactions. **IMPORTANT** -- do *not* use New/Edit Transactions from Customer Details, since that will not associate the transactions entered with any particular reservation, because one Customer can have many Reservations (see *Database Organization*). Except for very specific cases that are unrelated to a specific reservation, such as membership dues, you will not want to enter transactions directly on Customers.

Reservation Details, "Quote/Confirmation" button -- This is also on Reservation Details, but has a special use. While the dialog it opens is identical to Reservation Transactions, it's only used for temporarily entering transactions, e.g. for confirmation letters, in which case you don't want to save the transactions as real balances due yet. This is covered more in the *Working with Transactions* chapter.

Transactions menu -- We consider this the "last resort" way to get to Reservation transactions, since there are so many quicker and less error-prone ways, at least for near-term reservations. Selecting "Enter Reservation Transactions" from here will open a Find Reservation dialog. You will need to enter the customer name and/or other information to locate the reservation of interest, and then select the desired reservation from the list (double-click on it is quickest, or select the line and click "Use"). There are 2 big reasons we consider this an error-prone method and should only be used if necessary -- It's easy to select the wrong transaction from the list and end up entering them on the wrong transaction (e.g. for the same customer or even a different one), but worse yet you may accidentally select "Enter Customer Transactions" instead, so it would take you to the wrong place (same as entering from New/Edit Transactions on Customer Details -- see the warning above).

Ctrl-T shortcut -- This keyboard shortcut will open the most recently used Reservation Transactions (it must be used from the main screen -- with no other dialogs open). So if you need to go back to the ones you were just looking at, this is a quick way to do it. Note that you can also use "Edit the Last Transaction Viewed" from the Transactions menu, if you forget what the shortcut is.

Entering the Transactions

Once you get to Reservation Transactions, you will see any previous transactions that reservation has -- Campground Master will always keep a continuous list of transactions for a given reservation -- it's a running tally as well as a history.

If you take Advance Deposits for future stays, that should be the only thing you enter until they arrive. See the section on Recommended Transaction handling for more information, before you start entering Charge transactions.

Typically once they are checked in, you will enter any Charges (as well as discounts and taxes) to the Reservation, e.g. the rent for their stay. There are 4 primary ways to add Charges:

"Select Rates" button -- Assuming you have Rates set up, you can use this to select the appropriate charges from a list of pre-defined Rates. This is probably the most commonly used function for adding transactions, if you don't have it set up for Auto-Rates (which can be complicated).

Auto-Rates, Automatic addition -- If you have "Automatically add auto-charges" enabled for Auto-Rates (and working correctly), then you may see those already on the reservation. Any transactions added by Auto-Rates will have a blue background, to distinguish those from manually-entered transactions. See Auto-Rates for more details.

Auto-Rates, "Auto-calculate" button -- With Auto-Rates enabled, there will be a button to "Auto-calculate Rate Charges" on the Reservation Transactions dialog. When this is clicked, it will use the Auto-Rates

functionality to immediately add the calculated charges, or re-calculate if there were already auto-charges added. This is typically used when initially testing the auto-rates setup, or to recalculate after reservation changes. It can also be used for long-term reservations to add another month's charges, for instance.

Manual entry buttons -- If you don't have appropriate Rates set up yet, or need to enter special charges, then you can use the individual transaction buttons -- Charge, Discount, and Tax.

Metered electric, water, or gas -- If you're set up for calculating the charges for metered electric, etc, then you can use Select Rates to enter an individual meter reading, or if you do batch readings then you would enter those through the Meter Reports instead of through the Transactions dialog.

Once you have the charges entered, you will need to enter any Payments. The only way to do that is with the manual "Payment" button. Likewise, you may enter Credits, Refunds, etc. with the appropriate button. See those sections for details.

Printing a Receipt, etc

The Transactions dialog is also where you will print receipts, invoices, confirmation letters, and other forms. You can print receipts at any time, whether you have entered new transactions or not. This is handled with one of the buttons in the lower left corner of the dialog.

You should first select the Receipt Type, if the default (shown above the Print buttons) is not appropriate. The default will be the type selected in File / Printing Options, and the "Ticket form" is the initial default. Just select the desired type in the drop-down list to change the style that prints, before clicking one of the Print buttons (this will not change the default for next time). For details on the different formats, see the *Receipt Types* section.

Once the receipt type is selected, you can print the receipt. There are two choices for printing:

Print Reservation Receipt (All) will print a receipt with all of the transactions shown, old and new.

Print Only Some Transactions will print the same kind of receipt but with only certain transactions. There are several options for what to print, selected next to the button (before clicking the button) -- see *Printing Receipts* in *Working with Transactions* for details.

E-mailing a confirmation or receipt

This is similar to printing, but instead you will just click the "Send E-mail form..." button at the bottom of the Transactions dialog. That will take you to another dialog which allows you to select which E-mail form to send, which transactions to include, etc. See the "E-mailing receipts" section for more details.

Linked and Group Reservations

Overview

Group reservations and other linked reservations can be created easily, which can save time maintaining reservations for multiple sites.

Clarification -- although they are often referred to as "group reservations", remember that technically each reservation record can only have one site assigned to it. When more than one site is linked, or in a group, it's actually multiple reservation records with internal links between them. This allows them to be handled in certain ways as a single reservation.

Linking Overview

Reservation linking is handled through a system called "Portfolios". This is mostly an internal organization term -- as a user, you see the linkage as a tree structure similar to file folders on the computer. Any reservation can own any number of portfolios (folders), each of which can contain any number of reservations -- which can in turn own other portfolios. Technically there is no limitation to the number of levels or complication of the structure, but in practice you're likely to only use 1 or 2 levels.

In addition to the multi-level linkage structure, each portfolio (set of reservations) can be one of 3 types. Note the distinctions between these types -- it's important to know which type to use for different situations:

- **Synchronized** -- The reservations keep their dates and status in sync automatically (for instance when you check in one, the rest are all checked in automatically), and are combined for billing purposes. They must all be under the same customer name.
- **Non-synchronized** -- Reservations linked this way can have different dates and have separate transactions for billing. They start out under the same customer name, but the customer for each one can be changed later through the "Change to a different Customer" function in Reservation Details.
- **Sub-member** -- Besides being "logically" a sub-member of the owner reservation, transactions (billing) will be combined with the "transaction master" reservation and the customer must be the same. However, it's not synchronized with the portfolio owner so the dates do not have to be the same as the owner reservation.

Some important points:

- All synchronized and sub-member reservations are combined for billing (and any synchronized or sub-members of those, etc. all combined with their top-level owner). However, non-synchronized reservations are considered separate "sets" or "top-level reservations" for billing. Thus by using appropriate link types, you can completely control which reservations are combined for billing.
- Only synchronized reservations will maintain identical dates and status. But changes to any linked as sub-member or non-synchronized will only affect that particular reservation.
- There are no date restrictions for sub-members (for instance it's not like a Guest reservation where the guest's stay can't be outside the host) -- so by using sub-member linking it's even possible to combine billing for separate stays (even on the same site!) for the same customer.
- Even Guest reservations can have sub-member reservations linked to it -- so for instance a Guest can rent a stall or canoe, which can be combined on the guest's bill and not affect the host reservation.

- If the dates and/or the customer of any linked reservation is different than the master reservation, then the differences will be noted wherever the tree list is shown.
- If you need different customer names on each reservation, e.g. for groups, then they must be non-synchronized.

Transactions and Auto-Rates

A single collection of linked reservations can contain some that are billed separately and some combined, and even the combined ones can have different dates. This requires some special handling of the transactions for linked reservations. See *Working with Transactions / Reservation Transactions* section for more information.

Linked Reservation Examples

Most of the time you will probably just use the basic linking methods, either making a group of Synchronized or Non-Synchronized reservations, or using Sub-member to split a reservation among different sites/dates. Here are a few simple examples.

Synchronized Group creation (in New Reservation)

The assumption is that this is multiple sites rented by one person/entity, paid all at once, and they will all arrive and leave on the same dates. There is no need to record individual names, etc. on each site.

Start by creating the reservation for the first site & dates, but stay in the New Reservation dialog. Enter the customer information, etc. as needed. So at this point you have everything ready to finish for one site (showing "<NEW>" in the grid) and would normally click Done or one of the options at the bottom to continue to the next step. Instead, we want to add more sites:

1. Make sure the "Synchronize with" box is checked.
2. Add the next site (for instance use Quick-Pick or double-click in the grid as usual). The new site will also show "<NEW>" in the grid, and it will be added to the "Site(s) added" list.
3. Repeat steps 1 and 2 to add as many sites as needed (don't forget to check "Sub-Synchronize with" each time).
4. Optionally select "Group" for the Resv Type.
5. Click Done or one of the other options to continue to the next step, and proceed as usual.

That's all there is to it.

Adding More Synchronized Sites

Let's say you need to add more sites (or forgot to stay in New Reservation to add the other sites). It's easy to add more to the first reservation.

1. Go to Reservation Details for the first reservation.
2. Optionally select "Group" for the Resv Type (this must be done in Reservation Details since the reservation is already completed).
3. Click the "Add Sync'ed..." button.
4. Proceed as above for Synchronized Group, starting on step 1, just as if you never left New Reservation.

You can also use the right-click menu from most tab views to replace steps 1 and 3 -- right-click on the reservation of interest, select Linked Reservations, and then select Add Synchronized Reservations.

Non-Synchronized Group creation (in New Reservation)

The assumption here is that this is multiple sites rented by different people, so they all need separate billing (or you want them all to show separate Customer information). They may have different dates or other settings, but you want to start them all with the same dates to make it easy.

Start by creating the reservation for the first site & dates, but stay in the New Reservation dialog. Enter the first customer information, etc. as needed. So at this point you have everything ready to finish for one site (showing "<NEW>" in the grid) and would normally click Done or one of the options at the bottom to continue to the next step. Instead, we want to add more sites:

1. Uncheck both "Synchronize with" and "Sub-member of".
2. Add the next site (for instance use Quick-Pick or double-click in the grid as usual). The new site will also show "<NEW>" in the grid, and it will be added to the "Site(s) added" list.
3. Uncheck both "Synchronize with" and "Sub-member of" again, and then select the next site.
4. Repeat step 4 as many times as needed to add more sites. Don't forget to uncheck the linking options **before** each site is added.
5. Optionally select "Group" for the Resv Type.
6. Click Done or one of the other options to continue to the next step.
7. If they're making a single Deposit payment to be split among all of the sites, you can do that (see the note "Splitting the deposit among multiple reservations" in Payments and Deposits).

Now you have a group of non-synchronized reservations, but they're still all under the same name and same dates, etc. At some point you'll want to change the customer for each one, perhaps change the dates, change the number of people on each site, etc. To do this you would simply go to Reservation Details for that particular reservation and make the necessary changes. If changing the Customer, make sure you follow the correct "Changing to a different customer" procedures -- do **not** just go to Customer Details!

Adding more Non-Synchronized Sites.

The procedure for this is basically the same as for Adding Synchronized sites (above) -- just use "Add Non-sync'ed" instead of "Add Sync'ed" (or in the right-click menu, select Add Non-Synchronized Reservations).

Sub-member Set creation (in New Reservation)

The assumption is that this is multiple reservations for one person/entity, paid all at once, but they are for different dates -- or it may even be the same site each time but on different dates.

Note: This is also a good way to make a reservation that has to move in the middle of their stay (e.g. due to site conflicts). However, it's recommended that the last part of the reservation (e.g. the latest dates) be made first. That way the last part of the reservation is "active" until they leave. Also see Splitting Reservations, which handles splitting the reservation after it's created.

Start by creating the reservation for the first site & dates, but stay in the New Reservation dialog. Enter the customer information, etc. as needed. So at this point you have everything ready to finish for one site (showing "<NEW>" in the grid) and would normally click Done or one of the options at the bottom to continue to the next step. Instead, we want to add more sites:

1. Make sure the "Sub-member of" box is checked.
2. Select the First Night and Last Night for the 2nd reservation.
3. Add the site for the 2nd reservation (for instance use Quick-Pick or double-click in the grid as usual). The new site will also show "<NEW>" in the grid, and it will be shown in the "Site(s) added" list.
4. Repeat steps 1 to 3 to adding as many sites as needed (don't forget to check "Sub-member of" each time).
5. Optionally select "Group" for the Resv Type.
6. Click Done or one of the other options to continue to the next step, and proceed as usual.

Adding More Sub-member Sites

The procedure for adding sub-members *below* an existing reservation is basically the same as for Adding Synchronized sites (above) -- just use "Add Sub" instead of "Add Sync'ed" (or in the right-click menu, select Add Sub-member Reservations).

Inserting a new reservation as a top-level "Linked Master" (version 11.0 or later)

Sometimes you want to make a new reservation linked to an existing one, but instead of making the new one a sub-member of the existing one, you want to reverse them so the new reservation is the Linked Master and the existing reservation is the sub-member. The most common use for this is when someone needs to extend their stay but has to move to another site for the 2nd part, but there's no room to make the reservation long enough initially to perform the normal Split function. Rather than make the "new" reservation the sub-member, it's best to make the old part be the sub-member -- this is recommended so that the latest part shows as the main site on receipts and carries the transactions, since it will be checked out later than the old part.

In prior versions this was very difficult, requiring a lot of manipulation of dates and sites. A new function was added in version 11.0 to make this simple:

1. Locate the existing reservation on the Rack (or On Site, etc).
2. Right-click on it, select Linked Reservations, and then Add a New Linked Master reservation (making this its Sub-member).
3. The standard "New Reservation" dialog will open -- select the dates and then select the site for the new reservation as usual, and click Done.

The new reservation is created as the linked master, and the old one is a sub-member of the new one. Note that any transactions that were on the original reservation will be moved to the new reservation automatically, and if you're using Auto-Rates then it may recalculate as needed to add the charges for the new reservation.

Managing Existing Reservation Linking

The Linked Reservation Examples in the previous section all dealt with adding new reservations and linking them as they are added. This section covers linking and unlinking reservations that have already been made, or changing the type of linkage.

Changing the linking method

Sometimes the linking method is changed for you (after a prompt to confirm it) -- for instance if you change the dates on a reservation that has others synchronized with it, they you will be asked if you want to change the dates of the synchronized ones also. If you answer 'No', then it must make them sub-members. Likewise if you change the Customer when linked as a synchronized or sub-member, then if the others aren't changed also then they can only be linked as non-synchronized.

You can also make changes manually if needed. This is done by right-clicking on the reservation of interest on the Rack or other tab view. Note that you must select the 'child' reservation of interest, since the action will change how *that* reservation is linked to its 'parent'. In the right-click menu, go to Linked Reservations, and then select the appropriate "Make this a ... reservation" option, e.g. Make this a Sub-member reservation.

There are some restrictions, depending on the situation:

- Both Synchronized and Sub-member links can be changed to Non-Synchronized.

- Only Sub-members can be changed to Synchronized, and only if they have the same dates. Some other fields must also be equal also (e.g. the Status), but if those are different then you will be prompted to change the child's fields to match the parent before changing it to Synchronized. (In order to change a Non-synchronized to synchronized, change it to a Sub-member first, then to Synchronized.)
- Any Synchronized link can be changed to a Sub-member.
- A Non-synchronized link can only be changed to a Sub-member if it's under the same Customer.

Important: When you change the link type, it may also change where transactions go. For instance, if you change a Non-synchronized reservation to a Sub-member, any transactions that were on that reservation must be moved to the linked master (which will be done automatically).

Linking existing reservations (version 11.0 or later)

If you have reservations that were created separately and now want to link them together, e.g. for combined billing, then that's possible starting in version 11.0. (Prior to v11, there was no way to link existing reservations.)

This is done by right-clicking on the reservation of interest on the Rack or other tab view. Note that you must start by selecting the reservation that you want to be made a 'child' of another reservation -- i.e. how you want it to be 'linked to' another reservation. In the right-click menu, go to Linked Reservations, and then select the appropriate "Link this reservation to another..." option, e.g. Link this reservation to another, as Sub-member.

Note that you can only do this with 'top-level' reservations, e.g. reservations that are not already linked as children to another reservation. It can have children of its own, which it will still have after linking, so you can build a new 'tree' from the bottom up if needed.

You will then be shown a list of possible 'parent' reservations for this reservation to link to, if any exist. For instance if you're linking as a Sub-member, it will only show ones for the same customer. For Synchronized, they must have the same dates. For Non-Synchronized, the normal "Find Reservation" dialog is used, since they can have any customer, but it will start by showing the customers with the same last name.

Select the desired reservation to link to, and click "Link to the selected reservation" (or in the case of Non-synchronized, just click "Use").

Important: When you link reservations as Sub-member or Synchronized, it will change where transactions go. Any transactions that were on the reservation (now linked as a child) must be moved to the new linked master (which will be done automatically).

Unlinking reservations (version 11.0 or later)

While changing the linking method to Non-synchronized separates reservations functionally (separate billing, changes, etc), you may need to completely unlink it -- for example, so you can link it to a different reservation. In versions prior to 11, the only way to unlink a reservation was to Cancel it, which forced an unlink.

This can now be done by right-clicking on the reservation of interest on the Rack or other tab view. In the right-click menu, go to Linked Reservations, and then select the appropriate "Unlink ..." option:

Unlink this reservation from its parent (keeping any 'children' linked to it) -- this will simply "prune" the reservation from whatever link tree it was part of -- unlinking it from its parent, but keeping any others linked directly to it as children.

Unlink this reservation from all others -- this will make it a completely separate reservation, no longer linked to anyone. If it had any children linked to it, those will be linked to the previous parent of this reservation, moving them "up the tree".

Note that this action may result in a change in where transactions for this reservation must go -- e.g. it will now be a "linked master" (or individual) reservation, so it must have the transactions for it. If it was previously a Synchronized or Sub-member reservation, then its previous linked master should have the transactions for this site removed.

Viewing Linked Reservations

When showing a list of linked reservations in Reservation Details or the Quick-info window, a tree-structure list is used to indicate the portfolio levels and also the type of linkage for each reservation. These symbols are used to indicate the link relationship with the owner reservation (the portfolio type):

- = **Synchronized**
- # **Non-synchronized**
- > **Sub-member**

Note that in the tree structure, the top-level reservation won't have an indicator, because it's not a member of any higher portfolio. This top-level reservation is considered the "Master" of the linked reservations.

In some cases, an asterisk (*) will be shown in front of one of the reservations. This simply indicates which one you're currently viewing.

Here is an example diagram of a fairly complex set of linked reservations, as it would appear in the drop-down list on Reservation Details or on the Quick-info window:

```
RV 1 [Linked master]
  = RV 2 [synchronized with RV 1]
    > Stall 1 [sub-member of RV 2]
  = RV 3 [synchronized with RV 1]
  # RV 4 [not synchronized]
    > Boat slip 1 [sub-member of RV 4]
    > Kayak 1 [sub-member of RV 4]
  # RV 5 [not synchronized]
```

This looks confusing at first, but it will make sense once you learn the symbols and notice the spacing to indicate levels/ownership. Also note that the relationships are clearly detailed in case it's not obvious from the structure. There's a step-by-step example of creating these reservations in the "Creating Linked Reservations" section that follows.

In portfolio terms, there are 4 portfolios involved:

- RV 1 owns 2 portfolios -- a Synchronized portfolio containing RV 2 and RV 3, and a non-synchronized portfolio containing RV 4 and RV 5.
- RV 2 owns 1 portfolio -- a Sub-member portfolio containing Stall 1
- RV 4 owns 1 portfolio -- a Sub-member portfolio containing Boat slip 1 and Kayak 1

However, you can pretty much forget about "portfolios" now. While that's the way it's stored and managed internally, the only thing you're concerned with is their "link relationships", which are already detailed in the tree-structured list.

A couple important notes about this example:

- Since all synchronized and sub-member reservations are combined for billing (and any synchronized or sub-members of those, etc. all combined with their top-level owner), the reservation for RV 1 will also contain all transactions for RV 2, RV 3, and Stall 1. However, non-synchronized reservations are considered separate "sets" or "top-level reservations" for billing -- so the reservation for RV 4 will include transactions for Boat slip 1 and Kayak 1, and RV 5 will only contain transactions for itself. Thus by using appropriate link types, you can completely control which reservations are combined for billing.
- Only synchronized reservations will maintain identical dates and status. Thus RV 1, 2, and 3 will stay synchronized if a change is made (assuming the appropriate answers are given when prompted to keep them synchronized). But changes to any of the others will only affect that reservation.

Creating Linked Reservations - Details

You can create any number of linked reservations directly in the New Reservation dialog, which allows quick and flexible linking when creating reservations. The default "Linking Mode" is mixed-mode, but other options are available if you need to quickly create reservations all linked the same way.

Note: If you're new to Linked Reservations, be sure to read the preceding Overview and Linked Reservation Examples sections first to get the basics. This section is much more detailed and advanced than most people need.

Link Mode -- the "Linking" button

The New Reservation dialog has a "**Linking...**" button below the grid. This allows you to change the linking mode for the sites (reservations) being added in the current session, and also allows you to set one of the modes as the default linking mode for all new reservations. When you click the Linking button, a dialog will appear with the linking choices:

Mixed linking modes -- this allows the most flexibility but isn't always the quickest. See below for a full explanation of using this mode.

All Synchronized -- This is used if you want all sites selected to be linked as synchronized reservations -- all dates, etc. will be the same.

All Sub-members -- This will make all reservations sub-members of the first one, so that the billing is combined but the dates could be different (and each reservation needs to be checked in and out separately).

All Non-synchronized -- This will create non-synchronized reservations for the sites, so billing is separate. While they will all be made for the same customer initially, you can easily change the customer for each one later.

Not linked at all -- This will create multiple reservations for the same customer, but they will not be linked at all. The customer for each one can be changed later if necessary.

There's also a "Save" checkbox at the bottom that you can check to make this new linking mode the default each time you enter the New Reservation dialog.

Note that when the linking mode is All non-synchronized, All sub-members, or Not linked at all, then when adding sites you can either let them all be made on the same dates or you can change the dates for each one. As you add sites, each new one will be "selected" in the Sites Added list. Any changes you make to the First and Last dates (or periods), ETA, or "Don't Move" option will affect only that site (and will be the default for the next site added). So to add sites with different dates be sure to add the site first, then change the dates. This

is different than in Mixed mode, where you would have to uncheck "Synchronize with", change the dates, then add the site.

Mixed Mode Linking

This is the default mode and allows flexibility, so we recommend leaving it in this mode unless you do mostly large groups that need to be non-synchronized.

In this mode, there will be two check-boxes next to the Add Selection(s) button. For a single site/reservation, they have no affect. However once a site is added, the checks in these boxes determine how a subsequent reservation is linked to the previous one (or to be specific, how it's linked to the reservation currently selected in the Site(s) added list).

Also note that the Site(s) Added list is a drop-down box, not just text. This allows you to view the currently added sites/reservations regardless of how many there are, and it will be a tree structure with indicators as described above. Additionally, you can select any single site and use the Delete button to remove just that site from the list (or use Clear All as before). Most importantly, you can select any site in the list after adding it to change its dates, preferences, etc. and add linked sites to it (e.g. sub-members). This allows a complete structure to be created as in the example above, all while in the New Reservation dialog.

The "Synchronize with" box is checked by default, which means all sites will automatically be synchronized if you add multiple sites using Quick Pick or double-clicking on the grid. (For convenience, the synchronized sites are also listed in the same line as the owner so you don't have to drop down the list to see the first few synchronized sites).

To make a Sub-member reservation, make sure the desired "owner" reservation is selected in the Site(s) Added list, check the "Sub-member of" box, and adjust the dates if needed. Then add the site you want to be a sub-member (using Quick-Pick, double-click, or the Add Selection(s) button after selecting a site in the grid).

To make a Non-synchronized site (for separate billing), uncheck both of the boxes (so it's not synchronized or a sub-member), and then add the site as above.

Important: Any time the "Synchronize with:" box is checked, any changes to the dates, reservation type, or preferences will affect the currently selected (shown) site in Site(s) Added, and of course any of those synchronized with it. Thus it's a method to alter sites already added, but you also need to be careful to avoid altering a site when you didn't mean to.

Once all of the sites have been added as needed, save the reservation as usual and all of the appropriately linked reservations will be created. Note that if you use buttons like "Check In" or "Guarantee", this will only affect the top-level reservation or any synchronized with it. Sub-members and non-synchronized reservations will remain as Pending since their status does not stay synchronized with their owners.

Example: To create the reservation structure illustrated earlier, you would follow these steps after entering New Reservation:

1. Select the dates desired for RV 1 (and 2 and 3)
2. Add RV 1
3. Add RV 2 (note that "Synchronize with:" is already checked)
4. Add RV 3
5. Uncheck "Synchronize with" (prepare to add non-synchronized reservations, linked to RV 1, which is still selected)
6. Change the dates if needed for RV 4 (note that you must uncheck "Synchronize with" *before* changing dates, or else it would affect the RV 1/2/3 sites)
7. Add RV 4 (note that RV 4 will now be selected in the Site(s) Added list)
8. Uncheck "Synchronize with" again (it's automatically checked each time you add a site, so subsequent synchronized sites can be added easily -- but we don't want that)

9. Add RV 5 (RV 5 will now be selected in the list) Also note that it added RV 5 as a non-synchronized site with RV 1 as the owner, even though RV 4 was selected. Since there's no reason to have multiple levels of non-synchronized sites, it simplifies the structure automatically. The same would be true of Synchronized sites added to each other.
10. Select RV 2 in the Site(s) Added list
11. Check "Sub-member of" (prepare to add the Stall 1 to RV 2)
12. Change the dates if needed
13. Add Stall 1
14. Select RV 4 in the Site(s) Added list
15. Check "Sub-member of" (prepare to add the boat slip and kayak to RV 4)
16. Change dates if necessary
17. Add Boat slip 1
18. Select RV 4 in the Site(s) Added list again
19. Check "Sub-member of" again
20. Change dates if necessary
21. Add Kayak 1
22. Done (after entering customer information of course)

Note that you can easily review any of the additions by selecting a particular site in the Site(s) Added list. The dates, etc. will be changed to match that site/reservation, and the grid will be moved if necessary to show the selected site (shown as <new> in the grid).

Automatic Multiple-Site Selection

If you're booking a large group and don't want to select specific sites manually, you can use the Qty entry field to let Campground Master automatically select and add as many sites as you need to the reservation. Note that this feature is disabled by default, but can be enabled through Maintenance / Program Options / Reservations.

To use automatic selection, first select the type of site and any preferences, and of course select the first and last night to be reserved. (If you don't care about the site type, or if all of your sites are the same, you don't need to select the type or preferences.) Enter a number in the Qty field, and click Add Selection(s). Campground Master will add as many sites as you request, starting from the top, including only sites which match the selected type and preferences and which are available for the dates selected.

Note that these selections will automatically be assumed to be synchronized with each other by default (they will be linked with the selected site in the Site(s) Added list using the linking option you choose, but they will be synchronized with each other). If you prefer that they be linked together as sub-members or non-synchronized instead, you can enter a qualifier in front of the quantity number (=, or # or > just like the link prefixes mentioned above) to specify how they should be linked together. The first site will be linked as selected in the checkboxes after Add Selection(s), but the rest will be linked to the first one depending on the prefix before the number. For instance, to add 5 sites all linked as non-synchronized, make sure that neither the Synchronized with nor the Sub-member of boxes are checked and enter "#5" in the Qty field, instead of just "5".

The Qty field can also be used to reserve multiple synchronized sites without assigning sites to them. (This will make them all unassigned and will require you to assign a site to each one individually before they check in, so use this with caution.) Simply enter a number in the Qty field, and enter all of the other information as usual. When you click Done or any of the other "completion" buttons at the bottom, it will create that number of unassigned reservations, all synchronized with each other.

Group Reservation Special Handling

Groups are generally just linked reservations with the Group reservation type. Working with them is the same as other linked reservations, with a few exceptions.

One difference you'll notice besides the color difference on the Rack is that group reservations will show "[Group]" in the pop-up tips for with the reservation customer, and will have a Group Leader. If this reservation's customer is not the same as the group leader, the group leader's name will appear in the pop-up tip as a group name, like "[Group : Good Sams]". Also note that the Master of a group (not the leader, but the Linked Master) will be shown in a darker color (according to the Color Key). This aids in separating groups visually if you have more than one group and they are next to each other, and also indicates which reservation should receive transactions as long as they are still synchronized.

When making group reservations, it works best if you make the initial reservation under a group name (add a customer whose Last Name is the group name you want to see, for instance). The first customer used for a group will automatically become the group leader for the group. You can change the customers for the individual reservations later (see below).

The group leader will also be shown in the [Reservation Details](#) dialog, along with a View button. You can use the View button to see the Customer Details for the group leader (and make changes if needed), but you cannot change which customer is the group leader.

The group leader information is really just a reference, and has no special function other than showing up in various places.

One advantage to a group reservation is that a "Change Customer" option will be available on the right-click menu if it hasn't been checked in yet. While Change Customer is always available on the Reservation Details dialog, it's handy to have on the right-click so you can change it just before checking them in (it appears right on top of the Check In option as a reminder) -- when an individual for a group arrives, first change the customer name (adding a new one if needed), and then check them in. Note that changing the customer will automatically un-synchronize the reservation, so that the check-in status (and dates if necessary) can be changed for just that reservation. Un-synchronizing also means that when the rates are selected, only the rates for that site will be shown.

Changing the Customer of a Reservation

If you need to change which customer is associated with a reservation, then you must use the "Change to a different customer" function in Reservation Details.

There is a very important difference between changing to a different customer using this function and just using Customer Details. If you just go into Customer Details, you're changing the global record for that customer, essentially wiping out the old customer information and replacing it with new information. This will affect **all** other reservations that customer might have, including previous reservations. In most cases this is not what you want to do -- for instance if you chose the wrong customer for the reservation originally, or if it's part of a group and now you need to make them separate customers, then **don't** use Customer Details.

Therefore you want to go into Reservation Details (e.g. from right-clicking on the Rack or through Find Reservation), and click the [Change to a Different Customer](#) button. This will open the Find Customer dialog where you can either select a previously entered customer or Add a New customer.

Important -- If the reservation is synchronized with others, you may get a prompt when you're finished for whether you want to keep it synchronized. If you only want to change this reservation, for instance if it's part of a group but will be paying separately, then you must answer "No" -- otherwise you're changing the customer for all of the linked reservations. If you don't get this prompt, then it either means that the reservation was already non-synchronized, or else it's making it non-synchronized automatically.

Hourly / Scheduled Reservations

A feature called "Schedules" allows any number of different intra-day schedules to be set up, and reservations made for sites in periods such as hours, 15-minutes, half-days or whatever. You specify what periods are included in each day, and they don't even have to be the same length. For instance, you might set up a "Tours" schedule that only has the periods "10AM", "2PM", and "4PM". Periods are just "time slots" that take the place of days, for instance on the Rack view.

To set up Campground Master to handle intra-day scheduled reservations, refer to Maintenance / Park Setup / Schedules.

Once schedules are set up, then you can set up "Sites" to correspond to events or items to be reserved for each schedule. For instance, Sites can be tours, boats, training classes, or anything needed. Reservations are made in much the same way as for daily-type sites, except that you also specify a first and last "Period" along with the dates. You can also set Blocked date/period, and of course the charged-through and paid-through dates also have periods.

There are two things that determine what schedule is to be used for a reservation:

1. The Reservation Type. Each schedule is restricted to one or more reservation types that you define in the Pick Lists.
2. The Site. Each site must be assigned to a particular schedule.

As a quick example, you might set up an "Hourly" reservation type, an hourly Schedule with periods from 8AM to 6PM that is only used for Hourly reservation types, and a number of Sites like canoes and kayaks that are assigned to the hourly Schedule. Whenever you select that reservation type, the New Reservation dialog will change to allow date and period entry for the reservation. When a site type is selected on the Rack View that only includes sites of a particular schedule, then the Rack will change to show a cell for each period instead of each day. (Likewise, the Rack can ONLY show sites assigned to a single period at a time -- so your canoes and kayaks would not be shown on the Rack at the same time as your daily sites.)

Making Reservations for Scheduled Periods

You can make reservations for schedules just like you would for daily sites -- using double-click from the Rack (if a scheduled site type is selected so the periods are shown), or from the New Reservation icon or menu function.

The key is to select the appropriate Reservation Type from the drop-down on the New Reservation dialog -- once a type is selected that's assigned to a schedule, the dialog will convert to a period-based dialog, adding "Period" fields next to the dates and changing the mini-rack to show periods (and only sites that are set up for that schedule).

It's likely that many of your scheduled-period reservations will be for the same customer that also has a daily site rented. In this case, you probably want to link them together and combine their billing. To do this, you want to locate their main reservation first, and go to Reservation Details. Then use the "Add Sub" button to add a Sub-member reservation. Now select the sites, periods, etc. as usual. (For a detailed example, see the previous sections "Linked and Group Reservations" and "Creating Linked Reservations".) When you're done making the reservation and go to Transactions, you can use Auto-Calculate or Select Rates to add the charges for the new reservations.

Monthly / Long-term Reservations

There is a variety of special functionality available to handle long-term reservations. This will help clarify some of the recommended procedures for handling long-term stays, particularly for those paying monthly.

The "Monthly" Reservation Type

First and foremost, any reservation that is charged on a monthly basis (as opposed to all at once) should have its Reservation Type set to "Monthly" (or any Reservation Type whose "Base Class" is Monthly in the Reservation Types Pick List. This tells the program to only charge one month at a time.

In addition, Monthly reservations are in a different color, and can have special rules apply for the initial dates and amount charged when it's first created (see Program Options / Monthlies). You can even specify a "month" to mean a specific number of days, instead of a calendar month, e.g. 30 days, for the purposes of "adding a month" to a reservation or auto-calculating a "month" at a time.

Finally, Monthly reservations are eligible for the Monthly Billing function to allow one-click billing of all due reservations at once.

Recommended Reservation Settings

For proper handling of long-term reservations, certain fields should be set initially and maintained properly, particularly if you're using Monthly Billing.

As mentioned above, the Reservation Type needs to be a Monthly-Base-Type (usually just "Monthly").

First-time Setup:

If you're just setting up Campground Master and entering reservations that have already been there, here are some rules to follow:

1. First Night: This shouldn't be in the future. Set it to an appropriate past date. It doesn't have to be exact, but it should generally be on their monthly anniversary since you're charging rent based on that. For instance if they started in 2016 but are next due on the 18th, you can set the First Night to the 18th of last month. However if they are past due on payments, it's best to set it as far back as needed so it starts before they were last paid in full. Of course they should also be set to Checked In. Make sure checking it in doesn't change the First Night from what was set above (answer "No" to the prompt that comes up about arriving today).
2. Auto-charged thru date: This should be set to the end of their last billing period. For instance if you've billed for the month of May already (prior to using Campground Master) and you're using calendar-month billing, set it to May 31st. If they start on dates other than the 1st, of course, it should be adjusted accordingly (e.g. if they Started on 4/11, the Auto-Charged-thru should be 5/10).
3. Paid-thru: This should reflect their actual payment status. If they are paid through 5/31, select that date. If they haven't paid for May, set it to 4/30 (again these assume calendar month billing).
4. Last Night: There are a couple ways to do this. Partly it's preference, and partly it's the way your park operates. But it can also affect how things like the Paid Thru tab shows them and also Monthly Billing. We suggest experimenting with each method to see what works best for you.
 - One month at a time -- If they arrived on 4/1, charged and paid thru 4/30, (and assume this is still April), then you can set the Last Night to 4/30. Then set the "Block To" date as far out as practical, e.g. to the end of the year, or net year, or when you really expect them to leave. Each month when it's time to bill, you can extend them another month.
 - All the way out -- The the Last Night as far out as desired, and rely on the Charged-thru and Paid-Thru to keep track of their status. This is really the recommended method, since the Monthly reservation type already keeps it from billing more than one month at a time. You won't have to keep extending them each month, and they will show up on the Payments Due tab as of when their next billing is due.
5. Security Deposits -- If they paid a security deposit in the past, you should enter this charge with some past date, along with a payment, so you have a record of it. That way it will balance out when they leave and you refund the deposit. See the Security Deposits section.

6. Electric Meters, etc -- If you're doing metered electric, be sure to set up for Electric Meters, and set the last reading accordingly so it's read for next month's new reading. Likewise for gas or water meters, if applicable.

New Monthly Reservations:

When creating new monthly reservations, it's mostly a matter of just using their arrival date as usual and then deciding how long they expect to be there. As mentioned in #4 above for Last Night, you can set the Last Night all the way out or just make it one month out and use Blocked To to hold the site for a longer time. For convenience, you can also set it to automatically extend the Last Night and Blocked To dates whenever you select the Monthly reservation type (see Program Options / Monthlies).

If you prefer to pro-rate the first month so that the next month's rent is due on the first of the month for everybody, you can also do that (see Program Options / Monthlies).

Of course if your renters pay a security deposit for damage or electricity, etc, then you should handle that as described in the Security Deposit section (under Working with Transactions).

Monthly Rates / Charges

As mentioned before, the Monthly Billing function can make it easy to handle the monthly billing chores. However this requires Auto-Rates setup. Even if you aren't ready for that yet and/or need to handle the monthly charges manually, here are some tips:

1. Make sure your Rates are set up appropriately for Monthly reservation types. See details in the Rates Setup Examples.
2. If you need to pro-rate partial months, either at the beginning of the stay or at the end (or both), you can set up appropriate rates to do that or you can let it use your normal Daily/Weekly rates. See details in the Rates Setup Examples.
3. If you're manually adding charges, even with Select Rates, it won't know what dates you're charging for -- so it may be useful to set the Auto-Charged-Thru date to the appropriate charged-thru date afterwards. This will help it set the Paid-Thru date accordingly. Of course if you're using Auto-Rates / Monthly Billing, this is automatic.
4. When a payment-in-full is made, it will set the Paid-Thru date to whatever the Auto-Charged-Thru date is set to (which is why setting it manually is handy). However if Auto-Charged-Thru is not set, then it will set the Paid-Thru to the Last Night. This is one case where extending the Last Night each month could be better than setting it far out initially.
5. If there are other standard monthly charges besides rent, such as for cable or trash service, those can be set as Add-On rates or they can be combined in the one Monthly Rate definition (assuming it applies to everyone). If special charges don't apply to everyone, then of course you would use an Add-On rate, using something like a Reservation Attribute field to indicate that the charge is required.

Electric Meters, etc.

If you also charge for metered electricity, then you can combine that on their monthly bill (e.g. using the printing option to Print "Unbalanced Transactions (since 0 balance)"). Usually it's recommended that you add the electric (and water and/or gas as needed) before doing the monthly billing -- especially if using the Monthly Billing function. That makes it easier to combine the charges onto one bill.

Of course you may want to use the Electric Meter Reading (Batch Entry) method of entering electric meter readings and charging those all at once as well. Since that also has functions to print all receipts, then you may prefer to add the monthly rent first, then do the electric readings and print from there.

Day Passes

If your park issues something like day passes, assumed to be a pass allowing them to come and go and be in the park any time of the day that it's issued, then the Day Pass function can be used for this.

Day passes are essentially a special kind of reservation without a site assigned, and are created the same way as reservations, using the New Reservation Dialog. Day passes do have a first and last night, a customer, transactions, etc., but do not need to be checked in or out. Once a day pass is created, its type cannot be changed.

To create a day pass, start with the New Reservation function, but not from a specific site -- use the Telephone icon, or start by adding a customer and then use the New Reservation function. Since the New Reservation dialog will default to "today", all you need to do once a customer info is entered is click the Day Pass button at the bottom. This is in the same place as the Check In button -- as long as no site has been selected yet it will be Day Pass, but if a site is selected it changes to Check In. Note that you can make day passes for multiple days, or you can start them at a later date if you like -- just change the dates as with other reservations.

At that point, you will be taken directly to Transactions / Select Rate(s), with the appropriate rates selected. (You should have one or more appropriate Rates defined as "rental" rates for the Day Pass reservation type.) Just add the appropriate rate from the list (double-clicking on it is quickest) and click Done. The Transaction dialog will then be shown so you can enter the payment and print a receipt.

There isn't a special receipt type for day passes, but any receipt printed will show "Day Pass" in place of the site number. The Window Tag is probably most appropriate for this, since "Day Pass" will be in a large font and could be used in a car window. (A separate receipt can be printed if needed, since the transactions don't show on the window tag.)

Day passes are handled in reports just like any other reservation that has no site assigned. The main difference is that normal reservations cannot be checked in without a site assigned, while day passes are assumed to be "checked in" as long as their date is current. Thus you will be able to see day passes on the On Site report, as well as the Arrivals, Departures, and Unassigned views. They will show "(Day Pass)" in place of the site name, to distinguish them from other unassigned reservations. They will typically be listed below any reservations with sites assigned to them, depending on the sorting used of course. A quick way to see the day passes is to select "Unassigned Sites" from the Site Type drop-down list on these reports (or go to the Unassigned report). Of course the day passes won't show up on the rack since they have no site assigned.

Making Changes to a Reservation from the Rack

Overview

Most changes to a reservation's dates or status can be done from the Rack view -- you can change the first and last nights, block dates, change sites, confirm, guarantee, and cancel a reservation all from the right-click menu on the Rack. An appropriate confirmation dialog will appear for any change, and in many cases you'll be automatically prompted for necessary details.

Of course you can also perform many of these through the Reservation Details dialog, but getting familiar with the right-click menu will help streamline the operations by minimizing the steps required.

Changing the Reservation Dates

You can change the first and last dates of a reservation at any time, as well as the Blocked date. (Exception -- the First Night cannot be changed if a reservation is checked in, and none of the dates can be changed if the reservation is already checked out).

The Blocked date allows you to block a site for extra days after a reservation's official Last Night, in case the customer wants to stay longer. This can be at your discretion to allow some slack for typical stay-overs, or by customer request. The dialogs Reservation Details and Change Site allow date changes directly, but most changes can also be made easily on the Rack view itself. See the *Rack* section for command details.

When changing the first night, last night, or blocked dates from the Rack view, you will get a simple confirmation so you can accept or abort the change. Not much can go wrong here, since only "valid" options will be available when right-clicking on the Rack.

If you do change the start date of a reservation that's not checked in yet, you will also be asked if they will be staying the same number of nights. If you answer No, the reservation's original Last Night will remain the same. If you answer Yes, then the Last Night will be adjusted automatically to make the number of days the same. The Blocked date, if present, will not be affected (unless the end date is now later than the original blocked date, in which case the blocked date will be cleared). If you find this prompt more of a burden than a help (i.e. if you nearly always answer No), then you can turn it off in Maintenance / Program Options / Prompts.

Changing Site Assignments

You can change the site assignment from the right-click menu in the tab view, or from the Assign or Change Site... button on the Reservation Details dialog.

When changing the site or assigning a site to an unassigned reservation, a dialog just like the New Reservation dialog will be used so you can do all of the same site preferences and vacancy checks to find a new site. Everything else will be filled in, so just click the Done button when finished selecting the new site.

Note that when changing a site, only one site can be selected for the reservation. To add additional sites you will need to use the Add Linked Reservations option, which is only available from the right-click menu on the tab views.

Moving Checked-In Reservations, or moving in the middle of their stay

If a customer has already checked in on a previous date and is changing sites later (e.g. they stayed at least one night on a different site and now want to move), then you should split the reservation before changing their site. Otherwise, it will move them for their entire stay including prior nights, which would be incorrect and could conflict with prior reservations on the new site.

Therefore, locate the reservation on the Rack and right-click on the reservation cell in the date they will actually be moving. Then select the Split Reservation option. This will create a secondary reservation starting that date, which you can then move to the new site. For more information, see the "Splitting Reservations" section. After the split, then right-click again and select Assign or Change Site to select the site for the new half.

Swapping Sites

If you have two existing reservations that you need to swap the sites for, there is an easy way to do this. First use the Assign or Change Site function as described above. Once that dialog opens up, locate the site/reservation you want to swap with. Since it's occupied, you can't just double-click on that site to assign it because that would create a conflict. However you can right-click on that reservation in that site and select Swap Sites with this reservation. If the swap would create a conflict with other reservations, or if the other reservation is flagged as "Don't Move", it won't be allowed. Otherwise it will ask for confirmation -- answer Yes and the swap will be done.

Changing the Customer

This function is only available on the Rack if the reservation is a Group reservation, and is not yet checked in. (It's also available on the Reservation Details dialog for any reservation, but requires Manager access if the reservation is already checked in.)

While not recommended in general, changing the customer with this function is much preferred to just editing the customer details to change the actual customer this reservation belongs to -- you should never just overwrite customer information with that of another customer, in case that customer record has been used for other reservations or transactions.

This will open a Find Customer dialog, where you can select an existing customer or click "Cancel / Add New" to enter a new customer for the reservation.

If the reservation already has transactions, all transactions will be transferred to the new customer, which could result in that customer's balance to be wrong -- make sure you know what the consequences will be (if the reservation has a balance due, it can result in the wrong customer getting a bill).

Also note that if this reservation is currently synchronized with others, it will no longer be synchronized after changing the customer. This is done without warning, since that's usually what you want to do (if it's a different customer, they're likely to check in or out at different times). However if the reservation has sub-members linked to it, then the customer will be automatically changed for its sub-member reservations as well.

Canceling a Reservation

A canceled reservation is not deleted from the system, it simply has a Canceled status set so that it will not show up on certain reports. You can cancel a reservation using the Cancel option on the right-click menus in the tab views, or you can click on the Canceled check box on a Reservation Details dialog.

Note: If a reservation is already checked in and now you need to cancel it (either due to a mistake or because the customer did not stay the night), you need to first change the status to Pending by checking the Pending box on Reservation Details.

When doing a cancellation, you will have a chance to select the Type of cancellation and (optionally) a Reason for the cancellation, and enter notes about the cancellation (it's always a good idea to note who requested the cancellation and why, so you have some proof in case they forget that they canceled it).

Cancel Type -- This is a fixed list of options which become the Status of the reservation. This is a broad explanation of the type of cancellation that was done -- e.g. if they called to cancel, or didn't call but didn't show up, or showed up but didn't stay, or if you canceled the reservation due to a mistake or for some other reason. This list cannot be changed. You can set a default Type selection in Maintenance / Program Options / Reservations.

Cancellation Reason (new as of version 11.0) -- These selections come from the **Cancel Reason** Pick List, which you can define. Select an appropriate reason that the cancellation was done. These will show along with the Type/Status in most cases. You can set a default Reason to be selected for each different Cancel Type, in Maintenance / Program Options / Reservations.

If you have the appropriate operator access, there will also be a button to the right to Edit pick list. You can click on that to directly jump to the Pick List editing function for the Cancel Reasons, without leaving the Cancel Reservation dialog.

Notes -- Any notes will be part of the reservation's Notes field, so if notes already exist you can add the cancellation notes to the end of the existing notes. Also remember that the date, time, and operator making the cancellation will be recorded, which you can see on the Reservation Details dialog.

After entering the details and clicking Save, the Transaction dialog will appear so that you can check the transactions for any refund needed or delete any charges for the reservation, or charge a cancellation fee. Don't leave unpaid charges on a canceled reservation or else your reports will be inaccurate, showing charges that were never paid. When canceling a reservation, the account should be "balanced out" so that the balance due is \$0.00.

You can **undo** a canceled reservation if a cancellation is done by mistake, or if the customer changes their mind. You can do this by clicking on the Pending check box in the Reservation Details dialog. A simple confirmation will be shown, at which point you simply click Yes to undo the cancellation. Manager access is required for this function.

You can also **change** the cancellation type or reason through Reservation Details, by clicking on the checkbox next to the current canceled status (which may also show "No-Show", "No-Stay", "Mistake" or "Other" depending on the current status).

Confirming a Reservation

To the Campground Master software, a *confirmed* reservation is simply a reservation with the Confirmed flag set. This flag is used to set the status color on the tab views, and optionally affect the showing of "available" reservations according to the Function options (see *Program Options and Settings*). For your campground, you may have no specific rules for requiring confirmations, so the use of this flag is at your discretion. (You could even use it for something totally different which you want to see coded as a different color on the tab views, although this could be confusing since the wording for the flag cannot be changed on the menus or dialogs.)

For now we'll assume that it means that a customer has confirmed their stay, so its confidence is greater than a mere "pending" reservation. This could be on a new reservation if it's close enough to the time of their stay, or done later on a reservation made months in advance. You can mark a reservation as "confirmed" from the right-click menu on the tab views, or from the Reservation Details dialog by clicking on the Confirmed check box. Note that the Confirm option will not be available on the right-click dialog if the reservation is already confirmed or if it has been Guaranteed (which is presumed to be a higher level of confidence than Confirmed). Of course it also won't be available if the reservation has already been checked in or checked out.

A simple prompt will ask you to confirm the change. If you are supporting the Estimated Arrival Time field, you may also want to set this when confirming the reservation. This field is available on the [Reservation Details](#) dialog.

If you want to undo a confirmation (to revert the reservation back to a *pending* state), open the Reservation Details dialog and check the Pending box (on uncheck the Confirmed box).

Confirmation Letters

After Confirming a Reservation, or possibly after adding a deposit and Guaranteeing a reservation, you may want to print or E-mail a "Confirmation" letter. This is done from the Reservation Transactions dialog -- accessed in various ways such as [New/Edit Transactions](#) from Reservation Details, [Quote/Confirmation](#) from Reservation Details, or right-clicking on the reservation in the Rack and selecting "Transactions".

If you want to include the charges for the reservation and expected balance on the confirmation letter but they are not yet added a transactions (remember that it is recommended that the charges NOT be added until they check in), then use the Quote/Confirmation function so that you can add the charges temporarily for the letter, but not save them as real transactions.

Printing a confirmation letter

Once in the Transactions dialog, select the desired Confirmation letter format from the receipt format drop-down list (above the "[Print Reservation Receipt \(All\)](#)" button), and then click the aforementioned Print button.

To change the details of the text or amounts shown on the confirmation letter, see Maintenance / Printed notices & text / Confirmation letter text & options. It's also possible to create special Confirmation text specific to certain sites -- see the Site Setup section for details.

E-mailing a confirmation letter

Once in the Transactions dialog, if you have enabled sending E-mail from the SMTP Setup (under Maintenance / E-mail Setup), then there will be an "[E-mail Confirmation](#)" button at the bottom of the Transaction dialog (if you don't see it, then you haven't done the SMTP Setup).

When you click the E-mail Confirmation button, if you only have one E-mail Form enabled then it will immediately open an E-mail window with the confirmation letter, where you can make any special changes to it and Send it. If you have more than one E-mail form enabled, then it will show a list of forms to select from first.

To change the details of the text or amounts shown on the confirmation letter, see Maintenance / E-mail Setup / Confirmation E-mail text & options. It's also possible to create special Confirmation text specific to certain sites -- see the Site Setup section for details.

Guaranteeing a Reservation

Like Confirmations, a guarantee is basically a flag in the reservation that affects the color coding in the tab views and may have an affect on showing "available" reservations (according to Rack options). In general it's assumed to mean that the customer has provided a deposit or credit card information to guarantee the reservation. You can mark a reservation as guaranteed by using the function on the right-click menu on the tab views, or from the Reservation Details dialog by clicking on the [Guaranteed](#) check box, or with the [Guarantee](#) button directly from the New Reservation dialog.

In addition to the "guaranteed" status indication, you can record the guarantee information with the reservation. When you guarantee a reservation, a dialog will appear for you to enter this information (unless it's disabled through Program Options / Reservations). You can enter any notes you like, and/or enter their credit card information.

Entering a Credit Card for Guarantee

Unless this has been disabled through Program Options / Reservations, you can enter credit card information to hold it as a guarantee for the reservation. Note that the security code cannot be entered since it's against PCI compliance to store that on a computer.

If the customer has previously guaranteed a reservation, or has credit card information from a previous payment, that information will be shown here automatically. (As per PCI compliance rules, the full card number will not be visible unless the logged-in operator has Administrator level access.) If this card is not correct anymore, you can re-enter it.

Note that the credit card number and expiration date will be verified when you click Save or one of the other options (below) to leave this dialog (it only checks the "checksum" of the card number, not whether it's an authorized card). If you have a credit card magnetic-stripe reader attached (and assuming you have the credit card in hand), you can simply put the cursor in the credit card number field and swipe the credit card, instead of typing it manually.

When the customer makes a payment later, the credit card information can automatically be retrieved from the guarantee information (depending on the credit card security settings).

X-Charge users: If you don't want Campground Master to store cards at all, then you can use X-Charge's secure "vault" for storing the card for guarantees. This is fully secure and does not store the card on your computer. You will still be able to see the last 4 digits of the card and expiration date, but will not be able to see the full card information. The card can then be used for a payment transactions if needed, depending on your Credit Card Security Settings. In order to use this function, you also must select the "Never save credit card numbers" option in Credit Card Security Setup, and be using the XpressLink interface for credit card processing. You will then have a button on the Guarantee dialog to Enter card information to secure vault. Click that button and X-Charge will prompt for the card information. You can also add or remove the secure vault information from the Edit Guarantee dialog (on Customer Details or Reservation Details, click the "..." button next to the Guarantee information).

Completing the Guarantee process

Once you have entered any guarantee information you need, you have several options:

Use the Enter a Deposit Transaction Now option to open the Transactions dialog so you can enter a deposit (which also goes to the "Deposit" function automatically)

Use Print a Quote/Confirmation Now to open the Quote/Confirmation (Transactions) dialog to show the expected charges and print a confirmation letter.

Use Continue to Reservation Details to get to Reservation Details for other functions (unless you're coming from the Reservation Details dialog already).

Or, you can simply Save the information and return to the previous screen.

Shortcut tip: If you are entering a deposit, you can skip the Guarantee step and go straight to Transactions (e.g. from the right-click menu). Assuming the automatically-guarantee option is enabled (see Maintenance / Program Options), the reservation will be set to guaranteed status when a Deposit transaction is added.

If you want to undo a guarantee (to revert the reservation back to just pending or confirmed), open the Reservation Details dialog and check the Pending box (or uncheck the Guaranteed box). Note that any guarantee information entered will not be deleted automatically (so it won't have to be re-entered) -- you will have to erase it manually from Reservation Details if you want it cleared.

Splitting Reservations

This function is only available from the right-click menu on the Rack view. The typical reasons to split a reservation include moving a customer to a different site in the middle of their stay, or adding a gap in the reservation when the customer leaves and will come back shortly.

Either way, you are actually creating an additional reservation. The Split function simplifies the process by copying all of the details to the new reservation automatically, and adjusting the dates so that the original reservation ends early (on the day before the split) and the new reservation starts the next day (the day of the split). Note that a split must be done in the normal range of the reservation, it can't be done in a Blocked date range. If you have other linked reservations synchronized with this one then they will also be split (assuming you confirm the prompt to keep them synchronized), resulting in two sets of synchronized reservations.

To execute the split, right-click on the reservation in the Rack on the day you want to start the split (the date that you want the 2nd half to start one). Select **Split Reservation at this date**. You will be prompted for how to link the resulting reservations -- you will almost always want to select the "RECOMMENDED" option, which is to make the 1st part a sub-member of the 2nd part. This will keep the later reservation as the "linked master", so it will have all of the transactions going forward.

If the split date is today or in the future, the second half will not be checked in yet (it will show a Pending status), even if the original reservation was checked in. If the split date is in the past, then both halves will keep the checked-in status (assuming it is checked in now). If both halves are the same status after the split, it may still appear like a continuous reservation on the Rack (if you don't have the start & end "bars" enabled), since it's still all one color and the same name. If you lose track of the split, you can double-click on the reservation to see the First and Last dates, so you can tell which of the two reservations you're clicking on.

After splitting the reservation, you can make the necessary changes to the new reservation just like any other reservation (change the start date, change the site, etc.).

Also note that transactions are not carried over in the split, since they can only be related to one reservation. If the original reservation had an outstanding balance, you may want to adjust its transactions to balance out to the day of the split and move the appropriate charges to the new reservation.

However, the Paid-Through date is automatically adjusted appropriately. If the original reservation was paid through the split date or later, that date will carry over to the new reservation and the old reservation will show that it's paid through its new last date. If the original reservation was not paid through the split date, then the new reservation will not have a paid-through date (none of it has been paid).

Linking options for split reservations

When you split a reservation, you will be given a choice of whether to keep the two parts separate from each other (not linked), or to link them as non-synchronized (for separate billing), or to link them as sub-members (for combined billing). If you're splitting the reservation for purposes of "starting over", for instance to start a new year for a long-term resident, then you probably want to leave them unlinked, or linked as non-synchronized so the billing is separated. If you're splitting them because you need to move the person to a different site but the stay is continuous, then they should be linked as sub-members so the billing is still combined. It's recommended to choose the sub-member option which makes the later half the new transactions master, so that this new portion carries all of the billing information.

What to do if there's no room to 'split'

Sometimes you want to make a new reservation linked to an existing one, but there's no room to use the Split function on the correct date. One option is to split it a day early, then move that extra day to the new site, then fix up the dates.

Another option, as of version 11.0, is to use the function [Add a New Linked Master reservation](#). This will make the new one a sub-member of the existing one, keeping the recommended organization where the later part shows as the main site on receipts and carries the transactions, since it will be checked out later than the old part.

1. Locate the existing reservation on the Rack (or On Site, etc).
2. Right-click on it, select [Linked Reservations](#), and then [Add a New Linked Master reservation \(making this its Sub-member\)](#).
3. The standard "New Reservation" dialog will open -- select the dates and then select the site for the new reservation as usual, and click Done.

'Undoing' a Split

If you split the reservations and then decided you didn't need it split, you can fix it but it may take a little effort. This assumes they are still on the same site, just appearing one after the other.

First figure out which of the two reservation halves has the transactions (assuming there are any transactions added yet). If the split was done with a sub-member option, it may actually look like transactions are on both reservations, but they will actually be linked to only the "Linked master" reservation. You can see which one is the Lined master by double-clicking on one of the reservations to get the quick-info window. At the bottom of this window it will show "This reservation is linked...", and one of them will have "[Linked master]" after it. Make a note of which dates are shown for that. Also be sure to make a note of the overall first and last night of the combined reservations, and also the Auto-charged-through and Paid-through dates, , since you'll need to know those to fix them later.

Now you need to go into Reservation Details for the reservation that is *not* the Linked master (the one without the transactions), and Delete it (click the Delete button at the top).

Next, go into Reservation Details for the remaining reservation and correct the dates and status. This may require undoing a check-out and/or check-in so the First and Last night can be changed, depending on the situation -- to undo Check-in or Check-out, click on the "Checked in" or "Checked out" box in the Status area of Reservation Details.

Now correct the First and Last Night to what they should be for the whole stay, and then if necessary do the Check-in again if they're a current reservation (be sure to answer "No" when it asks if you want to make it start today).

Finally, double-check the Auto-charged-thru date (if applicable) and the Paid-through date, which may have changed when the split was done, and update those to what they should be.

Fixing mistakes when splitting reservations

If you attempted to create a split reservation ended up with a mess, it can be challenging to correct the situation. Usually the best solution is to simply delete the "extra" reservations, put one back to the original site and dates, and start over. You'll need to locate the reservation that has any existing transactions and be sure to keep that one to start over from. There are some Newsletter articles that also offer tips (see our web site, or go to Newsletters under the [Help](#) menu).

There are also some functions for managing linked reservations that may help out (for linking and unlinking existing reservations), if you know more precisely what you need to fix.

Managing Linked Reservations

In Reservation Details, there is a list of linked reservations and a View function to open the selected reservation in a new Reservation Details dialog. There are also 3 separate "Add..." buttons to add more linked reservations. Each button will add reservations with linkages of the appropriate type. Note that it will be linking them to the reservation you're currently viewing in Reservation Details, **not** the one currently selected in the list! Also note that once you're in the Add function (which is the same as creating New Reservations), you can again add multiple levels of reservations.

Right-click functions

You can also perform link functions directly from the right-click menu on the Rack and other tab views. There is a Linked Reservations sub-menu, which allows adding the 3 different types of linked reservations mentioned above, change the way the selected reservation is linked to its owner, link existing reservations together, add a new linked master, and unlink reservations. (Some of these may be disabled depending on the current link status or type of reservation -- for instance, Synchronized reservations cannot be added to Guest reservations.) The options to change the linkage type can be used to combine or separate billing (change a sub-member to non-synchronized, or vice versa), or to change a synchronized reservation to a sub-member (combined billing) or non-synchronized (separate billing) so that the dates or status can be changed separately.

For more information, see the section "Linked and Group Reservations".

Synchronizing Linked Reservations

Any time changes are made to a reservation that is synchronized with other linked reservations, you will be prompted with an option to keep the reservations synchronized. This means that the same changes will be made to all of the linked/synchronized reservations, so they will all keep identical dates and status. It's very important to answer this correctly, since making the wrong choice can end up with a mess that's time-consuming to straighten out.

Answering No (to not keep them synchronized) will keep the changes from being made to the other reservations, but more importantly it will make this reservation a stand-alone reservation, no longer synchronized to the other(s). It will still be linked for reference and they will appear in each others' lists of linked reservations, but changes will not be synchronized (and the "synchronized" indication will be cleared). If this is done by mistake, the only recourse is to delete this reservation and add a new synchronized reservation to the rest of the group. If this was the Master for the synchronized reservations, the next one "in line" will become the new Master for any remaining synchronized reservations.

You will usually want to answer Yes to keep them synchronized, but there are some cases where you might want to un-synchronize them on purpose. For instance if one person in the party leaves early or stays later, you can separate him from the group. Another example is if you have two reservations linked for one person, such as a campsite and a trailer storage space, and you need to end one of them prematurely (e.g. he sells the trailer). The proper procedure in this case would be to Split the reservation on the date you want to cancel one of them, and tell it not to keep them synchronized. The first half of the split would remain synchronized, but the second half would be separated so you can cancel one of them.

The Reservation Details Dialog

This is the main dialog for editing everything about a reservation. While most common changes can be done outside this dialog (with right-click functions, for instance), some functions are only available here and nowhere else. This dialog also has a number of information fields that are not editable, such as the time, date, and operator who made the reservation, checked it in, checked it out, or canceled it.

Helpful Hint -- If you ever close the Reservation Details dialog by mistake (or the Transactions dialog for a reservation) and want to get back to the reservation you were just working on, use the shortcut **Ctrl-R** to recall the last reservation you were working on.

From this dialog you can open further dialogs to see [Customer Details](#) or [Transaction History](#), and to add [New Transactions](#), [Manage Guests](#), [Assign or Change the Site](#), or edit [Site Preferences](#). You can also [Print](#) a reservation record or [Delete](#) the reservation completely (if you're logged in as an Administrator), or [Find](#) a reservation if you're browsing from the main menu (see the Find Reservation Dialog below).

Note that the [Cancel](#) button on this dialog does not cancel the reservation! It only cancels any changes you have made to the fields, so you can avoid making changes by mistake. If you're just looking at the reservation and have not planned to make changes, you should use [Cancel](#) just to make sure you don't save changes made by errant keystrokes. If you make changes that you want to keep, use the [Save](#) button. (If you actually want to cancel the reservation, click the [Canceled](#) check box to start the cancellation process.)

Customer Details

This button will open the Customer Details dialog for the reservation's customer, so you can make additional changes or see more customer details. See *Working with Customers* for more information on this. If the customer has the "Warning Flag" set, you will see a red warning icon next to this button.

Note that there is no way to actually change which customer record is assigned to the reservation. You can change any of the customer details, but remember that those changes will be permanent in the customer database. If you selected the wrong customer for a reservation and want to change it once it's made, the only way is to delete the existing reservation and start over with a new reservation. (You could also cancel the reservation instead of deleting it, but that would result in a cancellation in your reports that wasn't really a customer cancellation.)

Cust. Bal. -- This amount is the customer's total balance due, which includes not only this reservation, but also any other reservations this customer has (past or future), as well as any transactions added to the customer directly, through Customer Details. Therefore it's normal to see this balance as a different number than the [Reserv. Bal.](#) in the below section.

Change to a Different Customer

This button allows you to change which customer this reservation is for. This should only be used if a mistake is made initially, or when checking in individuals from a group. If the reservation is already checked in, Manager access is required to change the customer record. To change the customer, click this button, which will open a Find Customer dialog. You can then select an existing customer, or click "Add New" to enter a new customer for the reservation.

While not recommended in general, changing the customer with this function is much preferred to just editing the customer details to change the actual customer this reservation belongs to -- you should never just overwrite customer information with that of another customer, in case that customer record has been used for other reservations or transactions.

If the reservation already has transactions, all transactions will be transferred to the new customer, which could result in that customer's balance to be wrong -- make sure you know what the consequences will be (if the reservation has a balance due, it can result in the wrong customer getting a bill).

Also note that if this reservation is currently synchronized with others, it will no longer be synchronized after changing the customer. This is done without warning, since that's usually what you want to do (if it's a different customer, they're likely to check in or out at different times). However if the reservation has sub-members linked to it, the customer for the sub-member reservations will automatically be changed to the new customer (because all sub-member reservations must have the same customer so their billing can be combined).

Manage Guests

This function opens a dialog for adding, viewing, and removing guests of this reservation. See the Managing Guests section for more details. The total number of guest reservations and any balance due for them is also shown for convenience. If you don't see "Manage Guests", then it's likely that there isn't a Reservation Type "Guest" (with the required "Guest" Base Type), or else it's been disabled. See Maintenance / Pick Lists / Reservation Types.

Reservation Status

The current status of the reservation will be indicated by a check-box. You can change the status by simply checking a different box (only those possible will be enabled), or by unchecking the box that's checked to undo a status like Checked In, Checked Out, etc. Any appropriate confirmation prompts or other messages will appear, the same as if the action is done from the right-click functions on the rack. The status of Day Pass and Owner reservations cannot be changed (they have no applicable status), so the status options will be disabled.

Activity History

This will show a summary of the date, time, and operator for when the reservation was made, checked in, checked out, and/or cancelled.

Don't Move

The Don't Move flag can be set if you want to avoid moving this reservation to another site. This will be flagged as such for color coding, plus the Assign Site functions will be disabled for this reservation.

Assign or Change Site

This will let you change the site assignment for the reservation -- see the section on Changing Site Assignments for more details.

Site Preferences

Although the reservation probably already has a site assigned, changing site preference settings can still be useful if the reservation rates are based on preferences (e.g. 50A, pull-thru, ocean view, etc.).

Reservation Type

Some reservation types can be changed and others can't. Guest and Day Pass reservation types cannot be changed, but you can change a reservation to and from Normal, Group, Monthly, Owner and Free Stay as needed. (Free Stay can only be selected if you have Manager access.) In addition, changes to the reservation type might be restricted based on your operator access level (configurable through Maintenance / Park Setup / Access Levels).

Guarantee Info

If the reservation has been guaranteed, this will have any notes or credit card information entered when it was guaranteed. While this field can be edited here if necessary (if logged in with a suitable access level so that the credit card isn't masked), this should be done with care. Putting information here won't automatically make the reservation guaranteed, nor will clearing the text undo the guaranteed status (use the status checkboxes for this). Also note that if credit card information was entered, this information is also in the guarantee info field in a special "encoded" format, so care must be taken to avoid corrupting that data. To edit the information without disrupting the credit card data, click the "..." button next to the text field. This will open a dialog with the credit card information and other notes separated and you can edit them as needed. Note that the credit card number may be masked, depending on your access level. If you need to change a number that is masked, you need to re-enter the entire card number.

Linked Reservations

If this reservation is linked with other reservations, they will be shown here in a drop-down list. (Although the list appears "enabled", you cannot change the contents of the list.) If this reservation is the Master of a synchronized list of reservations, it will show "Master of:" in front of the linked reservations. You can jump to the Reservation Details of the linked reservation shown by using the View... button next to it. Note that this will open a new Reservation Details dialog in the same position, and may happen so fast that you don't notice it. Be sure to check the Site field to see which reservation you're viewing.

You can also add additional linked reservations using one of the Add... buttons (see Groups and Linked Reservations for more details).

Group

If this is part of a group, the Group Leader (group name) will be shown, and there will also be a button to View the group leader's customer details. (Note that this views the Customer Details of the leader, not the Reservation Details -- use the View button next to the linked reservation list above to view the reservation details.)

The group leader cannot be changed for a reservation once it has been made (although its customer details can, but that would of course affect anything else that customer is used for.)

Label

If the Label Reservation field is enabled, it will be shown here. This is the only place you can change the Label, which is primarily used to override the text shown for the reservation on the Rack view (i.e. instead of the customer's last name). The label field is covered in detail in the Reservation Label Field section.

Disable automatic rate calculations

If auto-rates are enabled, there may be times when you want to disable the automatic re-calculations (for instance, if you are giving a special rate to a reservation). Check this box to prevent further automatic re-calculations.

New / Edit Transactions

This opens the Reservation Transactions dialog for the reservation, the same as using the Transactions function from the right-click menu on the Rack, etc.

Reserv. Bal. -- This is the total balance of transactions on this reservation. As mentioned above, it could be different than the total customer balance shown in the customer section. Note that if you are using post-dated Charge transactions (as enabled through Program Options / Transactions), then this balance **does** include any post-dated transactions. It's not simply the balance "as of today".

Transaction History

This will open a list of all transactions for this reservation, in the Transaction History dialog. This can be used for reference, or to print a complete transaction history. You can also use Transaction History to move transactions up or down in the list, to create a more logical ordering for prior transactions. (To edit the individual transactions or print a receipt, use the New /Edit Transactions option.)

Auto-Charged Thru

If auto-rates are enabled, this shows the last night that has been included in auto-rates calculations. This is primarily used for Monthly reservations, e.g. for the Monthly Billing function.

Quote / Confirmation

This is an extremely useful function, originally designed for generating a quote or checking rates and also for printing confirmation letters without actually adding charges to the reservation yet. It essentially opens the Reservation Transactions dialog, but with some important differences.

One difference from Reservation Transactions is that the default "receipt" type (and number of copies) can be set specifically for this function -- typically this is set to the Confirmation Letter. See File / Printing Options / Receipts to set the default. You can also send an E-mail confirmation to the customer instead of printing a confirmation letter. To enable this function, the SMTP Setup must be completed and the customer must have an E-mail address. A Send E-mail Forms button will be added to the Quote/Confirmation dialog if this is enabled.

In addition, it can be set to automatically add the appropriate charges as soon as Quote/Confirmation is opened (see the Auto-Rates Options in Program Options), so it can be used like the Check Rates function.

The main difference, though, is that transactions added here are not normally saved. Starting in version 10, however, it can either function the same way or it can save the transactions as post-dated. To see more about these options and proper usage, see the section Recommended Transaction and Reporting Methods.

Default/original Quote/Confirmation operation:

The default operation is that any transactions added during Quote/Confirmation will **not** be saved. Therefore you can auto-calculate charges (if enabled), select rates, or even add manual charges to the reservation for the purposes of printing a confirmation, without actually charging them yet. This can be important for accounting if you don't want to show charges until the reservation is checked in, or if you simply don't want to add transactions that might later have to be reversed.

All of the Payment/Deposit buttons are disabled -- this is to prevent these transactions from being entered here by mistake, since they won't be saved.

Optional Quote/Confirmation operation -- Saving Transactions:

If you have the system configured for post-dating charges to the reservation check-in date, you can also opt to have Quote/Confirmation save any transactions added. This includes the (post-dated) auto-rates charges, any manually added charges, and even Payments and Deposits. This means you don't have to switch to New/Edit Transactions just to enter the deposit. Since the charges (and any Deposit Applied) will be post-dated, they still won't appear on reports until the check-in date -- so it's "safe" to go ahead and save them immediately.

Online Req. text

This button will only appear if this reservation came from an online reservation request (processed by Campground Master), and if the Reservations data field "Online Raw" has been enabled so that the raw request text is saved. This allows you to view the original online request text in its raw form, just in case you need to review it.

Notes

Notes will be shown as a single line here, but you can enter multiple-line notes as long as you like by clicking the "..." button at the end of the notes entry field. This will open a separate Notes dialog for entering the notes. Any current notes will of course be shown, and the cursor placed at the end so you can begin entering notes immediately. When multi-line notes are displayed as a single line, for instance on the Detail dialogs or in lists, each line break will be shown as a double-backslash (" \\ ").

Journal...

In addition to the single-entry Notes field, you can add any number of Journal entries to a reservation, which are date/time/operator tagged. This can be used any way you like, for instance to track issues with the reservation, or make notes as to why certain changes were made to it. This button opens a list of existing entries and also the adding/editing functions. **Important:** The Journal entries for the Reservation record will not show up in the Journal for its Customer record, and vice versa. Likewise if a reservation is split or linked reservations added, the Journal entries will not show up on the other records. They are specific to that particular record.

Audit Trail...

This button opens the Audit Trail for this particular reservation, showing a list of all changes made to it (at least as far back as when version 6.0 was installed, since the Audit Trail function did not exist before then). Note that audit trail entries for any of the reservation's Transactions will also be shown, since they indirectly affect the reservation. There is also an option to also view entries for any Linked Reservations. However, Customer record changes will not be shown here -- to see those, go to Customer Details and then view the Audit Trail from there.

Printing a Reservation

You can print an entire reservation record or any reservation form with the Print button. This opens the Form Selection dialog, which gives you the option to print a grid or a form. The grid format prints a simple table with each field name and value, generally meant for reference purposes. You can also choose to print any Form defined for this type of record, which allows you to easily print a receipt, envelope, label, and any custom form you've created for reservations. (You can also print "Receipt" types of forms from the New/Edit Transactions dialog.)

E-mail Form

If you have SMTP set up, then you can send an E-mail directly from Reservation Details. This can be a free-form E-mail or a defined Form such as a confirmation letter or invoice. A Form Selection dialog will appear where you can choose what to send and whether to preview it first.

Deleting a Reservation

If you made a mistake in a reservation that can't be undone (such as selecting the wrong customer) or if you made a duplicate reservation by mistake, you may want to delete it entirely. Only an operator with Administrator access can delete a reservation, since it's a permanent deletion and can affect the integrity of the database if the wrong reservation is deleted. (This is another reason to avoid using an Administrator login unless you know that you need to make such changes.)

To delete a reservation, simply click the Delete button. You will be asked to confirm the permanent deletion. However, if the reservation has any transactions then it cannot be deleted. This is a safeguard to prevent deleting financial information by accident. Generally if a reservation has had transactions then it wasn't a mistake and should not be deleted, but perhaps just needs to be checked out or cancelled instead. If you absolutely want to delete the reservation and all of its transactions, you can go to the New Transactions dialog, delete all of the transactions, and then delete the reservation.

When a reservation is deleted, all references to it are cleaned up as well. This includes removing it from the reservation history of the customer and any guests, and removing it from any linked reservations. If this was the "Linked Master" for synchronized reservations, the next synchronized reservation in line will become the new master.

Temporary Operator Override

If you're entering a reservation but you're unable to complete a function due to your Operator Access Level, you don't necessarily have to go all the way out to have a manager log in. Just right-click in the caption bar, and select "Temporary Operator Override". That will allow someone to log in for this function only -- after leaving this dialog, it will revert to the previous operator automatically.

The Reservation Label Field

The Reservation field "Label" is disabled by default. Before enabling it (through Data Field Definitions), make sure you understand how it's used.

The Label field is designed for putting special notes or group names on the Rack like "Rally" or "Honeywagon". When this field is enabled, a Label entry field will be added to the Reservation Details dialog (it will appear toward the right center, below the Linking/group leader information).

Here are the key features of the Label field:

- The Label, if there is one, will show on the Rack instead of the Last Name.

- You can change the title of this field if desired (through Data Field Definitions), e.g. to "Company" or "Group", if you have a more specific use for it.
- The pop-up tip when hovering the mouse over the name on all Tab views (Rack, Map, On Site, etc) will show the full Label (in case it doesn't fit on the Rack) and also the customer name. The full label also shows up in the pop-up "Quick-info" window (e.g. when you double-click on it). So while the Rack only shows a short bit, a longer label can still be useful. In fact, you might want to start your labels with something that stands out like "!!!!!!", so that shows on the Rack to indicate a warning, and then put more the details after that so you can see them when you hover over it or double-click it.
- The Label field can be added as a separate column on most Tab Views (it won't replace the Last Name there, so it needs a separate column). See the Options for each tab view.
- The Find Reservation function can search by Label, and will show the Label column if applicable.
- If the reservation is linked with others, the Label is initially copied to each of the linked reservations by default. However if it's changed on a non-synchronized reservation, you will be asked if it should be changed for all linked reservations -- so different labels for each are possible.
- It's a Reservation field, not a Customer field, so for instance it won't "stick" to the customer for future reservations.
- It's not on the New Reservations dialog by default, because the only place it would fit is a common area for adding custom fields that each park might want different according to their importance. It can easily be added using a custom Dialog Definition. Otherwise, you can always set it through Reservation Details after making the reservation.
- When using the Search Grid function, the labels will also be included in the search (if the label field is being shown on the current tab view), with the same priority as the customer's last name.

Managing Guests

The Guest Management dialog is accessed from the [Manage Guests](#) button on the Reservation Details of the "host" reservation. If you don't see "Manage Guests", then it's likely that there isn't a Reservation Type "Guest" (with the required "Guest" Base Type), or else it's been disabled. See Maintenance / Pick Lists / Reservation Types.

A reservation's guest list is actually a list of additional "Guest" type reservations. There is no limit to the number of guests you can add to a reservation, and of course they are optional. The purpose of adding guests is simply to have information on everyone in your campground, particularly adults and additional vehicles. This can be for security purposes or simply to allow guests to be charged separately for the add-on charges for extra people and vehicles.

A Guest reservation occupies the same site as its host (thus many reservations can be made for the same site, presumably temporary guests of the primary ("Normal"), or "host" reservation. Since they are separate reservations, they can have their own charges just like other reservations, and will appear on reports like Arrivals, Departures, and On Site. On the Rack view, guests will be indicated on the pop-up tip when the mouse hovers over the cell, and will also be shown in the Quick-Info window (e.g. when the reservation is double-clicked).

To add a guest reservation, use the [Add a New Guest Reservation](#) button. (This function is also available from the right-click menu on the Rack.) This will open a New Reservation dialog, which operates just like any other new reservation except that the site is already selected and cannot be changed. Generally all you need to do is verify the dates (in case the guest is not staying as long), enter the customer information, and continue to charges/payment or check them in.

The First Night and Last Night for a guest must always be within the dates of the host reservation.

Since guests are separate reservations, they must also be checked in when they arrive and checked out when they leave. Guests will show on the Arrivals and Departures views so they can be checked in and out separately. Note that guests must normally all be checked out before the host reservation is checked out. Likewise, a guest reservation cannot check in before its host. If you want to allow guests and their host to arrive or depart in any order, you can allow this through a setting in Maintenance / Program Options / Reservations.

If a guest does not show up, or you need to cancel a guest reservation for any reason, you can use the Cancel Selected Guest Reservation function on the Manage Guests dialog, or you can cancel the guest from its own Reservation Details like any other reservation. It will be automatically removed from the host's guest list when canceled.

Note that the Reservation Type for guests cannot be changed. If a mistake is made and the reservation should not be a guest, the most likely recourse is to cancel the reservation and start a new one.

The Notes Dialog

The Notes dialog is used to enter multi-line notes, or just to get a better view of long notes. It is invoked from any dialog that has a "..." button at the end of a Notes entry field, such as the Site Details, Customer Details, Reservation Details, or New Reservation.

Any current notes will of course be shown here, and the cursor will be placed at the end so you can begin adding to the notes immediately.

Simply enter the notes as you want them to appear, using the Enter key to start new lines. Long lines will wrap around automatically in this dialog, but be aware that when showing the notes in the Quick-info pop-up windows, the lines won't wrap and may cause the window to be very wide.

When multi-line notes are displayed as a single line, for instance on the Detail dialogs or in lists, each line break will be shown as a double-backslash (" \\ "). Also note that extra "blank" lines at the beginning or end will be removed automatically.

Since both the Enter key and Ctrl-Enter are used to start new lines in the notes entry box, you must use **Alt-S** or click on the Save button to close this dialog.

The Find Reservation Dialog

This dialog can be opened directly from the main menu (Reservations / Find Reservation), or from the Reservation Details dialog if that was opened from the main menu. It's also used in various functions such as listing all reservations for a given site or conflicting reservations, so you can view or edit the details of each reservation. It can even be used to generate simple reservation listing reports with your own filtering criteria.

There is also a handy shortcut key that will open this dialog -- **Ctrl-F**.

The Find Reservation dialog allows you to search the reservation database in a variety of ways. By default, it will show all reservations that are on site during the next week (Filter by Date selected, starting today, ending 7 days later, and Resv period selected). In many cases, this may be sufficient to find what you're looking for (you can sort by any column shown to help you look), but several other options are available.

In addition to (or instead of) filtering by the reservation dates or the date the reservation was made, you can also filter by the Last Name, Confirmation Number, Site Name, Operator, or Notes, and also Label if that field is enabled. Any custom Reservation fields you've added will also be available to filter. To select one of these filters, first check the Filter by box. The default is Last Name, but you can change that in the drop-down box next to Filter by. Then enter the text in the next field, which will either be labeled "Starting With" or "Containing" depending on the search type selected.

When searching by Last Name or Operator, you don't have to enter the whole name, just the first part. Of course the more letters you enter, the more precise the search will be. After entering a few letters, press **Tab** or **Enter** (or click Search). A list of matches will show up, and you can scroll down the list to select another one using the arrow keys. When searching by Confirmation Number, Site Name, or Notes, any reservation containing the text entered will match (it doesn't have to start with the text entered).

If you prefer to see the entire list of reservations (not recommended for large lists of several thousand), you can uncheck both the Filter By option and the Filter by date option. All reservations will be shown, and you can sort by any column to help you find a customer.

For even greater control of what reservations to search or view, use the Reservation Filtering button.

Once a list is displayed, you can print the entire list, or print a Form for any reservations selected, by clicking the Print List / Forms button. Therefore this dialog can also be used to print out filtered reservation lists, or for batch-printing forms, envelopes or labels for selected reservations. Once this button is clicked, the Select Form dialog will allow you to choose what to print -- the list in grid format or a form for each selected reservation.

Once you find the desired reservation, select it by clicking the line with the mouse. The Search button will change to either View or Use, depending on what it will do (determined by how you came to the Find Reservation dialog). Click View or Use, or double-click on the reservation line, to complete the selection and perform the indicated function. (If only one reservation is displayed, you can simply press **Enter**).

Reservations by Date Made

This dialog can be opened directly from the main menu (Reservations / Reservations by Date Made).

You can enter any From & To date range to see the reservations created on those dates, and of course view the reservations as needed (click the View button or double-click on the reservation).

Unassigned Reservations

This dialog will show all "active" reservations in the system that don't have a site assigned. While the Unassigned tab view is similar, the tab view will only show reservations for a specified date range, whereas this report shows them for all reservation dates. You can also view the reservation details and make corrections directly from the list.

There is an option to include Waiting List reservations, which is similar to the Non-Reserved tab view except that it will show them for all dates (and only if they are not assigned to a specific site).

Reservations that are Canceled will not be shown, nor will Inquiry, Can't Book, or Day Pass reservations.

6 Working with Customers

Overview

Remember that "Reservations" are **not** the same as "Customers" in Campground Master. "Reservations" contain the information about a single stay for a particular customer, such as the dates, status, payments, site and so forth. If you want to work with the information pertaining to a particular stay, you should refer to Working with Reservations.

Adding Customers

During normal operations you should just enter new customer information on the New Reservation dialog as you make a reservation. To enter customer information without making a reservation, such as entering your old customer records, use the Customers / Add a New Customer from the main menu. You can also use the Add Customer button (faces icon) on the toolbar.

At this point you should see Record ID: <NEW RECORD> in the dialog, indicating that you are starting a new customer record. If you see any other record ID, then you are editing an existing customer record. The cursor should already be in the Last Name field, so you can just start entering the information, using the **Tab** key between each field. You can use **Shift-Tab** to back up a field, and of course you can use the mouse to jump to any field you like.

Note that most customer fields are free-form, so you can enter the text in any format you like and any length needed. For example, in the phone number fields you can put "Cell: 123-4567" or "555-1212 ext. 54". The only exceptions to this are the drop-down fields, which must be one of the selections in the list, and the numeric fields, including the Rig Size and the Adults, Children, etc. (Length fields can have a single-quote character, for "feet", but it is not necessary.) If any value is not valid, you will be warned before leaving the dialog and will get a chance to correct it. Any extra "spaces" typed at the beginning or end of entries are automatically removed, to avoid problems when sorting and searching for customers.

There are a couple fields that will do some auto-formatting for you. The State field will automatically be capitalized if only 2 letters are entered. Also, if a phone number is entered as simply 10 digits, or 11 digits with 1 as the first digit (no punctuation, spaces, or any other info), then it will automatically be formatted as (123) 456-7890.

When you're finished with a customer's information, you can click Save -- or you can immediately click Add New to add another record so customers can be entered one after another. Each time you click Add New, the current customer info will be saved and the cursor will immediately jump to the Last Name field to help speed entry. Another time-saver is to use **Alt-A** on the keyboard instead of using the mouse to click Add New.

If you decide not to enter a new customer, even after entering some information, click the Cancel button. You will be warned if any new information would be lost by canceling the changes to the record, so you can abort the Cancel and get back to the dialog to Save it instead.

The more information you can enter for a customer, the better. Besides the obvious reasons for having more information, some of the information will help save time later. For instance, some of the values are automatically transferred to reservations when making a new reservation, such as Adults, Children, Rig Type, and Notes.

There is no limit to the number of customers you can enter. You could enter every old customer you have information for, just in case they come back. But remember that the more customers you have in the database, the longer it will take to find a particular customer (for instance, locating a particular "Smith" when making a new reservation). It can also slow down operations, like loading up the Find Customer list. So a good medium would be to start by entering customers whom you know come back often. (Any currently booked customers and future reservations that are already booked should be entered through the New Reservations dialog so you can enter both customer and reservation information at once.)

Automatic Zip/Postal Code Lookup

For U.S. and Canadian addresses, you can speed data entry by simply entering the Zip or Postal code in the City field. When you press **Tab** or **Enter** after the code, it will automatically fill in the City, State, Country and format-corrected Zip/Postal code for you. Note that there is no need to enter the spaces or capitalize the letters in Canadian codes, it will do that automatically. You can also use the Zip+4 format for U.S. codes if you like.

Automatic Mixed-Case Formatting

If you prefer to have names and addresses capitalized but don't want to use the Shift key, you can turn auto-formatting on. See Maintenance / Program Options / Formats. Note that if this is enabled and it incorrectly changes something that should have stayed the way you typed it, then you can go back to the field and fix it. As long as the only change is upper or lower case, then it won't try to format it again.

Vehicles

In addition to the rig type, etc., up to 4 other vehicles can be entered for a customer. Use these any way you like -- for cars, trailers, boats, bicycles, off-road vehicles or anything else you need to keep track of. The first vehicle ("car") is shown here, but you can enter more by clicking the More Vehicles button. While the fields are free-form, we suggest the license plates be entered as state/license (using 2-letter state codes) just for uniformity and ease of sorting if necessary.

Discounts

The discount options can be used to help select appropriate rental rates. You can enter up to 3 discounts that a customer qualifies for, and optionally enter their membership numbers. The first discount shown will automatically be used when they make a reservation (but can be changed manually if needed), and the appropriate rates for that discount (if defined) will appear in the rates selection list on the Transactions dialog. Also note that if transactions are entered later using a discount that's not one of the 3 the customer has, it will be added to the customer record automatically if there's an empty space for it.

Exclusions

The option for excluding the customer from the mailing list can be used if the customer requests to be removed from your mailing list. While it won't affect printing receipts, you can filter them out when printing mailing labels and envelopes. The E-mail list exclusion will work similarly, although support for E-mailing customers is not present in the current software version.

Warning Flag

The warning flag can be used to black-list customers or for any other purpose where you need to check the customer's information before making a reservation for them (you should indicate the reason for the warning in the Notes field). If this flag is checked, then a bright red warning icon (an exclamation point in a triangle) will appear on this dialog, plus the Reservation Details and the New Reservation dialog when that customer is selected. Customers with warning flags also appear in red on the Find Customer list. It doesn't prevent any action, it just warns you that you need to check the notes. You can get a list of all customers with warning flags with the menu function Customers / Customers with warning flags.

Viewing and Editing Customer Information

To edit any customer, you can use the [Add Customers](#) button (faces icon) on the toolbar or the [Customers / Customer Details](#) selection on the main menu. If a customer was not already selected on the current tab view, you will then need to use the [Find](#) button to get to the one you want to view or edit (see below). If you enter part of the customer's Last Name before clicking [Find](#), then that will automatically be used to do an initial search. (This must be done on a "New Record" -- don't try to do it on top of an existing customer record!)

The quicker way to get to a customer, if you have a current reservation for the customer, may be to find them on the On Site tab or other tab view and use the right-click function [Customer Details](#) (right-click directly on the customer's name to edit that customer). Or if you already have a [Reservation Details](#) dialog open, just click the [Customer Details](#) button.

In any of these cases, the Customer Details dialog will open. (This is exactly the same dialog that's used to add customers in the previous section.) However, if you open it for a particular customer (from right-click or from a [Customer Details](#) button), there won't be any navigation buttons. Therefore you can only see that one customer. If you used the main menu or the toolbar to view customers, you will see buttons to navigate between customer records. You can use the navigation buttons to step through customer records. The [Previous](#) and [Next](#) buttons step forward or backward, as expected. The button to the left of [Previous](#), which looks like |<<, will jump to the very first record (it's meant to look like the "back-to-beginning" button on audio tape and CD players). Likewise, the >>| button to the right of [Next](#) will jump to the very end of the database.

At the top you will see something like "Record 5 of 53", and a [Record ID](#). Don't be alarmed if the Record ID doesn't match the record number -- there can be gaps due to deleted customers. The Record ID is a fixed stamp on the record that's used by reservations and transactions to refer to the customer. The other record number is simply a sequential number that is just used to indicate where you are in the database, and is not part of the actual customer record.

See the [Adding Customers](#) section for more details on entering the customer information.

[New Reservation](#) can be used to immediately make a new reservation. It is unique in that it will save the customer information and close the Customer Details dialog first, and then open the New Reservation dialog with the customer information filled in. (It closes the Customer Details dialog first to avoid circular dialog problems.)

[Reservation History](#) will open a list of reservations that this customer has made or has been a guest of. It contains a summary of the reservations, with their current status flags (checked in, canceled, etc.). To see more information, you can double-click on it or click once and then click the [View the Selected Reservation Details](#) button, which will open the standard Reservation Details dialog, where you can make changes if you wish. If any old reservations have been purged for this customer, you will see "Reservations" and "Nights" totals for the reservations previously purged. This will tell you how much the customer has stayed in the past that's not in the current "live" reservations list.

Warning -- Be careful when going this far to edit reservations, since it's possible to start from the reservation dialog, click to customer details, click to reservation history, and click to edit the same reservation but in a different dialog (you're several layers deep at this point). The results are unpredictable for this circular situation, and depend on whether you click [Save](#) or [Cancel](#) at each step of closing the dialogs.

[New/Edit Transactions](#) can be used to directly enter or edit transactions for this customer. Keep in mind that these transactions will not be associated with a reservation! Only use this if entering non-reservation transactions, such as gift shop purchases.

[Transaction History](#) will open a list of all transactions for this customer (including all transactions made for every reservation by this customer), in a raw table format. This can be used for reference, or to print a complete transaction history. If any old transactions have been purged, a "Total Payments" amount will be shown for transactions previously purged. This will tell you how much the customer has paid in the past that's not in the current "live" transaction list.

When you're finished editing a customer's information you can click Save, or you can click Cancel (or the **Esc** key) if you were just looking and don't plan to make any changes. If you were editing and decide not to keep changes you've made, click the Cancel button. You will be warned if any new information would be lost by canceling the changes to the record, so you can abort the Cancel and get back to the dialog to Save it instead.

Guarantee Info

This shows the last information used to guarantee a reservation. Changing it here won't affect any current reservations, but would be used as the default information used for the next reservation guaranteed. Note that any credit card information may be masked for security (depending on the Access levels settings). If the credit card is masked, then you need to use the "..." button to make any changes. If it's not masked, then you could edit the field directly (e.g. add a note to the beginning), but we don't recommend changing the existing information.

Printing Customers

You can print an entire customer record or a customer form with the Print button. This opens the Form Selection dialog, which gives you the option to print a grid or a form. The grid format prints a simple table with each field name and value, generally meant for reference purposes. You can also choose to print any Form defined for this type of record, which allows you to easily print a receipt, label, invoice, or any custom form you've created for customers. (You can also print "Receipt" types of forms from the New/Edit Transactions dialog.)

E-mailing a Customer

If the customer has an E-mail address entered, you can click on the blue "E-mail" tag next to it to send them an E-mail. This normally opens your E-mail application, e.g. Outlook (assuming Windows knows your default E-mail application), with the customer's E-mail address already filled in. However if the SMTP Setup has been done in Campground Master, then the internal E-mail function will be used instead of your default Windows E-mail application, and you can also E-mail a form (see below).

If you want to include more than one E-mail address for a customer, you can put multiple addresses in the same field, separated by a semicolon (;). When sending mail through Campground Master, it will be copied to each address. Example: joe@aol.com;sam@gmail.com

E-mail Form

If you have SMTP set up, then you can send an E-mail directly from Customer Details. This can be a free-form E-mail or a custom Form. A Form Selection dialog will appear where you can choose what to send and whether to preview it first.

Notes

Notes will be shown as a single line here, but you can enter multiple-line notes as long as you like by clicking the "..." button at the end of the notes entry field. This will open a separate Notes dialog for entering the notes (discussed in the *Working with Reservations* section) . Any current notes will of course be shown, and the cursor placed at the end so you can begin entering notes immediately. When multi-line notes are displayed as a single line, for instance on the Detail dialogs or in lists, each line break will be shown as a double-backslash (" \ ").

Journal...

In addition to the single-entry Notes field, you can add any number of Journal entries to a customer, which are date/time/operator tagged. This can be used any way you like, for instance to track customer comments, or make notes as to why certain changes were made to it. This button opens a list of existing entries and also the adding/editing functions. **Important:** The Journal entries for the Customer record will not show up in the Journal for any of its Reservation records, and vice versa. They are specific to that particular record.

Audit Trail...

This button opens the Audit Trail for this particular customer, showing a list of all changes made to it (at least as far back as when version 6.0 was installed, since the Audit Trail function did not exist before then). Note that audit trail entries for any of the customer's Reservations and Transactions will also be shown, since they indirectly affect the customer.

Temporary Operator Override

If you're entering a customer but you're unable to complete a function due to your Operator Access Level, you don't necessarily have to go all the way out to have a manager log in. Just right-click in the caption bar, and select "Temporary Operator Override". That will allow someone to log in for this function only -- after leaving this dialog, it will revert to the previous operator automatically.

The Find Customer Dialog

If you want to find a particular customer (or print a customer report), you can use the Find button on the Customer Details dialog. If you enter part of the customer's Last Name on the Customer Details dialog before clicking Find, then that will automatically be used to do an initial search. (This must be done on a "New Record" -- don't try to do it on top of an existing customer record!)

You can also get to this by using the Find Customer button from the New Reservation dialog, or by using the main menu selection Customers / Find Customer. If you tend to use Find Customer most of the time before adding a new customer, there is an option to make the customer toolbar icon go directly to Find Customer instead of Add New Customer (see Maintenance / Program Options / Functions).

There is also a handy shortcut key that will open this dialog -- **Ctrl-U**. (Ctrl-C would have made more sense, but that's a standard command reserved for the "Copy" function by most Windows programs, including Campground Master.)

The Find Customer dialog allows you to search the customer database in a variety of ways. If you don't enter part of a customer's name before clicking Find Customer, then the initial list will either be blank or it will have the entire customer list, depending on the option selected in Maintenance / Program Options / Functions.

Note: If all customers are shown initially, only the most important fields are shown to make it faster (name, city, state, and notes), but after making any filter changes the fields shown will change according to the filter type. For instance if you do want to see all of the fields for all customers then you can check and then uncheck the Filter By box to refresh the list.

If you did enter part of the last name first, then of course the list will already show matching customers.

Regardless of what's shown initially, the default search method ("Filter by") is Last Name, and the cursor will already be in the "Starts With" field ready for you to type a name. You don't have to enter the whole name, just the first part. Of course the more letters you enter, the more precise the search will be. After entering a few letters, press **Tab** or **Enter** (or click "Search"). A list of matches will show up, and the first entry will be selected by default, and you can scroll down the list to select another one using the arrow keys.

Note that Last Name searches have a special feature -- while it indicates "Starts With" as the search type, it will actually look for any *word* in the field starting with the text. So for instance a search for "Horn" will also match last names "van Horn", "Smith & Horn" or "Smith/Horn", so you can enter multiple last names in the Last name field and still locate them.

If you prefer to see the entire list of customers (not recommended for large lists of several thousand), you can uncheck the "Filter By" option. All customers will be shown with nearly all of their information, and you can sort by any column to help you find a customer.

Other filtering options include address, city, state, zip, country, phone number, E-mail, driver's license, vehicle license, discount type, discount ID, and notes. Any custom fields you've added will also be available to filter. The searches are somewhat intelligent -- for instance, a phone number search allows you to enter any portion of a phone number, and any punctuation is ignored. For instance, entering "555" will match any phone number (in any of the 3 phone number fields) containing three 5's in a row, even if they are separated like in the number (915) 552-0406. In addition, the list will always show the appropriate fields -- for instance, if you search by zip code, the address fields are displayed but not the phone numbers or licenses.

Once a list is displayed, you can print the entire list, or print a Form for any customers selected, by clicking the [Print List / Forms](#) button. Therefore this dialog can also be used to print out filtered customer lists, or for batch-printing forms, envelopes or labels for selected customers. Once this button is clicked, the Select Form dialog will allow you to choose what to print -- the list in grid format or a form for each selected customer.

You can also use [Export List](#) to export the data to a CSV file.

Note: Customers with warning flags will be shown with a red background -- but if it's the currently selected customer, it will be in blue due to the selection highlight.

Once you find the desired customer, select it by clicking the line with the mouse and clicking [Use](#) (the Search button automatically changes to Use once a customer is selected), or double-click on the customer line. (If only one customer is displayed, you can simply press **Enter**). This will open the Customer Details dialog for that customer, or if you're making a new reservation it will put that customer information in the reservation. A shortcut to using the mouse to click on a customer is to press **Alt-G**, which will jump "into" the grid, then use the up/down arrow keys to select a customer.

If you don't find a customer or you're finished with finding customers, typically you would click Cancel. In some cases, the Cancel button may show "Cancel / Add New", in which case that will take you right to the Add New Customer dialog ready to enter a new one (this depends on how you got to Find Customer in the first place). This is probably what you want to do in most cases, but if it's not then just Cancel out of that dialog also.

Add New Customer

In some cases, an [Add New Customer](#) button will be available so you can add a new customer instead of selecting a different one, for instance if the customer you're looking for isn't in the database. Just use this function to enter the customer information, and that new customer will be used for whatever function you're working on.

Merge Customers...

You will also see a "Merge Customers.." button in the dialog. This is useful if you see multiple customer entries for a customer that you know are really the same person. This button will be enabled if you select 2 or more customers at once, and will allow you to merge them safely.

Merging Customers

Duplicate customers may be added by accident if the operator doesn't use the Find function often enough when making reservations, or if the customer isn't noticed in the list. Under normal circumstances you would not want to delete one of them, since that would lose any reservations or transactions made with that customer. However, the Merge Customers is a safe way to combine them -- all of their reservations and transactions will also be combined into a single customer.

Merging Customers is done by first using the Find Customers function to find likely candidates for merging. Duplicates will likely be spotted accidentally on occasion when doing a Find for other reasons, but you can manually search for duplicates to merge any time. Just open the Find Customer dialog and search for all customers with last names starting with "A", for instance, and then go through the list.

If you find multiple entries in the customer list for the same person, select all of the ones to merge (using **Ctrl**-click on each one), and press the Merge Customers button. The Merge dialog will open, listing each of the ones you selected.

Note: Merging can only be done by operators with Manager access level or higher. The Merge Customers button will not be enabled for lower access levels.

The Merge Customers Dialog

The customers selected to be merged are listed in the Merge Customers dialog. Now you will need to select the customer record to "Remain" after the merge.

Note: The merge function only moves reservations and transactions from the duplicate customers to the customer to be kept, and deletes the duplicate customer record(s). If some information is missing from the "keep" customer then you need to copy it over before completing the merge function.

Some of the most critical information about each customer is shown in the list to help you make the decision. Typically you would choose the record with the most up-to-date or most complete information. If you need to see more details, or if you see some information in one that you want to transfer to the one to be kept, you can use the View Customer Details button at the bottom (or double-click on the customer).

Once you're sure that all of the information you need is in a single customer record, make sure that customer is selected (highlighted in dark blue), and click the "OK, Merge!" button. The reservations and transactions from all of the customers will be moved to the selected customer, and rest will be deleted.

Important! The Merge function cannot be reversed! Make sure you have recent backups, especially if you're using the auto-save option.

Customers with Warning Flags

A customer's warning flag can be set on the Customer Details dialog. This report will list all customers in the database with warning flags for a quick reference or to allow printing them out. Since the warning will show up as a bright icon whenever you start a new reservation or view the details for a customer, it's not necessary to use this separate reference most of the time. It's mainly here for convenience in printing the list, but may also be useful for printing a report showing all of the reasons customers get put on warning (the Notes field is shown, which should be used to indicate the reason).

Once the list is shown, you can double-click on any entry to open the Customer Details for that customer, and make any changes if needed, including taking them off the warning list. If you do remove their warning flag, the list will be updated immediately.

Deleting a Customer

If you created a customer by mistake, you may want to delete it entirely. Only an operator with Administrator access can delete a customer, since it is a permanent deletion and can affect the integrity of the database. If you just want to get rid of a duplicate entry, you should use the Merge Customers function instead of just deleting it.

To delete a customer, simply click the Delete button in the Customer Details dialog (available from the Customers main menu or by clicking the Customers toolbar button. You will be asked to confirm the permanent deletion. However if the customer has any transactions or reservations then it cannot be deleted, and you will be notified of the reason. This is a safeguard to prevent deleting financial information or reservation history by accident.

If you absolutely want to delete the customer and all of its transactions and/or reservations, then you can do so by following this procedure (starting at the Customer Details dialog showing the customer to be deleted):

1. Click the Reservation History button.
2. Click on a reservation in the list and click View the Selected Reservation Details.
3. Click on the New Transactions button.
4. If there are any transactions in the list, delete them:
 - a. Click on transaction in the list
 - b. Click on Delete Selected Item(s).
 - c. Repeat steps a and b for each transaction.
5. Click Done on the Transactions dialog.
6. Click Delete on the Reservation Details dialog.
7. Repeat steps 2 through 6 until all reservations are deleted.
8. Click Close on the Reservation History dialog.
9. Click Transaction History to see if there are any more transactions for this customer.
10. If there are no transactions, then Close the history and click Delete to delete the customer.
11. If there are transactions, then you will need to do the following to delete the transactions:
 - a. Close the customer dialog with Save or Cancel.
 - b. Open the New Transaction dialog with Transactions / Add a New Transaction.
 - c. Click Find Customer, locate the customer in the list, click on it, then click Use.
 - d. Click Enter New Transactions for the above Customer.
 - e. Delete transactions as in steps 4 and 5 above.
 - f. Return to the Customer Details dialog, find this customer and click Delete.

Administration note: It is possible to change the customer link for a reservation using the Maintenance / Raw Data Tables / Reservation function, and manipulating the numerical index values. This will not be discussed here since it is very intricate and dangerous. If you feel this is necessary, contact technical support.

7 Working with Transactions

Adding Transactions

There are basically two ways to enter transactions -- either through the Transactions Dialog used for normal charge/payment transactions (for reservations, customers, and unbound transactions), or through separate transaction entry dialogs for Expense and Misc. Income transactions. Note that only operators with Manager access or above can enter Expense or Misc. Income transactions. Any operator with Clerk access or higher may enter other transactions.

This chapter goes into detail for all of the Transaction-related functions. For the basics of how to get started entering transactions for your customer's reservations, refer to the Transactions topic in the *Working with Reservations* chapter.

How Transactions Work

You may be used to thinking of a "transaction" as being a complete financial deal -- for instance, the rent charges, the taxes, and the payment. In Campground Master, this would be recorded as 3 separate "Transaction" records, essentially one for each line on a receipt. This level of detail allows Campground Master to generate a number of very useful and flexible financial reports.

The Campground Master transactions data is a very simple collection of individual transaction "line items". Each record is essentially an individual line item -- a single charge for a number of nights, a sales tax charge, a payment, a refund, and expense entry and so forth. These are tied together into something useful by the way they are linked to reservations and/or customers.

You can also use Campground Master to enter all of your campground expenses and miscellaneous income if you like, replacing the functions of a general ledger. You can generate a variety of reports for accounting purposes, such as a detailed expense report for the year or a categorized monthly income and expense report.

Each transaction has a number of fields for classifying, categorizing, calculating, and reporting purposes. The primary field is the **Type**, and then there is a **Category**, a **Description** (you can enter what you like), a **Payment Type**, the **Discount Used** if applicable, a **Quantity**, the **Each**, and **Total** (automatically calculated).

In addition, every transaction is stamped with the date-made, time-made and the operator who entered it, plus a separate Date and Time which is assumed to be the "Posting" date. Normally these are the same, but it's possible to alter the Date and Time fields to reflect the actual date/time of the transaction for reporting purposes.

For reservations, all transactions for the reservation are linked together so that you have a record of all charges and payments for that reservation. If it's a monthly reservation, you can add charges and payments as needed for each payment period, and print out a receipt with either a complete history or just the new transactions each time.

Transactions for reservations (and customers) are typically entered in charge/payment pairs. That is, you add "charge" transactions such as daily rate charges, discounts and taxes, then you add "payment" transactions such as deposits, payments, credits and refunds. In the end, these should all balance out to a zero balance if the account is paid in full. The order of the transactions makes no difference (for instance a deposit is usually entered long before any charges are applied). They will still show up appropriately grouped on the receipt.

For customers, all transactions are linked together for every reservation the customer has made, plus any reservations that have been entered for the customer outside a reservation. For example you can enter gift shop purchases for a customer and print a separate receipt for that purchase, and it won't show up as part of the reservation transactions. You can also get a list (and print a statement) for all of the customer's past transactions at once, for instance a summary for when they leave.

In addition, you can enter "unbound" transactions. These would include your expenses and miscellaneous income, but also any transactions that don't have customer information, such as a walk-in to buy RV supplies that you don't want to add to your customer database. If you have the P.O.S. option, then the Point of Sale function is normally used for merchandise instead of Unbound transactions, but the concept is the same.

Deposit Balance

Advance Deposits (not to be confused with Security Deposits) are tracked so that the program knows which deposits have actually been applied, rather than just deposits paid. This will primarily be noticed in that whenever a non-deposit transaction is added to a reservation after a deposit, a "Deposit Applied" transaction is automatically inserted. This won't show on receipts and doesn't affect the customer's actual balance, and is only used for reporting and balance-tracking.

There is a "Deposit Account" Quick-Report under Transaction Summary Reports for showing the current deposits account balance (and the running total at any time in the past), and also a Deposit Balance Adjustment function under Maintenance for entering manual adjustments if needed to keep it synchronized with external accounting.

Note that the balance is actually calculated on-the-fly from all transactions in the database. Thus the balance can be shown for any previous day in the database's history.

A/R Balance

As with Deposits, the program can calculate the Accounts Receivable balance at any time. This is essentially based on the total outstanding balances (charges less payments) for all transactions. Deposits are not included until they are Applied, so unapplied advance deposits don't affect the A/R balance.

There is an "Accounts Receivable" Quick-Report under Transaction Summary Reports for showing the current balance (and the running balance at any time in the past), and also an A/R Balance Adjustment function under Maintenance for entering manual adjustments if needed to keep it synchronized with external accounting.

Note that the balance is actually calculated on-the-fly from all transactions in the database. Thus the balance can be shown for any previous day in the database's history. However this also means that any "future" charges (charges added for future reservations) will also be included in the calculation, so if you add charges (or payments) ahead of time for customers not yet arrived, be aware that this will affect your A/R balance.

Transaction Types

Every transaction must be one of the predefined Types. The type of the transaction determines where it appears on receipts, how it is handled for reports, and whether it's a debit or credit to the customer (for receipts and the customer's balance) and to the campground (for reports).

Charge

This is the standard transaction type for any purchase or other charge to the customer. A Charge transaction can have a category (selected from the Transaction Category list you define), a quantity, a price for each, and the total amount (calculated by the software). The description defaults to the category selected for convenience, but can be changed to be more specific.

Charges can also have a Discount Used, which is a selection from the discount types. This is used for generating reports to show how much of the charges were based on each discount type.

Tax

This is similar to a Charge, but is only used for adding taxes to the statement. Besides reporting purposes, it's separate from the Charge type so that taxes can be shown separately on receipts. A Tax transaction will have a category (typically a special selection such as "sales tax" or "hotel tax"), and has quantity/each/total values (see below for a suggestion on these). The description defaults to the same text as the category.

Discount

This is essentially a negative Charge, used for indicating the amount of discount separately from the charge, both for reporting purposes and for the customer's convenience on the receipt. For instance, if the normal rate is \$20.00 and the Good Sam rate is \$19.00, you should enter a Charge of \$20 and a Discount of \$1.00 to get the same result. That way there's no confusion of whether they received the discount rate, they can see exactly how much they saved, and you can generate reports showing how much each discount program is "costing" you.

Discount transactions can have their own category, or you can use the generic "Discount" category. You can set the quantity and each price just like Charges – for instance, enter the number of days for Qty and the discount per day in Each. The Discount Used field will be set appropriately (from the Pick List), and the description defaults to the Discount Used also. Note that Discount transactions will be shown on receipts with a "Discount : " prefix in the description, unless the description already contains the word "Discount".

Payment

This is the general payment type, for a customer paying his bill. It will have a Payment Method (cash, check, Visa, etc.). The Qty is typically left blank, so it just has an each/total value, but a Qty can be entered for special payment types like Traveler's Checks if you prefer. The category is predefined as "Payment" and cannot be changed, and the description defaults to the same as the Payment Method selected in the dialog, but can be changed to something more specific if desired.

Deposit

Note that this refers to "advance" deposits, i.e. payment before a stay, not to be confused with "security" deposits, e.g. payment kept for possible loss or damage. Deposits are basically the same as payments, just separated for clarity on the receipts and for reporting purposes. In addition, the program keeps track of a "unapplied" deposits as a deposit account balance. Whenever a charge transaction is entered *after* a deposit, a separate Deposit Applied transaction will be inserted to show that this deposit has been applied and is now earned income.

Deposit Applied

This is an automatic transaction -- there is no way to add it manually. It's added whenever a Deposit is "used", i.e. a charge has been added to a reservation that had a deposit. These transactions show an "Each" amount, but they don't affect the customer's balance due (because the Deposit already does), and it won't appear on receipts. The Total on the Transactions dialog will be blank to indicate that it doesn't figure in the balance due.

Note that only the "charged" amount can be applied, so for instance if there was a \$100 deposit followed by a \$75 charge, only \$75 of the deposit will be applied. The other \$25 is still available to be applied or transferred. Also note that there may be negative deposits applied in cases where a transfer is done or a refund is issued, so that the total deposit applied is kept in balance (in terms of how it affects the total deposit account balance).

Payment Transfer and Deposit Transfer

Payment and Deposit transfers allow money to be moved from one customer or reservation to another. In most respects this is identical to entering a negative payment in one place and a matching positive payment in another place. For more information, see the section on Transferring Deposits and Payments.

Credit

Credit transactions are for miscellaneous credits toward an account. This is most often used for coupons or promotions that aren't a monetary payment, but reduce the amount of monetary payment needed. They are treated like a discount in most respects, as they have a Transaction Category but don't have a Payment Method. One distinction from Discounts is that Credits are not automatically taxed like Discounts are. The description should be used to describe the purpose of the credit (bad weather allowance, credit for helping with mowing, etc.), and the description will have a "Credit : " prefix on receipts. Also note that credits are shown in a separate section on receipts, below the sub-total for charges and discounts (and taxes).

Refund

Refunds are essentially negative Payments. They have a Payment Type (how the refund was paid to the customer), and have "Refund" as the category. The description defaults to the payment method but can be changed to show the reason for the refund. You can just enter the amount in Each, or you can use Qty/Each to show more detail and have the total calculated (e.g. 3 days at \$20/day).

Note that even though Refunds are negative payments, the value entered should be positive since it's subtracted from payments. Also note that it won't allow you to enter refund unless there is a credit balance due to the customer. If you're refunding something that has already been charged, you need to add negative charge transactions first (or a credit) to indicate the merchandise or services "returned", so there is a negative balance due. Then add a refund transaction to represent money actually refunded to the customer.

Memo

This is not really a transaction, but just a note that will show up on the Transactions list and optionally printed on receipts. You can add a memo any time you want to explain the reason for a charge, credit, refund, etc., and it will be saved like any other transaction. Memos are not be printed on customer receipts by default, but you can make it printable by checking the option when you enter the memo. While the memo descriptions can technically be any length, they should be kept short to avoid pushing the Each and Total columns over. If necessary, just add multiple Memos.

If you need to change a memo from non-printable "Memo" to a printable "Print Memo" (or vice-versa), click on the Category field for the memo. A drop-down selection will let you change the memo type.

Expense

Expenses are never associated with reservations or customers. They are individual entries for campground expenses. You can set the category, payment method, description, reference, qty and amount each to whatever you like. You can also enter detailed Notes (a better place to put long descriptions so that reports are formatted better).

Misc. Income

Misc. Income transactions, like Expenses, are never associated with reservations or customers. They are meant to be individual entries for other campground income not recorded elsewhere, such as vending machine income, dump fees, etc. You can set the category, payment (receipt) method, description, reference, qty and amount each to whatever you like. You can also enter detailed Notes (a better place to put long descriptions so that reports are formatted better).

Deposit Adjusted, A/R Adjusted

These transactions are only used when applying an adjustment to the deposit balance or accounts receivable balance (running totals kept within the program). They don't appear on most reports since they don't affect charges or receipts, and are only a factor in bookkeeping.

Recommended Transaction and Reporting Procedures

There are probably as many different ways of handling transactions and requirements for reporting as there are campgrounds, so we've made Campground Master as flexible as possible. However that can also lead to confusion as to what the "best" method is. Here we attempt to outline the recommended procedures for getting the best results from Campground Master's transaction handling and reporting.

The details on *how* to do the various functions are covered elsewhere -- this will be just a basic outline of when to do what, and why.

Note: The examples below primarily apply to short-term reservations. Some details will be different for long-term (e.g. Monthly/Annual) reservations, although many of the same concepts apply.

Advance Deposits, Charges, and Confirmations

The "Deposit" transaction in Campground Master is intended only for "Advance" deposits, i.e. prior to their stay. This should be used when the customer has made a payment but you don't want the amount (or at least not all of it) to show as earned income on reports. For instance, lets say they make a 4-day reservation for next month, and you take a 1-day deposit or perhaps payment for the full 4 days. Depending on your accounting practices (and/or local laws) you may not want any of that deposit to be considered income yet (especially if it's fully refundable), and most certainly don't want the entire 4 days to be considered income since you haven't been paid for it yet.

Optionally, Deposit Definitions can be set up so that the amount of deposit required can be filled in automatically when entering the Deposit, whether it's through [Reservation Transactions](#) using the Deposit button, or when Guaranteeing and continuing to [Enter a Deposit Transaction](#).

Note: When we mention adding "charges" here, this also commonly includes Discount and Tax transactions in addition to Charge transactions. It's usually done with Select Rates so that you're using your Rate definitions -- however it could also be automatic through Auto-Rates or you could be adding Charge/Discount/Tax transactions manually.

Note: Don't confuse "Advance Deposit" with a "Security Deposit" (e.g. for loss & damages). Security Deposits are simply another type of Charge -- see the Security Deposits section for details.

Avoiding any of the Deposit being considered as earned income immediately:

In this case the only transaction you should enter is the **Deposit** transaction, for whatever amount needed. No charges should be entered yet -- otherwise the Deposit will be "Applied" and will therefore be categorized as income. So, how do you handle that? There are 2 completely different options available now:

Standard method

First you will probably need to know how much Deposit should be taken, if it's not an easy fixed amount. One way to do that is to use the "Check Rates" function while you're still in New Reservation. You can select a single day to calculate for, if that's what you need to know, or at least just look at what the daily rate is. Another way is to use "Quote/Confirmation" from Reservation Details. (Some of the details depend on whether you're using Auto-Rates, covered elsewhere.)

Next you need to enter the actual Deposit (which is basically a Payment, but treated specially). This can only be done in Reservation Transactions. Add the amount of Deposit (which should be the only Transaction you see at this point, until they check in).

Now you may want to print or E-mail a confirmation letter. That can also be done from Reservation Transactions -- but if you want to include the total amount for the stay (and perhaps the balance due), then you should use Quote/Confirmation (so you may need to back out of Reservation Transactions to Reservation Details, then click Quote/Confirmation). The difference is that the charges added in Quote/Confirmation will only be shown temporarily so you can create the confirmation, and won't be saved as income. Again, you don't want the reservation to have charges yet, or else they will be counted as income. So once you've entered the charges in Quote/Confirmation, then you can print or E-mail a confirmation showing the charges and balance, then click Done -- the charges will be removed so you're left with just the Deposit again.

Alternate methods (as of version 10) -- Post-dating Deposit Applied and Charges

What is described above is the original way of doing things to avoid counting the deposit as income -- add the Deposit only, and don't add charges until check-in. As of version 10, however, there is a completely new option available to automatically "post-date" the Deposit Applied and optionally even the Charges, so you can still add the charges immediately (either manually or through Auto-Rates) without then appearing on any reports until the reservation is actually checked in. You will see the transactions on the reservation (in gray text to indicate post-dating) and the post-dated transactions will on receipts and confirmations by default (see *Printing Receipts* for a way to avoid showing them on receipts), and they still affect the reservation's balance. However in terms of reporting they don't exist yet, so they won't count as "income" yet.

There are a couple primary advantages to this:

1. If you're not using Auto-Rates, but need to show the charges on a confirmation (or to calculate a Deposit amount), the Standard method requires you to enter the charges twice -- once when making the reservation, and again when they check in. Sometimes it might even come out differently. Using post-dated charges, you can enter the appropriate charges when they make the reservation and they will be "saved" until check-in. No more double-entry or worrying you might forget what you charged them.
2. The Deposit and Confirmation procedure can be streamlined. Instead of going to Quote/Confirmation to get the total amount first, then New/Edit Transactions to enter the Deposit, and then maybe even back to Quote/Confirmation to print or E-mail a confirmation letter with the charges showing, you can do it all in one place. No matter whether you start in one or the other, you can enter the charges and the Deposit all at once (assuming you also enable the option to save transactions done in Quote/Confirmation).

Now there are actually a few different options for post-dating as well. (See Program Options / Transactions for setting this up.) All of them keep the income off of at least some of the reports, but which configuration you choose may depend on your preferred reporting and reservation entry procedures. In the examples below, we're assuming you make an advance reservation, e.g. take a reservation in May for an arrival in July, and

take a Deposit for it. They also assume that you're adding the Charges immediately when you take the reservation (or at least need to see what they will be), since there's usually no reason to post-date if you wait until Check-In to add the Charges anyway, or use Auto-Rates to do that, and don't need to know what they will be for the Deposit amount.

Method 1 -- Only post-date the Deposit Applied. With this method, charges will show the date they're added, but the Deposit Applied is post-dated. So the charges will show immediately on "Charges by Category", and would be exported to QuickBooks if you use that function. They would still show as A/R until the check-in date. However the "Receipts by Category" report would show only the Deposit until after check-in, when it would finally be moved to the appropriate categories. You can also choose whether they appear on the Shift Report if you're using that functionality.

Method 2 -- Post-date both the Charges and the Deposit Applied, but Quote/Confirmation transactions are still temporary. With this method, charges will also be post-dated. So the charges will not show on "Charges by Category" or "Receipts by Category", as if they have not yet been entered (as if using the standard method above to not enter charges yet). Again, you can also keep them off of the Shift Report if preferred. However, if you want the charges saved and you're not using Auto-Rates, you need to enter them through New/Edit Transactions rather than Quote/Confirmation. You would still have the option to use Quote/Confirmation if for some reason you wanted to experiment or otherwise give a temporary quote without making any real transactions, post-dated or otherwise.

Method 3 -- Post-date both the Charges and the Deposit Applied, and Save Quote/Confirmation transactions. As with method 2, charges will be post-dated and will not show on "Charges by Category" or "Receipts by Category". Again, you can also keep them off of the Shift Report if preferred. However, in this case Quote/Confirmation acts almost exactly like New/Edit Transactions -- you can enter Deposits, Memos, etc and it's all saved along with the (post-dated) charges. Quote/Confirmation still has a useful difference, though -- it has a different default receipt format (usually the Confirmation Letter), for instance.

Changing options/methods -- if you decide to change which options/method you want to use, it will only affect transactions added after that point. It will not automatically go back and make all charges for future reservations post-dated, for instance, or vice-verse.

Note: Deposits, Memos, Payments, Refunds, and Transfers are never post-dated no matter what options you choose or where you enter them.

Making post-dated transactions "real"

Post-dated transactions will automatically become "real" transactions when a reservation is checked in or canceled. If necessary, the date will be adjusted to the current date at that time, which may be different than the original check-in date of the reservation. This cannot be undone.

They will also become "real" if you manually change the date for some reason, regardless of whether you change it to a past or future date. Even if a transaction's date is changed to the future, it's not considered "post-dated" for purposes of reporting (but may still show gray on the reservation's transaction list).

Counting the Deposit as earned income immediately:

Now let's assume you do have to count the **Deposit** as earned, since you have to pay the state & local taxes on it (or perhaps it's non-refundable). While this is not commonly the desired situation, it's actually the easier method.

In this case you would enter the Deposit as above, but you would go ahead and add the charges through Reservation Transactions, and print or E-mail the confirmation from there. The Deposit would be fully Applied immediately, and for reporting it would automatically be categorized proportionally to the categories charged (more on that in the Receipts by Category documentation).

Finalizing Charges and Payments (Check-In)

At the time the customer Checks In, their reservation will generally only have a Deposit transaction or possibly a Deposit and the Charges, as described above. Now you would add any remaining charges (or adjustments due to last-minute changes), and final payment. That's done through Reservation Transactions of course. After all charges/adjustments are added you will probably have a balance due -- so then you would add the Payment transaction.

Make sure you always add the charges **before** the Payment -- otherwise the payment will become "uncategorized" on reports (more on that in the Receipts by Category documentation).

So now the reservation should be fully charged and paid, and will have a \$0.00 balance, and checked in. You're done until they Check Out.

Handling Balances After Check-Out (or Cancellation)

Things don't always go so smoothly, and you end up with the customer owing money, or with you owing them a refund for an overpayment. This could be after check-out, but could also be due to a cancellation, or any time during an extended stay.

If they owe you money that you don't expect to ever receive, then you need some way to zero that out. The recommended method is to simply Reverse the Charges or enter Discount transactions to return the balance to zero. Also see the Bounced Checks information.

If you owe them money and you give them a refund, then that's simple enough -- see the Refunds section for details.

If you owe them money but you want to hold that for a future stay, then the way to handle that is with a Payment Transfer or Deposit Transfer (see that section for details).

Reporting -- Cash Basis

This is the most common reporting done. You should use the Quick-Reports "Receipts by Payment Method" and "Receipts by Category". You will probably not need any of the other transaction reports. Note that for sales tax reporting, do **not** use "Taxes by tax category" since that's an accrual-basis report. Instead use "Receipts by Category" and look at just the Tax categories. See "Taxes Setup" in the *Maintenance Functions* chapter for setup and reporting procedures.

Reporting -- Accrual Basis

If you do reporting on "accrual" basis, i.e. you want to count any Charges on accounts to be considered Accounts Receivable, you should use the Quick-Reports "Receipts by Payment Method" and "Charges by Category". You will also likely use the "Accounts Receivable" report, and you can use "Taxes by Tax Category" for sales tax reporting. See "Taxes Setup" in the *Maintenance Functions* chapter for setup and reporting procedures.

For more details on transaction reporting, see the Transactions tab view information.

The Transactions Dialog

Using the Transactions Dialog

This section goes into detail for the Transactions dialog, once you get to it. For the basics of how to get to this dialog, refer to the Transactions topic in the *Working with Reservations* chapter.

No matter how you get to the Transactions dialog, it will already show any previous transactions for the reservation, customer, or previous unbound transactions in the same session (see those sections for details). These will be shown in the transaction grid on the dialog, and will have a white background to show that they are old transaction. Any new transactions entered will be shown with a light yellow background.

Viewing More Details

If you need to see more details about the transaction, hold the mouse over the Type or Total for the transaction. A pop-up tip will show the date and time it was made, the operator it was made by, and any reference or payment method information. For more details, or to edit details like the reference information, click the Show Details checkbox located above the right side of the transaction list.

You can also check the Show Dates checkbox to show the date, which appear in the 2nd column. This option will be remembered once you set it, so you can set it once to always show the date. You can also edit the date if needed, e.g. to correct entries or back-date payments that were taken before using Campground Master, provided you have a high enough operator access level.

Adding Transactions

To add transactions, simply use the buttons to the left of the transaction grid -- either use the Select Rate(s) function, or select an individual transaction such as Charge, Payment, etc. You can also use the keyboard shortcuts (**Alt-S** for Select Rates, **Alt-A** for Charge, etc.). If you have Auto-rates enabled, there will also be a button to auto-calculate rate charges -- just click that button to calculate all of the appropriate charges for the reservation.

P.O.S. note -- If you have purchased the Point of Sale option, a P.O.S. button will be present at the top (near the Done button). You can use that button (or press the **F4** key) to access the point of sale function to enter merchandise sales into a reservation or customer's transactions. After the P.O.S. transactions are entered, just click Done on the Point of Sale dialog to get back to here -- all of those transactions will be added to the transactions here. Then you can enter payment and print a receipt for everything at once.

Payment Method

The default is to not show a payment method selection field on the Transactions dialog, since it can be selected when you use the Payment button anyway. Therefore you may not see this selection field on the Transaction dialog. However you can show a Payment Method selection field here so you can select the method before entering the payment. See Maintenance / Program Options / Prompts to enable this field.

Discount Used

If you have previously used a discount for this reservation/customer, or if the customer has a discount defined, that discount selection will be pre-selected for your convenience. Otherwise, you should select the discount used by the customer before selecting rates.

Setting the Paid-Through Date

Any time a payment is made for reservations, you should verify that the reservation's Paid-Through date is updated appropriately. To set this date, click on the Paid-thru field for the reservation in the top grid. This is discussed further in the *Reservation Transactions* section.

Selecting Rates

For site rentals and many other common transactions, you will probably have a number of Rates defined to speed the entry process, and to avoid mistakes that can occur if you had to enter the value each time. In fact this will probably be the most often used function in the Transactions dialog.

For more details, see the *Selecting Rates* section.

Entering Individual Transactions

Even with comprehensive rates definitions, you will probably enter most payments and deposits as individual transactions, as well as the occasional special charge, credit, refund, etc. See the *Transaction Types* section for a description of each type.

For more information on manually entering individual transactions, see the Entering Individual Transactions section.

Temporary Operator Override

If you're in the Transactions but you're unable to complete a function due to your Operator Access Level, you don't necessarily have to go all the way out to have a manager log in. Just right-click in the caption bar, and select "Temporary Operator Override". That will allow someone to log in for this function only -- after leaving this dialog, it will revert to the previous operator automatically.

Issuing Refunds

If you need to issue a refund to a customer, there's a recommended procedure to keep things in balance. You must first reverse the charges to offset the charges for which you want to give a refund (e.g. for days not stayed or merchandise returned), and then enter a Refund transaction. This will allow the transactions to balance out. See the Refunds section for more details.

Deleting Transactions

Assuming you're logged in with a sufficient operator Access Level (Manager by default), it's very easy to delete transactions, both old and new. While this is handy if you click on the wrong transaction type button when adding transactions, it can also be a dangerous thing. To delete a transaction, all you need to do is click on any part of it in the grid and click the Delete Selected Item(s) button. You can delete multiple items at once as well, using **Ctrl**-click or **Shift**-click to select multiple lines.

You will get one warning prompt, so be sure to answer "No" to the prompt if you don't mean to delete anything. In particular, old transactions can be deleted just as easily as new ones, and you cannot get them back using the Cancel button.

Note: If you want to give the customer a credit or refund, **don't** just delete transactions to do it! This can result in incorrect reporting, and of course gives no indication of what transpired. It's better to use the refund procedure described above.

Old transactions (any that were added in a previous shift or previous day) can only be deleted by Manager-access operators. In addition, auto-rate transactions cannot be deleted without manager access once the reservation is checked in. If you need to clean up auto-charges, you can undo the check-in (from the Reservation Details dialog), delete the charges, and then check it back in.

Reversing Charges

If any Charges, Discounts or Taxes are selected in the grid (and **only** those types), a "Reverse Charges" button will appear at the bottom. Click this button and it will add equivalent transactions with negative amounts, effectively reversing those charges in one step.

Editing Category Allocations

If the option to allow category allocation for payments is enabled (Maintenance / Program Options / Prompts), and assuming you have sufficient access to edit transactions, then this button will appear whenever a single Payment or Refund transaction is selected. This can be used to manually change the allocation of the payment to specific transaction categories. While this is not usually necessary, your particular accounting needs may require it. See the Payment, Deposit, and Refund Transactions section for more details.

Transaction Details

Normally the transactions list just shows the basic information -- type, category, qty, description, and amounts. However it's sometimes useful to refer to other information, particularly for seeing the dates, reference info and other details of prior transactions.

To see the dates of the transactions, check the Show Dates checkbox above the list (below the Cancel button). To see more details for the transactions, check the Show Details checkbox. New columns will be added to the list for all of the other details (you will probably need to scroll to the right to see them). These include the Payment Method and Discount Used (when applicable), Check # / Reference, the time and operator when it was made, a Receipt #, reservation date (if applicable), and Shift (if enabled). The Receipt # is an internal number assigned to each transaction session (only one transaction added after version 1.2 of the program will have a receipt #).

If you have Manager access, you can edit some of the data (Check #/Ref, Payment Method and Discount Used). If you have Administrator access, you can also edit the date, time, and Receipt #. The Operator and the Reservation date cannot be changed.

Transaction Color Coding

Some color-coding is used for the entries in the Transaction dialog, to aid in spotting certain types. Since all new transactions for the current session are yellow, the real color coding only applies to "old" transactions.

Any auto-calculated transactions will be shown in blue. This helps distinguish charges that were not part of the auto-rates calculations (e.g. manually added charges), and also indicates that those charges cannot be deleted once the reservation has been checked in (except by a manager). If auto-charges need to be re-done, you need to undo the check-in, delete the auto-charges, and then check it back in.

Any payments, deposits or transfers "in" to the reservation will be shown in green (assuming they are positive amounts). Any refunds, transfers out, or negative payment/deposit values will be shown in red.

Memo transactions will be shown with either blue or red text -- printable memos will be shown in blue, non-printable memos in red.

All other transactions will be shown with the normal white background. If you're using auto-rates, a typical reservation will have only blue and green transactions (auto-charges and payments), possibly with a white Deposit Applied transaction and perhaps white Memos.

Open Cash Drawer

If you have a cash drawer installed (and set up through *Maintenance / Cash Drawer Setup*), then there will be a button to Open Cash Drawer. You can click this any time to open the cash drawer, assuming your operator access level is high enough according to the Access Levels setup (by default, all Clerks can do this).

In addition, the cash drawer can be configured to open automatically when you print a receipt, provided there was some kind of payment received or refund issued that would require the drawer to be opened (so just re-printing a prior receipt or invoice won't open the cash drawer).

Note: If you're not planning to enter transactions but just need to open the cash drawer, a quick way to do this is to open a Transactions window (e.g. click on the cash register icon or press **F4**) and then click the Open Cash Drawer button.

Send E-mail Form / E-mail Confirmation

If you have the SMTP Setup completed, then this button will be shown. Just click this to send an E-mail confirmation, receipt or other defined custom E-mail form to the customer (using the currently entered transactions -- note that this may be different than the result from Quote/Confirmation if charges have not yet been added). Note that if you have more than one Form defined as an E-mail type form, then it will show a list of these forms allow you to select the one you want to send.

Print Window Tag

If the option is enabled to show this button, then you can simply click the button to print a window tag. Unlike the other printing functions, this won't show a preview or print dialog -- it will immediately print the tag without further prompting. See *Maintenance / Program Options / Functions* to enable or disable this button. Note that if more than one linked reservation is shown in the reservation grid at the top of the dialog, then you can print tags for individual reservations (sites) by selecting a reservation in the grid before printing the window tag.

Finishing Up Transactions

When you're finished entering transactions, you may want to print a receipt (which is also commonly used as a reservation ticket for the office files), or you may be finished and ready to move on. Obviously you can just click one of the Print buttons to print a receipt, or Done if you're finished, or even Cancel if you don't want to save any of the new transactions.

First it should be noted that there are two separate things happening on this dialog -- the transactions and the reservation information. If you change any of the reservation paid-through date(s) at the top, those must be saved as well as the new transactions. So remember this if you click Cancel. The software will ask you if you want to abandon "changes" if you have made any date changes, or if you want to abandon the new "transactions" if you or added transactions, so you will have a pretty good clue as to what would be canceled. But if you made both date changes and added transaction, then it will only ask about the new transactions.

Now, assuming you are done and/or want to print a receipt, some validation will be done before continuing. For example, it will not allow any transactions without an Each amount. (It will warn you and move the cursor to the transaction amount that needs to be filled in.) It will also check to make sure you have selected a Pay Method if you have any transactions that need one, and a Discount Used if there are any Discount transactions

For more information on printing receipts, invoices and letters, refer to the *Printing Receipts* section.

Recalling Transactions

There may be times when you want to see what you just did, after closing the Transaction dialog. To bring it back up, use "Edit the Last Transaction Viewed" under the Transactions menu, or simply press **Ctrl-T** on the keyboard.

To bring up other transactions, you can locate the customer or reservation related to it and get to it from there, or you can go to the Transactions tab view. The Transactions tab view shows all transactions for the day by default. If you want to bring one up in the Transactions dialog again, just locate it in the list, right-click on it, and select Transactions.

Shortcut Keys

The following function keys can be used as shortcuts:

- F2** - Select Rates (or Auto-Calculate, if the auto-calculate button is present)
- F3** - Enter Deposit
- F4** - POS Sale (if POS option is present)
- F5** - Enter Charge
- F6** - Enter Cash Payment (Enter Payment, automatically selects Cash)
- F7** - Enter Credit Card Payment (or Other Payment if credit card processing is not enabled)
- F8** - Print
- F9** - Open cash drawer
- F10** - Done

Auto-Rates

If properly configured, auto-rate calculation can take rate selection even further than Selecting Rates, by making it a 1-click or even a no-click operation.

Depending on the Auto-Rates Options (Maintenance / Program Option), you may or may not see an Auto-calculate Rate Charges button on the Transaction and Select Rates dialogs. Auto-rates are disabled by default, because the rates must be set up very carefully for it to work properly. (See the Auto-Rates Setup section for details.)

If auto-rates are enabled, then they can also be set to automatically be added when a reservation is created or checked in. In either of these cases, charges become fully automatic and the Select Rates dialog may never be needed except for special cases.

If it's not set up to be fully automatic, then you can still click the Auto-calculate Rate Charges button on the Transactions dialog to instantly add the appropriate rate charges. This eliminates the need to go into Select Rates, pick the rates that apply, and so on. They will be added directly in the Transactions dialog as new charges.

Recalculating auto-rates

When changes are made to a reservation such as extending the stay, the charges usually need to be adjusted.

You can set the option to automatically recalculate rates whenever there is a change, but that could result in a lot of rate adjustments and re-adjustments when "tinkering" with a reservation (this may depend on how many different add-ons affect your rates). It may be better in some cases to leave the re-calculation disabled, and make sure the staff is trained to use the "Auto-calculate Rate Charges" function on the Transactions dialog whenever changes are made. If the Auto-calculate function is used and the rates are already correct then it won't change anything, so it never hurts to double-check it. (Note: This assumes that the "Credit & add only charges that have changed" option is used for recalculating rates -- other options can result in a lot of redundant adding & removing of charges.)

If it's recalculating when you don't want it to for a particular reservation, e.g. due to a special circumstance, then you can stop the recalculations by checking the "Disable automatic rate recalculations" option in the Reservation Details.

Note that once a reservation is checked out, it will no longer recalculate automatically. This prevents later rate changes from affecting old reservations accidentally.

Linked Reservations

As with the manual Select Rates function, rates are automatically calculated for linked reservations if they are synchronized or sub-members. Likewise, you need to be aware that if the reservations are made non-synchronized later, then the rates need to be recalculated for **both** the original master reservation and the non-synchronized reservation. The charges for the linked reservation will be removed from the master, and added to the non-synchronized reservation. If necessary, you can transfer part of the payment from the original master reservation to the non-synchronized reservation so that the master still balances out, and then a payment or refund can be added to the non-synchronized reservation to make up the difference due to the changes.

One way to avoid some of the issues above is to avoid using non-synchronized whenever possible. For instance if a reservation that's synchronized needs to be checked out early, change it to a sub-member instead of non-synchronized. That way the billing is still combined, and only affects the master reservation.

Deleting Auto-Rate Charges

To prevent "rate tampering", auto-rate charges cannot be deleted without a Manager operator access level once the reservation is checked in. If a mistake is made requiring that the rates be removed (e.g. the reservation is checked in by mistake, or a mistake is made that will look too confusing if an auto-recalculation is done), then you must undo the check-in to make the reservation Pending. This can be done from Reservation Details by unchecking the "Checked In" box. Then you can delete the auto-rate charges (which will be in blue). They will be re-added appropriately when the check-in is done again (assuming that's the auto-rate option you're using), or if the Auto-calculate Rates function is used again.

Entering Individual Transactions

Overview

Even with comprehensive rates definitions, you will probably enter most payments and deposits as individual transactions, as well as counter sales and the occasional special charge, credit, refund, etc. (See the Transaction Types section for a description of each type.)

Prompt-for-Details vs. Grid-Entry

There are two different ways transaction information might be entered, depending on the "Prompt for details when entering transactions" option setting in Maintenance / Program Options / Prompts. This option is selected by default, which means that whenever you click one of the transaction-type buttons, a dialog will open for entering the transactions. This is the most user-friendly method, and allows more information to be entered. The option to not use these prompts is really only there for backward-compatibility, since early users of the software may be used to the grid-entry method. The prompt-for-details method will be discussed here, but a section on the grid-entry method appears below for reference.

To enter an individual transaction, just click the appropriate transaction-type button to the left of the transaction table. As soon as you click the button, a dialog will appear with selections and/or fields for entering the data. These dialogs are detailed below.

Regardless of which method is used for entering transactions, you can edit or delete individual transactions in the grid. Just double-click on any cell in the grid to edit it, or click once to select the cell and start typing (what you type will immediately replace the current text). The only things you can't change are the Type (determined by the button you clicked) and the Total (calculated by the software). Those are shown in gray to indicate that they can't be edited.

Generally only the "new" transactions (those added during this dialog session) can be edited or deleted. The old transactions from previous dialog sessions can be edited or deleted only if you have Manager access or above.

Charge, Discount and Credit Transactions

Charges and Discounts are essentially the same thing, except that a discount is treated as a negative charge, and must have a "Discount Used" associated with it. The typical use for Discount transactions would be for discounted rates or items, for which you would enter the normal price as a Charge and then add the Discount as a separate transaction. This is helpful both for reporting and tracking discounts given and also for indicating the amount of discount on the customer's receipt.

Credit transactions are similar to Discounts in that they are basically negative Charges, but there are a couple important differences -- Credit transactions cannot be automatically taxed, and they don't have a "Discount Used" associated with them. Credit transactions are typically used for things like coupons (which don't usually reduce the sales tax, for instance), or for other special credits to a customer like that have nothing to do with using a discount club. Also, Credit transactions will appear on the receipt in a separate section below the sub-total for charges, discounts, and taxes.

Enter Charge Information

When this dialog opens, focus will be in the Transaction Category list. You must select an appropriate category for the charge (using the up/down arrow keys or the mouse), then you can press **Enter** or **Tab** to move to the description field.

Note that the description will automatically default to the name of the category you selected. You can leave it at this or change it to whatever you like. It's recommended to keep descriptions fairly short so that they fit on the receipts, since there is a limited amount of room. The text size on the receipt will be shrunk to make it fit, but it can only shrink to a certain size, and it doesn't appear professional when one long entry is in smaller text than all of the others.

Also note that if you change the description then you should eliminate the existing text because the category may still appear on the receipt (depending on an option set in [File / Printing Options](#)). For instance, if you change the description of a Gift Shop charge, don't leave "Gift Shop" in the description. Make it something like "Flower Basket", and the receipt will show either "Flower Basket" or "Gift Shop: Flower Basket", depending on the printing option.

Next you will enter the Quantity and the Each dollar amount. When entering dollar values, you don't need to enter the dollar sign (\$) -- it will be added for you. Also note that the Quantity can be any number, including decimal numbers like 1.75. You can also choose to leave the Quantity blank, and a single quantity will be assumed.

Finally, you need to select the taxes that apply. Any taxes selected here will result in automatic Tax transaction entries, so you don't have to enter taxes manually. If default taxes have already been set up in the Taxes Setup, then the default taxes will already be checked according to the Category selected. Make any changes needed, then click [Save](#) (or you can use **Ctrl-Enter**, or just press **Enter** repeatedly until it gets to the Save button and then it will save the charge.)

When completed, you will see the Charge transaction and possibly one or more Tax transactions appear in the Transaction dialog. If the reservation had an unapplied Deposit transaction, you will also see a "Deposit Applied" transaction inserted, which simply indicates that the deposit has now been applied to charges.

If you made a mistake and need to make changes, you can either Delete the new transactions and do the Charge again, or just click on the field in the grid that needs to be corrected and enter the new value. be careful about making changes, since the Tax will **not** be re-calculated! If an amount needs to be changed, it's best to Delete the Charge and all associated Tax transactions, and then re-enter the Charge so it recalculates the tax.

Don't worry about having multiple tax transactions when you're entering more than one charge or discount -- they will be combined on the receipt so only one tax transaction appears, provided the "Combine taxes" option ([File / Printing Options](#)) is selected.

Enter Discount Information / Select Discount Used

The main difference when entering a Discount transaction is that when you click the Discount button, if you haven't already selected a "Discount used" on the Transaction dialog then a list of discounts will be shown to choose from. (If the reservation or customer used a discount previously, it will already be selected so you don't have to select it again). Just select the appropriate discount (with the arrow keys or mouse) and click [OK](#) or press **Enter**. You can also double-click the discount to do it in a single step.

Then the same dialog will appear as for Charge transactions, described above. Note that you can select a category just like Charges, or you can select the generic "Discount" category. This is up to you, and only affects reporting. We recommend selecting the same category as you did for the charge corresponding to this discount, so you can have more detailed reporting.

The Description will default to the Discount Used, rather than the category. This can also be changed if desired, but it looks best on receipts to show the type of discount used.

Make sure you enter the "Each" amount for the discount as a positive value -- it will be subtracted from charges, but the entry must be made as a positive amount. For instance, just enter "5" to give a \$5.00 discount.

Alternatively, you can enter a discount percentage (e.g. enter "10" for a 10% discount) and the amount to be discounted. The program will calculate the amount of the discount for you. The "of" amount to be discounted will default to the amount of new charges added this session, but you can change it if needed. You can also select any Charges already added and those will be used as the "of" amount to be discounted.

Corresponding Discount and Tax transactions will be generated as they are for charges.

Note that Discount transactions will be shown on receipts with a "Discount : " prefix in the description, unless the description already contains the word "Discount".

Enter Credit Information

Entering a credit is just like entering a Charge or Discount. However you won't be prompted for a Discount Used, and there will be no tax selections. Just select a category (which defaults to a generic "Credit" category, but you can change it), change the description if desired, and enter the Quantity (if > 1) and Each amount. Again, the amount should be entered as a positive value even though it will be subtracted from the charges.

Note that Credit transaction descriptions will always be prefixed by "Credit : " on the receipts, and they will appear in a separate section below charges and discounts.

Tax Transactions

Taxes are usually handled automatically when selecting rates or entering charges. However you may have an occasional need to enter a tax manually.

To enter a manual tax, just click the Tax button on the Transactions dialog. This will open the Enter Tax Information dialog. (If no Tax Rates are defined for the database, there will not be a Tax button.)

Enter Tax Information

First you will select a tax category from the list. When you select a category, notice that the Tax Rate shown will automatically change to the rate defined for the taxes. When you have the tax category selected, just press **Tab** or **Enter** to jump to the Amount field. If there were any charge or discount transactions already entered, the amount will already have the total assumed to be taxed. If this is correct, just click Save. If you need to adjust the amount to be taxed, just enter it and then click Save.

The tax transaction will be added to the Transactions dialog. Note that Tax transactions are handled differently in that the "Qty" field is actually the dollar amount to be taxed, and the "Each" field is the tax rate. This won't affect the way you enter the tax with this dialog, but be aware of this when you are looking at the entries in the grid.

Payment and Deposit Transactions

Payments, Deposits and Refunds are all entered exactly the same way. The only difference you will notice is the default in the Amount field when the dialog opens.

Enter Payment Information (or "Enter Deposit" or "Enter Refund")

First you should select a Payment Method from the list. If a payment method was already selected for transactions (or if a previous payment transaction was entered), the previous payment method will already be selected. In addition, if credit card information was previously entered for any of this customer's transactions, or if you enter or swipe a credit card first, then the payment method type may be selected automatically. In that case, just press **Enter** or **Tab** to go to the Description field. Otherwise, use the up/down arrow keys or the mouse to select a payment method first.

Note that the Description will automatically default to the name of the payment method you selected. You can leave it at this or change it to whatever you like. It's recommended to keep descriptions fairly short so that they fit on the receipts, since there is a limited amount of room. Note that the description will always be preceded by "Payment : " on the receipt, so you don't need to repeat that. (Likewise, Deposits and Refunds will be prefixed by the transaction type on receipts.)

The Quantity field is usually left blank, but you may enter a quantity if you prefer. This might make sense for special types of payment like Traveler's Checks or campground membership coupons. Note that depending on the payment method, the Qty field may be disabled (this is configured in the Payment Methods Pick List). For instance, Cash, Check and Credit Card payments don't normally have a Qty, just an Amount. One notable exception is for coupon-type payments, which can be configured so that each coupon has a set value and only a Qty is entered.

The Amount to pay field will usually be automatically set to the customer's current balance (or credit balance if you're doing a refund), since most of the time the balance will be paid in full. Be sure to change this if needed. Note that if the "Trav Check" payment method is selected, it will change to Amount of checks and you will need to enter the amount of the travelers' checks received. If it's more than the amount due, you will then need to add a separate Refund transaction for any cash given back to the customer.

If you are accepting cash that's not exactly the amount due, you can use the Amount Tendered field to enter the amount actually received. This will calculate the change due and show it on the dialog. If the amount tendered is entered, it will also appear on receipts along with the change due (unless disabled through Maintenance / Printing Options), and is saved with the transaction (in the Reference field).

If the option is enabled to show a change-due prompt, then a pop-up message will also be shown when the receipt is printed. (See Maintenance / Program Options / Functions). For countries like Canada where the penny is being phased out, you can select the "Round to the nearest 5 cents" option, to show the proper rounded-to-the-nearest-nickel amount of change to give when a cash payment is entered and a "Tendered" amount is specified. The rounded amount will also show on receipts, however this does not affect the recorded total for the transaction or the amount of payment received for the transaction. Any discrepancies due to rounding will be minimal in the long run, and should be handled the same way as any other minor cash drawer imbalance.

The Ref / Check # field can be used for anything you like (or left blank). Most often this is used for a check number. If it's a Check payment type (as configured in the Payment Methods Pick List), then the number entered here will automatically be added to the description for the receipt. If you don't want it there, then you can go back to the description field and change it before clicking Save.

Note that the Ref / Check # field does not show on receipts, so it is private. You can view it later by checking the "Details" box on the Transactions dialog, and it will also appear in the Detailed Transaction reports. Also note that this field is enabled according to the flag for each payment method, set up in the Payment Methods Pick List. So if it's not enabled and you think it should be, check the pick list settings.

For further information about credit card transactions and processing, see the next section: ***Credit and Debit Card Payments***.

Applying Payments to Categories

If the option to allow category allocation for payments is enabled (Maintenance / Program Options / Prompts), then a list of categories will appear in the lower left of the payment dialog. This functionality is useful if you use the Receipts by Category report and need to manually allocate categories to overcome interpolation issues (for instance when payments are made in advance, or if monthly reservations are not paid in full each month).

You can leave the default "<AUTOMATIC>" option selected in most cases, e.g. whenever a bill is paid in full, since it will automatically split the payment among the appropriate Charge transactions. However if you need to manually apply the payment to one or more specific categories, rather than letting it divide it proportionally among all unpaid charges, then you can either select a single category for the payment or click the "Split Categories..." button to enter multiple categories with an amount to allocate into each category.

If you need to change the allocation later, then you do so by selecting the payment in the Transactions dialog -- an "Edit Category Allocation" button will appear to allow editing the allocations.

Note that Deposits cannot be allocated to categories -- they are always reported separately from payments. If the customer makes an advance payment that you want to report in specific categories at this time (e.g. as realized income), then it should be entered as a Payment, not a Deposit. However, once the deposit is applied (a Dep Applied transaction automatically added), then the Dep Applied transaction can be categorized manually if needed using the Edit Category Allocation function. Likewise, Payment Transfers can be manually allocated after a transfer is done.

Deposit Transactions

Note that Deposit transactions are used for "advance" deposits, i.e. payment before a stay, not to be confused with Security deposits, e.g. payment kept for possible loss or damage.

Entering Deposit Information

Deposits are entered the same way as payments, except that the Amount will not have a default value. Just select a payment type and enter an amount, and click Save.

Note that when you add a deposit, it's not "Applied" yet -- while it does show up on the customer's balance due (as a credit), it won't affect the overall A/R balance. It's added to the overall Deposits balance until it's applied. When a charge transaction is entered *after* a deposit, then a separate Deposit Applied transaction will be inserted to show that this deposit has been applied and is now earned income.

Automatic deposit amount calculation

Optionally, Deposit Definitions can be set up so that the required deposit amount can be filled in automatically in the "Amount of deposit". This can either be fully automatic, appearing as soon as the Enter Deposit window is opened, or it can leave it blank initially with an "Auto-set" button that will calculate it when desired. (See Program Options / Reservations to enable these options.) Depending on the Access Levels configuration and your operator level, you may or may not be able to change this amount once it has been automatically set.

Splitting the deposit among multiple reservations

If the reservation is linked to other **non-synchronized** reservations (for separate billing), then a special Split payment among group members option will be present when entering the deposit. (This option appears as a

checkbox next to the "Amount of deposit" entry field.) For instance, if one person is making a deposit for a group of 4 parties, select this option to automatically split the deposit (transfer 1/4 of it to each of the other 3 reservations). This adds all of the appropriate "Deposit Transfer" transactions, saving you the trouble of doing the transfers manually.

Important: You must enter the deposit on the "Transaction Master" reservation (Linked Master), and the other reservations must be linked directly to the master as Non-Synchronized.

Credit and Debit Card Payments

Credit card payments and deposits are started the same as other Payment transactions. When a Payment Method is selected that's recognized as a Credit Card (as per the Base Type in the Payment Methods Pick List), additional fields will be enabled, and Processing may be available directly in Campground Master if you have Credit Card Processing set up.

Credit Card Information

If the payment type is a credit card, you can enter the information here. If you have a credit card swipe attached, you can simply swipe the card and the fields will be filled in automatically (sometimes you need to put the text cursor in the Credit Card # field before swiping the card -- **Alt-C** is a shortcut to jump to that field). However if you're processing cards through Campground Master and use a chip (EMV) terminal, then you will likely have to click "Process card" (without entering the number) so the terminal is activated.

Note that if you do use a "simple" credit card swipe, you may need to adjust its "termination" or "Sentinel" settings and make sure the credit card processing settings match the number of tracks that the reader will read.

Even if you don't have Campground Master set up to process credit card authorizations, having the credit card information in the system can save time later, for instance the next time a customer calls to make a reservation and you need the credit card information to guarantee it. In fact, your operator access level may require you to enter credit card information for any appropriate payment methods.

Normally it will check any previous transactions or guarantees for existing credit card information, and automatically fill in the fields with the last credit card used. If they need to use a different card or if you want to swipe a card to make sure it's correct, you can click the Re-enter or Re-swipe button to clear the fields. You can also disable this automatic lookup through the option in Maintenance / Credit Card Security Setup.

Also note that the credit card information can be shown on the customer's receipts, with an optional signature line. You can also have it print a special credit card signature slip automatically when a credit card payment is entered. See Maintenance / Printing Options / Credit Cards.

In some cases, when previous card information is shown, there will be an Update Exp button to Enter Payment and Edit Guarantee dialogs, to allow changing just the expiration date without requiring the card number and name to be re-entered (as it would be with Re-enter or Re-swipe). Note that this is only an option if the full card number is known (even if it's shown as masked), so that new card information may be submitted. Therefore this will not be available if your configuration is not allowing the card information to be saved, or the information is not available due to swiping the card outside of Campground Master or using an EMV reader for processing.

Processing Credit Cards

If you have enabled credit card processing (and assuming that you have any 3rd-party processing software installed, etc.), then you can process the credit card right here on the payment dialog. This also assumes that your operator access level is sufficient for credit card processing. The program will not let you Save a credit card sale unless it's processed and approved successfully. If you find that it's not possible to get a payment approved, perhaps due to your Internet connection being down, then you should save the information and enter it later (or request that they come back, or pay with an alternate payment method).

Chip cards / EMV terminals

If you use a chip (EMV) terminal, e.g. from X-Charge or Cayan, then if you have a card present you will have to click "Process card" (without entering the number) so the terminal is activated and ready to accept the card. Note that there is no need to enter a CVV or address information for card-present transactions. Once the terminal is activated, follow the steps on the terminal to complete the transaction.

Manual card entry / keyed entry or simple mag swipe

After entering the credit card number, expiration date and optional name (or swiping the card successfully on a simple mag swipe), press the "Process" button to request authorization. With some processors (e.g. X-Charge), you can also click "Process" before entering the card information and let the processing software handle the rest. In fact, depending on the credit card Processing Setup options, the card entry fields may be completely disabled so you can only click Process.

You may see additional CVV2/CVC, Zip and Address fields below the credit card entry fields, depending on the processing options. These can be entered after swiping the card or before -- except that if the option is selected to immediately process the card after swiping, then you need to enter these before swiping the card. While these are always optional, you often save money on processing charges if this information is entered. If the transaction is for a customer with address information already entered, those fields will be filled in already. You can verify these with the customer and/or change them if necessary.

Processing Response

After you press the "Process" button, all other controls will be disabled except the Process button, which will now be an "Abort" button. Abort can be used (and should **only** be used) if you decide that the processing will not be completed due to a connection problem or processing software problem. Note that the Abort will actually just "request" that the process be aborted. If it appears that the processing software has already picked up the request and is in progress, it cannot really be aborted. It will eventually time out and return an error if the processing software does not respond. Not that it's still possible that the transaction goes through, in which case you need to adjust the time-out settings to allow for a longer delay.

Once processed, a response will be shown. If it's approved, clicking OK on the response will immediately close the Payment dialog. (There's also an option to skip showing the approved message so the dialog closes automatically.)

Debit Cards

Campground Master only supports debit cards with PIN# entry if using X-Charge XpressLink (see Credit Card Processing Setup). If it's a Visa or MasterCard type debit card, then it can still be processed just like a credit card if you like. Otherwise, you will have to use the processing software's own interface to process the debit card outside of Campground Master, then enter the payment in Campground Master separately.

If you are using X-Charge ExpressLink and have enabled debit card processing, then select the "Debit Card" payment method. Then you can enter a Cash Back amount here (if cash-back is enabled and you have

sufficient operator access), then click Process. X-Charge will prompt for swiping the card and entering the PIN number, and then will show the response (likely printing a receipt automatically as well). If a Cash Back amount was entered, it will be shown on the receipt as a "Cash" refund, so your reporting will be correct at the end of the day.

If you give them cash back and don't have the "Cash Back" option enabled, you should change the Amount Paid to be the total amount for the debit card payment, and then do a Refund transaction for the cash back (with a payment method of Cash selected) -- this way the amount of cash in the drawer and the total debit card charges will balance with the reports at the end of the day.

Forced Sales

There may also be a Force Sale button shown next to the Process button, which will allow you to force the authorization of the credit card sale. This should only be used if you have already received an approval card from a voice authorization. After pressing this, you will be asked to enter the approval code you received for the transaction. It will then submit the transaction to the processing software as a forced sale. This will usually be approved as long as there are no errors in the card number, etc.

Voiding credit card payments and refunds

After a credit card payment (or refund) has been processed and approved, it cannot be deleted without voiding the credit card transaction. To do this, you simply highlight it on the Transactions dialog and click Delete Selected Transactions as you would for any other payment. After a warning, a Void dialog will open with the credit card information, and you can submit the void transaction for processing. See "Voiding credit card transactions" for more details.

Refunds

Refunds are entered the same way as Payments (using the same dialog), except that the Amount will default to the *negative* balance due. This is because the balance due itself should be negative at the time you enter the refund, indicating that a balance is due the customer. If there is not a negative balance due, a Refund cannot be done. Thus the Amount shown in the Enter Refund window will actually be shown as a positive value, equal to the amount to be refunded. (Make sure you enter a positive amount here if you enter it manually.)

Point of Sale (POS) Refunds -- Returns for POS sales are done differently -- see the Returns section in the *Point of Sale* documentation for details.

Reminder: When you need to issue a refund to a customer for charges already added, there's a recommended procedure to keep things in balance. You must first enter "negative" charges to offset the charges for which you want to give a refund (e.g. for days not stayed or merchandise returned), and then enter a Refund transaction. This will allow the transactions to balance out.

The easiest way to enter the negative charges, if you are using version 8.0 or later, is to use the "Reverse Charges" button. If any Charges/Discounts/Taxes are selected (and **only** those types), a "Reverse Charges" button will appear at the bottom. Click this button and it will add equivalent transactions to the ones selected but with negative amounts, effectively reversing those charges in one step. (You still need to do the Refund function to show the money refunded.)

For users prior versions (before 8.0), or if you need to only reverse a partial quantity, entering a negative charge can be done either manually (use the Charge function and enter a negative *Quantity*, but **not** a negative *Each* amount), or by using Select Rates if it's a rental adjustment (select the rate and enter the number of days, etc. as a positive amount and Add it as usual, but check the "Invert Amounts" box before clicking Done).

After entering the negative charge transactions, the reservation balance should be negative so you can use this Refund function (click the **Refund** button) to enter the amount refunded.

Processing Credit Card Refunds -- If you are doing credit card processing through Campground Master, then you will usually want to process the refund as a credit to their card as well. By default, when you click the Refund button and the most recent Payment or Deposit transaction has credit card information, then it will automatically populate the credit card information from that payment, so the refund will be processed to that card. Note however that in versions after May 2019, this will also contain the "Transaction ID" of that payment which is required now by most merchants to process refunds. As a result, if the refund (or combination of refunds) is larger than the amount of that payment, you will get an error similar to "Exceeds sales cap".

Therefore you may need to select a payment other than the most recent payment to reference for the refund, possibly even doing the refund in multiple parts not exceeding the amount of each payment. To do this, simply click on the Payment (or Deposit) transaction that you want it to reference in the transaction list **before** clicking the **Refund** button (this requires version "10.0 rev.g" or later, otherwise it will always use the last credit card payment for reference, or possibly not use any reference at all). The credit card information from that transaction will be used. Note however that if the credit card has expired, then it cannot be used and may not appear. Likewise, if the customer's credit card from the original payment is no longer active, the refund transaction will fail, and you will need to refund the customer in some other way.

Refund Checks -- If you issue refunds by check, then you will probably want to add a new Payment Method called "Refund check" that you use for those, instead of just selecting "Check" as the payment method. This way it will show those separately on the Receipts by Payment Method report, for instance, instead of just subtracting them from the total of Checks received. See Pick Lists for adding the new Payment Method.

Voiding Credit Card Transactions

This section only applies if you have credit card processing enabled, so that the credit card transactions are processed through Campground Master. Otherwise, credit card payment transactions can simply be deleted like any other transactions (and with the same restrictions depending on your access level).

If you do have credit card processing enabled (and the Credit Card Processing Setup indicates that Voids are possible through your processing software), then removing credit card transactions requires that the transaction be Voided before it's settled with your merchant processor. After a credit card payment (or refund) has been processed and approved, it usually cannot be deleted without the Void procedure. To do this, you simply highlight that payment or refund on the Transactions dialog -- the button that's normally "Deleted Selected Item(s)" will change to "Void Selected CC Item", so click this button. A Void dialog will open with the credit card information, and you can submit the void transaction for processing.

Note that you might not be allowed to Void a transaction, or may only be allowed to Void it before the Transactions are Saved, depending on your operator access level.

Administrator note: In addition to the access level setting for voiding, the access level for "CC Processing - Delete (or Void if same day) 'old' processed transactions" must also be set appropriately. Otherwise the Void button will not be enabled for the operator because a Void also deletes the transaction.

The Void process is similar to processing payments -- it requests the void from the processing software, and shows a response. It can also be aborted if necessary.

If you've enabled the option to automatically print credit card slips, then a "VOID" slip will be printed when it's processed. However there's no way to print one manually, since the transaction is deleted from the system after the Void is processed.

There may be an additional option on the Void dialog to delete the transaction without processing the Void. This is restricted depending on your operator access level (see Maintenance / Park Setup / Access Levels), and should **only** be used in situations where you must delete the transaction from Campground Master but cannot get the Void processed automatically. If the Void cannot be processed for legitimate reasons (e.g. the

batch has already been settled), then you should cancel the Void process and enter a Refund transaction instead.

"Full Reversals" -- If you're using PC Charge for the processing software, you may have the option (depending on your merchant processors) support "Reversal" transactions. These are similar to a Void for an unsettled payment, but a Reversal immediately releases the hold on the customer's funds without waiting for a settlement. Reversals also work with pre-paid cards, where Void transactions may not. If this option is available (as selected in the PC Charge setup), a new button "Process card (Full Reversal)" will appear on the dialog. Use that button instead of the "Process card (Void)" button to do a reversal transaction.

Transferring Deposits and Payments

Payments and Deposits may be transferred in part or in full to any other reservation or customer. In most respects this is identical to entering a negative payment in one place and a matching positive payment in another place. For various reasons, however, it's better to use the Transfer functions.

For one thing, negative payments are not possible by non-managers. Also, the transfer function makes it relatively easy to move the money without mistakes (they will match automatically), and it provides an accounting "trail" of the transaction. The Reference field of the transactions will contain information on where the money is transferred from and to.

When doing a transfer, you first need to select the appropriate type from the Transactions dialog. Keep in mind that you can only transfer money that's "available" to transfer. For instance, a Deposit Transfer can only be done up to the amount of the deposit balance (unapplied deposits). If there were no deposits, or if all of the deposit has been Applied to charges already, then a deposit transfer cannot be done. Applied deposits do count as payments, however, so a Payment transfer could be done to move deposit money that has already been applied.

The other factor in choosing the transfer type is the status of the destination. If it's a pending reservation, you may want to only transfer a deposit to it, not a payment. (This depends on your accounting practices -- in some cases, it's not proper to have payments on future reservations.)

The program will decide how much is available to transfer -- Payments can be transferred up to the total amount of payments (and applied deposits) made, even if there are already charges. It will suggest an amount that deducts the charges (assuming you want a zero balance after the transfer), but you can enter the full amount of payments if desired. Deposits can be transferred up to the amount of unapplied deposits, as mentioned above.

Transfers must be entered as a positive amount, and cannot be made if there is not a positive amount available to transfer. (If you mean to transfer the other way, change the "From" option to "To".)

Note: It's also possible to Move transactions completely from one reservation or customer to another. However this should only be done when a known mistake was made, e.g. if a payment was entered the wrong place. Moving transactions that were done on previous days will affect historical reporting, which is different than doing a Transfer of a payment that was initially made on a previous day.

Entering the Transfer Information

The dialog that appears for transfers will show the current reservation or customer information, and the amount available for transfer. To complete the transfer, you need to do 3 things:

1. Select whether the money is going To or From the current reservation or customer (From is the default).
2. Select a reservation or customer for the other side of the transfer, using one of the Find functions.
3. Enter the amount to be transferred, and optionally change the description.

Finally, click Save to perform the transfer.

The Transactions dialog will show one side of the transfer. If you click the Details box, you can see a reference to the other side in the Check # / Ref column. This will show a record number and either a confirmation number or a customer name, depending on whether it was transferred to a reservation or a customer.

Note that if you Cancel the Transaction dialog, both sides of the transfer will be canceled. However if you Delete a transfer transaction, it's possible to delete only one side of the transfer. If it can locate the other side, it will ask if you want to delete the other side also -- you should always answer Yes so that an imbalance is not created.

Grid-Entry Method

As mentioned before, this is the "old" way of entering transactions. This only applies if the prompt-for-details option is disabled in *Program Options*. The differences are described in the online help if you're interested (look under the topic Working with Transactions / The Transactions Dialog / Entering Individual Transactions / Grid-Entry Method).

Printing Receipts

You can print receipts from the transaction dialog at any time, whether you have entered new transactions or not. This can be used to print additional receipts or summary statements for the customer.

You should first select the Receipt Type, if the default is not appropriate. The default will be the type selected in File / Printing Options, and the Ticket form is the initial default. Just select the desired type in the drop-down box before clicking one of the Print buttons to change the style that prints (this will not change the default for next time). For details on the different formats, see the *Receipt Types* section.

Once the receipt type is selected, you can print the receipt. There are two choices for printing:

Print Reservation Receipt (All) will print a receipt with all of the transactions shown, old and new.

Print Only Some Transactions will print the same kind of receipt but with only certain transactions. There are 5 different choices for this.

"New" transactions (last batch) -- If you have added new transactions in this dialog session (they will be in yellow), then only those will be printed. If you have not entered any transactions since opening the Transactions dialog, then this function will print all transactions added in the previous session. Thus you can use this to re-print the last "new" receipt.

Unbalanced (since 0 balance) -- This will generally print any transactions since the last full payment was made. Technically it will find the last "zero-balance" point in the transactions and print any after that point. Since the order of the transactions affects this, there may be cases where it doesn't correctly find what you would consider the last paid-in-full point (for instance if a new charge is added before they make a payment for previous charges, without paying for the new charge to zero the balance). Also note that if there is currently a zero balance (it's already paid in full), then rather than printing no transactions at all, it will print all transactions since the zero-balance point prior to the last transaction (everything since "last" paid in full).

Unpaid (since 0/credit balance) -- This is similar to the zero-balance option, except that it will also consider a credit balance to be "paid", not just zero-balances. For instance if they paid an extra \$20 on their last bill, it won't print the last bill or the payment, only transactions since that time.

Transactions since date -- This allows you to print transactions added since a given date (including those added on the given date). This is most useful to work around problems of payment order mentioned above, or if you need to print an invoice for multiple meter readings or other charges added in different sessions.

Transactions between dates -- This allows you to print transactions in a given date range (including those added on the since & thru dates). This is particularly useful if you're using the post-dating option for future reservations and want to print a receipt that doesn't include those future transactions.

Show "Previous Balance" -- Check this box when printing only some transactions if you want to include a line showing any previous balance (prior to those transactions being printed) and a total "Balance Due" for the reservation. Uncheck this box if you only want a "Statement Total" for the transactions being printed, without showing the total balance due for the reservation or customer.

Post-dated Transactions

If you are using post-dated Charge transactions (as enabled through Program Options / Transactions), those **will** be included on most receipts even though they have a future date. So for instance it will be showing the future balance as of when they check in. The only way to print a receipt excluding post-dated transactions is to use **Print Only Some Transactions** with the "Transactions between dates" option mentioned above.

Information on Receipts and Invoices

Receipts are much different than other reports printed in Campground Master. They are "forms" rather than a grid, so they don't use most of the Print options (Black & White, Fit to Page, etc.). The receipt contains much of the reservation information (confirmation number, number of nights, customer info, vehicle information, site info, etc.), plus a standard disclaimer text, park information (from the Park record), and in some cases an "Additional Notes" section. (If the reservation is not yet assigned to a site, then the first Park record information will be used by default.) If the Check-in and/or Check-out time fields are enabled for Park records, then the receipts will also show these for the customers information. It will also show the check-out date, so they are clear about what date they actually need to leave. If you don't want to show these on the receipt, then you need to disable these fields under Maintenance / Data Field Definitions / Park Fields.

Most of the receipt formats will first list all Charge and Discount transactions, and a sub-total for them. Next it will list taxes if there are any, and Total Charges. Then it will list any payments, deposits, discounts and refunds, and a balance due, credit balance or statement total. It will also show the Paid Through date for the reservation if there is one, as a reminder to the customer when the next payment might be due. If you're printing only New transactions rather than all of them, then the receipt will also show any previous balance (from prior transactions) and the total balance due or credit balance.

There should be plenty of room for all transactions in most situations. Because these receipts are often folded in half and put up in slots for each site in the campground office, the software will attempt to fit the transactions in the top half of the page, shrinking the text if needed. However it can only shrink it to a certain extent (to remain readable), so at some point it will continue down the page if a lot transactions are present.

If there are so many transactions that it won't fit on the page, then it will continue on another page. All of the reference information will be repeated on each page, with only the list of transactions being a continuation. Note that the number of transactions printed on each page is manually specified for each format, rather than actual calculation of space available. If it cuts off transactions too soon instead of continuing, you can adjust the number of transactions per page in Forms Setup.

If you don't want a multiple-page receipt, you could split the reservation at some point and thus start a new set of transactions.

If the receipt is for multiple reservations linked together, the receipt can also show a list of other sites (reservations) that are combined with this receipt. (See Maintenance / Printing Options / Receipts to enable

this feature.) The list will include all synchronized and sub-member reservations under the "master" reservation. If the date(s) or check in/out times for any of the linked reservations are different than the master reservation (i.e. different than the information at the top), then those differences will also be shown.

Receipt Types

There are several basic receipt types described here. By default, all of these (and some variations of each) are set up by default in the Forms definitions. You can disable the ones you don't need, create modified versions, or even create complete custom forms if you like.

Ticket form -- This type was designed to look like a common printed form, familiar to many campgrounds doing hand-written tickets. This is also the only type that will contain the Additional Notes section, which comes from the Park record. There is also a no-color form which will print faster, and also forms with the Site and Dates on the left-hand side (which may work better when folded for showing in windows, etc.). To customize the Notice section of the receipts, see [Maintenance / Printed notices & text](#).

Full-page invoice -- This is designed for a full-size page (Letter, A4, etc.), and prints a professional-looking invoice with the word "Invoice" at the top. The customer's address position can be adjusted for use with window envelopes (see [File / Printing Options](#)). There is also a no-lines version that will print faster, which doesn't put lines around the transaction table. To customize the Notice section of the receipts, see [Maintenance / Printed notices & text](#).

Full-page receipt and full-page statement -- These are identical to the full-page invoice, except that the header will show "Receipt" or "Statement" instead of "Invoice". In addition, the Notice message can be set up differently for these formats.

Register-style statement -- This is similar to the full-page statement above, but the transactions table is in a credits/debits format, similar to a bank statement or check register. This is useful for long-term residents where they might not pay the exact bill each time. They can see at a glance what their balance was on any given date.

Quick-receipt -- this is a basic fast-printing receipt, with no lines or color. It is also small and will print on half-pages or small paper sizes like A5 (landscape mode). This format does not include the "Notice" and customer signature sections like the Ticket and Invoice forms.

Confirmation letter -- This is in the form of a letter, designed for use as a reservation confirmation. It has the transactions table like the other receipts (with no lines, for a more letter-like appearance), and also includes customizable text sections for the confirmation notice (see [Maintenance / Printed notices & text / Confirmation letter text](#)). The Notice will not include a customer signature line as it does on invoices and receipts. The customer's address position can also be adjusted for use with window envelopes (see [File / Printing Options](#)).

3" Receipt Printer -- This is generally only used for retail-type receipt printers, typically using a 3" or smaller paper roll. This will print a special format suitable for a narrow printer, so it could also be used with any small-format paper slips. The transactions are printed on two lines instead of one so there is room for the description. If your printer does graphics and non-fixed (TrueType) fonts well enough, then you may be able to use the first (non-fixed) option. Otherwise, you may need to use the "fixed-pitch font" option for more readable printing. Make sure you have the printer's fixed-pitch font and number of columns set up in [File / Printing Options](#) if you use the fixed-pitch font option.

Note that there is no special provision for a paper cutter on receipt printers. If the driver for your printer has an "automatic" cutting function which knows when the printing is finished, that should work, but otherwise a paper cutter is not directly supported. You may also be able to insert special control characters in the bottom text that prints at the end of the receipts to tell the printer where to cut the paper (this works best with the direct-to-port format below).

3" Receipt Printer, direct to port -- This is the preferred method of printing on simple 3" receipt printers, because it doesn't require a Windows driver and is very fast. It sends raw text to the printer, so it will print in

the printer's native font. Note that this option will not be shown unless the Direct to Port settings have been set up through File / Printer Setup, and it only works if the printer is directly connected to the computer through a parallel or serial port. If the printer uses a USB connection or is accessed through the network, this option cannot be used.

Credit Card Slip -- These formats are designed for the customer to sign when paying by credit card, and work on 3" receipt printers so they're similar to the 3" receipt printer formats above. Normally you would not select this unless Campground Master is doing the actual credit card processing, and then it's normally configured to print the slip automatically. However you can select this to print another copy if necessary. Note that both the these formats (normal and fixed-pitch font) use the corresponding 3" Receipt printer settings.

Window Tag -- This is a special form used to print a form suitable for placing in vehicle windows. It includes the park name & address (small), customer name, confirmation number and vehicle license numbers, plus the Site name, first night, and last night in large font. This can be printed on plain paper (typically folded in half after printing, or on special long tags fed in the printer like envelopes, or even a 3" receipt printer in landscape mode (if it supports TrueType fonts). If the paper is large enough to be folded in half (e.g. larger than about 6" tall), then you can fill the bottom half with rules and other text (see Maintenance / Printed notices & text / Window Tag bottom text).

Note that while a window tag is not technically a receipt, it can generally only be printed from the same functions receipts are printed -- the Transactions dialog, [Reports / Reservation Receipts](#), and the right-click printing functions such as [Print for this Reservation / Receipt](#).

E-mailing Receipts

In addition to Printing receipts, you can also E-mail confirmations, receipts, etc.

Before you can send E-mail from Campground Master (and in fact before the option will even appear to do so), you must configure the SMTP setup so it knows how to use your E-mail server. See that section for details (under Maintenance / E-mail Setup / SMTP Setup for sending E-mail). You will also want to review some of the settings under E-mail Setup to configure the [Confirmation E-mail text & options](#), [Invoice E-mail text](#), etc.

Once that is configured, then you will have a button on the Transactions dialog to "[Send E-mail Form](#)". (Note: If you have only one E-mail Form enabled, the button will read "[E-mail Confirmation](#)" instead, with the assumption that the E-mail is a confirmation letter).

Assuming more than one Form is available, clicking this button will show a dialog to Select the Form to E-mail, as well as some other options such as Preview before sending.

Note that the E-mailed confirmations and invoices, etc, will look a lot different than the printed versions. They are designed to work as simple text E-mail messages. While it's possible to design fancier E-mails using HTML, that's an Advanced Customization feature. Look for examples in Newsletters to get some quick tips, for instance to add a logo to your E-mail.

Selecting Rates

For site rentals and many other common transactions, you will probably have a number of Rates defined to speed the entry process, and to avoid mistakes that can occur if you had to enter the value each time.

When you click the Select Rate(s) button a new dialog will appear, with applicable Rental Rates and Add-Ons shown by default (for Reservations). You can change the Rate Type to see other types or all types using the drop-down list. Some applicable reservation information appears at the bottom of the dialog for reference when selecting rates or entering quantities (the number of nights, discount, and any synchronized sites are shown).

Note: If you want to change which Rate Types are shown by default, check the box "Make this the default" after selecting the desired Rate Type. (Make sure you close the dialog using "OK" rather than "Cancel" or else it won't save the change.) This setting will be specific to each workstation, and also separate for Reservation Transactions, Customer Transactions and Unbound Transactions.

Note that the rates shown in the list are based on a lot of different factors in the Rates Setup. If you're not seeing a rate you expect to see, you need to review the rate definition and the reservation. A rate might not appear if the discount type selected is different than defined for the rate, or if the site's type or class is different, or the length of stay is too long or short, or if the reservation date range is outside the rate's season or in the special exclusion dates.

Note for Linked reservations: The Select Rates function can only show rates for either a single reservation or a synchronized set of reservations at once. Therefore if the reservation is linked to sub-members, you will need to do Select Rates for those separately. (A warning message will appear if this is necessary.) To Select Rates for a particular reservation, select (highlight) that reservation from the list in the Transactions dialog before clicking the Select Rates button.

Rate Quick-Finder (optional)

If you have the Rate Code field enabled, you can select a rate by typing the rate code in the Rate code quick-finder field (the cursor will start there so you can just start typing). When the correct rate is selected, just press **Tab** to move to the Sites or other Qty field if needed, or go ahead and Add the rate (**Alt-A**). Note that this only works if the rate shows up in the list, e.g. if it's applicable to the current reservation, etc.

Discount Used

This is a drop-down list of discounts, identical to the discounts on the Transactions dialog. Any previous discount used will be automatically selected here. There are two reasons this selection is duplicated here:

1. When checking in customers, this may be the first dialog that appears (it will "skip" the Transactions dialog if the Options are set up to do so), so you need to be able to select the rate here.
2. It can also be handy to check different discount rates at this point to find the best rate. Just select different discounts and the applicable rates will be shown immediately.

Auto-calculate All Rates

If auto-rates functionality is enabled, this button will instantly select the appropriate rates and quantities for the reservation. Actually this can be done directly from the Transaction dialog instead of coming into Select Rates, but if you prefer to see the actual rates selected first, then you can do it from here. (This is also useful when using Check Rates, if the option to do it automatically for Check Rates is disabled.)

Adding Rates

Just click on the desired rate in the list (or use the quick-finder), change the qty field(s) if necessary, and click Add. If you know that the quantities don't need changed, you can just double-click the rate and it will be added with the default quantities immediately (see below for more about the quantities). Therefore in most cases, such as simple daily rates, all you will need to do is double-click the appropriate rate, then click Done to finish the rates selection.

Override auto-selection

By default, the rates list will show rates that are specific to the current reservation (by site type, discounts, etc.). However there may be times when you want to select a rate that's not normally used for this reservation. Check the Override box to disable the filtering and show every rate defined for the selected rate type. Note that this is separate from the auto-rates calculation, so it won't affect auto-calculations.

Note: If the override option is used, it probably means the rate definitions need some adjustments. However it is provided as a quick fix or to manually select a non-standard rate.

Quantity Fields

Whenever a rate is highlighted in the rates list, one or more quantity boxes may appear to the right. These depend on the options selected in the rate definition, and can include a period quantity (Day, Week, Month, or Year), a Site quantity, or a simple Qty field (or any combination of these). By default, these will be filled with a number appropriate to the reservation for which you're adding transactions.

For example, the Days quantity will automatically be filled with the number of reservation nights. This assumes that the rate applies to all of the dates of the reservation -- otherwise it will only include the number of days that match the rate definition. Weeks, Months, and Years will be filled with a "truncated" number for the period -- thus a 20-day reservation would show 2 weeks, since it's assumed that you will also add the extra 6 days as a daily rate. (However if the reservation was for less than 7 days and you use a weekly rate, it would still assume that they are paying for 1 week minimum, not 0.)

Note -- the default number of days (or other period) automatically takes into account the paid-through date, and also any previously selected rates (but only during the same Select Rate(s) dialog session -- any charges added previously won't be taken into account unless the Paid Through date has been updated accordingly).

For instance, for a 16-day reservation that has already been paid through the first week, it will start by showing 9 days unpaid (this shows at the bottom of the Rate Selection dialog). If you then add a weekly rate, it will know that 1 full week has not been paid/charged yet, so the quantity will be 1. After adding that week, when you select a daily rate to complete the charges, it will know that only 2 days are needed at the daily rate. This also works for reversing charges -- if a reservation is checked out and its paid-through date is 2 days later than the last night, selecting the daily rate will correctly assume -2 days.

If the reservation is synchronized with other reservations, the Site quantity will automatically reflect the number of synchronized sites that satisfy that rate's criteria. Keep in mind that a group of reservation may cover more than one site type, so you may have to Add more than one rate to cover all of the synchronized sites.

Once the quantities are verified to be correct, just click Add to add the rate with the quantities shown to the Rates Selected list at the bottom. (Note: If the qty is 0, then Add will not do anything.) The tax amount is automatically calculated and shown along with a total. If you need to correct a rate, highlight the entry in the Rates selected list and click Delete Selected Item(s). Then add the rate again if necessary.

Multiple Rates

You can repeat the rates adding process to select multiple rates of any type before leaving this dialog, and each one will appear in the Rates Selected list at the bottom with an updated quantity. When all needed rates are selected, click Done to accept all of the selected rates and add the rate charges to the New Transactions dialog. In fact, it's recommended that you add all of the rates at once, so that the number of days, weeks, etc. is calculated correctly (it will keep track of the number of days being added for the currently added rates, but if you click Done and then come back into Select rates, it won't remember what rates have already been added).

Metered Rates

For metered electric, gas and water rates, there is a special dialog that appears when you Add the rate. (This requires that the "Ask for meter reading" flag be set on the Rate Definition.) This dialog shows the site name, the previous reading and date, an actual reading date selection, and a button to view the last reservation that read the meter (in case there is a dispute). All you have to do is enter the new reading, and it will add the appropriate rate charge and also update the reading information in the Site record. If the reading was actually taken on a previous day, you should also select the correct date for Actual date of reading. Note that any other quantity entries on the Select Rates dialog will be ignored (and the rate definition should be fixed to not ask for a quantity if you see a Qty box).

Note that meter wrap-around is handled automatically, as long as the wrap-around figure is set in Maintenance / Park Setup / Parks. For instance if the meter only has 4 digits and the last reading was 9900 but it now shows 0200, just enter 200 and it will know that 300 units were used. Note that the wrap-around must be less than 25% of the entire range (e.g. 2500 if it's a 4-digit meter). An error will be shown if the figure you enter cannot be understood as either greater than the previous reading or a reasonable wrap-around.

Other Options

There is an option to Invert amounts of the rates -- this will turn all quantities into negatives, so this can be used to cancel out a charge or for refunds -- however, note that the transaction categories will **not** be changed to "refund" or "credit", so this could affect reporting. If you're not concerned with reporting refunds separately from charges, then this is the easy way to do it. Of course if you're just canceling a reservation, it's probably best to just delete any associated charge transactions directly in the Transaction dialog, rather than adding negative charges.

If you're entering rates for multiple linked reservations, there will be an option to Use separate entries for each site. This is normally selected by default (but can be changed to unselected by default in File / Printing Options), and will result in a separate line-item charge for every site for which you're adding a rate. The separate charges will also include the site name, so the receipt will show a record of all sites that have been charged.

However, there may be times when you prefer not to show separate lines for each site. For instance, if you have many (over 20 or so) sites linked, then the receipt may not hold all of them. Also note that there will be a separate line item for each transaction defined in the rate -- so for instance if the rate includes a Charge, a Discount, and a Credit (e.g. a coupon), then all 3 of these would be duplicated for each linked site.

Finishing Up

When you're done selecting rates, transactions will be generated according to the transaction templates in the rate definitions, plus transactions for any auto-added taxes. These will appear as new transactions in the Transactions dialog, just as if you entered them manually. You can adjust them if necessary or delete any that you added by mistake. (Take care in deleting individual transactions back in the Transactions Dialog, since the tax won't be re-calculated.)

Back-dating Transactions

If you're entering historical transactions, or for instance just need to enter something that was missed on a previous day, you can easily change the date of a transaction (provided you're logged in with a high enough access level).

First enter the transaction as you normally would, and then before clicking "Done" to finish the transaction, make sure the Show Date checkbox above the upper right corner of the transaction grid is checked (if you're in the POS dialog, check the Details checkbox as there is no separate Show Date checkbox). Once checked, you will see the Date column (2nd column, next to the Type). Just click on the date to be changed and you can enter a new date (clicking twice gets into edit mode to edit just part of it). After entering the new date, press the Tab key to exit the field.

Likewise you can change the date of a previous transaction by re-opening the Transaction entry dialog and using the same procedure.

Note that this only affects the "posting" date of the transaction -- there are separate fields for Date Made and Time Made to record when the transaction was initially entered in the system, which cannot be altered.

Security Deposits

Key deposits and other "security" deposits need to be handled differently than the "advance" deposits. When you use the "Deposit" transaction, that's assumed to be an advance deposit that will be applied to the rent or other charges. However for security deposits you don't want this -- and you probably want the balance to show \$0 even though they've paid the deposit, and be able to refund that deposit when they leave.

Here's what we recommend for this:

Set up a Transaction Category of "Security Deposit" if it's not already there (anything besides "Deposit" will work, which is reserved for advance-deposit transactions).

At the beginning of their stay (or whenever you need to enter this type of deposit):

- Enter a Charge transaction for the security deposit, using that Security Deposit category.
- Enter the payment for the deposit as a normal Payment transaction (or as just part of their check-in payment).

This will show the deposit as income now, but you'll have a record of the security deposit because of the Charge transaction, and the separate category allows you to separate it if needed. It will also zero-out the customer's "balance due" so you don't get misleading balance reports.

Now when they leave:

- Select the original Security Deposit transaction and click Reverse Charges to negate it, which will add a negative Charge. This will give them a credit balance.
- Enter a Refund transaction if there's still a credit left after any final charges.

Of course you can also set up Rate definitions to simplify this, or even have it add the security deposit automatically as an add-on (assuming you use auto-rates). When they leave, go to Select Rates, add the security deposit, and check the box at the bottom to "Invert Amounts" so it's added as a negative charge.

Bounced Checks

If you want to show that the check was returned and a customer still owes the money, then just enter a Payment with a negative amount (manager or higher access level is usually required for negative payments).

If you want to also cancel the charges (as a write-off) so they don't have a balance due, then you need to first put in the negated charges. For instance go to Select Rates, add the rates to be negated, and check the

"Invert amounts" box to make them negative before clicking Done. Then, enter a negative Payment (or a Refund) so the balance is \$0.

You can also add a Memo transaction to show the reason for the entries, or just change the Description of the Payment or Refund to show something like "NSF" (this is bank language for Insufficient Funds).

Reservation Transactions

Access to the Transactions dialog for a reservation is available in several places. The simplest way to get to it is to click on Transactions in the right-click menu of the tab views (for the appropriate reservation, of course). If you're already in a Reservation Details dialog, then you can simply click the New/Edit Transactions button. You will also get the Transactions dialog automatically when performing certain functions like checking in, checking out, and canceling a reservation.

You can also get to it through the main menu (Transactions / Enter Reservation Transactions). If a reservation is already selected (highlighted) on the current tab view, then transactions for that reservation will be shown. Otherwise, you will then need to use the Find Reservation dialog to locate the reservation for which to make the transaction.

Note for linked reservations -- Since transactions can only be added to one reservation, typically you would use only one of the reservations for all of the transactions when one person is responsible for them all. However, this can result in some inconsistencies in transaction reports that are grouped by Site Type or Site (all of the charges and payments will appear on one site, even if the linked reservation is on a different type, such as a Cabin and a Boat Dock). The only way to avoid the inconsistencies would be to enter separate transactions on each reservation, but that would require you to print multiple receipts for the customer. There isn't a good solution to this, just be aware of the advantages and disadvantages of the two ways of doing this.

Also note that when entering reservations for synchronized reservations, the software may warn you if you're not adding them to the "master" reservation. It's recommended to keep them all with the master when possible. (This will happen automatically by default, but there is an option to disable the automatic-master transactions, resulting in a warning if you don't select the master.) When adding rates, you can add the charges for all of the synchronized reservations at once, so it's easy to keep them with the master.

Using the Transactions Dialog for Reservations

At the top of the Transactions dialog is reservation information most likely to be needed when determining the rates. This is a grid showing the main reservation and any reservations linked to it for which billing is combined (synchronized and sub-members). In addition to some typical reservation fields, it shows the number of nights in the reservation, the Charged-Through date and the Paid-Through date.

The Paid-Through date is of special importance -- before finishing transactions, you should verify that this is correct. For convenience, there is an All Paid Thru Last Date button which will automatically put each reservation's Last Night in the Paid Through date, to indicate that it's paid in full. Also note that if you do enter a payment and forget to set (or change) the paid-through date, you will get a warning prompt when you click Done. The prompt will give you the option to automatically make it paid through the last date (most likely), or to not adjust the paid-through date, or to go back and change it yourself.

You can use Reservation Details button to get to the Reservation Details dialog and make any changes necessary before adding charges (although this button will be disabled if you got to the Transaction dialog from the Reservation Details dialog).

For further details, refer to the *Transactions Dialog* section.

Special Considerations for Linked Reservations

A single collection of linked reservations can contain some that are billed separately and some combined, and even the combined ones can have different dates. Therefore the Transactions dialog will show a list of reservations that will be billed together, with their dates (first, last, charged-thru and paid-thru).

Important points about the Transactions dialog (e.g. New / Edit Transactions) for linked reservations:

- Since the reservations listed in Transactions might not be synchronized, the dates cannot be changed directly. Reservation Details must be used to make date changes (except for Paid-Thru, which you can click on to change).
- To view Reservation Details for any of the reservations listed in Transactions (if more than one), select that reservation before clicking the Reservation Details button.
- Select Rates can only operate on one set of synchronized reservations at a time (it can't handle reservations with different dates). Therefore to select rates when more than one group of synchronized reservations are involved, you may need to do it in separate groups. For each one, select one of the reservations in the list before clicking Select Rates.
- If Auto-Rates is enabled, it will calculate for ALL reservations appropriately -- there is no need to do it in multiple groups as with Select Rates.
- You can print Window Tags or other receipt formats for individual sites/reservations -- just select the desired site (reservation) in the list before printing a receipt.
- Most receipt formats will print using the "master" reservation's site by default (if no specific site is selected in the list), but will also include as many of the linked sites as will fit in the designated space on the receipt. (This is an option that can be disabled in File / Printing Options / Receipts)

Auto-rates notes

The auto-rates calculations will always include charges for all appropriate linked reservations (synchronized and sub-members, but not non-synchronized). These will be added to the "top-level", or "transaction master" reservation. Also note that if auto-recalc is enabled (to automatically recalculate whenever a change is made), ALL linked reservations are recalculated whenever a linkage change is made. For instance if a reservation is changed from Synchronized to Non-synchronized, that may result in charges being moved around to the new top-level reservation (for each non-synchronized set).

Another important note is that if you have it set up to auto-add charges when they check in, this will actually happen when the first of any linked reservation (with combined billing) is checked in, and it will add charges for ALL appropriate linked reservations. So for instance if a sub-member is checked in first, charges for that reservation, it's owner, and any other synchronized or sub-member reservations in the tree will be added. Furthermore, they're always auto-added to the top-level/master reservation (and the Transaction dialog would automatically open for that reservation).

In our example above, lets say that Stall 1 was checked in before any of the others (their horse arrives early). Since it's in a synced/sub billing group, the top-level reservation (RV 1) will be selected for billing, and charges for all combined-billing reservations will be added (RV 1, RV 2, RV 3, and Stall 1). While this is an unusual situation, it's probably appropriate -- presumably any synced or sub reservations are all for the same customer (it will only combine billing for the same customer anyway), you would expect them to pay for everything the first time they check in, even if they're not ready to use all of their sites yet. Remember, you can always change the linkage to create separate billings if needed.

Customer Transactions

You may occasionally want to make transactions that are applied to a customer but not to a reservation, such as gift shop purchases, or advance deposits for reservations not yet made. To do this, you will need to use the Transaction button on the toolbar (the cash register), or [Transactions / Enter Customer Transactions](#) from the main menu. If a customer is already selected (highlighted) on the current tab view, then transactions for that customer will be shown. Otherwise, this will open a [Find Customer](#) dialog to locate the customer for which to make the transaction. (This works the same as Find Customer in New Reservation dialogs -- sort by the appropriate column, find the customer, click on it and click Use.) Once you find the customer to use, just click the [Use](#) button to enter transactions.

At this point, the Transactions Dialog will appear, just like for reservations. It functions in every way like the reservations dialog, with the exception that the customer information will be shown instead of the reservation at the top (there is nothing to edit here, but you can go to [Customer Details](#)). You will see any previous transactions for this customer, including any transactions for reservations this customer has made. Therefore you could use this to print a transaction receipt/statement for the customer that covers all of his past reservations.

Another difference is the receipt appearance, even though it's the same format as the reservation receipt. The Site and first/last nights area will be blank, the disclaimer/signature area will not be shown, and the park information will use the first Park defined in the database (since there is no reservation and thus no associated site to get the park information from).

One final thing to remember is that transactions here will **not** be reflected in any of the customer's reservations. This may be important for "balancing" reservations -- don't enter a payment for reservation charges here because the reservation will still show a balance due. You should get to Transactions through the appropriate reservation to enter any reservation charges or transactions.

For further details, see the *Transactions Dialog* section.

Unbound Transactions

P.O.S. note -- If you have purchased the P.O.S. option, you will probably never use Unbound transactions -- you will use the Point of Sale for any merchandise sales. Refer to that section for details. If you don't have the P.O.S. option, then Unbound Transactions are used as described below.

You may occasionally want to make transactions that are not applied to a customer or a reservation, such as gift shop purchases by walk-in customers (no need to clutter the customer database with non-campers or strangers). To do this, you can use the Transaction button on the toolbar (the cash register), or [Transactions / Enter Unbound Transactions](#) from the main menu (depending on options settings for the action of the cash register icon).

At this point, the familiar Transactions dialog will appear, just like for reservations and customers. The main difference is that there is no customer or reservation information at the top. Another difference is the receipt appearance, even though it's the same general format as the reservation or customer receipt. It will only show the park information, (the first Park defined in the database will be used, if you have multiple Parks set up).

If you do Select Rates for unbound transactions, the Merchandise rate type will be selected by default, since you're most likely entering counter sales.

The Deposit button will be disabled for unbound transactions -- deposits cannot be properly tracked for unbound transactions (and don't really make sense), so they are not allowed.

Since unbound transactions are not linked to a customer or reservation, they will only appear in the Transactions report (tab view) once you've entered them -- there is no other "transaction history" function for unbound transactions. If necessary, you can edit an unbound transaction by locating it on the Transaction report and using the Transactions option on the right-click menu. All transactions entered at the same time (one Transaction dialog session) will still be grouped together, so for instance you can make changes to a counter sale and print out a complete new receipt. (Note: this only applies to unbound transactions entered with Campground Master version 1.2 or later -- previous versions did not support the grouping.)

For further details, see the *Transactions Dialog* section.

Transaction History Dialog

This dialog is used for the Transaction History function from Reservation Details and Customer Details. It shows a list of all transactions for that reservation or customer, including the details of each transaction.

Most of this information can also be accessed through the New / Edit Transactions functions on those dialogs, but there are a few special purpose functions available here.

Prior transactions -- If you have previously used the Purge functionality to clear out old reservations, then a customer's Transaction History will show the total amount of payments the customer had in the purged transactions. This is simply for informational purposes so you can see if the customer has been a regular visitor. (Since only "balanced" transactions can be purged, you can assume that there was no outstanding balance for the purged transactions, so the amount "charged" was equal to the amount paid).

Print and Export -- You can print this detailed history list if needed, or export it to a text file.

Move Up and Move Down -- If you have sufficient operator access (Administrator by default), you can move selected transactions in the list. This order affects the order that transactions are printed receipts on receipts, so it can be useful when entering prior transactions that were missed. It can also be useful for getting payments categorized properly in the Receipts by Category report (because charges must appear before the payment for those charges in order to categorize the payments properly).

Note that if you're in a reservation's transaction history, moving transactions will also move them in the customer's history. However if you're in the customer's history (e.g. from Customer Details), moving transactions only affects the order in the customer's history, not the corresponding reservation. Therefore always access Transaction History from the Reservation Details if you need to move reservation transactions.

Also note that moving transactions here does not generally affect their order in the Transaction tab view (reports), because that sorts by date, time, and the record ID. (Moving transactions around doesn't affect the record ID, only the logical position in a list.)

Warning -- Be very careful about moving Deposit and Deposit Applied transactions -- the order of these is very important for proper reporting of deposit account balances and exporting deposit amounts to QuickBooks.

Move to a Different Reservation or Customer -- This allows you to move the selected transactions to a completely different reservation or customer. It can also be used to move a Customer transaction to a Reservation or vice-versa, for instance if the transactions were entered through the wrong dialog.

This function should be used only when necessary, and with extreme caution! Once moved, there is no "Undo" function, and if you move them to the wrong place it can be difficult to locate the transactions again. Also note that moving transactions will most likely affect the Receipts by Category report, if not moved as a zero-balanced charges/payments group. Therefore this should only be done when a known mistake was made, e.g. if a payment was entered the wrong place, and you need to correct it without deleting the original and re-entering it.

Selecting the Move destination...

The dialog that appears for selecting the "Move" destination will show the current reservation or customer information.

You need to first select a reservation or customer to move them to, using one of the Find functions. Remember the difference between Reservation and Customer transactions -- if you use Find Customer to select a customer, then the transactions will not show on any reservation for that customer -- they will only appear in the transactions for that customer. If the transactions are supposed to be for a particular Reservation, then you must use Find Reservation and locate the specific reservation (for the appropriate site and dates).

Finally, click OK, Move Transactions! to perform the move.

Misc. Income and Expense Transactions

These transactions are different than others in that they are not done in charge/payment pairs, don't have separate tax and discount entries, and so forth. They are single transaction entries, like entries in a ledger. As such, you won't use the same grid-style transaction dialog as you do for reservation and customer transactions. These should only be used if you are using Campground Master as your only accounting software, which would probably only be suitable for the smallest of campgrounds. Manager access is required to enter Expense and Income transactions.

To enter these transactions, use the menu functions to Enter an Expense Transaction or Enter a Misc. Income Transaction from the Transactions main menu. If you use the Transaction button, then click on the appropriate button at the bottom of the dialog to enter an expense or misc. income transaction. Note that the operator will need to have a Manager access level or higher to enter these transactions -- the menu/button options to enter them will be disabled otherwise.

At this point you will get a small dialog for either expenses or income (they look the same, just with different wording). Here you can enter the transaction date (defaulting to today but you can use it to enter old transactions easily), the payment or receipt method, check # or other reference, category, description, total amount and any notes.

These fields have all been covered in other sections and work the same here, except that you'll notice that no other transactions have a field for Check # / Reference. This is only used for these ledger-type transactions, and you can use any text you like in this field. You'll also notice that there is no Qty/Each, just one Total Amount field. As with others, no dollar sign is needed here, just enter an amount like "123.95" or "100".

After entering the transaction data, just click Save (or Cancel to abort it). When you view the Transactions tab, you will see the new transaction (assuming you're viewing the date entered in the transaction dialog).

Monthly Billing

This function is available under Transactions on the main menu, and is used for adding monthly charges to all reservations with the reservation type set to Monthly.

Overview

The Monthly Billing function uses the auto-rates functionality to add appropriate charges to all of your long-term reservations at once. Through the various configuration options, you can customize it to the way your business bills long-term residents or reservations.

Only reservations of the Monthly type (and optionally Owner type) will be used in monthly billing, so make sure that you set this type for any reservation that you need to bill on a monthly basis. This is done when making the New Reservation, or it can be changed through Reservation Details. For more details on how best to add and manage reservations to be used with the Monthly Billing function, see the section under *Working with Reservations*, "Monthly / Long-term Reservations".

The table on this dialog shows the basic reservation information, plus the current balance due and the new charges that will be applied for this month's billing. If you want to print this as a report or export it, you can use the [Print List](#) or [Export List](#) buttons. Note that the New Charges amount might remain even after charges are applied (depending on the settings), although the Current Balance amount will change to include the new charges.

Rates Setup Requirements

Monthly billing uses the defined Rates and the auto-rates calculation logic, so you don't need to specify the monthly rate for each and every reservation. (This also allows price changes to be automatic for everyone). In order for monthly billing charges to be correct, you must have the Rates set up properly, following all of the same guidelines as Auto-Rates. If there are rates that should *not* be used for monthly billing, for instance your normal daily rates (presuming you have a separate rate for pro-rating partial months), then you need to make sure that those rate definitions don't have "Monthly" included in their Resv Types list. Of course if there are some that shouldn't be included for any auto-calculations at all, like special add-ons that you add manually, then make sure those have the "Exclude from auto-rates" option checked.

Charged-Through and Bill-To

The program generally determines how much to bill by doing auto-rates calculation for the days between the reservation's current "Auto-charged through" date (which is automatically adjusted each time) and the Bill-To date you specify in the Monthly Billing dialog. The Bill-To date is set automatically to the end of the nearest month -- for instance if it's now March 25th, it would set the Bill-To to April 30th, assuming you want to pre-bill them through April. If it's April 3rd, it would still set it to April 30th, assuming you're going to do billing for this month. If the program guesses wrong, you can simply change the date or use one of the End-of buttons to quickly set it appropriately.

In the above example, any reservations that have not been charged for all of April (including any only partially charged through April) will be included in the list to be billed. You can also opt to show any not yet paid through a particular date, regardless of how far in advance they might have been charged. This is normally included so that you can include customers that have been charged for the month but have not yet paid.

Actually, The "Also include any not yet paid thru" option is usually selected for another reason -- after adding charges to the reservations listed, the list will be refreshed. Since the auto-charged-through date is also updated for the reservations, any that are now charged through the indicated Bill-To date will not be listed, which means they would probably all disappear before you get a chance to print them. (You could adjust the date to the next day to get them back, but that might also show some you didn't expect to print). So we recommend always setting this option, and using the same date for both the bill-to and paid-thru settings.

Although auto-rates are used, you can tweak the actual amount of time billed for various special cases using the options settings described below. In the simplest scenario it would add charges from the end of this month to the end of next month, resulting in a single monthly charge. The monthly billing can also "fill in" charges to catch up billing (for instance if they only paid for a partial month upon check-in, or if they are scheduled to leave in less than a month).

Obviously it's important to keep the auto-charged-through date accurate for the reservations. In general this is not a problem if you use the auto-rates functionality. However this date may get cleared or improperly set if someone adds charges manually or deletes previous auto-charges. It's a good idea to review the charged-through dates of all of the reservations before doing the billing to look for problems. This is easily done by

sorting the list by Charged-Thru (click on the column header). If you see any that aren't correct, just double-click on the line to open the Reservation Details and adjust the date.

Errors

If it cannot find any applicable monthly rates for a given reservation, it will show "ERROR" in the New Charges column. If you see this, you need to review your Rates definitions and find out why none of your rates apply to that particular reservation.

Another common error is an incorrect amount due to a rates definition mistake. The only way to detect this is to scan through the New Charges column and see if any rates don't look right. If you see one that's questionable, simply put the mouse cursor over the value in New Charges. A pop-up tip will show what charges will be applied to the reservation, including the description, amounts, etc. This can help you pinpoint rate definition problems.

Options

The options selected here will be remembered each time you use Monthly Billing, and usually don't need to be changed from month to month once you have it working the way you want. Except for the first one, these are all accessed through the Billing and Printing Options button.

Show linked reservations separately -- This will allow you to see not only the master reservations to be billed, but also all linked reservations due to be billed. Note that this does not affect which reservations the charges are applied to or printed, but allows you to see the New Charges broken out by site. Since it doesn't affect the billing or which actual reservations are shown and billed, just *how* they're shown, it has been placed on the main dialog instead of in the Billing and Printing Options.

Exclude reservations not yet checked in -- if you don't want to pre-bill monthlies that haven't yet arrived, check this option.

Exclude reservations leaving before the bill-to date -- While the auto-rates calculations can handle the actual charges to the end of their stay, there may be other reasons that you don't want to bill them at all this time (for instance if their actual departure date is often uncertain, and you prefer to charge them when they leave).

Use paid-thru date as the bill-from date, if the reservation's charged-through date has not been set -- While this is not generally recommended, you may need to set this to cover reservations that might not have a charged-through date due to charges adjustments. (A better method would be to review all of your monthly reservations and manually set their correct charged-through date in Reservation Details).

The next group of 4 options are the most important for determining what to charge each reservation depending on its last charged-through date, the bill-to date, and its Last Night (departure date). Note that if all 4 of these are NOT checked, then 1 month's charges will simply be added to each reservation to be billed, starting from the current charged-through date. The following 4 options are for fine-tuning the billing.

(The following options may actually use a specific number of days instead of a calendar month, depending on your Monthlies Options.)

Charge to at least bill-to -- With this option set, it will add charges all the way from the last charged-through to the bill-to-date, no matter how many months (or partial months) that would be. This is great for "catching up" on missed billings, but may bill for more than you expect if a reservation's charged-through date isn't accurate. Note that the reason it's worded as "at least to..." is because it can still bill beyond the Bill-To date if the next option is set.

Charge only in full months -- This option can be used if you don't want any partial-month billing to occur. For instance if your bill-to is April 30 but the reservation has already been charged through the 15th, it will still add 1 month (and adjust the charged-through to May 15 after billing). This is a good choice if you don't try to keep your billing in sync with the 1st of the month and just charge months from their first night. Note that this can still be overridden by the next option.

Limit charges to the end of the reservation -- This will prevent charging a full month if their Last Night occurs before the bill-to-date -- it will attempt to use weekly or daily rates as appropriate to bill their remaining time. More precisely, it charges from their current charged-through to their last night, charging a partial month if needed. So if the previous option was also checked along with this one, the example given above would still result in a partial-month bill if their last night was May 10, for instance.

Don't add any charges if already charged for part of the month -- With this option selected, then instead of billing for a partial month or charging beyond the bill-to date, it simply wouldn't add any charges at all if it can't add a full month. This effectively overrides the previous 2 options, since it can't add charges past the bill-to and it can't add partial month charges.

Handle synchronized reservations individually -- If this is checked, then charges will be added to each reservation individually (and individual invoices printed) for synchronized reservations. While this is normally not done for short-term reservations (the "master" usually takes the charges for all of the synchronized sites), there is an important reason to do it for monthly billing -- if any of the synchronized sites has meter charges, those cannot be combined into the master so you will need to print separate invoices for those anyway. If synchronized sites are always non-metered (e.g. a storage space) then it would be OK, but otherwise it's recommended that synchronized sites be handled separately for monthly billing.

Include Owner-type reservations in addition to Monthly types -- Check this if your owner reservations also need to pay monthly charges like a maintenance fee.

Printing Options

Include dates charged in descriptions -- When this option is checked, every charge line on the invoice will show the dates it's charging for. This is very useful for keeping track of what's charged, but it does make the description longer.

Invoice format -- This will initially default to the "Reservation Receipt default format" selection chosen in [File / Printing Options](#). You can select a different type here to be used for monthly billing, and it will be saved for future monthly billings (but will not affect other receipts). Thus the default receipt type for monthly billing can be different than the type used for normal receipts. See Receipt Types in the *Working with Transactions* section for details on the different types.

Note that only one copy of each receipt will be printed (each time the printing button is pressed) -- the "Copies" setting in the Printing Options is ignored.

You also have the typical options for what transactions to include, either All transactions or just some, like for printing receipts from the Transactions dialog. The most common option selected for Monthly Billing is "[New transactions \(last batch\)](#)", so it just prints the monthly rent charges. however you may want something else so it also includes electricity charges, for instance.

Editing and Selecting Individual Reservations

If there are some reservations that shouldn't be billed this time, or if you need to print bills for just certain reservations, you can do this by selecting individual reservations in the table. Use Ctrl-Click to select one or more lines. Only those selected will be affected by any of the button functions below the table -- extending, charging, or printing. (If none are selected, then it's assumed you want to use all of them -- there is no need to select them all.)

Extending Reservations Automatically

At some point you may need to extend all of the monthly reservations to keep the site reserved. Depending on how you set the dates initially (see the Monthlies Options under Maintenance / Program Options), you may want to do this every month, or perhaps just extend them for another year at the end of each year. Either way, all you need to do is click the Extend 1 Month button (which may actually be a specific number of days instead of a calendar month, like Extend 30 days, depending on your Monthlies Options). This will either extend all listed reservations (if none are selected), or just the selected ones. You can click it as many times as needed to add additional months -- you will see the Last Night advance for each reservation. Note that this only changes the Last Night for the reservations, not the Blocked date.

If extending a reservation will cause a conflict, an error message will be displayed and that reservation will not be extended (any others that don't conflict will still be extended). You will need to find the conflict and correct it before you can extend that reservation.

If a reservation ends on the last day of the month, extending it one month will extend it to the last day of the next month, even if it's a shorter or longer month. However if it ends on any other day of the month, it will extend it to the same day on the next month if possible. (If the next month is too short, it will extend to the last day of that month.

Adding Charges

Once you're ready to add the charges to the reservations (and have confirmed that the New Charges look correct for all of the reservations), just click the Add Charges button. The charges will automatically be added to each reservation and the Current Balance will be updated in the table.

However, if it's necessary for your accounts receivable that you can't add charges yet but you do want to print invoices for next month, then you can use the Pre-print Invoices function (see below). For instance, you may want to pre-print invoices on the 25th of the month to be mailed out, and then come back later to add the charges on the 1st of the month.

An important note -- since some of these new options can result in some reservations having no new charges added, you should check the list to see if any have \$0 for the New Charges. You may not want to print invoices for those, or an adjustment may need to be made to your rates definitions or to the reservation's auto-charged-through date. To skip them easily, sort by New Charges and then highlight only those with non-zero charges before pre-printing invoices.

Another important note -- since the reservations listed is based on charged-through instead of paid-through, the New Charges for most or all of the reservations will change to \$0 after you click Add Charges (because the charged-through is instantly updated, and now they are charged in full). If you don't have the "Also include any paid-through..." option selected, with the same date as the bill-to date, all of those just charged will be removed from the list before you get a chance to print them. So, you either need to use the Pre-Print function first, before adding the charges, or you need to select the option to include any reservations not paid-through the bill-to date.

Printing Invoices, etc.

You can print invoices after adding charges, or you can pre-print invoices (show next month's charges without actually adding them to the reservations). You can also print mailing labels and envelopes if needed (these functions will take you to another dialog for printing mailing labels and envelopes, but will not close the monthly billing dialog). As with the other functions, you can select individual reservations to print if needed.

E-mailing Invoices

In addition to printing, you can E-mail (or pre-E-mail) invoices to those who have E-mail addresses. This works basically the same way as printing, using the Reservation E-mail list function to preview the list of reservations sending to, allowing specific selection if needed, which E-mail form to send, etc. As with the other functions, you can select individual reservations to E-mail if needed. If some of the reservations selected were not E-mailed successfully (e.g. they didn't have an E-mail address or you canceled part way through), then you will be given the option to highlight those not E-mailed so you can print physical invoices for just those reservations.

Finishing Up

Once you've printed the invoices and/or added the charges, there's nothing else you need to do -- just Close the dialog until the next billing time.

Find Receipt

The Find Receipt function is opened through Transactions / Find Receipt on the main menu. It can also be opened by pressing the **Ctrl-L** key.

This function is used to locate a previous receipt. This is especially helpful for returns, but it can also be used for other purposes. For instance, by entering an item description and perhaps a date range, you can get a list of all receipt line-items with that description. For P.O.S. inventory items, it can also look up receipt by inventory item code or description.

If you only want to search for transactions done through the P.O.S. sales entry dialog (assuming you have the P.O.S. option), then check the "POS Only" box.

There are three ways you can look for receipts -- by date, by receipt #, or by text. (A date search can be combined with a receipt # or text search). The text search will look for the specified text in the transaction "Item Description", or if it's a P.O.S. Inventory sale then it will also search for a matching inventory item code or item description.

After checking the appropriate options and entering text to search for, press **Enter** or click Search. All receipt line-items matching the criteria will be shown (thus a single receipt may be represented by many lines in the results).

If you want to view a particular receipt in its entirety, double-click on the line (or select it and press the View button). The P.O.S. dialog will open with all of the transactions in that receipt. From there, you can return items or print another copy of the receipt.

When you're done viewing and/or changing that receipt, the Find Receipt window will still be open in case you need to look at others.

When you're finished with finding receipts, click Cancel.

8 Other Reports

Overview

Specialized reports are found under Reports on the main menu. There are various statistical reports that are based on reservations, providing useful statistics to aid in managing and marketing your campground. In addition, there are Meter Reading reports for each type of meter (some or all may be disabled if not supported by your sites), Mailing labels, Envelopes, and Batch Receipt printing. To generate each report, start by clicking the appropriate menu item.

Transaction reports, such as reporting of receipts, charges, taxes, deposits, income, and so on, are accessed through the Transactions tab view. Therefore these are covered in the *Dynamic Interactive Report Screens* chapter instead of here. The Reports menu does have a "Transaction Reports" selection for convenience, however it's simply takes you to the Transactions tab view and opens the Summary Options, where the Quick-Reports are -- the same as if you clicked the Summary Options button on the Transactions tab view.

Common Reports quick-reference

Here is a list of some of the most commonly requested reports, and how to get them. Once you're familiar with these, many similar reports should be easy to figure out. For each report, be sure to select the appropriate date range needed in the From/To fields (or click "Today", etc).

Financial:

"Z-out" (daily receipts) -- Reports / Transaction Reports, click the "Receipts by Payment Method" Quick-reports button.

Daily sales -- Reports / Transaction Reports, click the "Receipts by Category" Quick-reports button.

Monthly sales -- Reports / Transaction Reports, click the "Receipts by Category" Quick-reports button. Then click "Summary Options", change the Summarize period to Monthly. Click OK.

Daily payment details -- Go to the Transactions tab view, put in Detail mode (Detail Options button, "Reset the view to details / all transactions"), then select "All Receipts" in the drop-down list next to the "Today" button so it only shows receipts.

Sales Tax reporting -- In most cases the Receipts by Category report should be used (see Monthly Sales above), assuming cash accounting, and assuming transactions are entered and categorized appropriately for your tax reporting requirements. See the section "Recommended Transactions and Reporting" in the *Working with Transactions* chapter, and see "Taxes Setup" in the *Maintenance Functions* chapter for setup and reporting procedures.

Income by Site -- Start with "Receipts by Payment Method" (Receipts by Category will NOT work). Then click on the Summary Options button, and change the "Group total for each" to Site. Change the Summarize period to Monthly if you like. Click OK. Note: If you enter advanced Deposits, they will be shown on the date the deposit was entered. If you want the report to reflect the actual date of the stay rather than when the money was received, click on "More Filters" and check the box to "Use reservation date instead of transaction date". This will report all revenue as of the First Night of each reservation.

Who owes money - Use the Payments Due tab, with "Show all with balances" checked. Alternately, use the On Site tab, with the "Balance" field selected under Options.

Deposits made for this year or next year -- Use the Arrivals tab view with the appropriate date range. Click on the Options button to select the "Deposits" column to show deposits made.

Inventory Cost of Goods Sold -- This requires the P.O.S. option and also requires entering inventory purchases and other adjustments through the program. Access this through P.O.S. / Inventory Reporting.

Inventory on hand (as of a date) -- This requires the P.O.S. option (and of course accurate "on hand quantity" entry and/or adjustments). Access this through P.O.S. / Inventory Reporting.

Reservations:

Who is arriving today -- Use the Arrivals tab view.

Who is in the park -- Use the On Site tab view.

Total # of people in the park -- Use the On Site tab view. Click the Options button to select the # Adults, # Children, etc as needed. Each column will show the total.

Canceled reservations -- Use the Non-Reserved tab view, with "*Any* cancelled" selected in the drop-down list at the top. Check Options to select whether it's showing by the date canceled or the arrival date of the canceled reservation.

Printing part of the Rack (e.g. for night staff) -- On the Rack view, check the box "Show Range" and enter an appropriate date range so it only shows those dates.

Reservations made today -- Reservations / Reservations by Date made.

All reservations for a given time period -- There are several options for this, depending on what you need to see for each reservation. Most likely the On Site tab will have what you need (select the date range, and select the fields needed under Options). Other report options include Reservations / Find Reservation (filter by date range only, don't filter by name, etc), Reports / Reservation Receipts, and Reports / Reservation E-mail List.

Statistical/Summaries:

How many sites are occupied each day (past or future) -- Use the Occupancy report, with "Show as percentages" unchecked (and optionally "Show total possible sites" unchecked).

How many sites are open each day -- Use the Availability report, with "Show as percentages" unchecked.

How many people are arriving each day -- Use the Arrival Statistics report, with "Show as percentages" unchecked (and optionally "Show total possible sites" unchecked).

How many reservations made each day -- Use the Date-Made Statistics report, with "Show as percentages" unchecked.

Report Dialog Controls

Each of the statistical reports is created interactively from a dialog. Just select the desired options in the dialog, then click the Generate Report button. You can then Print the report, or adjust the options to generate other reports. Whenever you have finished generating reports of a particular type, just Close the dialog. The last options you selected (except for the dates) will be saved for that report and used as the default the next time you open that report dialog.

The reports are grid-based summary reports similar to the Summary Transaction reports in the Transaction tab. Thus they use the same print option settings and have the same look. One difference is that there is no right-click menu in these report grids (but the common Grid Lines and Orientation options are available in the dialogs). Most of the controls in the three different report dialogs are similar, as detailed here.

Dates

You can select any start and end date for the reports, to filter reservations occurring in the selected date range. There are also helper buttons to quickly select Month-to-Date, Year-to-Date, Last Month and Last Year date ranges.

Summarize period

You can summarize the reports by days, months, quarters, or years. This results in one column (or row) for each day, month, or year of the selected date range. Keep in mind that the date range selected takes precedence. So for example if you summarize by month and selected the range 4/1/2001 to 5/1/2001, it will show April and May months in the report but will be reporting for only one day in May due to the 5/1/2001 ending date.

Site/Reservation Filtering

Most of the reports can be filtered by site type/class/park, and also by specific reservation details. This button will open the Reservation Filtering dialog and allow complex reservation selection and/or Site Filtering.

Note that the "Use filtering" box must be checked in order for the filtering to take effect -- this is checked automatically if you edit the filter, but you can easily toggle this option on and off to see how the filtering affects the report.

There's also an option to "Save filter" for next time, which can be checked when you set up a filter that you want to use as the default. If this is checked when you close the report, then the filter will be saved and re-used the next time you run the report (and "Use filtering" will be checked automatically.) If you make changes to the filter but this box isn't checked upon exit, then the changes won't be saved but the previous filter will still be loaded (but will no longer be used automatically -- just check "Use filtering" again to re-activate it next time).

Auto-Generate

By default, you must click the Generate Report before it will calculate a report and fill the grid, since some reports can take a significant time to generate. If you're reporting on a small date range or using a fast enough computer, you can select the auto-generate option so that the report is refreshed every time you change one of the options. This can be useful for experimenting with the controls to see how they affect the report before generating a report for a large date range.

Grid Lines

Any of the reports may have their grid lines turned on or off by checking or unchecking this option.

Dates on Top

The orientation of any report can be flipped with this option (uncheck it to put the dates in rows).

Hide groups with zero totals

The wording is slightly different according to each report, but the option does basically the same for each report. It will prevent showing group rows or columns (but not date summaries) that have no possible results for the entire date range. Each report treats this slightly differently. In the Occupancy report, it will hide any site types with no available sites in the date range (according to the other options). In the How-Heard report, it will hide any sources that had no reservations reporting that source. In the Unfulfilled Reservations report, it will hide any of the reservation statuses that had no reservations with the given status.

Show as Percentages

Any of the reports can show either percentages or total number of reservations (or reservation nights). When showing percentages, some of the totals may be an Average percentage rather than a Total percentage. (If they are totals, then they should add up to 100% for that row or column). If there are no possible sites/reservations for a given cell total, it will show dashes (---).

If not showing as percentages, each cell will have two numbers, in the form "80 / 95". The first number is the total number of reservations (or nights) for that value, and the second number is the total that could be possible for that date period (all available site nights for the Occupancy report, or all reservations for that period in the other reports). If there are no possible sites/reservations for a given cell total, it will show dashes (--/--).

Note: a space is included in front of the --/-- values so that it's not interpreted as a date when copied or exported to Excel.

Show total possible sites

This only applies if not showing the report as percentages, and when selected will show the values in fractional format (e.g. "3/6"). This is not by default, but it can be turned off so only the number (e.g. "3") is shown. This is helpful when the data needs to be exported to Excel, for instance, for further manipulation.

Count sites even if unavailable

When this option is available for a report, selecting it will include sites in the calculations for each date even if it's not available for that date, according to its season dates and/or special dates available or unavailable. (It doesn't matter whether the site was "open" on that date or whether had a reservation.) Since this can result in less meaningful results, such as in Occupancy reports, you can disable this so that a site is only counted in the total possible for occupancy for a given date if it's available for that date.

Exclude Guest and Owner reservations

This is checked by default, so that reservations with the "guest" and "Owner" type are excluded, to prevent occupancy from appearing larger than it should (since these can result in more than one Reservation on the same site at the same time). If you use these reservation types in a different manner than normal, or if you need to include them in your occupancy even though it can cause it to exceed 100% occupancy, you can uncheck this box.

Use all reservation nights (vs. arrivals)

For the How-heard Report and the Unfulfilled Reservations, you can generate statistics one of two ways. The two options can result in very different results, each of which have their advantages, but when the results each way are compared to each other it can be especially useful.

With this option selected, it will count each night of a reservation as a separate "hit", like a separate reservation with the given value or status for each night of the reservation. Thus a reservation lasting 30 nights would count 30 times, while a reservation lasting 2 nights would only count twice. This also means that a reservation starting in May and ending in June would count some for May and some for June in a monthly report.

With this option not selected, every reservation counts only once regardless of its length, and it only counts for the date on which it started. Thus a reservation starting in January and ending in June would only count once, and only for the January total in a monthly report. In fact this can result in many reservations that cover the report's date range being skipped entirely because they started before the date range. (However, this report is much faster to generate.)

The reason to check a report each way is to compare the results. For instance, when looking at "highway signs" results in a How-heard Report, a high percentage based on arrivals and a low percentage based on nights could mean that you get a lot of customers from highway signs, but they only stay a short time compared to other references. This revelation might even affect your advertising decisions because it creates a lot of work and expenses (checking them in and out, small credit card transactions, etc.) for smaller bits of income.

Print

Each report has a [Print](#) button which will print the current report. This may print just the grid, or print the requested envelopes, mailing labels, or receipts, depending on the report type. A preview will be shown before printing if you have the "Always preview reports" option enabled under [File / Printing Options](#).

Export List

Each report has an [Export List](#) button, which can be used to export the currently shown list/grid to a CSV file (see the *Exporting Reports* section for more details). This could be used to get the meter lists into a PDA for taking readings, or for exporting a mailing list to be used in another program.

Housekeeping Report

This report provides a list of sites or rooms that may need "housekeeping" attention due to a customer arriving and/or departing on a given day. It can also include all occupied rooms, in the case where all occupied rooms need to be cleaned.

For each site, it will show an "[Out](#)" and an "[In](#)" status so you can see at a glance what is happening with a site.

The [Out](#) column will show either Departing, Checked Out, or Occupied. It will be blank if the site was unoccupied last night.

The [In](#) column will show either Arriving, Checked In, or Occupied, or else it will be blank if the site will be unoccupied tonight.

Various options let you customize which site status you care to see, and if you need the extra information of Site Type, ETA, Reservation Type, and # Adults/Children/Pets (or whatever you're using those fields for). Note that the Reservation information will be for the arriving reservation, not the departing one.

You can also set a site filter to eliminate rooms which don't need housekeeping attention (meaning there is no check-in or check-out activity on the given date).

Note that "scheduled" sites, for instance those used for hourly reservations, will not be shown in the housekeeping report.

Site 'Dirty' handling

If the Site Dirty field is enabled, a column will show "*****" for sites with the "Dirty" flag set, plus some additional options will be available:

Hide clean sites - An option to Hide 'Clean' sites (those without the 'Dirty' flag set) will let you hide any already cleaned. This is different than the 'Hide sites with no housekeeping needed' option, because you could have sites 'Dirty' even if there is no check-in or check-out today. For instance, if you do cleaning every day for check-in guests, you can mark all of those sites as 'Dirty' (see the right-click functions) and get a report of all dirty sites (be sure to uncheck the 'Hide sites with no housekeeping needed' option to include continuous stays).

Right-click functions -- Several right-click functions are available for changing the Dirty status. Just right-click on the row for any site and a pop-up menu lets you change the status for that one site, or set multiple sites as dirty or clean -- based on whether there is a checked-in reservation, a reservation checked out, or a pending arrival, for instance.

Double-click function -- You need to be a little careful with this, but double-clicking on any row will change the status from Dirty to Clean or vice-versa. This makes it easy to update the list as sites are cleaned, for instance.

Occupancy, Availability, Arrivals & Departures Statistics

These four reports are very similar in usage, with the differences being only in the content of the reports.

Occupancy Report (and general options)

For the Occupancy report, it counts "site-nights", according to exactly how many days are occupied by a reservation. For instance if you do the report over a range of 7 days, then the value shown for each site could be up to 7 if it's occupied every day in the range. You can optionally **Include Reservation "Blocked to" dates** to consider "blocked" dates as occupied (e.g. for reporting future occupancy) -- otherwise it uses the First Night and Last Night of each reservation to determine the occupancy totals.

With **Show as percentages** selected, it will show the percentage of site occupancy (reservations filling the sites) for a given date range. The report can group the results by Site Type or Site Class, or show the results for each individual site.

When not showing percentages, but with **Show total possible sites (fractional format)** selected, you can see how many total site-nights were available for each period (sites times the number of nights -- for instance, 30 nights in a month times 100 sites would show 3000 site-nights). It also shows how many were filled for each period. This can help illustrate that 80% resulting from 8 out of 10 is not as significant as 80% resulting from 800 out of 1000.

You can select which site types or classes to report, which will affect the Average Percentage totals for a date period -- for instance if you exclude seldom-used site types like boat docks, your average for the period would more accurately reflect the actual occupancy average. Of course occupancy is averaged for each of the site types as well, so you know precisely how much of each site type is filled.

You can also use this report to check occupancy levels for future dates, since it will also count pending reservations already made for the future. (Note however that it can only count reservations that have sites assigned to them.) This can be useful for predicting and preparing for a busy season, or for seeing when you need to do more advertising to fill more spaces, perhaps by sponsoring a special event or sending out coupons in a normally slump period.

The option to **Count sites even if unavailable** is usually not appropriate, but might be useful to indicate what the overall occupancy percentage would be if you made them available the whole time.

The averages are calculated from the totals of all groups, so they are weighted accordingly. Thus you can see groups of 80% and 100% average out to 82% rather than the "expected" 90%, because there were more possible site nights in the 80% group than the 100% group.

This report shows Average percentages in both total directions (for all site types over the total date range, and for all dates of a given site type). There is no requirement for percentages to total up to 100% as in some other reports, since that can only happen if all sites are full for all nights in the range.

Filtering note:

If you don't use the option to **Exclude Guest and Owner reservations**, the results can be greater than 100% occupancy (or negative Availability) since these can result in more than one reservation on the same site. Day Passes are also included by default, which can artificially inflate the totals if grouping by Discount (they will show separately, e.g. in a "(no site)" group, if grouping by other types). Use the Site / Reservation Filtering if you need to exclude Day Passes.

Special Groupings

In addition to reporting occupancy by site type, class, etc., you can report occupancy by Discount Used and Reservation Types. These can be useful for statistical purposes, but note that when showing the total possible sites or percentages, the "total possible" for each grouping (e.g. for each discount or reservation type) will actually be the total of all sites available.

Also note that when grouping by Discount Used, the discount for any "future" reservations (any not yet checked in) is actually assumed to be the customer's first discount, if any. This is because reservations that haven't been checked in probably don't have the "Discount Used" field set yet, since charges haven't been added. (However if the Discount Used has already been set for the reservation anyway, it will be used.)

Availability Report

This report will show the percentage or quantity of sites available for a given date range. It's almost identical to the Occupancy Report, except that it's showing the "opposite" numbers -- e.g. if 90% of the sites are occupied, then 10% will be available. Actually this report is most useful when showing the # of sites available (instead of percentages), for future dates. It can be printed out as a quick-reference summary of availability.

Arrivals Statistics Report

This report is similar to the Occupancy Report, and has all of the same options and functions. The difference is that the Arrival Statistics report only "counts" reservations on their arrival date, whereas the Occupancy Report counts each date of the reservation's total stay.

The primary use for this report is to get a summary of the number of parties arriving each day. It could be considered a summary of the Arrivals tab view, showing only daily totals instead of the details of each reservation. Of course you can use it for other special purposes through filtering, for instance you could use the reservation filter to create a report showing how many parties arrived each day that are Good Sam members.

Departures Statistics Report

This report is similar to the Arrivals Report, and has all of the same options and functions. The difference is that the Departures Statistics report only "counts" reservations on their last date (or optionally the Block-to date), so you can see how many are due out each date or period.

Important: Since this report is based on the Last Night of each reservation (or optionally the Block-to date), remember that the dates shown are **not** the departure date -- for instance, the number shown for October 3rd will actually be the number departing on the morning of October 4th.

How-heard Report

This report shows you the sources of your customers. It will group the totals by each category you have set up in the How-heard pick-list. It can be useful to see which advertising methods are paying off. You can select which site types to include in the reports or other specifics through the Site/Reservation Filtering, so for instance you can compare results for full-hookup deluxe sites vs. electric/water sites (perhaps to see where the big-spenders are coming from).

The percentages are based on all reservations in each summarize date period, typically using the First Night of each reservation (or optionally all reservation nights, either to the Last Night or the Blocked-To date). You can also have it report according to the date each reservation was created. In addition to the percentages for each period, it will show an average percentage for all date periods combined (the entire date range). Since it also includes a category for "no info" (when no How-heard value is selected by the operator), the total of all How-heard categories should be 100% for each date period.

Unfulfilled Reservations

This report is useful for seeing how many reservations have been "missed" due to customer cancellations, inquiries that did not turn into reservations, and not being able to accommodate customers.

There are 2 ways this report can be grouped:

1. By Status (Type). It will report percentages (or totals) in the different Reservation Status categories:

Could Not Fill (the "couldn't book" flag on reservations)

Canceled (presumably cancellations by the customer)

No-Show (the customer did not show up)

No-Stay (the customer showed up but did not stay at least 1 night)

Mistake (an operator canceled it for some reason)

Canceled/Other (an operator canceled it for some reason other than those above)

Waiting List (couldn't book them but they wanted to know if something came available)

Inquiries (information saved but no reservation made)

Filled or Pending (either successful past reservations or booked future reservations).

The Filled or Pending category is included even though they were not unfulfilled, just so that the totals can be seen for proper perspective.

2. By **Cancel Reason** (as of version 11.0). With this grouping, it will categorize them by the "Cancel Reason" Pick List you've defined (plus an "(Unknown)" category for any that don't have the reason selected). Note that when this grouping is chosen, it will only include Canceled reservations, not other types like Inquiries, Could Not Fill, Filled, etc.

By default, it will report reservations based on their First Night (expected arrival date). You can alternately choose either the Date Made or the Date Canceled. Or you can also choose "Use all reservation nights", which will count each day of the reservation instead of just the arrival date.

Note that you can use this report to report on future dates as well as the past, which can indicate when you have a lot of customers already waiting for space (perhaps to prepare some extra sites to take on the demand). You can also have it report according to the date each reservation was created.

In addition to the percentages for each date period of each category, the average percentage for the entire date range is shown. Since all possible status conditions are covered, the Totals for all categories should be 100% for each date period, as well as the Averages.

If you don't select the Show as Percentages option, you will see the actual number of reservations (or reservation nights) for each of the categories, which can also be useful.

You can also select which site types to report or other reservation or site filtering criteria, which would allow you do make comparisons between cancellations of deluxe sites vs. economy sites, for instance.

Date-Made Statistics Report

This is very similar to the Arrivals Statistics report, so the details are covered in that section. The difference is that this report counts 1 for each reservation Made on the date, rather than on the reservation's arrival date.

Note that this report will typically include canceled reservations, etc, as well -- if you don't want those, then you can exclude them with the option **Exclude Canceled / Inquiry / Wait List** (or with the **Site / Reservation Filter**).

Meter Reading Reports

These are accessed through [Reports / Electric Meter Readings](#) (or [Water Meter Readings](#), or [Gas Meter Readings](#)). The three meter reading reports are identical except for which meter fields they report. Any of these reports may be disabled, if the corresponding Site Data Fields for meter support are disabled. They show the site name, the current occupant (the reservation scheduled for today, if any), the last reading date, and the last reading. Reservation access level is required to view this report.

These reports show the current meter reading as well as an input field to "batch" enter new readings (which can also be used for recording the readings on the printed report). If the Rates are set up properly for automatic charge calculation, this is the easiest and quickest way to add meter charges to reservations. It can also be used to adjust the readings for sites with no reservation.

Setting Up for Meter Support

Before using these reports, you'll need to have some things set up for meter support. Refer to the "Setting up for Electric, Gas and Water Meters" section in Maintenance for details on setting up the database for doing meter readings.

Report Settings

Show only sites with previous readings -- This is selected by default, which generally will be any sites that actually have meters. If you want to see all sites even if they don't have previous meter readings (such as when entering readings for the first time), uncheck this box.

Filter by last reading date -- This allows you to select a date range for the last reading. This is handy for getting a list of meters that need to be read (and customers billed) for the current day or week. By default, the start date will be 45 days ago and the end date will be 25 days ago, so it will show any readings up to 2 weeks "overdue" and any readings that will be "due" within about 5 days (assuming a monthly reading schedule). These dates can be changed as preferred, and the changes will be saved in terms of the number of days prior to the current day (so for instance the 45-to-25 days range is saved, not the actual dates).

Reservation types to show/charge -- Regardless of which sites are shown, you can select which reservation types to show on those sites. For instance, if you read all meters but only want to add meter charges to your Monthly reservations, then click Select Resv Types and select only the Monthly type. All non-monthly reservations will be hidden from the report (but the sites will still be shown). Therefore when new meter readings are entered in batch mode, the last reading of the sites with no occupant listed will be updated as, but no charges will be added to a reservation. If you want all reservations to be shown regardless of the type, then you need to clear all selections in the Resv Types list (which means no filtering). In addition, you can use this to disable all reservation types, in which case no reservations will be shown at all. You can do this to enter the starting meter readings before adding charges the first time, or if you simply want a reading report with no reservation information.

Actual date of reading -- If you don't have time to do all of the bookkeeping on the same day that the meters are read, you can set this date to effectively back-date the readings. Not only will it show this date in the site's "last reading" information, but it will also use this date to determine which reservation (occupant) should be billed for the electricity (whoever was in the site on that date), and also which meter rates should be used (if you have multiple rates that depend on the date).

There may also be other cases where you want to set the "actual date" -- for instance if someone checked out yesterday but you didn't check the meter until today, and now someone else has checked in that site, then set this date to yesterday so that the previous occupant gets charged instead of the new occupant. Likewise, if the new season rates take effect today but you want to give someone the previous electric rates for last month's usage, back up this date to use the previous rates.

Show / charge previous occupant (up to 31 days prior) if the site is currently empty -- This can be handy if you only read meters once per month even though the occupant might have left sometime earlier in the month. Of course it would have no effect if a new occupant is already in the site (in which case you need to use the "Actual date" setting above), but if it's at the end of the season and nobody new is coming in, then you can use this option to make sure charges go on the last occupant even though they're gone already.

All of the options above are saved in the database and will be used the next time you use any meter reading report (all of the meter reports use the same option settings).

By default the list is sorted by site, but you can change this to any order you like. Once you have the list showing what you need, you can print the list. There should be plenty of room left on the paper to enter the new reading, so it can be used as a walk-around list.

Show Previous -- This will add a column showing the previous reading and date. If a new entry has been added and Updated during this session (e.g. since you opened the report dialog), then it the reading form just

prior to entering it will be shown. If no new entry has been Updated, then it will check Meter History. If a previous History entry is found, it will be shown in gray with "History:" in front of it.

Before entering new readings -- Make sure it shows the expected Sites and Occupants

Before entering any readings, you need to make sure that all appropriate Sites are listed, and also that each site shows the appropriate Occupant (customer to be charged, if you're going to use [Add charges and update readings](#)).

If the Site is shown but Occupant is empty:

1. Verify that the correct Reservation Types are selected, or cleared -- The simplest thing to do is clear the Resv Types selection list (click [Select Resv Types](#), then click [Clear All Selections](#)). This will make sure it's not filtering *out* any types, so any reservation on the site for the appropriate date will be shown.
2. Make sure that a reservation is really on the Site during the correct time period -- Normally, it will show the occupant as of the "Actual date of reading" you have selected. So make sure that is set to the appropriate date, but also check the Rack to make sure the expected reservation is actually showing on that date (e.g. did not end too soon, or start after the date). If you do need to add charges for someone who checked out before that date, then select the option "Show / charge previous occupant" so it will show them (assuming they checked out within 31 days of the "Actual date of reading").

If the Site is not shown at all:

1. Try unchecking "Show only sites with previous readings". If the Site is shown now, that means it must not have a reading yet -- in which case you also need to manually set a "previous reading" for it -- see below for entering Manual Adjustments.
2. Uncheck "Filter by last reading date". The dates for may not this default to a range that works for you (see above for details), so it may be best to not use that option so it will show the Sites no matter when their last reading date was, as well as if they never had a reading done.

Right-click and double-click

Functions to enter readings or view details are available on the right-click menu -- click on any cell that's not empty, such as the Site Name or Occupant. You can enter new readings and add the charges to the current reservation, or enter manual adjustments without charging a reservation. You can also view site details or reservation details, or view meter reading history for that site.

Note that the double-click function is different depending on which column you click on and whether a reservation is shown:

Site Name -- Double-clicking in this column will open Site Details, where you can directly enter a meter reading without charging a reservation.

Occupant -- Double-clicking in this column will open Reservation Details. From there you could go to New/Edit Transactions to enter charges if desired (but there's a more direct way to enter meter charges, described below.)

Reading Date or Meter Reading -- Double-clicking on one of these columns will open a dialog where you can enter the new meter reading. However there is a slight difference depending on whether a reservation is shown. When the site has no occupant shown, you simply enter the reading and Save it, and the site's reading is updated. If there is an occupant shown, it will actually open the Transactions / Select Rates for the occupant's reservation and then the meter reading entry dialog. When you enter a reading here, the charges

will be added to the reservation automatically. For more information, see *Entering Single Meter Readings* below.

Batch Reading Entry -- Double-clicking in this column will simply put the cursor in that field so you can enter a new reading for batch processing (see below).

Entering Single Meter Readings

Manual Adjustments / Correcting the starting reading

You can manually adjust readings from the right-click menu (Site Details) or by double-clicking on any Site Name. This will open the Site Details dialog, where you can enter a new reading. Remember, however, that entering a reading this way will clear the reservation link so you won't be able to use the "View reservation read by" button, and also does not add charges to a reservation. This should **only** be used if you need to manually adjust the "previous" reading before entering a new reading for rate calculation.

Normal reading entry and auto-calculation

The Batch Entry method (below) is preferred even for single entries, but you can also select the Add Meter Charges to Reservation option from the right-click menu, or double-click on the old meter reading, to enter a meter reading and have the appropriate charges added to a reservation. This will take you directly to the Transactions dialog with Select Rates opened up to show the appropriate rates definitions for the meter (electric, gas or water as appropriate). If there is only one rate available, that rate will automatically be used and all you have to do is enter the new reading. Just enter the new reading, (and the actual date of the reading if it wasn't today), and press the "Done (auto-close...)" button on the meter reading entry dialog to immediately close the transactions dialog and get back to the meter list.

Note that meter wrap-around is handled automatically, as long as the correct wrap-around figure is set in Maintenance / Park Setup / Parks. For instance if the meter only has 4 digits and the last reading was 9900 but it now shows 0200, just enter 200 and it will know that 300 units were used.

If you need to enter other charges or want to print a receipt immediately, then instead of using the "Done..." button, click Save after entering the new reading. The Transactions / Rates dialogs will remain open.

You can also open the Reservation Details for the site's current occupant by double-clicking the occupant name. You will then be able to use that dialog's New / Edit Transactions button to add a meter charge for that reservation as above (it just takes a few more steps this way).

After entering a reading (or multiple readings), you can use the Print buttons at the bottom to print receipts, envelopes, or labels for all of the reservations with new readings.

Entering Multiple Meter Readings (Batch Entry)

When many meter readings need to be entered and charges applied to reservations, the batch entry method is quickest. Just click on the empty "Batch Reading Entry" column for the site -- the cell will be blue (selected) -- and type the new reading, then press **Enter** or **Tab** to step to the next row. The new readings will remain in this column and will be in a light yellow color. As with single readings, wrap-around is handled automatically (if the wrap-around is within a 25% range). An error will be shown if the figure you enter cannot be understood as either greater than the previous reading or a reasonable wrap-around.

If you have linked/synchronized reservations, you may have the option to Handle synchronized reservations individually. If this box is checked, the meter charges for each site will be added to the individual reservations. However, other charges for synchronized reservations are usually added to the Master reservation instead of

the individual reservations -- so to be consistent and avoid having to print multiple invoices, leave this option unchecked.

You can also select the date of the actual readings (using the "Actual Date of Readings" date entry). This will not affect the date of the charges (that will always be the current day), but if the meters were actually read on a previous day, select the appropriate date here so that the information is correct on the sites. (If some meters were read on different dates, enter readings from each day one at a time, set the reading date, and Add Charges... then repeat for each additional day, resetting the date each time.)

IMPORTANT: When using batch entry, make sure that the Occupant column shows the names for all of the reservations to be charged -- if no Occupant is shown for a site, then the reading will be changed on the site without adding any charges to a reservation. If you don't see all of the appropriate occupants, then you probably need to select the correct type(s) in "Reservation Types to show / charge" at the top. You may also need to check the "Show / charge previous occupant" box if you're trying to add charges to reservations that already checked out.

Once all of the batch readings are entered, click the "[Add Charges & Update Readings](#)" button. Charges will be automatically applied to each of the current reservation (if there is a reservation for the site of the appropriate Reservation Type it will be shown in the Occupant column), and the site will be updated with the new reading. A new "Charges" column will also be added to the report showing the charges that were added for each reservation. This is handy for verifying that your Rates are set up properly for it to calculate the correct charges (see below).

These steps may be repeated to enter more readings if necessary, just don't close the dialog before printing invoices or else it won't remember which ones need to be printed.

There are two Rates Setup requirements for adding meter charges automatically:

1. There must be one and only one meter rate defined (for that meter type) with the "Ask for meter reading" option that will apply to the current reservation on the current date. If there is more than one, an error will be reported and the reading will not be updated. Note that if you have multiple rates defined with different date ranges, it will use the one that applies to the current date, regardless of the reservation's dates.
2. There may also be one other meter rate that does not have the "Ask for meter reading" option. This can be used for a non-multiplying "base rate" that applies each time the meter is read, for instance if your charges require a \$5 per month base fee plus actual usage.

Note: Be careful about using batch entry to enter "adjustment" readings or charges for short-term customers -- when using the "Add Charges" function, it will assume that the current reservation in each site should be charged for the meter. So if the wrong customer is already on that site when the readings are entered, the charges will be applied to the wrong reservation. In this case you should find the correct reservation and go through its Transactions / Select Rate(s) to enter the new meter reading. Or if it's just an adjustment with no charges to be applied to a reservation, use the Site Details to enter the new reading.

Printing Invoices

After all of the readings are entered (using either the single or multiple method), you can print the invoices for all of the new charges, and also print labels or envelopes if needed. Using these buttons will open the appropriate dialogs to print Batch Receipts or Mailing Labels/Envelopes. Further options for printing can be found in those sections. As long as the Meter Reading report dialog is kept open, it will remember which reservations have new charges to be printed so you can use the print functions multiple times as needed. However if you do exit the dialog and come back in, then it will offer to retrieve the last set of readings/charges entered if you click the Print Invoices (or E-mail Invoices) button **before** adding any more new charges.

E-mailing Invoices

In addition to printing, you can E-mail invoices to those who have E-mail addresses. This works basically the same way as printing, using the Reservation E-mail list function to preview the list of reservations sending to, allowing specific selection if needed, which E-mail form to send, etc. If some of the reservations to be "printed" were not E-mailed successfully (e.g. they didn't have an E-mail address or you canceled part way through), then you will be given the option to keep those not E-mailed in the to-be-printed so you can print physical invoices for just those reservations.

Undo Readings...

This button will allow you to revert selected readings back to the previous value, e.g. if you made a mistake and need to start over, or you didn't have options selected properly to show the Occupants (so it skipped those charges), or if problems with the Rates caused the charges to be calculated incorrectly. If your Access Level is sufficient, it will also offer to delete any transactions that were added for the charges. Normally you would use Undo on the same day to fix problems -- however, since it tracks history you can even undo readings (and charges) later, if your Access Level is sufficient. (By default, nobody can Undo readings more than 7 days old.)

To use this, select one or more lines in the report (click on an entry to highlight a cell in the line), then click Undo Readings. (If the last reading was entered before you started using version 10.0, then this will not work since there will be no meter history.) After confirming the prompt(s), the previous reading will be shown. Now you can simply re-enter the correct reading.

Viewing Meter Reading History

You can view all previous readings entered using the [View Meter Reading History](#) button. (Meter History was not available in version 9.2 or earlier, so history will only begin as of when you upgraded to the next later version.) You can also right-click on a site and select "View Meter Reading History for this site". See the Meter History topic for details.

Meter History

Meter Reading History is recorded, tracking every change in the meter readings (excluding any entries done in version 9.2 and before, which did not have meter history tracking). Besides being handy for reporting and other historical purposes, this enhances the functionality of the functions through the Meter Reading report and batch entry -- e.g. allowing an "Undo" function to correct mistakes without having to re-enter all of the previous readings and deleting charges manually, and being able to bring up the last batch of entries to re-print or E-mail.

Meter History is accessed through the Meter Reading Reports -- open the report, then click the [View Meter Ready History](#) button (or you can use the right-click function on a site to view the history for that one site). (Access Levels determine whether you're able to view history.)

If initially viewing for all sites, you can select a single site to view with the drop-down list at the top.

You can also filter the report by date of reading (this uses the "Actual date of reading" used when entering the reading, not the date it was actually entered).

The "Usage" column will show the amount "used" as of that reading (e.g. the difference from the previous reading, if known). This won't be available for the first entry.

If the reading was entered through the Meter Reading Report and charges were added, you will also be able to see the amount of charges added for it, and of course the reservation that they were added on. You can select the line and click [View the Selected Entry's Reservation](#) to open the appropriate Reservation Details.

Customer Mailing Labels, Envelopes and Other Forms

The dialogs for printing mailing labels or envelopes and other forms are identical, they just print different formats. You can get to this report dialog from the main Report menu or from a right-click menu on many tab views (select the option to print an envelope or form for the selected customer, or print mailing labels/envelopes for all shown customers).

The default Mailing Labels are formatted to the industry standard "30-up" label sheet on Letter size (8.5" x 11") paper -- Avery numbers 8460, 8660, 8920, 8940, etc. While this format cannot be changed, if the labels don't print in the proper position then you may need to adjust the Printer Offsets in [File / Printing Options](#). Experiment with plain paper before using labels.

The default Envelopes are formatted for a typical #9 or #10 envelope, but can be sized to any envelope by changing the paper size and orientation in [File / Printer Settings / Envelopes](#) and the address offsets in [File / Printing Options](#). You will probably also need to change the Printer Settings for Envelopes to use Landscape orientation if you have to feed them end-wise, besides selecting the proper paper size (e.g. Envelope - #10).

In either case, there may be other form selections available from the drop-down list. The selections available depend on what formats have been set up in the Forms Setup, as well as the user's access level and the context of the report (customers, vendors, etc.). If the Form selected here is a custom form, and if you have sufficient operations access, then an [Edit Form](#) button will appear so you can make last-minute changes to the form if needed.

If you want the return address to also be printed on the envelope, you can enable that and set its position in [File / Printing Options](#). Note that if you have multiple Park records in your database, the return address printed for each customer will be from the park associated with its most recent reservation (the most recent being the last one actually created, regardless of whether the reservation is for a past or future date).

Filtering customers to be included

If you're preparing for a mass mailing of an advertisement, you should check the [Filter out "Exclude from Mailings" customers](#) box to eliminate those who do not want mail. You might also want to check [Filter out "Warning flag" customers](#) if you don't want to send to those that have a warning flag.

If entering this dialog from the main Reports menu, all customers will be shown in the list to print. If entering from a right-click menu on a tab view, then only those customers from that view will be shown. The [Filter out duplicate customers](#) box is checked by default, since tab views can often show multiple reservations for the same customer. Of course you can always uncheck this, perhaps so that labels and receipts are matched up properly even for those customers with multiple reservations.

You can also filter the customers to print by checking the [Use reservation, with optional filtering](#) box. (This check box is not shown if entering from a right-click on a view, since you're using reservations already.) First this will eliminate any customers that do not have reservation records (customers entered as guests, or who only purchased something in the gift shop, etc.). Then you can further filter the list with the [Reservation Filtering](#) button. Since this filtering is identical to the filtering used for batch-printing receipts, it is described separately below. Note that the filtering options are not saved once the report dialog is closed.

The total number of customers in the list is shown at the bottom. Also note that you can double-click on any line to get the Customer Details dialog, where you could fix an address, check the Exclude from Mailing flag (for instance on ones that have no zip code), or any other changes. The list will be re-generated with any updates you make.

If you would like to print out the list or export the list to a CSV file, use the [Print List](#) or [Export List](#) button. This will print or export the entire contents of the list in the dialog, just as it is shown.

Once you have them filtered as needed, you can trim down the list further by selecting only those customers to print. For instance, it may be handy to sort them by zip code (the default), and select only those records with zip codes. Use the multi-select methods to select multiple records (click / shift-click for a range, ctrl-click for individual lines). If none are selected, all will be printed (the same as selecting all records).

Customer Receipt options

If you're printing customer receipts, then you might want to only print recent transactions instead of their whole history. These options will be present only if printing receipts, not labels, envelopes or other forms. For details, see the Printing Reservation Receipts section that follows.

Finally, just click [Print](#) (or press **F8**) to print them.

Customer and Reservation E-mail Lists and Batch E-mailing

These functions, [Customer E-mail List](#) and [Reservation E-mail List](#), can be used to generate a list of customers with their E-mail lists. They are available in the [Reports](#) menu, but you can also get to them through the [Customer](#) menu (for Customer E-mail list) and [Reservations](#) menu (for Reservation E-mail list).

The same E-mail list dialog may also be invoked from right-click menus on many tab views (e.g. on the Arrivals tab view, right click and select [Print or E-mail for all shown reservations / Reservation E-mail List](#)). In that case, the list will be automatically filtered/limited to those reservations/customers currently shown on the Arrivals tab view.

As with the Customer Mailing Labels report, you can use the Reservation Filtering to select various criteria for which customers to be shown. Additional options are available to only show customers that have an E-mail address (or at least have an "@" symbol in the E-mail field), and also to exclude customers that have the Exclude from E-mail flag or the Warning flag set.

While Campground Master can be used to send mass mailings (see below), this list can also be exported to a CSV file for use in other programs to do the mass mailings. We recommend the software that we use for our own mailings -- GroupMail Plus, by Infacta. Go to <http://www.infacta.com> for more information. It can import the file created with the [Export List](#) button here.

Sending E-mails (Batch E-mailing)

Besides just getting a list of customer E-mails to print or export, this dialog is used to batch-send E-mails to the list. You can select 1 or more customers to E-mail (highlight the rows as usual), or send to the entire list (the default when none are selected). Of course this assumes that you have done the SMTP Setup so that E-mailing from Campground Master is possible, and that your Access Level allows sending E-mails to multiple customers.

When enabled, you will have some additional options available:

- **E-mail format** -- this drop-down list allows you to select which Form to send (and in some cases a "blank" option allows you to send a free-form E-mail, which you will type in after clicking Send). The Form selections depend on the situation (e.g. Customer vs Reservation forms), but the available forms depends on the enabled E-mail Forms defined in the Forms Setup. If you're in the Customer E-mail list function (as opposed to the Reservation E-mail list), then it will only show Forms that were specifically designated as Customer-based. That is, they can't have any reservation-specific information on them like a site number or dates, confirmation number, etc. While no Customer-based E-mail forms are defined by default, it would be appropriate to create Customer-based Forms for general messages like "thank you for your stay" or "upcoming events".
- **Edit Form** -- if the Form selected above is a custom form, and if you have sufficient operations access, then this button will appear so you can make last-minute changes to the form if needed (through Edit Form Definition).
- **Show... Transaction selections** -- if a form is selected that contains a transactions table, e.g. the E-mail Receipt, then you will have the typical options for what transactions to include just like for printing receipts.
- **Attach file(s) to E-mail** -- You can select one or more files to attach to all E-mails sent. This would be appropriate for a campground flyer, upcoming events calendar, etc.
- **Preview each E-mail** -- If this is selected, every E-mail will be shown to you before sending, so you can view and edit it as needed before sending, and they will be sent one at a time as you tell it. This of course is very slow and cumbersome if you send more than a few, but it's a good idea to do this with a few at first before sending to a whole list, so you can make sure everything looks correct.

Send Customer Emails (or Send Reservation E-mails) -- Finally, this button would be clicked to start sending the batch. A confirmation will be shown first, indicating how many will be sent. If you didn't have the Preview option selected, then it will start sending them quickly in "batches" with pauses between them, as defined in the Batch E-mail Options. For instance, it may send 10 at a time, with a 5-second pause between them. This is partly to allow you a chance to cancel during sending (during each pause period), but is also helpful in keeping your E-mail provider from flagging you as sending spam.

Resuming a batch

This information applies to the basic **Customer/Reservation E-mail List** report, e.g. entered through the main **Reports** menu or through the right-click functions on tab views. **Monthly Billing** and **Meter Reading** functions handle this separately, see those sections for details.

If a batch is canceled or stops due to an error, it will ask if you want to keep the unsent ones selected for re-sending. If you do, then those will be selected in the list, so all you have to do to resume is click the **Send** button again. (If you change what is selected and click **Send** again, then it will ask whether you want to use the new selection or the saved 'unsent' list.)

You may also need to exit this report function to make corrections before continuing -- don't worry, if there are unsent records then it will ask if you want to save those for next time. As long as you re-enter the report the same way again (e.g through the Reports menu, vs Arrivals, etc), and on the same workstation, then it will offer to re-select them again. Note that this also means it will keep a list of unsent records for each tab view separately. Also note that this list is workstation-specific, so each computer keeps track of its own list of unsent records for each tab view or report function.

General warning about batch-sending E-mails

Any time you send large quantities of E-mail, you risk being labeled as a "spammer" by your customers, your internet service provider, your E-mail provider (e.g. G-Mail), or any number of E-mail black-list organizations. Therefore we caution you to be very conservative with E-mail sending. Do your due diligence in finding out what restrictions your providers may have and study the general best practices discussed on the Internet. Limit E-mail sending to only recent customers who have a legitimate need to know about what you're sending them. We cannot be responsible for any issues that may arise from sending mass E-mails or for the content of those E-mails.

Reservation Receipts and Forms

This report dialog is similar to the mailing labels and envelopes dialog. You can get to this report from the main Report menu or from a right-click menu on a tab view (print a receipt for the selected reservation, or print reservation receipts for all shown reservations).

You can filter the reservations to print with the [Filtering](#) button. If entering this report dialog from the Reports main menu, it will show only reservations made today by default. Therefore if you print a batch of confirmation letters for reservations made each day, it's all set (but you may want to further filter out any that have already checked in if you have walk-ins). See below for details on the filtering dialog. Note that the filtering options are not saved once the report dialog is closed.

The total number of reservations in the list is shown at the bottom. Also note that you can double-click on any line to get the Reservation Details dialog, where you could make changes if needed. The list will be re-generated with any updates you make.

If you would like to print out the list or export the list to a CSV file, use the [Print List](#) or [Export List](#) button. This will print or export the entire contents of the list in the dialog, just as it is shown.

Once you have them filtered as needed, you can trim down the list further by selecting only those reservations to print. Use the multi-select methods to select multiple records (click / shift-click for a range, ctrl-click for individual lines). If none are selected, all will be printed (the same as selecting all records).

Once you have what you want to print selected, you will want to select the receipt format to print. See Receipt Types in the *Working with Transactions* section for details on the different types. There may also be other form selections available from the drop-down list. The selections available depend on what formats have been set up in the Forms Setup, as well as the user's access level. If the Form selected here is a custom form, and if you have sufficient operations access, then an [Edit Form](#) button will appear so you can make last-minute changes to the form if needed.

You will also have the typical options for what transactions to include just like for printing receipts.

Finally, just click [Print Receipts](#) (or press **F8**) to print them.

Reservation Filtering Dialog

This dialog allows a number of filtering options to aid in generating lists with Find Reservation, printing mailing labels and envelopes, and batch-printing of invoices or confirmation letters.

The first section is the date filtering. If selected, there are several different options for date filtering (only one date option can be used at a time). There's also an option to include only those NOT meeting the date criteria, for example to include only those *not* made during a particular time period.

Next you can filter by the length of stay. You can specify a range of nights or just a minimum number of nights (by leaving the maximum set to 0). Note that this only includes actual nights stayed or reserved, not blocked nights.

The next section includes options to include any that have a negative, positive, or no balance.

Next is an option to only include the "transaction master" for linked reservations. Use this for instance if you only want to include one reservation of a linked set, which would be the one that transactions are on (but that reservation must also match the other criteria, unless one of the "linked" options below is selected).

Next is a special section that allows a reservation to be included even if the reservation itself doesn't match the criteria, but a reservation that it's linked to does match the criteria. For instance, this option could be used if you want to include all reservations for a particular site plus any reservations linked to those.

If you need more advanced conditions, then you can also enter an Advanced Condition Expression. This requires knowledge of expression creation, part of the Advanced Customizations functionality. For instance this could be used to filter by a particular customer criteria like the warning flag, or some other reservation field like # of Adults.

Next, you can filter by the reservation type, reservation status, the discount used on the reservation, how they heard about your park, or why they canceled. You can make single or multiple selections in each list as needed. (Selecting none of the options in the list is the same as selecting all of them.)

Text Filtering -- Click this button to set up a text search so it only include reservations that have a data field matching certain text. See Text Filtering for details.

Site Filtering -- You can use Site Filtering to select the individual sites, site types, site classes, and/or parks to include.

To clear all filter selections (to do no filtering so all reservations in the database are included), click the Reset Filtering button.

9 Alerts, Work Orders, Journal, and the Audit Trail

Overview

Alerts and the Audit Trail entries are created automatically by the program. Work Orders and Journal entries are notes that you can create yourself. Each of these functions can be accessed through the View menu, for viewing system-wide reports. In addition, you will find Journal and Audit buttons on Reservation Details, Customer Details and Site Details, as well as Inventory Item Details and Vendor Details if you have the POS option. Work Orders for individual Sites can be entered through Site Details.

Alerts are generated when some error condition is detected that the user needs to know about and possibly rectify. These result in pop-up messages showing the details. They are also kept in the database for a period of time in case you need to go back and reference them.

The Journal is for making manual entries of notes. This can be done for the system in general, or for specific Reservations, Customers, Sites, Vendors, and Inventory items. How you make use of the Journal and what kinds of things you put in it is up to you.

Work Orders are essentially notes like Journal entries, but several additional fields make them functional for tracking whether the Work Order is complete, when it's due, when it starts, and who it's assigned to.

The Audit Trail is a detailed log showing different types of actions taken by the users. This enhances security and can aid in researching the progress of changes to a reservation, for instance.

Alerts

Overview

Certain "Alerts" can be generated by Campground Master, generally due to something happening behind the scenes rather than as a result of direct user action. For instance, the Hercules 2-way communications will alert the operator of something new received or of any issues that need to be addressed.

Alerts can also result when a problem with network synchronization is detected. If this particular type of alert needs to be disabled, then you can do so through the Network Setup / Diagnostics tab.

To keep annoyances to a minimum, an Alert will only appear after the operator is finished a current function (closed all dialogs) -- it won't appear in the middle of working on a dialog.

Alert Dialog

This is the window shown when there is a new alert (or when viewing an old alert from View Alerts).

It will show a message and a box with further details, if needed. A few different options may be present also:

Close / Skip Alert for now -- This closes the Alert dialog, but the alert is kept as "Active". However to view the alert again, you need to go to View / Alerts.

(Action) -- This second button will have a name appropriate for the action to be taken for the alert. This might be "Process", "View", or some other function appropriate for taking action on the alert.

Dismiss Alert -- This will flag the alert as "Dismissed". It's still in the system for reference (for a limited time depending on the Options), but is flagged so it won't show as a new alert.

View All Alerts -- This opens a list of all alerts (the View Alerts dialog).

Note that depending on the alert and your operator access level, some of these functions may not be available.

Viewing & Processing Alerts

Viewing current or past Alerts is done through the "Alerts" dialog, which is accessed through [View / Alerts](#), or from "View All Alerts" on the Alert dialog itself.

By default it will only show active alerts, i.e. those not "Dismissed" (assuming the current operator has permission to see active alerts). You can check the option to show dismissed alerts also if you need to see old alerts. They will be shown with the newest alerts at the top.

Here you can View the details of an alert, Dismiss one or more alerts, or even Delete selected alerts if you're sure there's no need to keep them.

To process the "Action" for an alert, e.g. take the action recommended for the alert rather than just dismiss it, you need to select the alert, click [View the Selected Alert Details](#), and use the action button on the Alert dialog.

The system-wide Alerts Options are also accessed through this dialog.

Alerts Options

This dialog is accessed through [View / Alerts](#), and then press the Alerts Options button on that dialog.

These options determine the number of days to keep alerts (generally an alert isn't needed once it's processed, but some history may be handy especially if support is needed in diagnosing the cause of the alerts). There is also a setting for a maximum alerts (to keep the database from getting flooded with alerts).

Also specify how many seconds of inactivity before showing an alert. This is to minimize "annoyance" when an alert pops up -- set it for 5 or 10 seconds, for instance, so that an alert won't appear while you're in the middle of a dialog or moving the mouse around working on something.

Note that there are also some Access levels associated with alerts (who can view them or take action on them, etc.) -- see [Maintenance / Park Setup / Access Levels](#).

Background Tasks (Threads)

The function [View / Background Tasks \(Threads\)](#) is strictly a diagnostics tool, and should be ignored unless technical support asks you to check something.

This will show status and prior activity of certain tasks that run in the background, such as auto-saving the database, auto-backups, full database refreshes, and certain report generation jobs.

Warning! Making any changes here, or in the [Configuration](#), could severely slow down your system! The default settings are designed to make the best use of the processor on that computer. Do not make any changes without consulting technical support.

As such, these functions are not documented in detail here.

Journal Entries

Overview

The Journal is for making manual entries of notes. This can be done for the system in general, or for specific Reservations, Customers, Sites, Vendors, and Inventory items. How you make use of the Journal and what kinds of things you put in it is up to you.

Here are the key features of the Journal entries:

- The View / Journal Entries function operates as a report as well as a way to enter System Journal entries. You can select the type of Journal entries to show (Main System, Reservation, Site, etc), and also filter by a date range.
- You can add any number of custom User fields, just like you can for Sites, Customers, etc.
- A "Journal" button is added to the various Details dialogs for Reservations, Sites, Customers, etc. This will open the Journal Entries list but will be limited to showing entries applying to that one record.
- From the Journal Entries list, you can Add an entry, Delete entries, View an entry details, or View the record (Site, Reservation, etc) associated with that entry.
- You can Print the list or Export the list to a CSV file, as with all other reports.
- Access Levels are available to limit access to various Journal functions (viewing, adding, editing, etc.)
- You could create a Color scheme that will highlight reservations or sites with any recent Journal Entries, for instance, or create a Query for Journal Entries to report them using your own filtering.
- When a Journal entry is added, it also goes in the Audit Trail (as well as any changes to the entry or if the entry is deleted).
- Journal entries are kept indefinitely by default (until manually deleted from this dialog, or if the associated record is deleted or Purged with old data).

Viewing Journal Entries

Journal entries can be viewed through the main menu's View / Journal Entries command. If done through that menu, the it shows the "Main system" journal entries by default, and you can also add or edit entries for the Main System. You can View and Edit the entry for any record type, however you can only Add entries for the Main System -- the Add button is only enabled if "Main system journal" is selected as the entries to show.

You'll also find a "Journal" button at the bottom of Reservation Details, Customer Details, Site Details, Vendor Details, and the Edit Inventory Item dialogs. This Journal button will take you to a list of any existing entries for that particular record, and will limit viewing to those. This is also where you would view the details, add a new entry or edit an existing entry.

Note that if viewing journal entries from Reservation Details, you'll have the option to also include the Customer record's entries. Likewise if viewing from Customer Details, you can opt to include journal entries from all of that customer's reservations.

Each entry is tagged with the date and time, as well as the operator who made the entry.

This list also function as a reporting tool, with filtering and sorting. All fields are shown except the Operator who made it (that can be seen for individual entry by Viewing it). If you accessed the list from the main menu (View / Journal Entries), you can choose to view the Main system journal, all entries for a specific record type (Reservation, Site, etc.), or to view All records. You can also filter entries by the date made, if desired.

Click on any column heading to sort by that column. You can Print the list or Export the list to a CSV file, as with all other reports.

Viewing Details, Adding and Editing Journal Entries

From the Journal entry list, use "View the selected entry details" (or simply double-click the entry in the list) to open a window with full details of an entry, for instance if it's too long to fully view in the list. This also shows the operator who made it. You can also edit an entry from this window if you have sufficient permissions.

To Add a new entry (assuming a sufficient access level), click "Add a new Journal Entry" from the Journal list. A blank entry will be created, where you can enter any length of note you like.

You can also add any number of custom User fields, just like you can for Sites, Customers, etc. In order to add the fields to this Edit Journal Entry dialog, you need to use Dialog Definitions in the Advanced Customizations, creating an Add-on dialog definition for the Edit Journal Entry dialog.

This dialog also has a Print button, which can print either a simple list of fields (the Journal Entry record in grid format), or a form created for Journal Entries. There are no standard forms defined for Journal Entries, but you can create your own through Advanced Customizations / Forms. You would create a Form with the "Other" Form Type, and choose "Journal Entries" for the Base Table. (There is also a sample one you can import to get started, called "Sample Forms - Journal Entry".) Once created, it will be available to select in the forms list when Print is used (any number of different Forms can be created).

Work Orders

Overview

Work Orders are for making manual entries of items to be done. These can be entered as "General" work orders (system-wide), or for specific Sites. While generally designed as a to-do list of tasks to be done, you could also use it to enter notes for the staff to review each day or a reminder system for later events.

Here are the key features of the Work Orders:

- Besides the primary Date (the date it was added), you can optionally track the Date Due, Start Date, and Done Date.
- Several of the fields can be disabled if preferred (see Data Field Definitions / Work Orders).
- You can also add any number of custom User fields, just like you can for Sites, Customers, etc.
- The View / Work Orders function operates as a report as well as a way to enter general work orders.
- A "Work Orders" button is added to Site Details, and a "Site Work orders" function is on the right-click menu for sites. Either one will open the Work Orders list but will be limited to showing work orders for that one site.
- From the Work Orders list, you can Add a work order, Delete a work order, View the details (any number of Notes can be entered for a work order), or mark work orders as "Done". Note that when marking it Done, the Done Date field will be set to the current day automatically (if that field is enabled).
- Access Levels are available to limit access to various work order functions (viewing, adding, editing, marking done, etc.)
- You can create a Color scheme that will highlight sites with any work orders not done, or create a Query for work orders to report them using your own custom fields and filtering.

Viewing Work Order Lists & Reports

Work Orders can be viewed through the main menu's [View / Work Orders](#) command. If done through that menu, then it shows the "General" Work Orders by default (not connected to a particular Site), and you can also add or edit General work orders. You can also choose to view just work orders for Sites, or to view All Work Orders. You can View and Edit any work order shown, however you can only Add "General" Work Orders -- the [Add](#) button is only enabled if "General work order" is selected as the entries to show.

You'll also find a "Work Orders" button at the bottom of Site Details. This button will take you to a list of any existing entries for that Site, and will limit viewing to those. This is also where you would view the details, add a new entry or edit an existing entry.

This list also functions as a reporting tool, with filtering and sorting. All work order fields are shown except the Time it was made and the Operator (those can be seen for individual work orders by Viewing it). If you add your own custom fields, those will also be shown. Click on any column heading to sort by that column.

It will initially list any that are not "Done". You can change that filtering to show all work orders or only those that are done. You can also select the type of work orders to show (General, Site, or All), filter by sites, site type, site class or Park if you're showing Site work orders, and also filter by a date range. The date range filter can be used for any one of the date fields -- Created, Done, Start, or Due. You can Print the list or Export the list to a CSV file, as with all other reports.

You can also mark multiple work orders as "Done" from here. Note that when marking it Done, the Done Date field will be set to the current day automatically (if that field is enabled).

Work Orders are kept indefinitely by default (until manually deleted from this dialog, or if the associated Site is deleted).

Viewing Details, Adding and Editing Work Orders

From the Work Orders list, use "View the Selected Order's Details" (or simply double-click an entry in the list) to open a window with full details of an entry, for instance if it's too long to fully view in the list. This also shows the operator who made it and the time it was made.

To Add a new entry (assuming a sufficient access level), click "Add a new Work Order" from the Work Orders list. A blank entry will be created, where you can enter any length of note you like.

The Short description of the work order should be a brief note like "sweep pad" or "fix pipe". If it's too long, it will make the report awkward. Any details needed can be put in the Notes field.

You can optionally enter the Date Due, Start Date, and Done Date. Note that the meaning of "Start Date" is up to you -- for instance it could be the date it's supposed to start, or the date that it actually started. Any of these fields can be disabled if you don't see a need for them, to simplify the screen (see Data Field Definitions / Work Orders).

The 'Assigned to' field is free-form text, so it doesn't have to be an operator name. This can also be disabled if you don't need it, or you could use it for something else like a company name hired to do the job.

There is a "Done" flag in addition to the Completed Date. It's best to only have this field (checkbox) enabled if you don't enable the Completed Date (and vice-versa), since a blank (unchecked) Completed Date also means it's not done. With both, it can be confusing. However if both are enabled, it will be considered "done" if it has a date even if the flag is not set, as well as if the flag is set even if there is no Done Date.

You can also add any number of custom User fields, just like you can for Sites, Customers, etc. In order to add the fields to this Edit Work Order dialog, you need to use Dialog Definitions in the Advanced Customizations, creating an Add-on dialog definition for the Edit Work Order dialog.

This dialog also has a [Print](#) button, which can print either a simple list of fields (the Work Order record in grid format), or a form created for Work Orders. There are no standard forms defined for Work Orders, but you can create your own through Advanced Customizations / Forms. You would create a Form with the "Other" Form Type, and choose "Work Orders" for the Base Table. (There is also a sample one you can import to get started, called "Sample Forms - Work Order".) Once created, it will be available to select in the forms list when Print is used (any number of different Forms can be created).

Audit Trail

Overview

The Audit Trail is a detailed log showing different types of actions taken by the users. This enhances security and can aid in researching the progress of changes to a reservation, for instance.

Typically, the audit trail is kept for only 1 year. If you want to keep older entries, you can set the length of time in the Audit Options. However, this also makes the database grow larger. You can also make a backup of the database each year so that copy will contain the previous year's audit trail if needed later.

Viewing the Audit Trail

The overall Audit Trail can be viewed through the main menu, [View / Audit Trail](#). When done from here, it will include all entries no matter what records are involved (this can be also be filtered, see below).

You'll also find an "Audit Trail" button at the bottom of Reservation Details, Customer Details, Site Details, Vendor Details, and the Edit Inventory Item dialogs. The Audit Trail list from these will be specific entries which affect that particular record. This may include related records -- for instance, the Audit Trail for a Reservation will also include any changes to its Customer, Transactions, and optionally any linked Reservations.

Note: Unlike many reports, there is no "Auto-generate" option for the Audit Trail-- you must click "Generate Report" before anything will show up. This is because it can take significant time to generate this report, depending on how much data you have and how many days past you're trying to view.

Before generating the report, select the date range, and More Filtering needed and options you want. Then click [Generate Report](#). If you need to make any changes to the filtering or options, you'll need to click Generate Report again to refresh the report.

Note that when viewed from a Reservation, the From date defaults to the Reservation's creation date (since there's no need to go farther back than that). For other record types, it defaults to one week, and if done from the main menu it defaults to only the current day.

What's in the Audit Trail -- To see what kinds of things are included in the Audit Trail, go to the Filters. There you will see a list of entry types. Note that the "record creation" type is only used for Operator records. Reservations and Transactions already have a field for Date Made, and other record types are not particularly date-sensitive.

A note about Field Changes -- It is assumed that any change from being "blank" to some other non-blank value is an initial value, not a change. These not recorded in the audit trail -- if there is no further change, then that value will still be found in the record. Only changes between one value and another (including a non-blank value back to blank) are recorded in the audit trail, so you will have a record of all past non-blank values that a field contained.

Viewing details -- If you need to see more details about a particular entry, select the entry in the list and click the button "View the selected entry details" (or just double-click the entry). The full text of the details can be seen, as well as more details of the record involved (if applicable). For some common record types like Reservations and Customers, you can also use "View the selected Entry's Record", which will open the appropriate Details dialog for the record responsible for that audit entry.

Once an entry is open (in "Audit Trail Entry Details"), there will be a button to **View Record's Fields**. If the entry is associated with a data record (and assuming the record still exists), that will open the record so you can see all of its fields in raw format, and will also show the Date/Time last changed for each field, if available. The date/time is only set for a field after it's initially set to a non-blank value, so this will be empty for any field that has not changed since it was initially set. Also note that this information is not available for changes made in versions 9.2 or earlier. The date/time information is primarily used for data synchronization and is not meant to be used for actual change tracking by users.

Editing entries -- Audit trail entries cannot be deleted or edited in any way, even by the highest level operator -- this would defeat the purpose of an audit trail.

Audit Trail Filtering

Viewing the Audit Trail is most useful if it's filtered for specific entries you're looking for. Of course if you only need entries for a particular reservation, for instance, then you should start by going to the Reservation Details of that reservation, and use the Audit Trail button there. Then it will be restricted to entries affecting that reservation.

Additional filtering is done through the Audit Trail dialog through the "**More Filters**" button. This allows filtering one or more aspects as described below. Note that if more than one aspect (selection list) is filtered, only entries matching ALL of the aspects will be shown.

Entry type(s) - Select one or more Audit trail entry types to view.

Record type(s) - Select one or more Record types to view. While all record types are shown here, most will not have entries (e.g. those related to setup and configuration functions, not day-to-day usage, do not generate audit trail entries).

Operator(s) - Select one or more Operators to view. Note that this list only includes current operator records, showing their current Operator Code. If an operator is selected here whose Operator Code has since been changed (for the given operator record), then entries related to that operator record are still shown. Therefore it's important not to re-use operator records for a different employee later.

Other Operator -- You can also enter an operator's code in this field, for instance to search for entries by an operator who has already been deleted from the system.

Workstation(s) -- If you network multiple computers, you can select one or more workstations here.

Text Filtering -- Click this button to set up a text search so it only include Audit trail entries that have certain text. Optionally it can even search the records related to the audit trail entry. See Text Filtering for details.

Audit Trail Options

Options to specify how long the audit trail is kept and how much is "current" vs compressed are accessed through the Audit Trail Options dialog. To get to this, go to [View / Audit Trail](#), and click the "Audit Options" button.

Compress older entries after ... days -- It's recommended to leave these settings at the defaults for most installations. In extreme cases of a very busy system it might make sense to keep less of the audit trail current/uncompressed, since compressing the audit trail saves about 90% of the space. The recommended defaults are to compress after 30 days, keeping 15 days current (so after the first 30 days, every 15 days it will compress the oldest 15 days, keeping 15 days uncompressed for faster access).

Compress in blocks of... bytes -- This can affect the effectiveness of compression in extreme cases. The smaller the block size, the less efficient it can compress, but anything above 25,000 won't make a lot of difference.

Permanently delete entries older than ... days -- For PCI compliance (for credit cards), this must be at least 366. If your business is not very busy, you might want to increase this since the database can handle more entries. In extreme cases, this may need to be made much shorter -- however, that means you must manually archive older entries to meet PCI compliance standards.

Manual compression -- This function can be used to manually compress entries, e.g. ahead of their scheduled time. This could be handy if you have a large amount of changes on a single day for some reason and want to reduce the database size.

Show Stats -- This simply shows how much memory the audit trail is using, which can be useful in deciding if changes need to be made in the settings. If the Current entries usage exceeds 1000 kB, then you may want to compress more often (keep fewer days current). If the Compressed usage exceeds 50,000 kB, then it's probably becoming an excessive burden on the database and you may need to have it permanently delete entries sooner.

10 Import and Export Functions

Overview

Campground Master supports a number of functions for getting data to and from other programs. While most smaller campground owners will find that Campground Master does everything they need, it can be useful for accounting to export the transactions into QuickBooks, or export reports or raw data to a standard format to be processed by other programs. Reports like the On Site report and Meter Reading reports can even be exported to a Palm or Pocket PC to use as a walk-around checklist.

The Import function can be used to transfer customer and reservation data from another system into Campground Master, to avoid retyping everything.

If your campground has a web site, then you may find the Export to Web function useful for showing your web site visitors what vacancies you have. Of course this is only as useful as you make it by updating the web site often enough, but if you want to take reservations through the web it can be very helpful. Note that this function is actually covered in the Online Reservations chapter instead of here, since it's related to online functions.

Campground Master can export to iCalendar files that can be uploaded to a web site and used by some services. See "Setting Up for Export to iCal" in the Online Reservations chapter.

Note that by default an operator access level of Manager or higher is required for any of the export functions, and only Administrators can use the Import function.

P.O.S. Note: If the P.O.S. option is enabled, then there will be an additional function for importing inventory/vendor data. See the Inventory Setup section in the *Point of Sale* chapter for details.

Importing Customer, Reservation or Transaction Data

The Import function can be found on the main menu: [File / Import / Import Customer/Reservation/Transaction data](#). You must have Administrator access to use this function.

IMPORTANT: Make sure you have a backup before doing the import, so you don't have to manually delete data if a mistake is made!

There are two primary requirements for the data to be imported:

1. It must be in either a comma-separated-value (CSV) or tab-delimited (text) format. If it's a CSV format, make sure that any fields with commas are enclosed in double-quotes, like "comma,comma" (this is the standard). If the field also has the double-quote character in it, then the quotes must also be doubled-up, like "comma,comma and a quote:"" embedded".
2. The fields must be in a form that equates to the fields in Campground Master. For instance, Site names (if importing reservations) must match either the Site Name (Full Name) or Abbreviation fields of the sites you've defined in Campground Master. There are some special-purpose import fields that can be used if the name is not separated into First/Last or if the City/State/Zip is all in one field.

Importing Customers vs. Reservations

Keep in mind that customers and reservations are separate in Campground Master. Reservations are "linked" to customers, but the customer data is in a separate table. Reservations also include the site number and dates of the reservation. Likewise, Transactions are separate but linked to the reservations.

You can import just the customer data from a customer list, or you can import the customers along with reservations at the same time if your import file contains the necessary information. You will see when defining the import fields (below) that there are two sets of fields -- one for Customers and one for Reservations. If you're importing just the customer data, then you will only select fields for customers.

If the import data has sites & dates information, then you can also import the reservations by selecting the reservation fields. You must have a first night and last night for the reservation, and preferably a site for it also (otherwise they will all be "unassigned" and you will need to assign each one to the appropriate site manually).

When importing reservations, it will first create a customer record (checking for duplicates), and then will create a reservation record for that customer. If your import data has multiple reservations for a single customer, that's fine -- it will create the customer only once, and will create multiple reservations for it.

Sometimes the data to be imported is separated into two separate files -- one for customers and one for the reservations. This will work as long as there is a unique identifier field for each customer (often called an "index" or "key"), and the reservation file uses that identifier as a link to the customer. Alternatively, if the reservation data has at least the customer's last name and first names, that can be used to link the reservations to the correct customer.

If there is a unique customer ID, then you will need to enable the "Cust Import ID" field so it can be imported. See Maintenance / Data Field Definitions / Customer Fields. Import the customer data file first, and be sure to import this ID field along with the other customer information. Then import the reservation data file, again selecting the customer Import ID field for the appropriate column so it can associate each reservation with the proper customer.

There is also a Resv Import ID in the Reservation fields. This field is important if you want to import transactions and the transactions are in a separate file from the reservations (assuming there's a reservation ID link for each transaction in the transaction data file). If this is the case, enable the Resv Import ID field and import it along with the other reservation data. Then use that field when importing transactions to identify the reservation for each transaction.

After all of the importing is done, we recommend that you disable the Import ID fields again since they're no longer needed. This will save space in the database.

Importing Transactions

Transaction importing requires some special handling, detailed below. Most likely you will need to create a special file suitable for importing transactions, so that the proper fields exist. The importing capabilities are limited to records with similar information and organization to Campground Master's transaction data, so this may require some custom programming to accomplish.

1. Transactions can only be imported if Reservations have previously been imported. If only Customer data is imported, Transactions cannot be imported because there must be reservations for the transactions to be assigned to.
2. Transactions must be imported separately from reservations, even if they are in the same file -- import reservations first, then start the Import over and import the transactions.
3. The import file must include the Reservation Confirmation # field for each transaction (and optionally the Site can be included), matching the imported reservations (and these must be assigned to columns along with the Transaction fields). Alternatively, it can include just a unique ID, or index, for the reservations. This is how the transactions are matched up with the reservations so they can be applied properly. Multiple transactions may be imported for each reservation as needed.
4. If the import file does not have the transaction Type and Category fields, all transactions will be assumed to be Deposits. As with other imported values, the Type and Category names imported must exactly match the one of the pick-list values in Campground Master. Of course a Total field is required as well for transactions, which is often the only thing imported, such as a deposit balance. If a Qty is available, a Qty field plus an Each

field can be used instead of Total (it will calculate one from the other as needed). The rest of the Transaction fields are optional.

Importing Customers from QuickBooks

You can import a customer database from QuickBooks accounting software using this same Import function. First you need to export the data from QuickBooks using its Export Addresses function: File -> Utilities -> Export Addresses. You may see a prompt for selecting the names to export, in which case you should select All Customers/jobs from the list (you don't need to vendors and employees, and probably don't need "other names"). Then click OK and enter a file name to export to, such as "Customers.txt". This will be a tab-delimited file that can be used for importing below, and will have appropriate address/city/state/zip information if you entered this data uniformly into QuickBooks.

The Import Process

There are several easy steps to importing.

- 1. Select a file.** You can enter the entire path to the import file, or use the Browse button. When browsing, it will look for .csv and .txt files by default, but you can change the file type to show all files if needed.
- 2. Select the file format.** Select either comma-separated or tab-delimited. Don't worry if you get it wrong -- the data will obviously look wrong when you import it if you choose wrong, and you can simply change this selection and do the Import again.
- 3. Load the file for preview.** Click the Load Import File button to read the data. The data is not actually added to your database yet, it's just loaded in the list on the dialog for previewing and editing.
- 4. Define fields to import.** If the file loaded successfully you should see the data in nice columns in the table. If the import file had headers in it, you'll even see the headers in the first line, like "first name", "last name", "city", etc. Now comes the important part -- you have to decide what each column means, in terms of Campground Master fields. This is usually pretty easy to do. Just right-click on each field (either the header or the actual data), and then select the field that corresponds to that column. Customer, Reservation and Transaction fields are listed separately, and there is also a separate list for Site Preferences (primarily used for preferences that might affect the charges, like 50A service). The column header will then change to that name so you know you've defined it. You don't have to assign fields to each column -- just skip any that you don't need or don't have corresponding fields. If you make a mistake, use the Remove function on the right-click menu. See the notes below for more details.
- 5. Select fields to use for duplicate-removal.** When the data is imported, duplicate customers will be automatically removed if possible. This not only applies to data you're importing, but also to any customers already in your database (it won't remove duplicates from your database, but it will avoid importing duplicates.) This requires at least a Last name and First name field (the data isn't much use without those anyway). You can also choose to check the Zip code field and/or the Address line 1 fields, to avoid filtering out common names like John Smith unless they live at the same place. If you uncheck these fields, or if they're not available in the imported data, then it will assume any that match first and last names are duplicates.
- 6. Convert names/addresses to mixed case or upper case.** Other programs may force or suggest that customer information be all upper case, which is easier to enter but is not as professional looking on receipts, and also takes up more room so less information can be shown on the Rack before it has to be truncated. So you may want to decide to start entering the information in mixed-case, and you can also have the import function convert the old information. Conversely, you can make sure that all of the old information is in upper case if you wish to keep with that procedure. Note that this only affects the data during this session, not data already entered or previously imported into Campground Master.

7. Edit data if needed. The preview list is fully editable, so you can delete any records that you don't want to import (like obvious duplicates or blank records), and you can even enter corrections as needed here before importing. Just click on a field to select it and start typing to replace it, or click twice to edit the value without replacing it. Likewise, just click any field on a row and click the Delete Selected Records button to delete the record. (Ctrl-click for multiple selection also works.) Note that if the import file included a header row with field names, you should also delete that row so you don't get a customer that's just the field names.

8. Import the data. When everything looks right, click the Import Data! button to perform the import. You may see an error or warning prompt about duplicate filtering or field definitions if there seems to be something missing. As the data is imported, you will see customer/reservation totals and a duplicate total count up at the bottom.

Handling Errors -- When the import is complete, all records imported are removed from the list, but there may be some records left over in the list and a message saying that some errors were detected. To see why a record was not imported, just hold the mouse over the record in the list -- an error message will be shown with the reason for the error. Errors are typically a result of records that don't have a last name (required by Campground Master), or for sites that weren't recognized (if importing reservations), or dates that were not formatted properly. You can ignore them and close the dialog, or you can manually edit the records and run the Import again, as many times as needed to get them all imported. It's also common to have errors if you're importing Pick List fields like Rig Type, if the imported value doesn't match one of the values in your Pick List (see below for more details).

When all is finished, just Close the dialog -- the data is imported to the database and the reports will be refreshed if necessary.

Notes on Importing Reservations

Reservations are tricky to import because many of Campground Master's reservation data fields are unique, and the software must make certain assumptions. As mentioned above, the primary criteria is that the site names must match. If this isn't the case and you have a lot of reservations you would like to import, you might adjust the site names temporarily to match the data to be imported, and then change them back. (Using copy/paste to and from a spreadsheet like Excel can make it easy to change them back to what you want after importing the data.)

IMPORTANT: If you don't assign a field to be the site name, or if the site name for any reservation is empty, then the reservation will be made "unassigned" and you will have to assign the site yourself after import. If the reservation has a site name but it just doesn't match one in the database, it will not be imported and will be left in the list as an error.

The dates must also be formatted properly, and the imported data must contain at least a first and last date. It's also important that you know whether the "last" date is the "Last Night" the way Campground Master defines it, or if it's the "leaving" date (Last Night + 1). You can choose either Last Night or Last Night+1 for that import field accordingly. If there is "extra" data after the date (some programs export a time-stamp after the date), that's fine -- anything after the first blank space ignored. (There's one exception -- for the "Date Made" reservation field, if the time is detected in the same field after the date, that will be used to fill the Time Made field automatically.)

The date order (mm/dd/yyyy or dd/mm/yyyy) will be assumed to follow your computer's international date settings -- for instance in Canada, the date is assumed to be dd/mm/yyyy. There is a little flexibility in the date format -- for instance, dashes or periods can be used instead of slashes, and there doesn't need to be leading zeroes or centuries (e.g. 1/3/02 is fine). The date can also have the year first as long as it's 4 digits, e.g. yyyy/mm/dd or yyyy-mm-dd (in this case the month is always assumed to be 2nd). The date can also be in "long" format, with the month name (at least the first 3 characters of it), the day of the month, a comma and the year as 2 or 4 digits. For instance, "July 5, 2005" or "Oct. 10, 05".

Since reservation status cannot generally be imported unless the imported status names match the Campground Master status names (except in the case of ReserveRight or GuestTracker), the program will assume that any reservation ending prior to today is checked out, and any reservation starting after today is pending. Any that cross today will be checked in automatically. Of course none of these will have transactions, so transactions will have to be added manually if needed. The "operator" field for check-ins and check-outs will be set to "(imported)", and the date/times for the operations will be set to reasonable values (the check-in date will be the actual start date, check-out date will be the end date). If a confirmation number is not imported for a reservation, then one will be generated for it.

If the imported file contains multiple reservations for the same customer, then duplicate customers will be "merged" properly and the reservations will be applied to a single customer (according to the duplicate-filtering rules mentioned above). Likewise, if the customer already exists in the database, the reservations will be added to that existing customer.

Duplicate reservations are also detected to a certain extent. It will check for a reservation with the identical site, dates, customer, and type, in case the same reservation was already imported from a different record. Other fields are not checked, it simply assumes that the same customer could not have two reservations on the same site for the same dates.

Some fields can be selected more than once, and the data will be combined into the one field in Campground Master. For instance, any data that doesn't have a direct import correlation can be imported to the Reservation Notes or Customer Notes fields. Each imported field will be added to a new line in the Notes. Likewise you can combine license number & state fields into the single license field in Campground Master, or add multiple First Name fields together.

IMPORTANT: No conflict-checking is done when importing reservations, except checking for duplicates! If you already have reservations entered that conflict with imported ones, or if the imported data contains conflicting reservations, you will have to sort these out manually after importing. The Conflicting Reservations report under the Reservations menu will be helpful for cleaning these up.

Hopefully everything will go well and you'll have all of the necessary details to get started. Of course a lot of the things normally entered in Campground Master may not be there for the imported reservations if the imported data doesn't have the information (like how-heard, reservation type, etc.), but the essentials will be there to get you started.

Exporting Reports and Data to Other Programs

Any of the Tab View reports, as well as almost any report grid in a dialog such as Find Customer, can be exported. You can also export any of the raw data tables found in the [Maintenance / Raw Data Tables](#) functions.

There are two ways to get the data in another program -- through Copy/Paste, or with the Export to CSV function.

Copy/Paste

To copy data directly to another program such as Excel, just highlight the desired cells on any grid report (or press **Ctrl-A** to select all cells), then **Ctrl-Insert** or **Ctrl-C** to copy to the clipboard. Then switch to the other application and paste the data. The data is copied in Tab-delimited format, so it can be pasted into nearly any program that supports Tab-delimited data or text. However, only the data cells can be copied this way, not the header row and column. To get the entire report into another program, use the [Export to CSV function](#).

Exporting to Tab-Delimited Format

As mentioned above, when data is copied from a grid it's already in tab-delimited format. Thus you can create a tab-delimited export file by using the copy function above, then open Notepad or any text editor, and paste the data into it. Then save the file as a ".txt" file. However, as mentioned above, this will not contain the header rows or columns. To get the headers you must use the CSV export function below.

Exporting to CSV Format

"CSV" is a common file format, which stands for "Comma Separated Values". You can export any of the grid reports to a CSV file which can be loaded into a spreadsheet like Excel, or loading into a PDA like a Palm or Pocket PC. When a report is exported to a CSV file, it will contain all of the data and also the headers, just as shown in the current view or dialog grid.

To begin the export, either use the Export Current View option on the File menu (this is used for any tab view report), or click the Export List button on any of the other dialogs that have a grid-type report. Alternatively you can press **Ctrl-F10**, which will work for any of the supported reports.

Next you will see the standard file dialog. Just enter the filename and select the location (navigate to the desired folder) and click Save. The file will have the extension ".csv" so it's recognized by other software as a CSV file.

To get the data into your other software, you'll need to locate the appropriate function. This is usually an "Import" function under a "File" menu, but programs can vary.

If you want to load the exported data into a Palm PDA, you will need to use a 3rd-party program that can read CSV files. Many such programs are available. We recommend a popular program called MiniCalc, which sells for around \$30.

Technical notes: To ensure that data with commas is imported properly, all fields are enclosed in quotes. Most CSV import functions will remove the quotes properly. Also, if the data itself includes the double-quote character ("), these will be doubled up in the text, e.g.: **quotes(")** becomes **"quotes ("")"**. This is the CSV standard for dealing with commas and quotes within the text.

Exporting Transactions to QuickBooks

Overview

This feature allows you to export the Campground Master transaction data to a file that QuickBooks can import (IIF format). Transactions can be exported as often as daily (daily totals are exported), or it can be done once a week, once a month, or however often you need the data in QuickBooks.

Only daily account totals are transferred to QuickBooks -- not individual transactions or invoices, or customer totals, or inventory sales.

All of the charges will be transferred by transaction category, and all of the receipts will be transferred by payment method. The daily totals can be exported to QuickBooks either as General Journal entries for each category and payment method or as a single Cash Sale transaction with line items breaking out the category details.

If you have accounts receivable (e.g. you add charges to reservations before payments are received, such as monthly rent), you can have the A/R balance go into an Accounts Receivable account in QuickBooks. If you take advance deposits, they can also be assigned to a separate QuickBooks deposits account until they're applied, to track deposits as a "liability" against the actual receipts.

Using the QuickBooks Export Function

To begin the export process, open the Export dialog from File / Export / Export Transactions to QuickBooks. This dialog contains all of the setup and options needed for exporting. Generally you only need to do the setup and set the options the first time, and thereafter you only need to verify the date range and click the button to do the export.

Note that if you already use QuickBooks, you may want to base your Pick List setup for Transaction Categories and Payment Methods according to your QuickBooks accounts, to make the transactions in Campground Master map easily to your existing accounting system.

QuickBooks Preparation

Before getting started on the Campground Master side of it, you should have the following accounts set up in QuickBooks (some of these are probably already there):

- **Undeposited Funds** account (type: Other Current Asset)
- **Accounts Receivable** account (type: Other Current Asset (older versions can use Accounts Receivable type, but as of QB 2019 this will not work))
- **Advance Deposits** account (type: Other Current Liability)
- A number of Income type accounts where the Campground Master's charges will be transferred. This can be separate accounts or it can be Inventory Items in one or more Income accounts. If not using "Handle taxes separately", you'll also need Income type accounts for any taxes collected.
- If using "Handle taxes separately:"
 - One or more Other Current Liability type accounts where the Campground Master's **taxes** will be transferred. Or if you're not using the option to handle taxes separately (see below), then these should be Income type accounts.
 - Also, you need one or more Items associated with sales taxes account(s) above (Item type "Sales tax item").
 - In addition, you'll need a Vendor set up for sales tax (possibly more than one vendor, for instance one for Sales tax and one for Lodging tax, depending on your reporting needs).
- One or more Other Current Asset type accounts for your credit card merchant(s), where credit card payments will be mapped into. You may also want other bank accounts corresponding to various Payment Methods in Campground Master, but you can also use the general Undeposited Funds account mentioned above for cash and checks.
- Also add a Customer called "Daily Sales", or perhaps "Campground Master Sales", to be used for the imported transactions. This will be used for all of the data imported from Campground Master. Go to Customers / Customer:Job List to add one in QuickBooks.
IMPORTANT: Add the customer in QuickBooks **before** doing an import, or else it will be created automatically during import but it will not be set up not correctly.

Now you need to export the QuickBooks lists so Campground Master can use them. Select from the menu: File -> Utilities -> Export... (or in later versions, File -> Export -> Lists to IIF). An Export dialog will open where you select the lists to be exported. Export the following lists:

Chart of Accounts
Customer List
Vendor List
Item List

Click OK, then select a location for the export (IIF) file that you can remember, and enter a name for it. Click Save, and when it confirms that the export is complete you can return to Campground Master.

Step by Step -- Export to QuickBooks Setup in Campground Master

Although you need to do this first before exporting, it's at the bottom of the Export to QuickBooks dialog because you only need to do it once (unless you change configurations in Campground Master or QuickBooks, requiring different account mapping).

1. Import accounts...

You'll need to import the lists file created above (in QuickBooks Preparation) before setting up the other account mappings. You could skip this and type all account names manually, but besides being error-prone that would take much longer.

This is done inside the Export to QuickBooks dialog -- it's not a separate import function in the Campground Master menus since the it's only temporary, for setting up the QuickBooks mappings. You will need to import these again each time you need to use these setup functions (but you don't need to do the export from QuickBooks again unless the accounts change there). Click the button "Import accounts, etc. from QuickBooks" (in the Setup section of the dialog), and navigate to the file you just exported from QuickBooks. Open that file, and the lists should be imported almost instantly. You can tell if they imported correctly by dropping down one of the lists in the Setup area -- if it's not empty, then the lists were imported.

IMPORTANT -- These are imported temporarily only! If you close Export to QuickBooks dialog, you will need to do the Import accounts again the next time you need the lists the Setup functions (but you don't have to export the lists from QuickBooks again unless changes to accounts are made -- just import the same file again). The imported QuickBooks lists are only kept temporarily, since they aren't needed by Campground Master once the setup is completed. However, if the previous import file still exists, then it will be re-imported automatically each time you open the this dialog. So you may only need to re-import manually if you make changes to the QuickBooks lists and export a different file from QuickBooks.

2. Select the Export Method

Before setting up the mappings, you should decide whether you're going to be using the General Journal export method or the Cash Sale export method, since some setup parameters will be affected by this. While you can change this at any time, it's a good idea to choose one method and stick with it, for consistency.

- We recommend using the **Cash Sale** method -- select that method and continue on to the next step unless you need to know the details of how they work.

The Cash Sale method will create a single Cash Sale in QuickBooks for each day (or you can combine all days into one, but this is not recommended). This is just like creating a Sales Receipt for a customer. The charges will be added as Items sold, using the Items mapped to transaction categories, and receipts will be added as negative entries on the sales receipt, itemized by payment method. If you're using auto-taxes for any of the accounts in QuickBooks, it will also include the applicable tax entry.

Quantities can also be included when using Cash Sale, so for instance it will show how many daily rates, weekly rates, extra adults, etc. make up the total. A calculated "Rate" will also be shown, but this is only useful if each of your transaction categories represents a uniquely priced item. Otherwise the Rate is just an average (and only accurate to 4 decimal places, though this does not affect the accuracy of the totals).

Deposits, Deposits Applied and an A/R balance adjustment will also be added as entries in a manner to make the total value for the sale balance out to zero. (This is because QuickBooks cannot handle a negative sale, which could happen on occasion if the day's sales and receipts don't balance.) Optionally, you can leave out mappings for some of the Receipt payment methods such as Cash, Checks, and Traveler's Checks. In this case, the balance should be the total receipts for these, and thus you can use "Undeposited Funds" as the account for the Cash Sale to have these receipts automatically go into undeposited funds. (You would get the same result by mapping them to Undeposited Funds and letting the cash sale balance out to zero, except that would result in multiple entries to undeposited funds instead of just one.)

One advantage of the Cash Sale method is that you can easily see daily activity snapshots in QuickBooks, by browsing the Cash Sale receipts. However this may just not make "sense" for your accounting methods, in which case the Journal entries can be used.

Note that Misc. Income and Expense transaction types are always exported as individual Journal entries, even if you use Cash Sale for the export method. This is because they are not the customer charge/payment transactions, and should be transferred individually just as they were entered. Actually, if you use QuickBooks for your accounting then you should probably **not** be using Campground Master for Expense transactions or Misc. Income -- those would be better suited for direct entry into QuickBooks, which can record more detailed information about them.

Alternative method: The General Journal entries method will create a pair of journal entries for each transaction category (for charges) and each payment method (for receipts), in addition to entries for deposits if applicable. All entries go through Accounts Receivable -- that is, every charge entry is treated like an A/R amount, and every payment entry is a payment against A/R. The net difference is essentially the change in your A/R balance for the day, and will be reflected in the QuickBooks A/R balance accordingly.

This method is not used very often because the imported information is not in a very "user-friendly" form, although it is the "simplest" method in terms of a straight transfer of transactions, and is usable if your Transaction Categories map directly to QuickBooks "Income" accounts. However, journal entries don't allow QuickBooks "Item" info from the mappings to be used, so if you use Items in QuickBooks for your different categories of sales, then the Cash Sale method will be a better choice.

3. Option to use Non-US date format:

Normally the U.S. date format, month/day/year, is used in the export file. In some versions of QuickBooks in some countries, it may be necessary to select this format to export the data using the local (non-U.S.) date format, so it's in day/month/year format.

4. Select Customer:

- Select a QuickBooks Customer to use (e.g. the "Daily Sales" customer created in the QuickBooks Preparation above).

IMPORTANT: Add the customer in QuickBooks **before** doing an import, or else it will be created automatically during import but it will not be set up not correctly.

This is particularly important for the Cash Sale export method, but is also required for the A/R entries when using the General Journal export method. Generally this is just a dummy customer created in QuickBooks like "Campground Master Sales", as created above in the QuickBooks Preparation section. If the customer has address information, that will appear on the sales receipt in QuickBooks.

5. Account for Accounts Receivable balance:

- Select an account to use for Accounts Receivable (e.g. the "Accounts Receivable" account mentioned in the QuickBooks Preparation above).

This is required to be "Accounts Receivable" when using the General Journal export method. If using the Cash Sale method, it can be any account you want to use for any "balance" for the sale. As mentioned above, using an account of type Other Current Asset is recommended (using an actual Accounts Receivable account will not work for QuickBooks 2019 or later).

Important Note: Be sure that all Receipt Payment Methods are mapped to an account (or at least all mapped to Undeposited Funds). Any difference between the mapped Transaction Categories (Charges) and mapped Receipt Payment Methods will be considered a change in the A/R balance, resulting in a zero net change for the day (basically the A/R keeps things in balance -- if you didn't get paid for something, the difference must be A/R). If using the Cash Sale method, this means that the total of the cash sale will always be \$0.00.

6. Account for Deposit Balance (optional):

- Select the account for your deposits balance here (e.g. the "Advance Deposits" account created in the QuickBooks Preparation above).

If you accept advance deposits, you should track those separately from other payments (usually as an "Other Current Liability" account in QuickBooks). In fact if you enter "Deposit" transactions in Campground Master at all, this must be set up or else the Deposit transactions will not be exported to QuickBooks. If you don't have an appropriate account set up, simply create an Other Current Liability Account named "Advance Deposits" for this purpose.

Campground Master will keep the Deposits account in QuickBooks up to date by adding any new Deposits and subtracting any Deposits Applied, and the deposits will also be added to the appropriate receipts accounts (e.g. check, credit cards, etc.) when they are received. This helps keep things in balance even though the charges have not yet been entered to offset the deposit received.

7. Account (for Cash Sales):

Select an account to use for the balance of cash sales (e.g. the "Undeposited Funds" account mentioned in the QuickBooks Preparation above).

If you're using the Cash Sale export method, you need to select an account to receive any remaining balance. If you map everything properly, there really shouldn't be any balance, but an account is still required. You can use Undeposited Funds (as mentioned earlier), or create an "Unknown balance" account to catch any unexpected imbalance, or use some other asset account (some accounts may not be allowed by QuickBooks).

8. Show Qty for each charge:

Check this box if you want the Sales receipts to show a Qty in addition to the amounts. Note that the qty is not necessarily useful depending on the situation, but in some cases it may be helpful.

9. Include payment method for receipts:

- Check this box if you want to include the Payment Method for any Receipts transactions (assuming the Receipt Payment Method mapping is done).

Note that this uses the Payment Method names from Campground Master -- there is no option to map them to different names for QuickBooks. However QuickBooks will add any unrecognized names automatically. Checking this option is an easy way to get the appropriate pay methods to be shown in QuickBooks when you use the Deposit function under Banking, assuming that you're mapping each of the receipts into Undeposited Funds rather than directly into a bank account. Refer to the Receipt Payment Methods Mapping section below for more information

10. Mappings

Now for the tedious part -- you need to map every Transaction Category (almost) and Payment Method (possibly twice) to an appropriate QuickBooks "Account" or "Item". Details are found in the sections that follow, but here's a checklist:

- Taxes Mapping for Auto-taxes (Cash Sale method only). Note that to use auto-taxes, you also need to check the **"Handle taxes separately from charges"** box below the Taxes mapping button -- in most cases this must be checked for things to work properly.
- Transaction Categories Mapping
- Receipt Payment Methods Mapping
- Expense Payment Methods Mapping (if you use any Misc. Income or Expense transactions in Campground Master)

Preparing to Export

Now that everything is set up (and should be saved so you only need to do it once), you just need to select the dates to export, whether to combine the dates or not, and the location of the file. Although the file name and all/single options are saved each time, these should be double-checked every time you export just to be sure.

The dates will default to just today. This works well if you export at the end of every day, but that probably won't always be the case. Just change the dates for the range of transactions you need to export. Keep in mind that these are really transaction dates, not reservation dates.

If you choose to Export all as a single date, the transactions will be totaled only once for the entire date range, and only one set of transactions will be exported. If you don't care about daily reporting and just want to minimize the number of entries each month, then this may be what you want to do. However be careful about overlapping dates into 2 or more exports, which would result in duplicate reporting!

If you choose to Export each day individually, then the transactions will be totaled separately for each date in the range. The results will be exported either as a Cash Sale for each date or a complete set of Journal entries for each date, depending on the export method selected. This gives you maximum detail in QuickBooks.

Note that Misc. Income and Expense transaction types are always exported as individual Journal entries, regardless of the choice here.

The File path should be the complete path and filename of the file to be exported. (Whether you export each day individually or all as a single date, it still only generates one file containing all of the transactions.) You can use the Browse button to locate a suitable folder and enter a file name. The file will be a QuickBooks "IIF" file (Import Information File), with an extension of ".iif". Generally you can re-use the same file name every time you export, if you're going to be importing it to QuickBooks immediately afterwards. If you ever needed to re-generate an import file for a given date, you can simply change the dates on the dialog and export a new file.

Exporting the Data

Finally, just click the Export! button to create the export file. It should only take a few seconds, and will report success.

You may also see a warning if there are any charges that weren't mapped to QuickBooks accounts -- this usually indicates that some transaction categories or payment methods were missed, so you need to go back to Setup and check the Transaction Category and Payment Methods mappings. Adding new transaction categories later could also cause this.

When using the Cash Sale export method, note that if there are no transactions for a given day, then no Cash Sale will be exported for that day.

Importing the File to QuickBooks

Once the transactions are exported, open your QuickBooks database and select from the menu: File -> Utilities -> Import... an Import file dialog will open. Just select the file created above and click Open, and the data will be imported. For Cash Sales, you can review the imported data by going to Customers -> Enter Sales Receipts (you may need to use the Previous/Next buttons to locate the correct date.) To review journal entries, go to Reports -> Accountant & Taxes -> Journal, or select the Accounts Receivable account from Lists -> Chart of Accounts.

Repeating an Export (Corrections)

You may need to re-export data once in awhile, especially when initially setting up and testing. However you need to delete all of the previously exported data from QuickBooks to avoid duplication.

If you're exporting as a Cash Sale, this is easy -- just go to Enter Sales Receipts (in QuickBooks), locate the one for the date(s) you need to export again, and delete it -- **Ctrl-D** usually works, but there's also a menu function to delete the sale. If you're exporting as General Journal entries, you'll have to manually delete each of the exported entries manually.

Once that's done, simply repeat the export and import process above.

Taxes Mapping for Auto-taxes

This dialog is used to map each of Campground Master's Transaction Categories for Taxes to a QuickBooks Inventory Item and/or Account. These mappings are used for exporting Tax transactions for auto-tax entries. This may only need to be done if you're using the Cash Sale method and you have auto-tax items set up in QuickBooks. Otherwise, tax categories should be mapped along with the Transaction Category Mapping for other charges. However if you receive an error message when importing to QuickBooks related to tax items being blank, then you need to use tax mappings.

Assuming you used the Import accounts from QuickBooks function first, this may be as simple as picking from lists. If you didn't import the items/accounts from QuickBooks, you can still enter the account names manually, but that is very error-prone.

The process is as follows:

1. Select a tax category to map from the left-hand list (only categories that you have set up in Taxes Setup will be shown.) Note that the Tax Rate will be automatically filled in as defined in Taxes Setup. The Tax Rate field is just for reference, and isn't actually used for calculations in QuickBooks. Don't change it.

2. If this will map to a Sales Tax Item in QuickBooks, select that item from the QuickBooks Sales Tax Item drop-down list. The Account and Description will fill in automatically for that item. You can leave the description or edit it as needed, but don't change the Account, since this has already been assigned to that item in QuickBooks.

QB 2019 and later -- An Item *must* be selected for tax mapping, and it must be appropriately set up as a "Sales Tax Item" in QB. Also make sure you use a different Item for each tax mapped here.

In versions before 2019, taxes are *not* normally mapped to Inventory Items, and in fact QuickBooks from 2005 to 2018 will report an error if you attempt to do so.

3. Select a Vendor from the drop-down list. This is required for taxes, and should be the vendor you have set up as the tax commission or state comptroller (where you pay your sales taxes, for instance).

4. Enter a Description if necessary.

5. If this is an auto-tax item in QuickBooks, check the Is this an auto-tax rate? box. In versions prior to QB 2019, the import will only work if this is checked. **However, as of QB 2019, this must NOT be checked, and having it check will cause an import error!**

6. Click Add Mapping. The details of the mapped category will appear in the bottom list, and the category will be removed from the first list so you know it's mapped already.

Note: If you're using version 10.0 (rev.s) of Campground Master or earlier, you may get a warning that "Is this an auto-tax rate" should be checked. If you're using QuickBooks 2019 or later, you can ignore this warning (click "Yes" to continue).

7. Repeat for all tax categories, then click Save. All of the mappings will be saved and used each time you use the Export function.

Mapping Notes

IMPORTANT: Any of the tax categories you map here should *not* be mapped in Transaction Categories Mapping.

You can map multiple categories to the same Account in QuickBooks if needed. They will generate separate entries to the same item/account. However, they should each have a different Item. If you get the error "You cannot use the same tax item in both the line items and the txn tax.", this is likely due to using the same Item for multiple taxes.

Changing a Mapping

If you need to change a mapping, select it from the bottom list and click Edit or Delete. It will be removed from the bottom list, but it will also be selected automatically in the category/item/account lists, so all you have to do is make any changes and click Add Mapping again.

Transaction Categories Mapping

This dialog is used to map each of Campground Master's Transaction Categories to a QuickBooks Inventory Item and/or Account. These mappings will be used when exporting Charge, Discount, Credit, and possibly Tax transactions as sales totals. It will also be use for the Misc. Income and Expense transaction Journal entries (note that these will not use the Inventory Items, only the Accounts).

Assuming you used the Import accounts from QuickBooks function first, this may be as simple as picking from lists. If you didn't import the items/accounts from QuickBooks, you can still enter the account names manually, but that is very error-prone.

The process is simple:

1. Select a transaction category to map from the left-hand list

2a. If this will map to an inventory item in QuickBooks, select that item from the QuickBooks Inventory Item drop-down list. The Account and Description will fill in automatically for that item. You can leave the description or edit it as needed, but don't change the Account, since this has already been assigned to that item in QuickBooks.

2b. Or, if you're not mapping to an inventory item, select a QuickBooks Account from the next drop-down list, and then enter a Description.

3. If this is an auto-tax item in QuickBooks, check the Taxable? box if it's enabled (if you're using the General Journal Entries method, it's not applicable). For QuickBooks prior to 2019, this is required to be checked in most cases if you're using the "As a Cash Sale" method. **However, as of QB 2019, this must NOT be checked, and will cause an error when importing if checked!**

4. Click Add Mapping. The details of the mapped category will appear in the bottom list, and the category will be removed from the first list so you know it's mapped already.

Note: If you're using version 10.0 (rev.s) of Campground Master or earlier, you may get a warning that "Taxable?" should be checked. If you're using QuickBooks 2019 or later, you can ignore this warning (click "Yes" to continue).

5. Repeat for all categories, then click Save. All of the mappings will be saved and used each time you use the Export function.

Mapping Notes

IMPORTANT: If you are mapping the Tax Categories separately, which is recommended, then **don't** map them here for charges. This will result in an error and/or duplication of values when exporting. (If you receive a tax-item error when importing to QuickBooks, you will need to map the taxes separately.)

All Transaction Categories defined in Campground Master will be shown in the category list, even if they aren't normally used for charges. Thus you don't need to map the categories "Credit", "Discount", etc. unless you might actually use these standard category names for charges, discounts, or credits. If you do want to just clear out the list so you know you're done, you can map them to dummy accounts (no transactions will be exported for them anyway).

You can map multiple categories to the same item/account in QuickBooks if needed. They will generate separate entries to the same item/account.

Changing a Mapping

If you need to change a mapping, select it from the bottom list and click [Edit or Delete](#). It will be removed from the bottom list, but it will also be selected automatically in the category/item/account lists, so all you have to do is make any changes and click [Add Mapping](#) again.

Receipt Payment Methods Mapping

This dialog is used to map each of Campground Master's Payment Methods to a QuickBooks Inventory Item and/or Account, for any receipts (or misc. income) transactions. These mappings will be used when exporting Payment, Refund, and Deposit transactions as sales totals. It will also be use for the Misc. Income transaction Journal entries (note that these will not use the Inventory Items, only the Accounts).

Assuming you used the [Import accounts from QuickBooks](#) function first, this may be as simple as picking from lists. If you didn't import the items/accounts from QuickBooks, you can still enter the account names manually, but that is very error-prone.

The process is as follows:

1. Select a payment method to map from the left-hand list

2a. If this will map to an inventory item in QuickBooks, select that item from the [QuickBooks Inventory Item](#) drop-down list. The Account and Description will fill in automatically for that item. You can leave the description or edit it as needed, but don't change the Account, since this has already been assigned to that item in QuickBooks.

Important: Payment methods are *not* normally mapped to Inventory Items, and in fact QuickBooks 2005 will report an error if you attempt to do so. You should select only a QuickBooks Account (below). This selection is only present in Campground Master for backward compatibility.

2b. Or, if you're not mapping to an inventory item, select a [QuickBooks Account](#) from the next drop-down list, and then enter a [Description](#).

3. Click [Add Mapping](#). The details of the mapped payment method will appear in the bottom list, and it will be removed from the first list so you know it's mapped already.

5. Repeat for all payment methods, then click [Save](#). All of the mappings will be saved and used each time you use the Export function.

Mapping Notes

If you're using the Cash Sale export method, you can opt to leave some of the methods unmapped and let those receipts be the balance of the cash sale. This would typically be the ones like Cash and Check, and the your "Account for Cash Sale" (on the previous dialog) would be "Undeposited Funds". However we recommend against this because it could result in a negative balance (e.g. you have a large cash refund to someone), which cannot be imported to QuickBooks. It's best to map all payment methods.

You can map multiple payment methods to the same account in QuickBooks if needed. They will generate separate entries to the same account. However if you typically put all receipts in the "Undeposited Funds" account, we suggest creating Items in QuickBooks to sub-section the Undeposited Funds for separating cash, checks, and credit cards. This is because the true payment method in the cash sale cannot be set individually for each receipt type as they are all combined into one cash sale. To make a separate payment item, create a New Item in QuickBooks, set it to a Payment type, enter an appropriate Item name, Description and Payment Method (e.g. "Check"), and group it with other undeposited funds. Now when you map the Receipt Payment

Methods to the appropriate items, they will all go into Undeposited Funds as expected but will show as separate items when making deposits.

Changing a Mapping

If you need to change a mapping, select it from the bottom list and click Edit or Delete. It will be removed from the bottom list, but it will also be selected automatically in the lists above, so all you have to do is make any changes and click Add Mapping again.

Expense Payment Methods Mapping

This dialog is used to map each of Campground Master's Payment Methods to a QuickBooks Account, specifically for Expense transaction Journal entries. If you never enter Expense transactions in Campground Master, these mappings aren't needed.

Assuming you used the Import accounts from QuickBooks function first, this may be as simple as picking from lists. If you didn't import the accounts from QuickBooks, you can still enter the account names manually, but that is very error-prone.

Remember that you're mapping payment methods for expenses here, so this is money going out, not money received. Thus a credit card payment method should be mapped to a credit card account, not the merchant/bank account that receives your credit card sales.

The process is as follows:

1. Select a payment method to map from the left-hand list
2. Select a QuickBooks Account from the drop-down list, and then enter a Description.
3. Click Add Mapping. The details of the mapped payment method will appear in the bottom list, and it will be removed from the first list so you know it's mapped already.
5. Repeat for all payment methods that you might use for Expense transactions, then click Save. All of the mappings will be saved and used each time you use the Export function.

Mapping Notes

You don't need to map all payment types, only the ones that you might use when paying for expenses.

You can map multiple payment methods to the same item/account in QuickBooks if needed. They will generate separate entries to the same item/account.

If you need to change a mapping, select it from the bottom list and click Edit or Delete. It will be removed from the bottom list, but it will also be selected automatically in the lists above, so all you have to do is make any changes and click Add Mapping again.

11 Online Reservations

Overview

Campground Master supports Online Reservations in a few different ways, depending on your needs. You can use one part of it or any combination of parts:

- Integrate in a real-time 2-way automatic mode with Leisure Interactive's online service, *Hercules*. Reservations are automatically imported, and availability is automatically uploaded, preventing any conflicts with online reservations.
- Retrieve reservation information from *Hercules* in manual mode (e.g. if your online connectivity is limited).
- Retrieve and extract reservation data from formatted E-mails (like form submissions from your web site, or E-mail notifications from other online services).
- Create "vacancy grid" web pages with availability data and upload them to your own web site.
- Retrieve "iCal" files and extract the information (e.g. from online services like AirBnB)
- Export "iCal" files to upload for services like AirBnB

General Guidelines for Taking Online Reservations

While Campground Master is not an online system in itself, it can integrate with 3rd-party online reservation services like *Hercules* in real time just as though it's a combined system, or it can assist in taking reservations through your own web site. Naturally a high-speed Internet connection is recommended for this, especially if you get more than a few reservations per day.

Avoiding Conflicts Between Online and Offline (Local) Reservations

Using the *Hercules 2-way integration*, conflicts are automatically avoided as long as you have internet connectivity.

If you need to use one of the other options, accepting online reservations is only fool-proof if you set aside certain sites to be used *only* for online requests, since the person online can't see your local system at exactly the same time as you. Without this separation of sites, you could potentially be making a reservation on the same site and for the same day as someone online, resulting in a conflict. Campground Master lets you designate which sites are to be shown as available online (assuming you use one the option to upload availability data to your own web site).

If separation of sites isn't practical, you can also minimize potential conflicts by taking requests only for a certain type of site instead of taking requests for a specific site number. The customer would select the type of site, and you would select an appropriate site for them as you process the request locally. You can also combine this with limiting the number of sites available online. For instance if you have 40 cabins and 50 tent sites, you might designate only 20 cabins and 20 tent sites for online availability

You can also specify a number of "online release days" as a buffer -- for instance, you may specify that online reservations can only be made for dates at least 3 days in the future (or any number of days you think is appropriate). This allows you to handle short-term walk-in customers without worrying about conflicting with online reservation requests.

Handling the Online Reservations

Using the *Hercules 2-way integration*, online reservations can either be automatically imported to Campground Master or you can manually process them as they are received. Reservations imported automatically can be reviewed easily through the function Reservations / View Recent Online Reservations, and then edited if necessary.

If you use a different form of online integration, manual processing is required. Manual processing requires an operator to view the reservation request and make sure everything is in order before saving it. While this isn't as convenient as a fully-online system, it's necessary to eliminate "junk" requests from the Internet, duplicate customers, missing information and other problems associated with manual systems.

When manually processing online requests, the operator can assign a site if necessary, send a confirmation E-mail to the customer, and save the reservation into Campground Master. Assuming that most of the information is filled out properly by the customer on the web site, this is a fairly quick and easy process and eliminates the need for customer information to be typed in manually.

Hercules (2-way integration)

Overview

Campground Master's 2-way real-time integration with Hercules offers the most robust online integration available of any system. It offers the best of both worlds -- a first class front office system that you have full control over, coupled with an industry leading online reservation system that seamlessly melds into your web site.

"2-way" means that reservation and availability information flows both ways -- reservations made online are imported to Campground Master without any re-typing necessary, and reservations made locally (as well as other site availability changes) are uploaded to the online system. This means that both systems will be in sync without any effort on your part.

"Real-time" means that the synchronization happens continuously and automatically. Most importantly, it means that you can offer your entire inventory of sites to online reservations without worrying about conflicts between online and local reservations. You may never have to go online to adjust your site availability, since it's all done automatically. You can even specify certain dates that each site should not be available online, e.g. for special events you know will be full well in advance, all within Campground Master.

Getting Signed Up

Hercules is an online reservation system offered by Leisure Interactive (formerly Friend Communications). Before you can use Campground Master to integrate with their online system, you need to sign up for their service and get it set up. For more information, visit our web site: <http://campgroundmaster.com/online.html>.

Site Locking

No matter how "fast" a real-time system is, it can't avoid conflicts without "locking" sites before using them, to ensure that the other side can't start a reservation on the same site you're working on. This is accomplished with Hercules the same way it's done with the Campground Master local networking functionality, with one exception -- because the response from the internet may take a little longer, Campground Master doesn't have to wait for the response before letting you continue your work. Instead, it will check to see what the lock response was when you're at a point where any potential conflict needs to be avoided (e.g. saving the new reservation). If there is a potential conflict with someone making a reservation online (typically a rare occurrence), then it will warn you (and/or prevent continuing, depending on the operator's access level).

Likewise, whenever a site is being used locally for a reservation, Hercules will know about it and will prevent anyone from selecting that site for an online reservation.

Automatic vs Manual

Normally the fully automatic mode should be used, since this is the only way to prevent conflicts 100% of the time. However if you're having trouble with internet connectivity then there is the option to fall back into manual mode for uploading and/or downloading. Site locking can also be skipped, and uploading and downloading reservation changes will not take place until you request it. You can get them synchronized any time, through Reservations / Retrieve Online Reservations, but keep in mind that conflicts could arise during the time that the data has not been synchronized.

Hercules 2-way Setup

Overview & Check list

There are several things that need to be set up before the 2-way integration is ready to use. For the most part it's easily done, and the checklist below along with detailed information on each part should guide you through it pretty quickly.

Here's a summary and checklist of the setup procedure. See the following sections for details on each step:

Preparation:

- Get a Hercules account prepared (through Leisure Interactive, see <http://www.leisureholding.com/>), and make sure they set it up for the "2-way" interface with Campground Master. Once you have the account set up, you will need your Customer # (also known as your customer "Record #") and have Hercules set up a Password for the 2-way interface (this is different than the web site login). There are also some other things you will need to know for configuration later, such as the Space Numbers (which ideally you will have them set up to match your site Abbreviations), Adder ID's, and Discount ID's.
- If you want to use a separate Payment Method for the deposit made online, add that through Maintenance / Pick Lists / Payment Methods.
- If you want to use a separate Reservation Type for the reservations made online, add that through Maintenance / Pick Lists / Reservation Types. Typically this isn't necessary (you can just use the default "Normal" type), but it's an option if you want the online reservations to have a separate type for reporting, rates calculation, or other reasons. If necessary, you can define 2 types for online reservations -- one for reservations longer than a certain number of days (e.g. Weekly or Monthly), and one for reservations shorter than that. (Actually you can have any number of types, but any other special cases would need manual adjustment after the reservation is imported.)
- If you want or need to enable or set up Site Attribute fields for the various Amp Service values, you can do that (see Data Field Definitions). Typically this would just be whatever you're already using, most often just an option for 50A, so it's not likely that you would need to change this. These will be mapped to Hercules values in the next steps.
- If you want to add or modify Rig Types to correspond with the Unit Types available through Hercules, do that through Maintenance / Pick Lists / Rig Types. Most often you will just use the values you already have set up there already, but in some cases you might want to add some that Hercules offers that are different than the default options in Campground Master. These will be mapped to Hercules values in the next steps.
- If you need special Discount types for discounts offered through Hercules, set those up through Maintenance / Pick Lists / Discounts. This is not usually necessary, since the discounts used online can be mapped to your existing discounts in the following steps.

Configuration:

- Configure the various options (see Maintenance / Online Reservations / Hercules / Hercules Setup):
 - Operation options -- update mode, timing, etc. (But don't "Enable" it yet!)
 - Reservation creation options
 - Parsing options, including:
 - Site Data Fields (mapping your Sites to Hercules "Space numbers")
 - Amps Service values mapping
 - Unit Types values mapping
 - Adders Mapping
 - Discounts Mapping
 - Availability settings
 - Connection settings (Hercules account user name and password, etc.)
- Set up Access Levels, for whether to allow the operators to continue when there are warnings (see Maintenance / Park Setup / Access Levels). The access levels for the Hercules 2-way are show in the Access Level list with the prefix "Hercules Online Res. - Allow continuing....".
- Set the Alerts Options, for when handling user alerts such as new reservations received or synchronization errors (see View / Alerts / Alerts Options). There are also several Access Levels associated with Alerts (see Access Levels in the step above). The Alerts access level settings are just below the Hercules access levels in the list.
- If you were using the 1-way Friend integration before, disable it (see Maintenance / Online Reservations / Other Online Interfaces / Connections & Options / Reservation Friend, and uncheck the "Enable" box).

Starting Communications

- When ready to "go live", Enable the Hercules functionality to begin communications (see Maintenance / Online Reservations / Hercules / Hercules Setup).
- Also note that you need to make sure Campground Master is not being blocked from the Internet by any security software or firewall. You may see a warning from Windows Firewall, for instance, asking whether Campground Master should be blocked -- make sure you always "Allow", "Unblock" or "Approve" Campground Master. If you don't see this message, it might be that Campground Master had been blocked before. If you get an error indicating that it can't communicate with Hercules, check your firewall and security settings.
- Most likely it will initiate a full synchronization upload right away, followed by a download if there are already reservations online to be downloaded. You won't see any of this happening, unless there is a problem or something is downloaded that needs your attention. Then you may see an Alert that new reservations have been automatically imported, and/or an Alert that reservations could not be automatically processed and need to be manually processed. See the Initial Synchronization section for more details.
- From here on it should be communicating and in sync. If you log into the Hercules web interface and refresh the grid, you should see an "External reservation" for each of your Campground Master reservations (or a customer name if it was initially created online). You may also see a "Maintenance Hold" on sites that you've designated as Unavailable. If you don't see this within a few minutes, there may be a communication problem and you need to contact support. Be sure to read through the Operations sections for more information.

Conversion from 1-way integration

If you have already been using the 1-way integration with Reservation Friend, then the applicable part of your setup will be transferred automatically.

The same Site field for the Hercules Space Number of each site is used, so the ones you have filled in will still apply. However, since you can put your entire site inventory online with the 2-way interface, you should **fill in the Hercules Space Numbers for the rest of your sites** (and don't forget to **enable the sites for online reservations on Hercules**, through their Hercules web interface).

Also, a few of the Reservation options, such as the deposit description, operator, and Payment Method will be transferred from your 1-way settings.

If you've set up special Parsing Rules for Adders, such as # adults, # children, etc., those will no longer be used. You will need to map those adders through the Adders Mapping function (which is actually much easier than the parsing rules).

Other settings from the 1-way interface will no longer be used, such as the parsing rules and the E-mail connection options. The 2-way interface no longer uses E-mail, so once you've converted then you don't need that POP3 mail box any more. Also, the Site field for the online release days is no longer used, since it's not necessary to prevent local reservations for "online" sites for certain days in the future.

You should also disable the 1-way interface once you're using the 2-way integration. While it shouldn't interfere, assuming you don't actually retrieve the reservations with that method any more, disabling the 1-way interface will prevent accidentally downloading reservations the old way. To disable the 1-way, go to Maintenance / Online Reservations / Other Online Interfaces / Connections & Options / Reservation Friend, and uncheck the "Enabled" box.

Data Fields

The data fields used for the Hercules 2-way integration will be automatically enabled. For reference, these are the fields involved:

The Reservations data field "**Resv_Online_Request_ID**" -- this is used to store a unique identifier for each online request, to aid in synchronization with the online data.

The Reservations data field "**Resv_Online_Request_Raw_Text**" -- this holds the raw text of the online request. While this isn't technically required, we recommend enabling this just in case there is any question about what came from the online system (especially for troubleshooting). You can view the Online request text through Reservation Details.

The Site data field "**Site_Online_Friend_ID**" -- this will contain the "space number" as it's configured on Hercules.

The Site data field "**Site_Online_Friend_Unavailable**" -- this can be set to a list of date ranges that the site should be unavailable for online bookings.

For details on configuring the site fields, see the Site Data Fields section.

Hercules Setup

Most setup functions for Hercules 2-way integration are accessed through Maintenance / Online Reservations / Hercules / Hercules Setup. This one dialog (with multiple tabs and some sub-functions) covers just about everything needed for configuring the 2-way integration.

Note that communications with Hercules is suspended while this dialog is open (in case any critical settings are changed), so be sure to only go into this during times when there are no other local operations (e.g. on other workstations in a networked environment).

Hercules Setup - Operation

This is accessed through Maintenance / Online Reservations / Hercules / Hercules Setup, Operations tab. These options control the overall operation of the 2-way integration.

If setting up for the first time, we recommend that you leave all of the values on this tab in their default state, and do **not** check the "Enable" box until all other initial setup has been completed. For reference, the recommended values are listed below with their descriptions, but if you're doing the initial setup then you can **skip this section** until you're ready to turn on communications.

Enable Hercules functionality -- naturally this turns the 2-way communications on or off. Note that if this is ever disabled, even for a short time, then a full synchronization with Hercules will be initiated when it's re-enabled.

Workstation ID to poll from -- (a.k.a.. the "Hercules master" workstation) -- If you use Campground Master on a single computer, this should be set to 0. If you have the Networking option, then we recommend that this be set to the Master workstation's ID (see Networking Setup if you're not sure what that is). However it can be set to another workstation if needed, for instance if internet connectivity is not available on the Master. While it does not technically affect operations of the 2-way integration, certain functions can only be done on the "Hercules master", and of course there are added communications delays involved when it's not set to the network Master.

Never poll from this computer, regardless of it workstation ID -- Unlike the other settings, this is set in the INI file on the computer, not in the database file. That means it stays for this computer set even if you restore from a database backup. So this allows you to disable the online synchronization for 'offline' computers, e.g. computers separate from the live system used for training, or off-site computers used for backup or reporting purposes.

Incoming reservation handling -- The recommended setting is "Fully automatic processing". In this mode, Hercules is periodically polled for new reservations, and any new ones are automatically processed and added to Campground Master. If you need a little more control, you can set it to "Automatically check for requests but require manual processing". In that mode you would be notified of new ones available to process -- just be sure to process them immediately when notified to avoid conflicts with local reservations. There is also a "Manual request only" mode, which is primarily used for testing purposes. In this mode, no automatic polling is done, and you have to request reservation downloads manually to find out if any are available.

Alert when new reservations are auto-processed -- While the "Fully automatic" mode imports the online reservations with no operator effort, we recommend that you enable this option so that you can see when this happens. This also gives you a change to review the reservation. See the Automatic Modes section for more details.

Outgoing reservation handling -- The recommended setting is "Fully automatic availability upload". In this mode, all local changes are automatically uploaded to Hercules so that its availability information is updated without any user action required. If you set this to "Manual upload only", then you must initiate the upload each time you want it updated online.

Locks/Temp Holds/Update status checking -- The recommended setting is "Do locks & synchronization, and wait/warn if issues before completion of operation". This makes the request but does not make the operator wait for a response -- e.g. they can continue to work on the reservation without delay. Once they are ready to save the reservation, they will be notified if a potential conflict might occur due to an online reservation in progress for the same site. The other options are:

- Skip all site locks & synchronization -- This of course defeats the purpose of real-time 2-way integration, and should only be used for testing or other extreme conditions.
- Initiate locks & synchronization, but don't wait -- This tells Hercules what's going on, but ignores any response that might suggest a conflict. Basically this gives Hercules a chance to lock out sites you're working on locally, but there is still a chance that an online reservation creates a conflict (e.g. if it's started online but not completed & downloaded before you use the site locally). This should only be used if you're having connection problems that are causing severe delays in responses.
- Do locks & synchronization, and wait/warn if issues before starting the operation -- This could be used if you don't mind waiting for a response before continuing a reservation, for instance. Naturally this should only be used if the response time is fast enough for your comfort. The advantage is that you avoid the possible annoyance of finding out only at the end of making a reservation that the site isn't available online. This is also a viable option if the majority of your reservations are made online at a rapid pace, such that a local reservation is frequently denied due to an online site lock.

Update frequency -- If either Incoming or Outgoing modes are set to Automatic, this determines how often Campground Master will initiate an automatic update (up and/or down). The default and recommended setting for this is 1800 seconds (30 minutes). This may seem like a long time, but unless you get dozens of online reservations each day then it's probably sufficient. Keep in mind that regardless of this frequency setting, conflicts are still prevented by the site locking. Also note that any time a local operation is initiated, any waiting online reservations are downloaded anyway, and any local changes are usually uploaded immediately -- so this update frequency is mostly applicable to times when Campground Master is idle.

Wait for idle time before attempting update -- This is usually not necessary, as the update takes little time, so the recommended setting is to not check this option. Since downloads happen automatically when starting an operation anyway, this would only be an issue if for instance a major synchronization is needed. If you do enable this, the recommended time is 60 seconds.

Hercules Setup - Reservations

This is accessed through Maintenance / Online Reservations / Hercules / Hercules Setup, Reservations tab. These are various options related to how online reservations are converted to Campground Master reservations, plus a couple options that affect the online site availability.

Default status to use for imported reservations -- You can choose whether the online reservations are created as Pending, Confirmed, or Guaranteed. Since payment is taken online for the reservations, the Guaranteed status is recommended.

Confirmation # format -- This allows you to specify the confirmation number formatting in Campground Master. You can keep this the same as the Hercules confirmation/order number by entering <O> here (a special tag for inserting the Online Order ID). Or you can use other formatting options to keep it similar to other reservations in Campground Master, or perhaps add a prefix so you know it's a Hercules order -- such as "RF-<O>" so it looks like RF123456. For full details on formatting options, see the Confirmation # formatting under Maintenance / Program Options / Format Options. The only difference here is the availability of the <O> tag as mentioned above.

Reservation Type for online reservations -- Select the reservation type to use for reservations made on Hercules. This would typically be "Normal", or whatever you've named your normal reservation type (see

Maintenance / Pick Lists / Reservation Types). You could add a special type if you like, but remember that a new type would also need to be configured in your Rates setup so the correct rates apply.

If reservation is (X) nights or longer, use the type -- This option allows you to have a 2nd reservation type automatically applied if the reservation is longer than a certain number of nights. This might be used for instance if you use a custom "Weekly" type for any reservation 7 days or longer. While this could be used for monthlies, it might not be as easy to configure since each month is a different length.

Operator name to use -- You can enter any text you like for the operator name to be shown for the reservation and also any of the transactions automatically added for the reservation. If this is left blank, the transaction and reservation will be recorded with the operator logged in at the time the reservation is processed -- which is not recommended, especially if automatic processing is enabled.

Settings to use for online deposit transactions:

Online reservations will import with a Deposit transaction, showing the payment made online. Here you can specify the description and Payment Method to be used for the deposit.

Description -- You can enter the transaction description to show (e.g. on receipts) for the deposit. If this is left blank, it will default to the payment method name.

Payment Method -- You should set up a special Payment Method for online reservations and select it here, so reports and QuickBooks exporting, if used, will keep the online payments in a separate account appropriately. If you first started using Campground Master at version 5.0 or later, then there is already an "Online" payment method defined that you can select. Otherwise, you can add your own to use here (see Maintenance / Pick Lists / Payment Methods). **Don't leave this setting with the default payment method selected (e.g. "Cash")!**

Hercules Setup - Parsing

This is accessed through Maintenance / Online Reservations / Hercules / Hercules Setup, Parsing tab. These are more options related to how reservations are converted from Hercules, and more specifically how the online data fields are converted, or "Parsed", into Campground Master terms.

Ignore country name if matches one of these -- You can enter one or more country names or abbreviations, and if the online data matches one of them then the Country field in the Campground Master customer will be left blank. The recommended setting, for U.S. customers, is "USA,U.S.A.". Note that case is ignored, and multiple entries are separated by commas. If you're in Canada, then you may want to change it to "Canada".

The buttons below open a further configuration dialog, and are thus covered in the following separate sections:

[Site Data Fields](#)

[Amp Service values mapping](#)

[Unit Types mapping](#)

[Adders mapping](#)

[Discounts mapping](#)

Memo Transactions for Adders, Discounts, etc.

The imported online reservation data contains various details about the reservation's charges (fees). While the only "real" transaction added in Campground Master is the Deposit amount, you can also have it add the various details as Memo transactions for your reference. The recommended setting is to leave these all enabled, at least until you're comfortable that the correct amounts are being charged online.

Ideally you already have Campground Master set up to automatically calculate the charges (Auto-Rates), which will be added automatically when the reservation is created or checked in. Adding these online amount details as memos can serve as a verification that the amounts charged online match your rates, or if you're not using auto-rates, they will serve as a guide to what real Charges should be added for the reservation. Once you have confirmed that everything is correct, you may prefer to delete these memo transactions from the reservation. (Either way, the memos will not appear on the customer's receipt.)

Adding Memos for the Adders and Discounts is covered in the Adders & Discounts mapping functions. There are a few other settings here for adding Memos for the other values:

Add order amount as a memo transaction -- This will show the base rent amount charged for the site (total, not per day).

Add order taxes as memo transactions -- If one or more taxes were charged, these will be shown.

Add order total as a memo transaction -- a Total is also included, which ideally should always match the Deposit and of course the sum of all other charges (Amount, Adders, Discount, and Taxes). However it may be handy to show that as a memo just for verification purposes.

Expression to execute after adding reservation -- To ensure that all special needs can be accommodated, we allow you to create a custom processing script that's executed after the reservation is added. This script will have access to the raw online data through the field Resv:Resv_Online_Request_Raw_Text (provided that you have not disabled that reservation field), and could be used to make any changes to the reservation needed. Naturally this gets into "programming", and falls under Advanced Customizations. For details on what this expression needs to be, see the Expressions details in the Advanced Customizations section.

Site Data Fields

This is accessed through Maintenance / Online Reservations / Hercules / Hercules Setup, Parsing tab, and click the Site Data Fields button. The fields are listed in a grid format, like in Raw Data tables, because it's very helpful to edit them as a group and see the overall view.

Only the online data fields that are enabled will be shown -- so if you just see an empty list, you haven't enabled any of the expected fields (through Maintenance / Data Field Definitions / Sites). Note that if you used other online interfaces in the past, it might show more than the two fields described below. Those "extra" fields can be ignored.

To change fields values, just edit them directly in the grid. Some values will be drop-down lists, depending on the type of field. You can also use copy/paste functions to copy a value to one or more fields.

WARNING -- any changes made here are instant and non-reversible, just like raw data tables. There is no Cancel or Undo function here.

Hercules Space Number -- Set this to the space number for the site as configured on Hercules, which can be different than the Site Name for the sites in Campground Master. For instance, the name might be "RV Site 1", but on Hercules it might be shown as "RV1" or just "1". Note that this only has to be entered for the sites you make available for reservations on Hercules. Leave it blank for sites not listed on Hercules, or if you don't have it enabled for "Online" on Hercules. Of course with the 2-way interface, you can enable your entire site inventory online without fear of conflicts.

Important: If a Hercules space number is entered here that does not match a space configured as an online site in Hercules, it will be unable to lock the site on Hercules and thus error messages will occur when doing local operations. It could also mean that true availability is not being synchronized to Hercules. Therefore it is very important that these match the Hercules data.

Copy Site Abbr/Name of ALL sites to Hercules Num -- For initial setup convenience there are buttons allowing you to copy either the Site Abbr. or Site Name of all sites to the Hercules Space Number. Assuming that the spaces on Hercules have been set up according to either the Abbr or Name field in Campground Master, this will make the setup a 1-click operation.

Hercules Unavailable Dates -- This allows you to block individual sites from online reservations on certain dates. This might be a season, special event, or some other reason that you don't want any online reservations on the site. (While this field affects individual sites, there is also a global setting that allows you to set unavailable dates for all sites at once -- see Hercules Setup / Reservations.)

Take care when using this setting, as entering it incorrectly could result in the site being blocked online for all dates, or not blocked on the dates you expect. After changing this setting and allowing the synchronization to occur, we recommend that you verify the dates through your account on Hercules (through their web interface). You can enter single dates, a date range, or any number of date ranges. You can also enter dates or ranges without a year, so it repeats each year.

Note that any dates set as "Unavailable" in Campground Master using the site's Season Dates Applicable or Special Dates Unavailable Field will automatically be unavailable online as well -- so there is no need to duplicate those dates here. The site will be unavailable online for any of those dates plus any dates set in this field.

For more information on the format of this setting, see the details for setting the Season Dates under Maintenance Functions / Park Setup Functions / Edit Site Details. You can use Copy/Paste (Ctrl-C / Ctrl-V) to copy dates to multiple sites easily, just like you would in Excel.

Amp Service Values Mapping

This is accessed through Maintenance / Online Reservations / Hercules / Hercules Setup, Parsing tab, and click the Amp Service values mapping button.

The reservation data from Hercules includes a single "Amp Service" value, with several different possible values (shown in a list here under "Hercules ID"). However in Campground Master you have a different type of field or multiple fields that need to be set accordingly. This mapping function is used as a parsing rule to determine which Campground Master field to set based on the Amp Service value from Hercules.

Most often, this will simply be a "50A" preference field for the reservation. In fact, if you have the 50A attribute/preference field enabled for Reservations, the values including 50A will be automatically mapped for you. So you would only need to modify or add mappings if the values for 15, 20, 30, or 100 amps mean something for your setup, or if the standard 50A field is not used in your setup to mean that they want 50A service.

The mapping process is as follows:

1. Select (highlight) a Hercules ID to map in the left-hand list.
2. Select a field from the Reservation Field drop-down list.
3. Select the Value to set field to in the next drop-down list, or enter a value. For preference fields like 50A that have pre-defined values (e.g. "Must Have" or "Must Not Have"), you should select from the drop-down list. If the field does not have designated values, simply type the desired value.
4. Click Add Mapping. The details of the mapped value will appear in the bottom list.
5. Repeat for all values that require fields to be set, then click Save.

Note that there is no need to map values if you don't need a field set for them in Campground Master. For instance if the only field of interest is 50A, then you only need to set the mapping for the Hercules ID's with 50 in them (and they would all be mapped to the 50A field, value set to "Must Have").

Mapping Notes

You can map multiple Hercules ID's to the same Reservation Field if needed.

If you need to change a mapping, select it from the bottom list and click Delete/Edit. It will be removed from the bottom list, but it will also be selected automatically in the lists above, so all you have to do is make any changes needed and click Add Mapping again.

Unit Types Values Mapping

This is accessed through Maintenance / Online Reservations / Hercules / Hercules Setup, Parsing tab, and click the [Unit Types values mapping](#) button.

The reservation data from Hercules includes a "Unit Type" value, with several different possible values (shown in a list here under "Hercules ID"). In Campground Master you have a "Rig type" field that needs to be set accordingly, but your values might be different. The possible Rig type values in Campground Master are defined in the Rig Types Pick List, which you can modify if desired (see Maintenance / Pick Lists / Rig Types).

However it's not necessary to create perfectly-matching values in the pick list, since you can use this mapping function to convert the Hercules values to Campground Master values.

If you still have any of the default Rig Types in your pick list, some of those values which match up with Unit Types will be automatically mapped for you. So you may see several values already mapped when you go into this function. You only need to see if the other Unit Types need to be mapped to your Rig Types.

The mapping process is as follows:

1. Select (highlight) a Hercules ID to map in the left-hand list. (The numeric value is shown next to the name only for reference, and is not important.)
2. Select the corresponding type from the [Rig Type Value](#) drop-down list.
3. Click [Add Mapping](#). The details of the mapped value will appear in the bottom list.
4. Repeat for all ID's/values that might be selected on Hercules, then click [Save](#).

Note that there is no need to map Unit Types if they do not apply or would never be used on Hercules. For instance if you don't have a marina, there's no need to map the "Sailboat" value.

Mapping Notes

You can map multiple Hercules ID's to the same Rig Type if needed.

If you need to change a mapping, select it from the bottom list and click Delete/Edit. It will be removed from the bottom list, but it will also be selected automatically in the lists above, so all you have to do is make any changes needed and click Add Mapping again.

Adders Mapping

This is accessed through Maintenance / Online Reservations / Hercules / Hercules Setup, Parsing tab, and click the [Adders mapping](#) button.

Hercules uses "Adders" for extra add-on fees and values like # adults, # children, # pets, etc. This function is used to convert their Adders into field values and/or transactions in Campground Master. For instance, the # Adults adder needs to be mapped into the # Adults field for the reservation.

The key here is that you need to know the "Adder ID" from Hercules for each adder used for your online reservations setup. These vary by account, so you need to find out what your Adder ID's are from Hercules.

The process is as follows:

1. Enter a [Hercules Adder ID](#) to map.
2. Enter a Description (optional -- this is for your own reference).
3. Select the corresponding [Reservation Field](#) in the drop-down list. Use the "(none)" option if no field needs to be set, but you want to specify a transaction to be added.
4. If a field was selected, select the [Value to set field to](#) in the next drop-down list, or enter a value. For preference fields like 50A that have pre-defined values (e.g. "Must Have" or "Must Not Have"), you should select from the drop-down list. If the field is a numeric or text field, you can either enter a fixed value or choose an option from the list to copy the Qty as-is from the Hercules adder, or to use the Qty with an adjustment.
5. If "Use Qty from adder, with adjustment" was selected in the step above, then enter an [Adjust qty by](#) amount. This would be used for instance if you have an adder for "# vehicles" on Hercules, but in Campground Master it's used for "Extra vehicles", meaning that one vehicle is allowed and Extra vehicles only needs to be set to the amount more than one. Thus you would enter a -1 (negative 1) in the [Adjust qty by](#) field, so it sets "Extra Vehicles" to one less than the "# Vehicles" adder qty.
6. If the field selected in step 4 was a text field, you will have the option to [Append to the existing text in the field](#). Check this option if you don't want to overwrite other data in the field, such as Notes.
7. If applicable, check the [Only use if Qty is greater than](#) option and enter the amount. This allows you to have it skip the field setting if the adder qty won't matter. For instance in the Extra Vehicles example above, you would enable set this option and set it to 1, so that it only applies if the "# Vehicles" Adder qty is more than 1.
8. If you want a memo transaction added for the adder, select the transaction type in the [Add a Transaction for the adder as](#) list. You can choose a normal Memo or a Printable Memo (which would appear on the customer's receipt). Keep in mind that you will often be adding Charge transactions as well, for the real charges, so the Memo transactions are not required -- but they can be handy for verification since the Memo can show the amount charged on Hercules for the adder.
9. If adding a transaction, you can enter a [Transaction description](#). If this is left blank, a default description will be used that includes the adder ID, description, qty and amount from Hercules. Since these are often more lengthy than desired, you can enter a shorter description here. You can use "place holders" in the description that will be replaced by adder information. For instance, entering "Adults:%Q% = %A%" here would result in a description like "Adults:3 = \$6.00".
10. Click [Add Mapping](#). The details of the mapped value will appear in the bottom list.
11. Repeat for all adder ID's that might be used on Hercules, then click [Save](#).

Mapping Notes

If an Adder is received from Hercules that is not mapped, it will be added to the reservation as a generic Memo transaction. This allows you to see the information in the Reservation, including the Adder ID, so you can set a field if needed and go back and correct the mappings for next time.

If you need to change a mapping, select it from the bottom list and click Delete/Edit. It will be removed from the bottom list, but it will also be selected automatically in the fields above, so all you have to do is make any changes needed and click Add Mapping again.

Multiple mappings may be created for the same Hercules Adder ID, for instance if you need to set multiple fields for it.

Discounts Mapping

This is accessed through Maintenance / Online Reservations / Hercules / Hercules Setup, Parsing tab, and click the [Discounts mapping](#) button.

Hercules can apply "Discounts" similar to the way Campground Master does, for Good Sam, AAA, etc. This function is used to convert their Discount ID's into field values and/or transactions in Campground Master.

As with Adders, the key is that you need to know the "Discount ID" from Hercules for each discount used. These vary by account, so you need to find out what your Discount ID's are from Hercules.

The procedure for setting up Discount mapping is almost identical to the Adders mapping, so it's not detailed again here. There is just one primary difference in the Discounts mapping -- instead of the focus being on a quantity, as in adders for # Adults for instance, Discounts are typically either present (if it applies) or not present.

Therefore, instead of setting a field quantity, generally you will just set the Discount field to the appropriate value for each Hercules discount ID -- e.g. for the Hercules ID for a Good Sam discount, set the Reservation Field "Discount" to the value "Good Sam". The important thing is to make sure you're entering the Value exactly as you have it in the Pick Lists for Discounts -- including the precise capitalization.

Hercules Setup - Availability

This is accessed through Maintenance / Online Reservations / Hercules / Hercules Setup, Availability tab. These options affect the availability of sites for online reservations.

Owner reservations make the site unavailable for online reservations -- If you use the "Owner" reservation type, then this setting depends on the way you use Owners in Campground Master. If Owner reservations are on sites truly owned by someone and available for sub-letting to overnight campers, etc. when the owner is not present, then this option should not be checked. Thus it's available online as long as there isn't another reservation on top of it (and this also requires you to make normal or Free Stay reservations on the site when the owner is actually present, to avoid double booking). However if you use the Owner type for other situations, such as a Seasonal, where the site should not be occupied by anyone but that one person, then you should check this option to keep it unavailable for online reservations.

Special dates unavailable for online reservations -- This allows you to block all sites from online reservations on certain dates. This might be a season, special event, or some other reason that you don't want any online reservations on any site. (While this setting affects all sites, there is also a Site field that allows you to set unavailable dates for individual sites.) Take care when using this setting, as entering it incorrectly could result in all sites being blocked online for all dates, or not blocked on the dates you expect. After changing this setting and allowing the synchronization to occur, we recommend that you verify the dates through your account on Hercules (through their web interface). You can enter single dates, a date range, or

any number of date ranges. You can also enter dates or ranges without a year, so it repeats each year. For more information on the format of this setting, see the details for setting the Season Dates under Maintenance Functions / Park Setup Functions / Edit Site Details.

Max future days to upload for "unavailable" status -- The recommended setting is 1096 days (3 years). While someone could technically make a reservation online for a date more than 3 years in advance, it's not likely. This setting determines how far in the future that "season" or "unavailable" dates for sites (or the unavailable dates setting above) affect the online availability, particularly if you use date ranges without the year included (so they apply to every year in the future, forever). The larger you make this number, the longer a full synchronization upload could take -- otherwise it does not affect normal operations.

Hercules Setup - Connection

This is accessed through Maintenance / Online Reservations / Hercules / Hercules Setup, Connections tab. These settings are critical for the connection itself. Once these are set, there is usually no reason to ever change them.

Automatically connect to the Internet each time -- If your internet connection is high-speed (always-on), this setting won't matter -- but we recommend that this option be checked anyway. However if you use a dial-up internet service, you can select this option to connect automatically when it needs to communicate. Of course if all you have is dial-up, the 2-way interface is probably not going to work for you anyway.

Customer # and Password -- You will need to enter the appropriate settings for connecting with your account on Hercules. Contact Leisure Interactive to get the proper settings -- keep in mind that these are **not** the same as the Username and Password that you use to log in to the online interface. Be sure to ask for the 2-way interface customer number (they also call it the Record # and it's usually a 5-digit number) and have Leisure Interactive set up a 2-way interface password for you.

Download & Upload host/file/port -- These entries default to the proper settings to use, as of the time of this writing. **Be careful not to modify them!** Just in case you need to fix them, here are the correct settings (again, accurate as of the time of this writing, but they may change if Hercules changes its servers):

Download host:	https://hercules.reservationfriend.com	Port: 443
Download file:	/Sync.aspx	
Upload host:	https://hercules.reservationfriend.com	Port: 443
Upload file:	/Sync.aspx	

Local Working Directory -- This is where it will save the downloaded requests locally, for temporary processing. Other temporary files may also be placed there, for instance the availability data to be uploaded. The recommended setting is to leave this blank, which means it will use the same folder as the Campground Master database. If you prefer to put it somewhere else, enter the entire path name here. However be very careful that the path actually exists and has the necessary permissions for Campground Master to manipulate files there.

Hercules Setup - Diagnostics

This is accessed through Maintenance / Online Reservations / Hercules / Hercules Setup, Diagnostics tab. While mostly applicable for diagnostic issues, there are some timing settings here. These settings should be left at their default values unless you're having problems and our support recommends changes to them. Therefore no details on the settings will be provided here.

Hercules 2-way Operations

Overview

Once all of the Hercules Setup is completed, you're ready to enable the 2-way communications. Campground Master will be linked to Hercules in much the same way as 2 workstations are linked in the Networking system.

The main difference between this and local networking is that Hercules can't initiate any communications with Campground Master -- Campground Master must initiate each exchange of data. While this means that online reservations aren't always "immediately" shown on Campground Master, it's close enough. Any online reservations not yet downloaded will be received as soon as a local action is initiated (when Campground Master checks for a site lock and synchronization), or when the polling frequency says it's time to poll -- whichever comes first. The important thing is that conflicts can't occur.

Initial Synchronization

If you have not already done so, and assuming you've completed the rest of the setup, then you should check the "Enable" box under Hercules Setup. That will start the communications task and begin the count-down to the next polling time (assuming Automatic mode). Nothing will happen immediately -- but if you begin to make a reservation or edit an existing one on a Site that's also available online, then it will begin communications.

The first time it communicates, it will automatically Send a Full Synchronization to Hercules. You can also do this manually, through the Hercules menu, if you don't see your reservations on Hercules (through their web interface). This function sends all local availability information to Hercules. After that, it will most likely Request a Full Sync from Hercules. This will verify that the sync upload worked, as well as check for any online reservations that we don't have locally. Again, it wouldn't hurt to request one manually, just so you know it's done.

If the synchronization goes well, you may see one or more of these Alerts:

ALERT -- ERROR -- Sync errors found in Hercules download synchronization

This can be expected one time during the first synchronization, especially if there are any online orders that were entered manually in Campground Master. You can safely ignore the first time this error (just "Dismiss" the alert). If it continues to appear, though, more attention is needed (see the Error Handling section).

ALERT -- Online Reservations received from Hercules

One or more Online Reservations have been automatically imported from Hercules...

This indicates that some online-created reservations were on Hercules that had not yet been imported to Campground Master (e.g. through the 1-way integration). This could be a normal situation, e.g. if you have not retrieved online reservations in awhile. Note however that if you had been manually entering the online reservations previously, then this may indicate that the online reservation has been imported as a duplicate, e.g. if you had assigned it to a different site when you entered it manually (so it didn't notice a conflict). You should review the imported reservations using the "Review Now" button on the Alert (or go to Reservations / View Recent Online Reservations), and make sure they are accurate and that they weren't duplications of previously imported reservations.

Note that when you "Review" the reservations, you may not see them immediately because the "View Recent Online Reservations" dialog it uses will default to just showing today's reservations. Adjust the "From" date as needed to go back and see older reservations.

ALERT -- ERRORS in Online Reservations received from Hercules

One or more Online Reservations could not be automatically processed....

This indicates that some online reservations were downloaded but could not be imported automatically due to some error (usually a conflict). While this could be actual double-bookings created prior to enabling the 2-way integration, this would commonly be due to manually entering the online reservations prior to enabling the 2-way communications. The online reservations will appear as conflicts with the ones you manually entered, when in reality they are the same reservation. It's important that you "Link" them so that instead of showing them as a conflict, they will be tagged with the appropriate online Order ID so they can synchronize properly with Hercules.

Another likely cause of this error is a mis-match of the "Space number" or missing space numbers (an error in setting up Site Data Fields).

Processing the errors

You will need to correct the errors before it will consider Campground Master "synchronized" with Hercules. To discover the cause and correct the problems, use the "Process Now" button on the Alert (or go to Reservations / Retrieve Online Reservations). This will get you to the Retrieve Online Reservations dialog. Any problem reservations will be shown in the list here as Unprocessed.

If you double-click on one of the reservations to process it, an error message should be shown reporting either a **conflict** or that **no matching site** was found.

It will then open another dialog showing the reservation details, where you could select an available site and "Save" the reservation -- assuming it really is a new reservation that needs to be imported. (Again, note that if it wasn't a conflict and didn't find a matching site for it, then that's a problem in the Site Data Fields setup.)

If it shows as a conflict, presumably because the reservation had manually been entered already and is thus a duplicate, then you need to use the "Link to an existing reservation" function to link the online reservation with the one already in Campground Master. Close/Cancel the Details dialog to get back to the list of reservations, select the reservation, and then click the "Link to an existing reservation" button at the bottom.

That will open a Find Reservation dialog, where you can enter the last name to locate the existing Campground Master reservation that matches the online request. **Tip** -- you may want to move the Find dialog around so you can see the online reservation information in the grid to help match up the customer, site and dates to make sure you have the right one.

Once you locate the desired local reservation and click "Use", the local one will be updated with the Online Order ID so they will stay synchronized. No other information from the online reservation is kept, since it should already be in the local reservation. The reservation will be marked "Saved" in the list to confirm this. Continue selecting each reservation listed to select a site or link it, and once all are "Saved" then close the dialog.

See the documentation on the Retrieve Online Reservations function for more details on this dialog if needed.

Other Synchronization Errors

If there are any problems with the synchronization, a dialog or Alert will appear with a list of problems. These may include local reservations that aren't on Hercules (failure to sync properly), or online reservations not in Campground Master, or reservations that have a mismatch in the data. These are covered in the Error Handling section.

Manual Mode

Downgrading to a Manual mode is not recommended due to the possibility of a conflict. It's considered "manual mode" any time you have either Incoming or Outgoing modes set to something other than "Fully

Automatic", and the Site Locking setting set to something other than one of the "Do locks & synchronization..." options. These settings are found under Maintenance / Online Reservations / Hercules / Hercules Setup / Operations.

If you need to use manual mode due to internet problems, or perhaps because the reservations aren't being imported properly (a Setup issue), then there are some things you need to be aware of:

- Naturally, conflicts can occur in this mode. The less often you initiate a manual upload or download request (through Reservations / Retrieve Online Reservations), the more likely someone online could book a conflicting reservation. If a conflict occurs, you'll be given the chance to assign the online reservation to a new site after you retrieve it.
- Also be aware that the customer is always sent a confirmation from Hercules when they make the reservation, even in Manual mode -- so if you have to make changes to the reservation then you should notify them of the changes.

To get Hercules site availability up to date when the Outgoing mode is manual, go to Reservations / Retrieve Online Reservations, make sure the Source shows "Hercules 2-way", and click the "Update Site Availability" button.

To get Campground Master up to date with any reservations when the Incoming mode is Manual, go to Reservations / Retrieve Online Reservations, make sure the Source shows "Hercules 2-way", and click the "Retrieve Online Reservations" button. If any are received, process them (see the Retrieve Online Reservations section for details).

Automatic Mode

For complete real-time communications and to eliminate the possibility of conflicts, you need to have both Incoming and Outgoing modes set to "Fully Automatic", and the Site Locking setting set to one of the "Do locks & synchronization..." options. These settings are found under Maintenance / Online Reservations / Hercules / Hercules Setup / Operations.

In this mode, Hercules is periodically polled for new reservations, and any new ones are automatically processed and added to Campground Master. Synchronization occurs not only at pre-defined polling intervals, but also any time you begin to make a reservation or edit an existing one on a Site that's also available online. It will do the following before every operation:

- Check for "Temp Holds" on Hercules, to see if someone is trying to reserve that site online at this moment.
- Lock the site(s) selected for the reservation, so it cannot be used online (if it's not already being used).
- Receive any new reservations made online since the last check.
- If a full synchronization is needed, either up or down, initiate that to get in sync.

All of this will happen automatically behind the scenes. You will only "know" it's happening if you get an Alert of new reservations received or sync problem, or if the site you're working on cannot be locked online (see Error Handling).

To clarify -- when a reservation is made on Hercules, you will normally **not** see it in Campground Master immediately, **only when** it's necessary to know about it to prevent double booking. For instance, when you start a new reservation in Campground Master, **then** it will sync with Hercules (or after your defined update period for periodic checking). So don't expect online reservations to pop into Campground Master immediately if you're not doing anything on it.

Automatic Reservation Processing

While there's an option to process the online reservations manually once they're received, this isn't recommended due to the potential for conflicts. However you can be notified when a new reservation is

received (which we recommend), and given the chance to immediately review it and make adjustments if needed. If everything is set up perfectly in the Parsing section of the setup, adjustments should rarely be needed. The online reservation is automatically converted into a Campground Master reservation on the site selected online, all customer data fields are imported, Deposit transaction added, etc., and it will appear on the Rack and other views immediately. If you have Auto-rates enabled, and have chosen the option to auto-calculate when a reservation is Created, then that's also done when an online reservation is processed.

However, one reason you should review all incoming reservations is to check for duplicate customers, so you can merge them into a single customer record (or check that customer's history for problems). This is done through the View Recent Online Reservations dialog, which will highlight possible duplicates and allow merging them, as well as highlight any where a possible duplicate has a Warning flag.

Manual Syncing to update Unavailable sites

You should do an occasional "Send Full Sync" (see Initial Synchronization), just to make sure Hercules is up to date with any dates you've set as Unavailable (and to double check for reservation sync issues).

If you need details on why this is necessary: While *changes* to the database always trigger automatic updates to the online availability, this does not address the issue of a moving time frame. Since the full sync only covers a limited number of days in the future, as those days not yet covered approach, the online availability information can become stale. The setting you use for "Max future days to upload" is an important part of this. For instance if Hercules allows reservations to be made 2 years in advance, but you tell Campground Master to only upload 365 future days, then you're already starting out with a 1 year gap -- it will appear as if the whole park is available after 1 year. If you set the "Max future days" to match the Hercules future allowance (e.g. 2 years), that's fine for the first day. But 1 month later, there's still a 1 month time frame at the end that Campground Master has not uploaded availability for.

Since new reservations are always uploaded, this is generally not a problem if you don't have any Season Dates or Special Dates Unavailable set in the Site Setup, and don't have any dates as "Special dates unavailable for online reservations" in the Hercules setup. Otherwise, the manual syncing is important.

Online Reservation Handling

Once a reservation from Hercules is imported into Campground Master, whether through the manual or automatic mode, you generally work with that reservation in Campground Master the same way you would any other reservation. If you change the site or dates, those changes will automatically be reflected on Hercules. So there is no need to go through Hercules to adjust the reservations or your "holds".

However, there are a couple things that require special handling:

Cancellations

When you cancel an online-originated reservation in Campground Master, it will automatically be removed from the Hercules grid appropriately (assuming the 2-way interface is enabled and in automatic mode). However, it does not cause any refund transaction to be processed in Hercules. You must manually process any refund due the customer, as described below.

Refunds

Whether due to a cancellation, a shortened stay or any other reason that some refund needs to be given to a customer, refund transactions done in Campground Master do not automatically go through Hercules. If you're giving the refund in cash or some other form of credit, you can do that in Campground Master and not worry about Hercules. However, we recommend that you process the refund on Hercules so the refund is credited to the original credit card that the customer used. There are two important reasons for this:

1. It will reduce charge-backs and other customer confusion by ensuring that the credit will show the same business name on their statement as the original charge, and of course will go to the same credit card.
2. It will reduce your costs by crediting the Hercules booking fee for the original reservation back to your account.

To handle the refund in both Campground Master and Hercules, you will need to follow these steps:

1. As with any refund in Campground Master, you will enter appropriate "reversed" (negative) Charge transactions to show that the service or product is not to be charged for. To do this, Manager access will likely be required. For details, see Working with Transactions.
2. Enter a Refund transaction in Campground Master for the amount to be refunded, and select the Payment Method you're using for the online reservations (as defined in Hercules Setup / Reservations). It's important to use this same payment method so that the refund comes out of the correct reporting account.
3. Log on to Hercules (through their web interface), and locate the reservation to be refunded. If it was a cancellation, it will no longer be on the grid so you will need to look it up. It will help to have the Online Order ID for it -- when you do the Refund in Campground Master, a message will appear with that ID -- otherwise, you can find it on the Reservation Details dialog in Campground Master.
4. Process the cancellation and/or refund in Hercules.

Viewing Recent Online Reservations

This dialog is access through Reservations / View Recent Online Reservations. It can also be opened directly from an Alert that new reservations have been auto-processed by the Hercules 2-way interface.

Here you can view all online reservations (those with an Online ID), according to Date Made. It defaults to the current day, but you can change the From date to view older online reservations, and also use the To date to see any specific date range.

Color coding

Reservations in the list are color-coded for 3 different factors:

Acknowledged -- These are show with green text (regardless of the background color used by the other factors). You can manually "acknowledge" an online reservation (click Mark Selected as Acknowledged), to show that you've done whatever you need to do to it. While it isn't necessary to acknowledge them, it can be handy if you have to process a lot of reservations and can't which ones you've verified. Note that there is no way to "undo" the Acknowledge, so use it with care.

Possible Duplicate Customer -- These are shown with a yellow background. Rather than just checking the name, this uses the same duplicate checking functionality that's optionally used when making local reservations. See Maintenance / Program Options / Reservations / Duplicate Customer Checking. If you want to try to merge a possible duplicate, select it and click Merge Duplicate Customers. See that section for details.

Warning Flagged -- These are shown with a red background. This indicates that the actual customer selected for the reservation has a warning flag. Note however that this doesn't indicate whether a possible duplicate of this customer is warning flagged. Thus if it's in yellow, meaning a possible duplicate, you should use the Merge function to find out if it's a duplicate of a warning-flagged customer.

Functions

Mark Selected as Acknowledged -- As mentioned above, this simply flags the reservation. Typically used after you've verified that the reservation is OK, checked for duplicates, etc.

View the Selected Reservation Details -- This goes to Reservation details (you can also just double-click the reservation), where you can review it and make any adjustments needed.

Merge Duplicate Customers -- As mentioned above, this allows you to check any possible duplicates and use the previous customer information instead of the new customer added for the online reservation.

Possible Duplicate Customers Found

This dialog is used when the "Merge Duplicate Customers" button is selected on View Recent Online Reservations. It will show any "suspected" duplicates, not based on name but using the same duplicate checking functionality that's optionally used when making local reservations. See Maintenance / Program Options / Reservations / Duplicate Customer Checking.

Detailed instructions are shown on the dialog itself -- basically you can select an old customer to use instead of the customer info submitted online (the information in the online customer record will be lost, so be sure to check for any differences and update the **old** record with the new information (using "View Selected Customer Details") before clicking the "Use Selected Customer" button.

Only one customer can be selected, which will replace the online customer. If you see other duplicates that should be merged, you'll need to do it through the Find Customer dialog (Customers / Find Customer).

View Diagnostics Window

This function, under Maintenance / Online Reservations / Hercules, opens a window showing the communications status and progress, and allows some diagnostic functions. Users should not perform any actions here unless under the direction of support personnel.

Send/Request Full Synchronization

These functions, under Maintenance / Online Reservations / Hercules, will send full availability information to Hercules, or request a full download of reservations and availability from Hercules. These can be used any time (form the Hercules Master only), but should only be used for initial synchronization or when a problem is suspected.

When invoking one of these two functions, a results window will be show if you wait for the response (e.g. don't open any other dialogs before the reply is received). Depending on the size of your park and number of reservations, it may take a few seconds to several minutes.

Unlock All Sites

These functions, under Maintenance / Online Reservations / Hercules, will send an "unlock" request to Hercules for all sites. This may be used if you suspect that some sites have been stuck as "locked" on Hercules (which can be seen on the grid in the Hercules web interface). Be sure not to use this if there are

any dialogs open locally (including any networked workstation), since that could unlock a site before it really should be unlocked.

Error Handling

Certain error and warning messages generated by the 2-way interface need to be acted upon to ensure proper synchronization. Some of the common messages and actions to take are covered below, particularly for messages that are not completely self-explanatory. (Note that the wording of the messages may not be exact.)

Synchronization errors

These general messages may be shown after a download synchronization (or possibly at other times):

Hercules response indicates that the 2-way interface is not supported for this account

If you see this message, you need to contact Leisure Interactive and have them enable the 2-way interface for your account.

Hercules response indicates that the password is incorrect

The Password you specified in Hercules Setup / Connections does not match the password set up on Hercules for the 2-way interface. (Or it's possible that the Customer ID is incorrect so it's trying to connect to someone else's account, so check that also).

Hercules response indicates that the Customer ID is incorrect

The Customer ID you specified in Hercules Setup / Connections is not recognized as a valid ID by Hercules.

Download synchronization received, with one or more new (or unknown) orders included.

This is a normal response after a Request Full Synchronization, meaning that there were new orders. Depending on your settings, you may need to process these manually (Reservations / Retrieve Online Reservations).

Download Synchronization results show some errors in Hercules data

This will be followed by a list of individual reservation mismatch errors:

Reservation should have been in download, but was not

This indicates that Hercules does not have the reservation online, but we have it locally so it should be on Hercules also. The 2 main causes of this are Hercules Space Number mismatches (so Hercules is not accepting the upload for the site, and you need to check the Site Data Fields), or a reservation made online was put in Campground Master manually so it doesn't have the proper Online Order ID associated with it. In the latter case, you may also get corresponding errors that Hercules has a reservation we don't have (and is available for processing), or possibly auto-processing errors reporting a conflict. Both of these can be rectified by going to Retrieve Online Reservations, where they should be shown as unprocessed, and use the "Link to an existing reservation" function to link the online reservation with the corresponding reservation in Campground Master.

Hercules reservation was not found locally (possibly new)

This most likely corresponds to a local reservation reported with the error above. It should now be in the queue to process -- and needs to be "Linked" to an existing reservation through Retrieve Online Reservations.

Hercules reservation was not found locally, but Order ID is blank so it's not 'new'
Hercules reservation was not found locally, but has a Record ID so we should have had it

Either of these is a severe error, since it indicates Hercules has a reservation we uploaded to it but we don't have it here. This should only happen if a reservation was deleted locally but somehow not deleted online. A Send Full Synchronization should resolve it.

Hercules shows this reservation on <space>, but we show it on <space>
Hercules shows this reservation starting on <date>, but we show it starting <date>
Hercules shows this reservation's last night as <date> but we show it ending <date>
Hercules shows this reservation as active, but we show it inactive

Any of these errors indicate a failure in communications, specifically something was changed locally but the change was not received or processed by Hercules. A Send Full Synchronization should resolve it.

Site Locking errors

One of these errors may appear when attempting a local operation (a response to a Site Lock). If it's a Warning, you have the option to bypass it and continue (but you'll need to deal with possible conflicts when the online orders are processed). It's generally recommended to cancel the operation, e.g. go back and choose another site or clear the cause of the error and try again.

Some online reservations have been received but not processed, so we're not up to date with Hercules data

This indicates that some reservations are in the queue to process manually (Reservations / Retrieve Online Reservations). This shouldn't normally occur in automatic mode.

We're not up to date with Hercules data (download in progress)

This indicates that it's currently downloading new reservations. You should try again in a few seconds.

We may not be up to date with Hercules data (initial synchronization not complete)

This indicates that it's in the midst of synchronizing. You should try again in a few seconds.

Hercules response to the site lock indicates that Hercules does not recognize the space number

The Hercules Space # specified in Site Data Fields for the chosen site does not match the space description on Hercules, or else that site isn't selected for "Online" availability on Hercules.

Site is currently in use for an online reservation in progress on Hercules.

This means that someone online is making a reservation for the same site (Hercules has a "temporary hold" on the site). Since the dates are not yet known online, and it doesn't know what dates you may end up with locally, there's a possibility of conflict. Note that a "temporary hold" may persist for up to 20 minutes even if they abandoned the online reservation. You have the option to keep trying (you should wait a few minutes between each try), or if the operator access level allows it then you can ignore the error and continue. Just be aware that if they do complete the online reservation there may be a conflict -- this would show as an Alert on the Hercules master workstation.

Hercules response to the site lock was not recognized

An error response or some other unknown response was received from Hercules. If this persists, it may require diagnosis of the problem using the Diagnostics window or log files -- check with technical support.

Either the 2-way interface is not supported for this account, or the Customer ID or Password is incorrect

Hercules is returning an error message indicating that one of those 3 conditions exists. This may be a problem with the settings in Connections, or you might need to have Hercules enable the 2-way interface for your account. To find out which condition is really the problem, Request a Full Synchronization from Hercules.

Hercules link is down, so we cannot check whether or not the Site is currently in use

The means it can't get a response from Hercules, or the communications is disabled (and cannot retry).

A timely response to a site lock was not received from Hercules

This could just be a temporary delay in communications, due to other operations or a slow interface. You should try again a couple times to see if it clears up. Also note that you need to make sure that Campground Master is not being blocked from the internet by any security software or firewall. You may see a warning from Windows Firewall, for instance, asking whether Campground Master should be blocked -- make sure you always "Allow", "Unblock" or "Approve" Campground Master. You should also check your firewall and security settings.

Alerts

These are the typical Alert messages that can be generated from the 2-way interface.

Online Reservations received from Hercules

If the Incoming operations mode is set to "Manual only" or "Automatic download but manual processing", this indicates that a new reservation has been downloaded but requires manual processing. The "Process Now" action can be used to go to the Retrieve Online Reservations dialog to process it.

If the Incoming operations mode is set to "Fully Automatic", this indicates that a new reservation has been downloaded and has been processed, but you may want to review it. Use the "Review Now" action to review it through View Recent Online Reservations.

ERRORS in Online Reservations received from Hercules

This occurs when using Fully Automatic mode if a reservation cannot be automatically processed for some reason -- e.g. an unknown site, conflict, missing data, etc. The "Process Now" action can be used to go to the Retrieve Online Reservations dialog to process it.

ERROR -- Sync errors found in Hercules download synchronization

This can occur after a synchronization was attempted, if comparison with the local data shows reservations either missing, extra, or different in the download sync received from Hercules. While this might be normal during initial synchronization before it gets completely synced, this should not be the case during normal operations after an initial synchronization.

The recommended action is to attempt a manual "Send full sync", followed by a "Request full sync", to see if it clears up. If you still get errors, contact support. It might be that there are some mis-matches in the Site Data Fields or some other setup issue.

Other Online Interfaces Setup

Overview

If you're not able to use the Hercules 2-way online integration, there are a few ways you can still interface with your own web site or another 3rd-party system that sends E-mail reservation data to you.

The specifics of the setup depend on which types of online requests you want to handle -- retrieving and parsing formatted E-mail requests, uploading vacancy grid pages to your own web site, or integration with an online reservation service.

Once you've decided which parts of the online reservation support you need to use, there are 4 or 5 major steps that need to be performed for setup:

- **Data Fields** -- Enable the appropriate data fields needed for online request processing.
- **Connections & Options** -- Set up the connection parameters required for each type of processing used.
- **Site Fields** -- Fill in the specifics of how each site will be used and identified for online requests.
- **Parsing Sets** -- Define the parsing rules for extracting data from the requests.
- **iCal Profiles** -- If you're importing or exporting iCal files, define the details through these.

Each of these is covered in detail in the following sections. See the "Setting Up" checklists for each type of online reservation handling for a quick guide to what's needed.

Data Fields Used

There are several data fields associated with retrieving and processing online reservations. These are all disabled by default to minimize database size for those not requiring this function, but they must be enabled before the online reservations processing can be used. See [Maintenance / Data Field Definitions](#) to enable data fields as detailed below:

For any online reservation processing:

The Reservations data field "Resv_Online_Request_ID" **must** be enabled for any online processing (except Exporting to a web vacancy grid). This is used to store a unique identifier for each online request, so duplicate requests can be ignored.

The Reservations data field "Resv_Online_Request_Raw_Text" can be enabled if you want the raw text of the online request (e.g. the actual E-mail data) to be saved with the reservation for future reference. It's not needed by the program at all, but might be useful if there's any question about what was actually in the request. You can view the request text through Reservation Details. **Warning** -- this will use a lot of space in the database, so if you expect to receive hundreds of online requests per year then this might not be worth the memory used. Instead, you could keep copies of the temporary download files before deleting them (but this requires manually copying the files in Windows).

Site Data fields

The Site data fields used depend on which type of online processing is needed. See the section "Online Setup - Site Data Fields" for details.

Setting Up for Export to Web

If you're interested in setting up Campground Master to export the web vacancy grid and upload it to your web site, the following areas need to be addressed. (See the related sections for details.) If you're not familiar with web site programming, we recommend that you get the assistance of your web site designer.

- Make sure you have FTP access to your web site, to upload the web pages once they're generated.
- Set up the FTP connection settings for uploading.
- Create one or more web page template files to be used when generating the pages.
- Set up the other configuration options through [File / Export / Export to Web Vacancy Grid](#).
- Enable the Site data fields "Site_Online_ExWeb_Ex" and/or "Site_Online_ExWeb_Release_Days" if you want to limit online or offline availability of sites.
- Fill in the Site data fields above with the appropriate values.

Note that this functionality is often used in conjunction with the E-mail Requests functionality, so a request form on your web site would feed requests to Campground Master through E-mail.

Setting Up for E-mail Requests

We refer to "E-mail requests" rather loosely throughout this documentation, but be aware that not just any E-mail request can be handled. A request must have a certain structure in order for Campground Master to extract the data from the E-mail text automatically, using Parsing Rules that you define. The request text is assumed to be some type of web form submission or formatted confirmation from a 3rd-party online reservation service. For instance, most web forms send an E-mail to you that have one field on each line, with a field name followed by the data. The parsing rules allow much more flexibility than that, but that's the general idea. See the Parsing Rules section for more details and examples.

In order to retrieve E-mail requests automatically, the requests must be available in a "POP3" mailbox. This is an Internet mail standard. However some E-mail services don't make this available, like America Online, and web-based E-mail services like Hotmail or Yahoo may not allow POP3 access. If you don't have a POP3 mailbox, then you will have to copy the text out of the E-mail and use the "Paste & Process" option to process the requests.

You will also need to make sure that any firewall or other security software allows Campground Master the appropriate types of access to the Internet. For instance it will need POP3 access to retrieve requests directly from E-mail, and FTP access to upload availability to your own web site.

It's also strongly recommended that you have a POP3 mailbox set up exclusively for online requests. While any non-request E-mails can be ignored automatically, there are other problems with trying to retrieve requests from the same mailbox as you use for your own mail. The main problem is that when you retrieve your E-mail from another program like Outlook, any requests that might already be in your mailbox will be deleted from the POP3 server -- so Campground Master can't retrieve them automatically. You would then have to copy them and use the Paste & Process option to manually process them. This can quickly turn into a nuisance and possibly missed reservations.

Of course if you're taking reservation requests from a form on your own web site, you may also want to show the current site availability and update it as often as possible. For this you can use the Export to Web Vacancy Grid functionality. This is covered in a separate section, but in general this is assumed to be the "upload" half of E-mail request processing.

To set up Campground Master to retrieve online reservation requests from E-mail messages (e.g. web site form submissions or online service confirmations, or from your own web site's reservation form), the following areas need to be addressed. (See the related sections for details.)

- Make sure the Reservations data field "Resv_Online_Request_ID" is enabled.
- Make sure you have a POP3 E-mail mailbox available that will receive the E-mail requests.
- Set up the POP3 connection settings for downloading E-mail (must at least be "Enabled" for some other setup functions to be available).
- Set up one or more Parsing Sets to extract the data from the E-mail. You'll need to know the format of the requests -- if using your own web site form, you might want to tweak it to make parsing easier and get as much information as possible in the format Campground Master uses.
- Enable the Site data fields "Site_Online_Email_ID" and/or "Site_Online_Email_Type" if the site name or type in the requests will not be exactly the same as the site name and type used in Campground Master. You also need to decide how you want to handle requests -- e.g. assign a site yourself, or use the customer's requested site if possible, etc.
- Fill in the Site data fields above with the appropriate values.

Connections & Options

Online Connections - General Setup

Currently there is only one option under the General section, but it takes some explanation.

Consider any dates past the "Release Days" as only available for Online Reservations -- Set this option if you want to consider sites as unavailable for local reservations if it's available for online reservations, according to the Release Days field(s) for each site.

As an example: If you have the Release Days for Export to Web set to 3, then that means the site is released from online availability 3 days ahead of time (3 days from today). That also means that it's available for online requests starting 3 days from now (e.g. someone could be reserving the site online for any dates 3 days from now or later). Therefore, you should avoid making local reservations for it that might conflict with the online reservations. Setting this option will make the site show as unavailable on the Rack starting 3 days from now (e.g. the first 3 days will be available, but after that it will be considered unavailable for locally made reservations).

Sites that are considered available for online reservations in this manner are shown in a different color on the Rack (a medium blue by default, different than the normal grey for unavailable). They will also be excluded from the list of available sites any time "Show Available" or "Available Only" is selected.

Note that if an attempt is made to create a reservation covering an online-only date, either a warning or error will be shown depending on the Access Levels setting and the current operator's level. If the operator doesn't have access to make local reservations for online-only dates, an error will be shown and the reservation cannot be saved. The access level required is Manager by default, but it can be modified through Maintenance / Park Setup / Access Levels.

Online Connections - Export to Web

Campground Master has built-in FTP (File Transfer Protocol) functionality for uploading web pages to your web site after using the [Export to Web Vacancy Grid](#) function. Some familiarity with your web host provider's uploading requirements is needed to configure this functionality. Obviously the first requirement is that you have your own web site, and that the web server that it's on supports uploading the web pages with FTP. It should also go without saying that the computer must have a connection to the internet.

FTP Settings are configured through Maintenance / Online Reservations / Other Online Interfaces / Connections & Options / Export to Web.

The basic settings are the same as for any FTP program. Contact your web host provider for the actual settings to be used (just ask for your "FTP configuration settings for uploading web files"), but example entries are shown below:

Host Name/Address: **mywebname.myhost.com**
Port Number: **21**
Protocol: **FTP**
Username: **myusername**
Password: **mypassword**
Remote directory: **public_html/vacancyfolder**

Note that the Remote directory should be a single "/" if the root directory is needed. If a sub-directory is needed, the entry should **not** start with a slash (but it can end in a slash) -- for instance, "www/" is correct, but "/www" is not correct.

Passive Transfer -- This option can be selected for most web hosts, but some will not allow it. If you're having trouble with the upload, try changing this option.

Online Connections - E-mail Requests

In order to retrieve online requests from E-mail, the appropriate settings need to be configured in Maintenance / Online Reservations / Other Online Interfaces / Connections & Options. This allows Campground Master to retrieve E-mail messages from a POP3 mailbox. (POP3 stands for "Post Office Protocol 3", which is a standard E-mail system used on the Internet.) These settings are similar to configuring most E-mail applications in Windows, like Microsoft Outlook.

To use the E-mail retrieval functions, Campground Master must be able to access a POP3 mail server via the Internet. For more details, see the Setting Up for E-mail Requests section.

Enable retrieval of online reservation requests from E-mail

This box must be checked to enable the E-mail portion of Online Reservations support. If this is not checked, the "E-mail" option will not be available in other Online Reservations functions.

Automatically connect to the Internet each time

If you use a dial-up internet service, you can select this option to connect automatically when it needs to retrieve E-mail (and it will also disconnect automatically when done).

POP3 Server Settings

You will need to enter the appropriate settings for accessing the POP3 mailbox. The host name/address is usually "mail" or "pop" followed by your ISP or web host domain name. An example is below:

Host Name/Address: **pop.myisp.com**
Port Number: **995** Use SSL
Username : **myusername**
Password : **mypassword**

If you have any questions about the proper settings to use in POP3 Setup, please contact your Internet provider.

Note: If you have anti-virus or security software like Norton Internet Security enabled for checking incoming E-mail, that may need to be disabled to prevent interference with Campground Master's retrieval process (only try disabling the security if you get an unusual error message when trying to retrieve E-mail messages).

Delete messages from server immediately after retrieving them

Use caution when choosing this option. Once you have things running smoothly, this can be selected if (and **only** if) the POP3 mailbox you're using is dedicated to online requests -- otherwise it would delete all of your other messages also, before you can download them with your normal E-mail program. If this option is not checked, messages will continue to accumulate in the mailbox (and take time to download each time), until you manually delete them. You could still delete messages by logging into the mailbox from another E-mail program, but you would have to be careful about deleting requests not yet processed.

Remember that all retrieved messages are also stored in a local file when they're retrieved, so even if you delete the requests from the mailbox but don't get a chance to process them, you can use the [Reprocess Downloaded Requests](#) function to get them from the downloaded file later (until you use [Delete the Downloaded Requests](#) of course).

Local Working Directory

This is where the downloaded requests will be saved locally, in a file named "email.txt". This defaults to a blank entry, which means it will use the same folder as the Campground Master database. If you prefer to put it somewhere else, enter the entire path name here.

Defaults for Online Deposit Transactions

If you're using a 3rd-party reservation service and they take a deposit for you, then you probably want to use a special Payment Method and Description for these deposits (since they're not coming directly into your normal account). If the payment description field is left blank, it will default to the payment method name.

You can also designate a special Operator name so you can identify them on reports. If this is left blank, the transaction and reservation will be recorded with the operator logged in at the time the request is processed. Note that even if you won't be receiving deposits online, you can set the operator name to be used in "Created by" for the reservations.

Note that if you enter a deposit locally after saving the reservation request, then these values aren't used for that deposit transaction (the current operator is used).

Online Connections - iCal

This has settings for both Importing iCal files and Exporting iCal files. These settings are configured through Maintenance / Online Reservations / Other Online Interfaces / Connections & Options / iCal.

For importing, there's just one setting here -- the checkbox to Enable iCal file importing. Without this enabled, iCal will not be an option under Retrieve Online Reservations.

For exporting, you need to check Enable exporting of iCal files. Technically that's all that's required to just Export the files (e.g. if you will upload them with some other software). However, Campground Master has built-in FTP (File Transfer Protocol) functionality for uploading the files to your web site after using the Export to iCal Files function. Some familiarity with your web host provider's uploading requirements is needed to configure this functionality. Obviously the first requirement is that you have your own web site, and that the web server that it's on supports uploading the web pages with FTP. It should also go without saying that the computer must have a connection to the internet.

The basic settings are the same as for any FTP program. Contact your web host provider for the actual settings to be used (just ask for your "FTP configuration settings for uploading files"), but example entries are shown below for a simple non-secure FTP connection:

Host Name/Address: **mywebname.myhost.com**
Port Number: **21**
Protocol: **FTP**
Username: **myusername**
Password: **mypassword**
Remote directory: **public_html/icalfolder**

Note that the Remote directory should be a single "/" if the root directory is needed. If a sub-directory is needed, the entry should **not** start with a slash (but it can end in a slash) -- for instance, "www/" is correct, but "/www" is not correct.

Passive Transfer -- This option can be selected for most web hosts, but some will not allow it. If you're having trouble with the upload, try changing this option.

Online Setup - Site Data Fields

This function (Maintenance / Online Reservations / Other Online Interfaces / Site Data Fields) opens a dialog to set up fields for each site which are specific to online reservation handling. The fields are listed in a grid format, like in Raw Data tables, because it's very helpful to edit them as a group and see the overall view.

Only the online data fields that are enabled will be shown -- so if you just see an empty list, you haven't enabled any of the expected fields (through Maintenance / Data Field Definitions / Sites). Of course this might not be a problem, depending on which online functions you need to use and which fields are required.

To change fields values, just edit them directly in the grid. Some values will be drop-down lists, depending on the type of field. You can also use copy/paste functions to copy a value to one or more fields.

WARNING -- any changes made here are instant and non-reversible, just like raw data tables. There is no Cancel or Undo function here.

Field Descriptions

Some basic field information is given here, but refer to the examples for more detail. Also refer to the [Online Reservations Setup -- Data Fields Used](#) section to see which fields you should enable.

For E-mail request processing:

Email Req. ID -- The site name or number you expect in E-mail requests for this site, which can be different than the Site Name for the sites. For instance, the name might be "RV Site 1", but in the E-mail requests it might be shown as "RV1". **Note:** If this field is enabled, you should use this field to identify all sites (and thus set this field's value for all sites and include it in your parsing rules) -- the "Site Name" field will not be used to automatically assign a site even if you include it in your parsing rules. If you expect all requests to include the exact Site Name of the selected site (e.g. if you're getting the site name directly from a pick list on the web form, or it's coming from Export to Web links), then don't enable this field.

E-mail Req. Site Type -- If requests will be made by the type of site rather than specific site numbers, you can set this to the expected value from the E-mail requests.

For Exporting to a web vacancy grid (on your own web site):

Exclude from Export to Web -- Set this to "Yes" if you want to exclude the site from the online vacancy grid. "No" and blank have the same result.

Export to Web Release Days -- Specify how many days ahead of time that the site should be removed from online availability. Leave it blank if it should always be considered available for both online and offline reservations. Enter 0 if it should never be available offline (locally), and always available for online reservations. See the section [Online Connections -- General](#) for more information on release days.

For Importing or Exporting iCal files:

Note that some of these fields are typically used in the various Expressions in the iCal Profiles. They are optional and depend on the particular functions and services used. You may also need to create additional custom fields for iCal exporting (see below). For the ones used in expressions, you only need to enter the unique portion for each site and could rely on the expressions to create the full value. For instance if you want the "Summary" field in the iCal file to read "{name} Cabin on beautiful Lake Meade", where {name} is the name of the cabin you want to show, then just enter the name in the Summary field and then define a Summary Expression in the profile that adds the "Cabin on beautiful Lake Meade" part.

Exclude from iCal -- Set this to "Yes" if you want to exclude the site from all iCal exporting. "No" and blank have the same result. Note that individual iCal Profiles can also filter the sites to be included for each service -- however this field will override that filtering and exclude the site from **all** iCal exporting if it's set to "Yes".

iCal Release Days -- Specify how many days ahead of time that the site should be removed from online availability. Leave it blank if it should *always* be considered available for both online and offline reservations. Enter 0 if it should never be available offline (locally), and always available for online reservations. See the section [Online Connections -- General](#) for more information on release days.

iCal Unavailable Dates -- Enter one or more date ranges to consider the site unavailable for online reservations. See the Edit Site Details function for details on date range formatting. Since there is only one iCal Unavailable field for the site, this should only be used for dates that you want the site considered unavailable for **all** iCal services. If you need different dates Unavailable for different services, you can specify that in the iCal Profiles (however that won't be site-specific). Also note that if you want the same dates to be unavailable for **all** sites, then it's easier to specify that in the iCal Profile rather than duplicate this field for each site.

iCal ID -- This can be used to uniquely identify the site when Importing iCal files, in conjunction with the Parsing Set pseudo-field "Unit ID from iCal". Note however that there is only a single iCal ID field, so if you're importing from multiple sources then it may be of little use. Identifying the site by the Import Filename is preferred, since that's defined in each profile and can come from a different source or field for each profile. Another possible use for this field is the identifying name of the site for exporting to iCal (it can be used in the expression for Description, etc).

iCal Summary / iCal Location -- These 2 fields can be used to specify the name or other information for the site, to be used in the SUMMARY and LOCATION fields of the iCal file. They will be used in the Profile's Expressions for those fields by default if they exist. If you need different Summary or Location information for different Profiles, then you will need to create additional custom fields and adjust the Expressions accordingly (see below).

iCal Export filename -- This can be set to a specific filename for exporting the iCal file (or even just part of the filename used in the Profile's expression), or you can leave it blank and let the profiles use the Site Name field in the default expression. If you need different file name information for different services/Profiles, then you will need to create additional custom fields and adjust the Expressions accordingly (see below).

iCal Import filename -- This is the most important field if you're Importing iCal files, since the service you're importing from usually specifies the filename for each unit/site. You would enter the unique filename that you would download (not including the URL/directory part that's the same for all sites). See the Profiles Setup for more details. If you import from multiple services then you will probably need different file name information for each one, so you will need to create additional custom fields and adjust the Expressions accordingly (see below).

Using Custom Fields for iCal expressions

If you need to create additional fields to use in the Expressions for iCal Profiles (specifically for the Location, Summary, Export filename and Import filename, but also any additional site information you might need in the Description), then you would do so by adding custom fields through Maintenance / Data Field Definitions / Site Fields. While it doesn't technically matter what Field Name you use for these additional fields, we recommend that you include "_iCal_" in the name so that it will be recognized as a field for iCal usage and will therefore be included in the Site Data Fields list. Otherwise you would have to go to Raw Data Tables to edit the fields. Make sure you include the underscore on each side of "iCal". For instance, when naming a field for the export filename for AirBnB, enter "Online_iCal_Export_AirBnB" (which will be added to "Site_User_" to become "Site_User_Online_iCal_Export_AirBnB").

Online Setup - Parsing Sets

Overview

The parsing engine in Campground Master is the "brain" behind automatically processing online reservations for E-mail requests. The parsing engine is used to examine and extract the reservation data whenever you use the functions in [Online Reservation Requests](#) to retrieve online requests, re-process downloaded requests, or paste & process requests.

Setting up the parsing rules for the engine is almost like writing a little computer program. The rules are used by the engine to look through the text of the request and figure out how to extract the customer's name and address, the dates they want to stay, what kind of site they want, and all of the other vital information for the reservation. Obviously some experience with programming or database manipulation is helpful, but if you're patient and follow the examples then you should be able to set it up. See the Parsing Rules Technical Details section later for more information.

"Parsing" Defined

"Parsing" is a computer term that generally means manipulating or extracting useful information out of some data. In this particular context, it means extracting the various bits of reservation data out of the E-mail text or other downloaded data.

Parsing Sets and Parsing Rules

A parsing "set" is a group of parsing "rules". Each parsing rule is like one command in a computer program, defining where to find a single data field like the customer's name. A set of these rules, along with a few other parameters, is a parsing set that defines how to extract a complete reservation from one bunch of data, for instance one E-mail message.

The parsing sets are divided into sections depending on the source of the request -- E-mail requests and Reservation Friend (the old 1-way E-mail interface). This helps avoid confusion for both you and the parsing engine. However each section can have any number of parsing sets. For instance if you receive E-mail requests from several different online reservation services, you would create a separate parsing set for each service (since the requests would most likely be in different formats for each service).

In some cases you might even have separate sets for different types of requests from the same source. For instance if you have two forms on your web site that ask different questions, like one form for camping sites and one for cabins, you can set up a separate parsing set for each form. You just need to have some unique text in each type of request so that Campground Master can tell them apart and use the right parsing set for it.

Reservation Friend Default Parsing Set (only used for the old 1-way interface)

The general format of the reservation data E-mails from Reservation Friend is already known, so a default parsing set has been set up in Campground Master. When you first select Reservation Friend for the parsing set type, this default will be loaded automatically.

However, you may need to make some changes to the parsing set in order for it to work completely. In particular, you may need to configure it to work with your specific reservation options (50A, extra adults and other "adders"), and for your Rig Type selections. Since the same parsing engine is used for Reservation Friend as for E-mail requests, refer to those sections for details.

E-mail Parsing Sets

Since there is no standard format for E-mail requests, you will have to set this up on your own. However there are some examples later to help you get started.

Parsing Rule Details and Examples

The basic functionality of the setup dialogs will be covered first, followed by detailed information about parsing rules and some practical examples.

Setup Parsing Sets Dialog

To add or edit parsing sets, go to Maintenance / Online Reservations / Other Online Interfaces / Parsing Sets.

Parsing Set Type

This is basically equivalent to the "Source" selection for retrieving online reservations. Select the appropriate type of request for which you want to set up parsing sets, e.g. E-mail requests or Reservation Friend 1-way.

Parsing Set List

This works the same way as the Rates setup dialog, in that it shows a list of defined sets (of the selected online parsing set type), and has functions for Edit, Add, Insert, Delete, Copy, Move Up and Move Down, plus the standard Print and Export functions.

To edit a parsing set, for instance, just click the one to be edited and click the [Edit parsing set definition](#) button. Or you can just double-click on it to edit it. This will open the [Edit Parsing Set](#) dialog.

To add a new parsing set, click the [Add parsing set definition](#) button. The same dialog that's used for editing is used to add a new set.

The order of parsing sets can make a difference if you're checking for multiple request formats and use different Identifying Text for each set. They will be processed in the same order that they appear in this list. The one with the most specific identifying text should be at the top. (It would actually be pretty unusual if the identifying text was ambiguous enough that the order would matter anyway, since it's a good idea to make it as specific as possible.)

If you have a parsing set that works great but you need to set up another one that's almost the same, you can use the Copy function. This will also duplicate all of the parsing rules for the copied set(s). This can be handy if you get different requests in the same format except for a small difference. Of course the Identifying Text needs to be able to distinguish the two sets also (more on this in later sections).

Warning -- if you Delete a parsing set, all parsing rules associated with it are immediately deleted too. While this should be obvious, we mention it as a warning because one accidental "Delete" could wipe out a whole lot of work on parsing rules.

Importing and Exporting Parsing Sets

These functions allow copying a parsing set from one database to another (or between computers). This is primarily used if you have your software provider do the setup on another system and then need to import that setup to the working database on your computer.

The Export function creates a text (CSV) file in a special format that the Import function can read. This can include one or more parsing set definitions (select the entry or entries to export before clicking the Export button). To complete the export, select the location (Save in) and the file name for the exported file with the "Export" file dialog is shown.

The Import function is simply the reverse of Export -- select the CSV file containing the exported parsing sets, and Open it to import them into your database.

Edit Parsing Set Dialog

When you Edit, add New or Insert a parsing set from the Setup Parsing Sets dialog, the Edit Parsing Set dialog is used.

This dialog defines one parsing set, which consists of 4 items:

Set name

This is for your use to identify the set when listed in the Setup Parsing Sets dialog, so just make sure it's different for each set you define.

Identifying Text

This field is important for the parsing to be successful. This is particularly important for E-mail requests, since other types of E-mail need to be filtered out from processing.

Each parsing set should have a different identifying text value so that the parsing engine can determine which parsing set to use for any given E-mail. Furthermore, it should be something unique that not only identifies an E-mail as being a request (as opposed to some other junk E-mail), but also distinguishes requests that need to use this parsing set from requests that need to use a different parsing set. Remember that it will look at the E-mail header in addition to the text of the E-mail, so it's common to use the "from" E-mail address or the subject of the message to identify it. Some simple examples are below:

- **"request@reservationservice.com"** -- This parsing set would only be used for an E-mail with that address in it, which presumably would only be E-mail requests from that online service.
- **"Form: Cabin Rental Request"** -- This parsing set would only be used for and E-mail with that text in it, which would presumably be the subject of messages sent from the cabin rental form on your web site.
- **"RIG_LENGTH_REQUIRED"** -- This parsing set would only be used for and E-mail with that text in it, which is one of the field headers in messages sent from the RV space rental form on your web site (and presumably not present in the cabin rental form, for instance).
- **(empty)** -- If you're using an E-mail mailbox that's dedicated to requests (so the mailbox doesn't get any other junk E-mail), and you only expect one type of request, then you can leave the identifying text blank (don't actually put the word "empty" in it). You could also have a default set with blank identifying text, but make sure it's the last one in the list so any others are checked first.

Try to use something as unique as possible, but don't worry if some other E-mail happens to come in with that text in it by accident. The program will try to parse it, but will simply show an error if the E-mail message doesn't have all of the other fields defined by the parsing rules.

Note that the identifying text is **case sensitive!** Make sure you have any capital letters exactly as they will appear in the E-mail.

Parsing Rules

This is a list of all parsing rules defined for the set. As with the Setup Parsing Sets dialog, the standard Edit/Add/Insert/Copy/Delete/Move functions are available.

The list of rules is a little different than other lists. The "Rule Details" listed will be shown in a format determined by the type of rule and the basic settings for it. This can take some time to get used to, but basically it just shows the type of rule, and the main parameters of the rule (begin/end text, etc.). For instance, rules that have a before and after text and presumably extract some data between them will be shown like "Before___After", where the underline is assumed to be where the extracted text will be. Rules that have the "Append" flag set will have a "+" at the beginning of the rule details. Rules that use the "After previous field" location will have a "..." in them to indicate this.

Notes

You can add notes to the set if you like, which will just be shown in the list of sets in the Setup Parsing Sets dialog.

Save and Test Parsing Set

As you're setting up your parsing rules, it's helpful to test them frequently to see how they're working. You'll probably want to do this after each new rule is added at first, but don't get lazy about it -- you should test it with various combinations of data before trying it for real requests.

Entering Test Data

When you click "Save & Test Parsing Set" on the Edit Parsing Set dialog, a large window will open where you can enter sample data, for instance a sample E-mail that would need to be parsed. You can type in the data manually, or copy and paste it from another program.

If you already have an E-mail request that you've received, then naturally you would want to use that to test with. Just copy/paste the E-mail text into this window. However it gets even easier the next time -- the last test data used with each parsing set is saved in the database, so you don't have to paste it in each time. Of course you will eventually want to test with various requests with different data, etc. to make sure it works for any possible combination.

E-mail Message Text

When testing the parsing rules for E-mail requests that you expect to eventually have Campground Master retrieve directly from your E-mail box, you should include the full header and raw text as it comes from the POP3 server. Depending on your E-mail program, this means selecting a "Full header" option, or perhaps a "View Source" option to see the raw E-mail text. If you can't find a way to do this, then you may need to get the E-mail request connection portion functioning so you can actually retrieve an E-mail from the server through [Retrieve Online Reservations](#), then copy that E-mail text from the "email.txt" file (where Campground Master puts retrieved messages). If you're working with Reservation Friend requests instead of E-mail requests, the E-mail text will be in the file "email_friend.txt" instead.

Testing the Rules

Once you have the test data entered, click "Test". It will parse the data using the current parsing rules for this set, and also check to make sure the Identifying Text for the set is present. If there's an error in the rules definition or other serious error, it will show an error message. If there is no error that aborts the parsing, then the [Online Reservation Request Details](#) dialog will be shown, just as if you're processing a request received the normal way. Any fields parsed successfully from the data will be shown in the list, so you can check the accuracy of the parsing rules. Of course the "Save" functions are disabled since this is just a test.

Edit Parsing Rule Dialog

When you Edit or add a New parsing rule from the Edit Parsing Set dialog, the Edit Parsing Rule dialog is shown.

The basic method of entering a rule is to set each of the fields in this dialog, in top to bottom order (some fields will be disabled based on the Parsing action choice, so not all fields need to be entered in all cases).

The details of all the different types of rules and how they're used is covered in the section [Parsing Rule Technical Details](#).

Where to look for field -- This has two choices, "Anywhere in the text" or "After previous field".

Parsing action -- There are several choices for what to do if this rule is satisfied. Just select from the list.

Text before field, Text after field, Compare to, and Set value to -- enter the text for any of these that are needed, according to the selected parsing action.

Number of Characters -- enter the maximum number of characters to extract (from between the Before and After text), or the exact number of characters to extract if the After text is blank.

Field descriptor -- This is the Campground Master data field (e.g. reservation, customer, or transaction field) that will be set to the value resulting for the parsing rule. It will show the descriptor in text here and you can edit it, but the easiest way to set the field descriptor is to use the **Select Field** button, which opens the [Select a Data Field](#) dialog.

Append to any previous text for the same field -- Select this box if you want the parsed text to be added to the field instead of replacing it. For instance there may be several bits of information in the request that you want to put in the Reservation Notes.

Convert to Mixed-case, Convert to UPPER-case -- select one of these if you want the parsed text to be converted automatically. This is commonly used for names and addresses, in case the customer didn't use the proper capitalization.

Trim any extra leading and trailing spaces from the value -- Actually all data fields are ultimately trimmed before being saved into a reservation, so this option is checked by default. However this option can be disabled for intermediate parsing, for instance when appending several bits of text to one field. This allows you to insert spaces where needed or keep any spaces in the extracted data.

Notes -- You can add any notes you want, which could be handy for an unusual parsing setup that you may need to figure out at a later date. This dialog is the only place these notes will be shown.

Select a Data Field Dialog

This dialog is used to select a Campground Master data field (e.g. a reservation, customer, or transaction field) to be used in a parsing rule. It will open when using **Select Field** or **Insert Field** from places such as the [Edit Parsing Rule](#) dialog or Edit Query Column dialog.

The [Data Field](#) list below the table selection will show fields that can be used for the selected [Data Table](#) ([record type](#)). It may also have "pseudo-fields", which aren't real fields in the database but can be chosen just like a real field to handle the parsed text a certain way. For instance if you choose "Number of Nights", it will actually use the given value to calculate the real Last Night field value when parsing the text.

It may have a [Linked/Relational Data Field](#) list on the right-hand side, which will only have fields in it if the field you choose on the left is a relational (linked) field. For instance if you're looking at Reservation fields and select the "Customer" field on the left (which is a relational link to the customer data table), then all Customer fields will be shown on the right. When there is a list on the right, you must choose one of those fields for the selection to be valid. So for instance you could choose "Last Name" from the list of customer fields. Note that in this case it would have been the same thing as selecting "Customers" directly in the [Data Table](#) list and then selecting "Last Name" in the left-hand list -- it's just two ways of getting the same result.

Once you've selected the desired field, click OK and it will return the appropriate field information. As a shortcut, you can just double-click on the desired field.

Parsing Rules Technical Details

Parsing rules are pretty simple at the basic level of "if you find this then put the text here". This section covers the technical stuff -- for some actual examples that are easy to understand, see the next section with the [Parsing Set Example](#).

Types of Rules (Actions)

If you're getting data from a web form that you design or have designed for you, then it should be easy to set up the rules because you would naturally design the form to ask for all of the information in a format that's very similar to the Campground Master data. In that case, most or all of your rules will be the basic "Extract Field Value" type and will be very simple to implement.

Other types of rules are available to handle special situations that would mostly be an issue if you're trying to parse a request from some other service that uses different types of data. For instance, they might have a field that has the dollar charge for extra adults but does not give the actual number of adults, like Campground Master needs it. You could use the rules to convert various charge amounts into the appropriate number of adults.

Each action type, or rule type, is detailed below. Each type of rule accepts different parameters (before, after, compare-to or set-value text), depending on its function. All of them also need a field descriptor and allow other options like append and convert options, except the Ignore Field rule. Note that the number of characters can be specified also, but to keep it simple this option is covered separately below.

Extract Field value

This is the basic rule used to extract text from the data and set a field value to that text. All you need to do is enter the text that will appear before the value (before-text) and the text that will appear after the value (after-text). For instance, if the request has the customer's last name after the label "LASTNAME:", then enter that label for the before-text. You also need to tell it where to stop extracting the value, so for instance if you know there won't be anything else on that line, enter "\r" (carriage return) for the after-text.

You can leave the before-text blank if you want to start extracting immediately from where the position pointer is in the data -- this assumes that the Where to Look is set to "After Previous Field".

Extract Field value if not equal to 'Compare to'

This rule is similar to the previous one in that it looks for the field between the before and after text, but it also lets you specify an exception to extracting the data. In addition to the before and after text, fill in the Compare-to text. The data found will be extracted only if it does not match that text. For instance, the request might specify a site number, or "N/A" if they don't select a site. Use this rule to extract the site number specified as long as it's not "N/A".

You might wonder why there's not a rule to extract a field value if it *is* equal to the compare-to text. That's because the "Set Field value if Compare to matches" rule below can do the same thing.

This rule can also be used to extract a field value only if the text is non-blank, by leaving the Compare-to text blank. In other words, rather than just extracting a blank field, it would skip the extraction and not set the field at all.

Set Field to a fixed value (always)

This rule doesn't actually extract anything from the text. It simply sets a field value no matter what (assuming this parsing set is used). You just enter the set-value-to text for the field.

This rule is generally used to set a default value, for instance to set the How-found field to a specific value for all online requests, or perhaps to set a default for the number of adults in case they didn't specify it in the request. Remember that a rule could follow later in the set that extracts the field if it does find the value in the request, which would replace the default value.

Set Field value if 'Text before field' is found

This rule is similar to the previous one, except it looks for some before-text and only sets the value you specify if that text is found (ignoring anything else actually in the request). This would be used for things like special options that appear as unique words in the request. For instance if the request would have something like "2 ADULTS" in it for the number of adults, it's hard to extract a value appearing before the text. So you can add a number of rules, one for each reasonable number, such that each rule would set the # Adults field to the specific value it finds (e.g. if it finds "3 ADULTS", set the # Adults field to "3").

Set Field value if non-blank data is found

This rule looks for before and after text like the normal Extract rule -- but instead of setting the field value to the extracted text, it will set the field to a specified value as long as the text between the before and after text is not blank. (Remember that whitespace characters like space, tab, carriage return and line feed are considered blank.

Set Field value if 'Compare to' matches

This rule looks for before and after text like the normal Extract rule -- but instead of setting the field value to the extracted text, it will set the field to a specified value as long as the text between the before and after text matches the compare-to text. As an example, lets say the request is expected to have either "Electric: 50A" or "Electric: 30A". If you have a preference field for 50A (which must be set to "Must Have" to show that they want 50A), then you could use this rule. Set the before-text to "Electric:", the after-text to "A", the Compare-to text to "50", and the Set-value-to text to "Must Have".

Set Field value if 'Compare to' doesn't match

This is similar to the previous rule, except that the field will be set if the data does *not* match the compare-to value.

Set Field value if no previous value was set (default)

This rule is intended as a catch-all case, for instance if you have several Set Field value rules for the same field, checking for various conditions, and then need to set the field to a particular value if none of the other checks produced a value. This is essentially defining a default value.

Note that the "previous value" it's looking for is according to the Field Descriptor, not just the same before and after text in previous rules. So if you have several rules looking for an "Electricity" value but the rules actually set different data fields (e.g. 50A, 30A, and 20A preference fields), then this doesn't act as a default for "Electricity" -- it would only act as a default for one specific data field.

There is a subtle difference between using this at the end of the other comparisons and just setting the field to a fixed value as a default before the comparison rules (whereas the default field value would be overwritten if one of the comparison rules were satisfied). The key is that this particular rule does nothing unless the before and after text is located, so the field will not get set at all if the request does not have the before & after text.

Ignore Field (set position for next field)

This rule only has one parameter, the before-text, which is just the text that you're looking for to activate this rule. This rule doesn't set any fields, it just looks for the specified before-text, and if it's found then the position pointer for following rules is set to that position (on the next character after the before-text found).

Obviously this rule only has a use if there is a rule following it that has "After previous field" for where to look. It can be useful for setting a starting point, for instance if a number of fields are in a known order without unique labels in front of each one. Just locate some identifying text that comes before all of the values -- for instance the request may have a label "Address:", which is known to be followed by several lines with the pieces of the address. Use the Ignore Field rule to find "Address:", and then a number of Extract Field rules with blank before-text to read in the data fields sequentially.

Number of Characters vs. Text after field

Any rule that has "Text after field" as a parameter will also have "Number of characters" as an option. Either or both of these values can be specified, depending on what you need to do.

If the after-text is specified but the number of characters is blank (or zero), then it will simply extract all of the text between the before and after text as described in the actions above.

If the after-text is blank but the number of characters is 1 or more, then it will extract exactly that number of characters (starting after the before-text), and leave the position pointer at the next character. This is useful for parsing data values of a fixed length, especially from a string of data with no labels or field dividers.

Remember that you can also leave the before-text blank, so it starts exactly where the last rule left off. Note that if it reaches the end of the request before the required number of characters are found, it will just keep what it finds -- this can be used to just extract everything to the end of the request, for instance if there are notes of unknown length at the end, with multiple lines and no unique ending character to stop with.

If both the after-text and the number of characters is specified, then the number of characters is assumed to be a maximum. So it must find the after-text, and the position pointer will be moved to the next character after that as usual, but if the data extracted between the before and after text is longer than this maximum number of characters then it will be truncated. For instance, this can be useful to extract just a fixed part of a line but leave the position pointer starting on the next line.

General Parsing Rule Order

There are a couple restrictions for the order of parsing rules in a parsing set. Regardless of the order that the fields appear in the request text, the order of parsing rules must follow these guidelines for successful parsing:

- Reservation fields and Customer fields can be in either order and intermixed if needed. However there must be at least one Reservation field **and** one Customer field successfully parsed before a Transaction field can be parsed (due to the required linking relationship).
- If you're extracting more than one Transaction, using indexed records like Trans[1], Trans[2], etc., don't intermingle index values and keep them in order -- e.g. all rules for the first transaction must appear before any for the second transaction. See below for more information.

Indexed Records in Field Descriptors

As just mentioned above, it's possible to extract data for multiple transactions for a single reservation request. This is handy for adding memos or other items to the transactions for the reservation. This is generally used only for transactions.

To create a parsing rule to do this, you must modify the field descriptor manually, e.g. after using Browse to select the field on the Edit Parsing Rule dialog. Insert an index number inside square brackets, just before the colon of the field descriptor -- for example: "Trans[0]:Tran_Amount". The index value can start at 0, and go as high as needed. If no index value is specified, [0] is assumed.

The index values must be in order in the parsing rule list, e.g. all fields for Tran[1] must appear before Tran[2] fields, [2] before [3], etc. However you can skip index numbers if you like (to leave room for inserting others later, for instance). It's also OK if data isn't extracted for all transactions, resulting in missed index numbers. For instance if it extracts fields for Trans[1] and then doesn't find any rules (or valid data to extract) for Trans[2], it can still extract data for Trans[3]. Only the two transactions found will be used. The numbers are just a way to create separate records and indicate which fields go with which record, but the numbers themselves are not important.

When you view the Online Request Details, the indexes shown for extracted data will appear a little differently -- they will have a "+" number in front, like "Transactions[+1]". These numbers may not match the index values you use in the rules -- they will increment without gaps in the numbering.

Using "After Previous Field" for Where to Look

Aside from the general order of fields mentioned above, the order of the rules don't matter if the "Where to look" for all of your rules are "Anywhere in the text" because it will start at the beginning of the request data each time. But if you use the "After previous field" option, then naturally the rules need to be in the same order that the fields to be extracted will appear in the request data. Therefore it's recommended to use the "Anywhere" option unless there's a specific requirement for getting fields in a certain order without looking for unique text to indicate the field position.

To be more specific -- as the engine goes through the rules, it keeps track of the last position it looked at (e.g. where it found the last field's data). If you select "After previous field", it starts looking from that position to satisfy this rule (e.g. to find the "before text" for the next rule). If a rule uses "Anywhere in text", the engine starts over at the beginning for that rule.

Note that sometimes every character is important for locating data. Lets say the following text has 3 values that you need to extract, where the first number is # adults, the second is # children, and the 3rd is # pets:

Extras: 1,2,3 (end of line)

You can do this with 3 parsing rules, each with Extract Value for the Action:

- The first rule would be a "Look Anywhere" rule, with "**Extras:**" for the before-text and "," for the after-text. It would extract the value "1" which appears between the specified text (the leading space is removed). After getting that value, the text position pointer is now on the "2" (it's positioned on the character following the after-text specified in the previous rule).
- The 2nd rule would be a "Look after previous field" rule, with blank before-text (so it starts extracting immediately starting with the "2"), and after-text ",". So it will extract the value "2", and the pointer is left on the "3".
- Finally the 3rd rule would be another "Look after previous field" rule, with blank before-text and after-text "\r" (to stop at the end of the line) so it extracts the "3".

There is also a special way to position the pointer for future rules without extracting the text. This is the "Ignore Field" rule action. Specify the before-text and it will locate that text, leaving the position pointer on the next character (after the before-text it found). This could be useful in the example above if you wanted to skip the first value, for instance. The first rule would have an action of "Ignore Field", then you would insert another "Ignore Field" rule with "," as the before-text. This would move the position pointer to the 2nd value ("2"), setting the stage for the next rule to extract the 2nd value.

Special Characters and Text Considerations

When entering a rule, there are certain limitations for what you can use in the before-text, after-text, compare-to and set-value-to fields (and there are some workarounds for these limitations).

- You can't enter the space character at the beginning or end of the entry fields (because leading and trailing spaces are stripped out of the dialog entry fields automatically). However if you need to have the parser actually use a space, for instance to enter a space character in the "Set value to" field that's not surrounded by other characters, you can use the hexadecimal escape sequence "\x20".
- You can use the \t and \r escape sequences in the before-text and after-text values to look for "tab" and "carriage return" characters respectively. For instance it's common to have "\r" for the "Text after field" setting, to tell it that the data stops at the end of the line.
- Sometimes text data includes both carriage return and line feed characters at the end of lines. All line-feed characters in the request text are removed before parsing, to make it more consistent and avoid confusion between the two characters. Therefore lines will always end in a carriage return character (\r). Also note that there may be more than one \r at the end of lines, so don't assume only one will be there when setting up parsing rules.
- When text is extracted (e.g. from between the before-text and after-text), any carriage return or tab characters are converted to spaces (because Campground Master data fields cannot contain control characters). In addition, leading and trailing spaces are removed from the parsed text before doing any comparisons -- keep this in mind when setting a "Compare to" value -- the extracted text being compared would never contain the carriage return (\r) or tab (\t) characters, and it could not start or end with a space.
- Before-text and After-text values **are** case sensitive and must be entered exactly as they will appear in the request text.
- For the Compare-to actions, the comparison is **not** case-sensitive (e.g. the compare-to text "tent" will match "TENT" in the request).
- Text in Set-value-to is naturally case sensitive (the data field will be set to exactly that text -- after any spaces are trimmed from the ends of course).

Requirements for a Valid Reservation Request

Regardless of the actual rule definitions used, a Parsing Set is "complete" as long as it contains rules that result in the following fields being extracted from a given request:

Reservation : First Night
Reservation : Last Night
Customer : Last Name

That's the minimum amount of information needed for a reservation to be created, so your parsing rules need to at least get this information from the request text. Ideally you want to get as much information out of the request as possible, though, as long as the format is reliable enough to avoid getting false information.

Note that the pseudo-field "Departure Date" or "Number of Nights" can also be used to get the Last Night value.

In addition, an **Online Request ID** must be present, either found by default or extracted using a parsing rule. The logic is as follows:

- For E-mail requests, it looks for the "Message-ID" header and will use that for the request ID by default.
- You can also set up a parsing rule to set the online request ID, which will override any extracted from the Message-ID. You may want to do this to get a specific ID from the request itself for later reference, or you may need to do it if you have to paste text to process that doesn't have the E-mail header information.
- If no request ID is found or parsed, an error will be shown. The request cannot be saved as a real reservation without an ID, but if you view the request you can enter a request ID manually (just be sure to use something unique that would never match an ID from another request.)

Default Field Values

Reservations - Several reservation fields will be set to default values if they're not parsed out of the data:

Confirmation # - uses the formatting rules specified in online setup
Status - set to "Pending" unless the Guarantee Info field is filled in, then it will be "Guaranteed"
Reservation Type - set to the default specified in Program Options
Date Made - set to the current date
Time Made - set to the current time
Operator Made - set to the current operator, or the default specified in the online setup

Transactions - If the request includes any transaction information (for instance a deposit amount), then you can also create one or more transactions for the reservation. The only value you actually need to create or extract is either the Each amount or the Total for the transaction. The rest of the fields will default as follows, if they're not explicitly set by the rules:

Transaction Type - set to "Deposit"
Transaction Category - set to the same as Transaction Type (e.g. "Deposit")
Quantity - left empty
Each - set to the same as the Total amount, or Total / Quantity if there's a quantity
Total - set to the same as the Each amount, or Each x Quantity if there's a quantity
Receipt # - set using the normal formatting for receipt #'s
Description - set to the default specified in the online setup
Payment Method - set to the default specified in the online setup

Operator - set to the current operator, or the default specified in the online setup
Date, Time and **Shift** - set to the current date, time and shift

Note: If you have parsing rules for transaction fields but the resulting Total is zero after parsing (unless it's a Memo transaction type), then the transaction will not be added to the reservation. For Memo transactions, the Description field must be non-blank for it to add the transaction.

Duplicated Fields

When making a reservation manually, some values you enter are automatically copied to matching fields in both the Reservation and Customer records. However this does not happen for online reservation parsing, so the following fields need to have duplicated rules for the associated Reservation and Customer fields if you want the data to be set in both places:

- # Adults
- # Children
- # Pets
- Extra Vehicles
- Extra Trailers

Exception -- the Guarantee Info field is copied from the Reservation to the Customer automatically.

Also note that the **Discount Used** reservation field is normally copied into the next available customer Discounts field (#1, 2, or 3) when entering manual reservations. Since this complication isn't possible when parsing, just extract the reservation's Discount Used field. The next time you enter Transactions, the discount will be carried over automatically to the customer as appropriate.

In general it's OK to parse the same text multiple times, or even set a data field value multiple times. If a field is parsed out that already had a value, the new value will replace the old one unless the "Append" option is specified.

Date Formats

When parsing date fields, the date must be in a recognizable format. There are a few different formats that are recognized, shown below.

Mon dd, yyyy - e.g. Mar 25, 2007 -- Month must be 3-letter English abbreviation

mm/dd/yyyy - (or d/m/y for non-U.S.) e.g. 3/25/07, 03/25/2007

Mon/dd/yyyy - e.g. Mar/3/2007

yyyy/mm/dd - e.g. 2007/03/25

yyyy/Mon/dd - e.g. 2007/Mar/25, Month must be 3-letter English abbreviation

Note that a dash or period (- or .) can be used instead of a slash (/), and that the day or month numbers can be with or without leading zeroes (e.g. 3 or 03). Except for the formats where the year is first, the year can be either 4 digits or 2 digits. Where the 3-letter month abbreviation is used, it can be upper or lower case, or mixed.

Pseudo-Fields

There are several "fake" fields that can be used to help get the data parsed into useful values. These pseudo-fields appear in the list of fields in the Select a Data Field dialog (at the top, above the normal fields). These special fields are described below, noting any special handling that can be done.

In general you can use a parsing rule to extract text from the request into a pseudo-field instead of a real data field, to handle special formats that the request might use. The engine will do further processing on that text to set the real Campground Master data fields appropriately.

"Append" option note -- In all but a few cases, the Append option in a parsing rule is ignored for pseudo-fields because of the special processing these fields already do. The special cases are the pseudo-fields for credit card number, date, and name. These allow appending because there are so many possible formats the credit card information might be sent.

Customer Pseudo-fields:

- **First and Last Name** -- Use when the whole name is in one string, like "John Smith". Assumes the last word is the Last Name, and the rest is First Name(s).
- **Last, First Name** -- Use when the name is in one string with the last name first. If a comma is not found, the first word is assumed to be the Last Name and the rest is First Name(s).
- **City, State, Zip** -- Use when the string is the whole bottom address line with all three of these. It will put them into the separate data fields.

Reservation Pseudo-fields:

- **Departure Date (Last + 1)** -- Use when the departure or check-out date is present instead of the Last Night.
- **Number of Nights** -- Use when there is no last night or departure date present, just the number of nights. Note that a rule to extract the First Night must appear prior to this one.
- **Number of sites requested** -- If the request could be for more than one site, set this field so it knows how many linked reservations must be created.
- **Unit ID from E-mail requests** -- Use for E-mail requests if the request contains a special ID, not the same as a site number (see Online Setup -- Site Data Fields).
- **Unit Type from E-mail requests** -- Use for E-mail requests if the request contains a unit type, not the same as a site type (see Online Setup -- Site Data Fields).
- **Unit ID from Reservation Friend** -- Use for Reservation Friend requests for the site name sent in their reservation data (see Online Setup -- Site Data Fields).
- **Unit ID from iCal** -- Use for iCal file importing to look up the site by the "iCal ID" field (see Online Setup -- Site Data Fields).
- **Import filename from iCal** -- Use for iCal importing to look up file by the File Expression from the iCal Profile (see Online Setup -- Site Data Fields).
- **Credit Card # (Guarantee)** -- To extract the credit card number for the guarantee information (these are pseudo-fields because the credit card info is stored in the Guarantee Info fields in a special format, not as separate fields).
- **Credit Card Name (Guarantee)** -- For the credit card name.
- **Credit Card Exp Date (Guarantee)** -- For the credit card expiration date as one string. Will accept several formats, like 0705, 7/05, 07/05, 7/31/05, or 7/31/2005.
- **Credit Card Exp Month (Guarantee)** -- For just the month part of the expiration date, if it's a separate field.
- **Credit Card Exp Year (Guarantee)** -- For just the expiration year as a separate field.
- **Credit Card CVV (Guarantee)** -- For the CVV/CVC2 code on the credit card.

Transaction Pseudo-fields:

- **Credit Card #** -- (same as for reservation fields above).
- **Credit Card Name** -- (same as for reservation fields above).
- **Credit Card Exp Date** -- (same as for reservation fields above).
- **Credit Card Exp Month** -- (same as for reservation fields above).
- **Credit Card Exp Year** -- (same as for reservation fields above).
- **Credit Card CVV** -- (same as for reservation fields above).

Parsing Set Example

The best way to learn how to set up parsing rules is to do an example. A detailed step-by-step example of a parsing set is available in the program's Help. Under Help / Help Topics, select the Index and look for "Parsing Sets, Example".

Web form example with parsing rules

In addition to the step by step example, there's a complete example of an HTML web form that you could use on your web site, along with the Parsing Rules needed to extract the data from the E-mail you would get when someone fills in the form. This assumes that your web provider has some kind of form script that you can use to handle the HTML "<form>" processing. Of course this is still intended for your web site designer since it will probably require a some modifications for your specific application, but perhaps it will minimize the time needed to set it up.

You can get the links to download the examples through the program's Help. Under Help / Help Topics, select the Index and look for "Web form, Examples".

iCal File Support

Overview

iCal, or iCalendar, is a common file format that is used in many places to share information about calendar events -- originally used for appointments, meetings, etc, it has also become commonly used in the hospitality industry for reservations.

Campground Master supports iCal in 3 different ways, each of which you may use independently as desired:

1. An iCal file can be automatically attached to each E-mail confirmation you send out. If the recipient uses a compatible E-mail service with a calendar app (e.g. Gmail), they will be able to add the reservation to their calendar with a couple clicks (or in some cases it may be added automatically).
2. You can export iCal files containing the information needed to show "availability" on some online reservation services.
3. You can import iCal files from some online services to assist in adding those reservations into Campground Master.

Please note that the iCal Import and Export options are not fully automatic and are not a good substitute for a true 2-way real-time automatic integration like Hercules. These are simply alternatives for cases where Hercules will not work for you (e.g. outside North America), or would be an overkill (e.g. if you only rent out a few units).

The following sections explain the basic procedures for setting up and using the 3 different types of iCal functionality. Following those are more details for each function.

Important: While we've attempted to make these functions as easy and accessible as possible for the non-technical user, all of this is considered an Advanced Customization function due to the flexible and ever-changing nature of iCal support by various services. Therefore normal technical support will not be able to assist with setting it up or solving issues except with basic functionality questions. You should consult your own computer and web site expert for help with the details required to configure things like the Profiles and Parsing Sets if you're trying to integrate services beyond the examples we provide. Any assistance you ask us to provide will incur customization fees.

Attaching iCal files to E-mail confirmations

iCal files can be automatically attached to each E-mail confirmation you send out (or only certain E-mail confirmation forms, as desired). If the recipient uses a compatible E-mail service with a calendar app (e.g. GMail), they will be able to add the reservation to their calendar with a couple clicks (or in some cases it may be added automatically).

Of course this assumes you also have Campground Master configured for sending E-mail confirmations. See that section for details if necessary.

WARNING -- Attaching an iCal file to the E-mail will sometimes result in the recipient ONLY seeing an "Event card" from the iCal file and not the rest of the E-mail text. This depends on the E-mail reader they're using, and sometimes the contents on the iCal file. Use this with caution, and perhaps as a completely separate E-mail from the normal confirmation.

Setting Up for Attaching iCal files to E-mail

There are only two things required for this functionality:

- Create an iCal Profile with the Profile Type "Attach iCal File to Confirmation E-mail".
- Select the "Attach iCal file" option in the Form Definition of any "E-mail" type Form you want to have the file attached to (for instance, you probably don't want it attached to E-mail Invoices, etc that may be sent to Monthly residents).

To create the Profile for this functionality, only a few simple steps are needed:

1. Go to Maintenance / Online Reservations / Other Online Interfaces / iCal Profiles.
2. Click "Add profile".
3. Enter a Description (whatever you like).
4. Select the Profile Type ("Attach iCal File to Confirmation E-mail")
5. Make sure "Enabled" is checked.
6. Click the "Use Default" button for each of the Expressions (file name, UID, SUMMARY, LOCATION, and DESCRIPTION).
7. Click OK.

Optionally you could have multiple profiles (for different Site Types or dates, for instance), however that would be an advanced and probably unusual situation and is not necessary for basic operation. Refer to the other sections on Profiles for details.

To select the "Attach iCal file" option for the desired E-mail forms:

1. Go to Maintenance / Advanced Customizations / Forms.
2. Select a Form with the "E-mail" Form Type that you want to attach iCal files to, and click Edit form definition.
3. Check the box "Attach iCal file" (in the upper left).
4. Click Save.
5. Repeat steps 2-5 for each form desired, then Close.

Nothing further is needed -- now the iCal file will be created and attached to each E-mail confirmation (or other E-mail Forms selected) automatically. You can also attach any other files as usual.

A couple notes for Linked reservations:

For *Non-synchronized* reservations, they will be handled separately just as all transactions and receipts would be. While the E-mail itself may list the linked reservations, iCal files for non-synchronized reservations will not be included -- you would need to go into New/Edit Transactions for each linked reservation and Send E-mail Form to send separate confirmations for each one.

For *Sub-member* and *Synchronized* reservations, it will attach an iCal file for each one (so the E-mail will have multiple iCal attachments). This is necessary because the guest's calendar may not recognize multiple entries in one iCal file. When they receive the E-mail, they may need to add each one to their calendar (depending on their E-mail/calendar software).

Setting up for Export to iCal files

If you're interested in setting up Campground Master to export to "iCalendar" files, aka "iCal" files, the following areas need to be addressed. (See the related sections for details.)

Note that this refers only to making iCal files available to other services to show your availability -- this setup is not necessary for attaching iCal files to E-mail confirmations to add the reservation to the individual guest's calendar.

- Enable iCal exporting under Online Connections & Options / iCal.
- If you want Campground Master to also upload the files, make sure you have FTP access to your web site to upload the files once they're generated, and set up the FTP connection settings for uploading the iCal files.
- Enable the Site data fields "Site_Online_iCal_Ex", "Site_Online_iCal_Unavailable" and/or "Site_Online_iCal_Release_Days" if you want to limit online or offline availability of sites.
- Find out the details required for the iCal formatting from any services you plan to use (e.g. AirBnB). This may include filename requirements as well as field formats for the Summary, UID, Location and Description fields and also matching up unit names with your Sites in Campground Master. See the Profiles information for more details.
- Enable any Site data fields needed to support special formatting requirements above (e.g. filename, site name, summary, etc). If you're exporting for more than one service, this may require adding additional custom fields.
- Create one or more iCal Profiles to be used when generating the files.
- Fill in the Site data fields above with the appropriate values.

Note that this functionality is often used in conjunction with the iCal Import functionality, so you may also want to see that section (Importing iCal Files).

Exporting to iCal Files

Once you have it set up to Export iCal files, there are 2 ways you can initiate the exporting and uploading (if enabled) of the files:

- Go to File / Export / Export to iCalendar files, and click the button to Export or Export and Upload.

- If you're also configured for Importing iCal files, you can go to Reservations / Retrieve Online Reservations, select "iCal files" for the Source, and click the [Export iCal files](#) (or [Upload iCal files](#)) button.

This will go through all iCal Profiles with the "Export" type, and create files for all applicable sites as defined by the filtering in each Profile. Each iCal file will contain "events" for the reservations and possibly other unavailable dates for that site, again following the criteria in the Profile.

If you only use the Export option and don't have Campground Master upload them, then it's up to you to do something with the iCal files generated (e.g. using your web site management tools to upload them, or send them to someone for further handling).

If you use the Upload option, then they will all be uploaded to your web site, as directed by the FTP settings in the iCal setup, and to the directory as defined in the Profile. From there it's up to your online reservation service to access the files (for instance, your service may grab the files every 15 minutes to update availability).

Again, be aware that this is not real-time and cannot prevent double-booking of those sites. It's up to you to manage the exporting/uploading in a timely manner, importing online bookings into Campground Master regularly, and to limit local/offline booking of sites to minimize issues.

Setting up for Import from iCal files

If you're interested in setting up Campground Master to import from "iCalendar" files, aka "iCal" files, the following areas need to be addressed. (See the related sections for details.)

- Enable iCal importing under Online Connections & Options / iCal.
- Find out the details for the iCal formatting from any services you plan to use (e.g. AirBnB). This may include filename requirements as well as field formats for the Summary, UID, Location and Description fields and also matching up unit names with your Sites in Campground Master. See the Profiles information for more details.
- Enable any Site data fields needed for specifying the details in the profiles, specifically "Site_Online_iCal_Import_File". If you're importing from more than one service, this may require adding additional custom fields.
- Create one or more iCal Profiles to be used when importing the files.
- Create one or more Parsing Sets with the "iCal format" Parsing Set Type, to be used when importing the files.
- Fill in the Site data fields above with the appropriate values.

Note that this functionality is often used in conjunction with the iCal Export functionality, so you may also want to see that section (Exporting iCal Files).

Importing iCal Files

Once you have it set up for Importing from iCal files, you can import the reservations from iCal using Reservations / Retrieve Online Reservations. Once the "iCal files" Source is selected, click "[Retrieve Online Requests](#)" to download the iCal files.

This will go through all iCal Profiles with the "Import" type, and download the files for the applicable sites as defined in the Profile definition. Each iCal file will contain "events" for the reservations for that site, which will be Parsed according to your defined Parsing Sets, and the requests will be listed and ready to process.

Refer to the [Retrieve Online Reservations](#) section for further details on using this function to process the requests.

Note that Campground Master will combine all iCal files into one temporary local file for processing ("ical.txt"), which will be saved in the Windows "temp folder" -- if you leave this function and re-enter it, any previously reservations will be processed from the local file and shown again without doing the download.

Important: Be aware that if you use "Download" again, it will **replace** the local file with the newly downloaded iCal files -- any previously unprocessed reservations could be lost if they are no longer available in the downloaded files.

Setup iCal Profiles

Start setting up iCal Profiles by opening the iCal Profile Setup dialog ([Maintenance / Online Reservations / Other Online Interfaces / iCal Profiles](#)). This will list any already defined (if there are any), with their Description, Profile Type, whether it's Enabled, and any Notes. From here you can add or edit profiles, delete obsolete profiles, and move profiles in the list.

You can also [Print](#) or [Export](#) the shown list at any time.

Adding or Editing Profiles

Note that the information shown for the Profiles in the list are coming from the Profile definitions -- they cannot be changed directly in the list. You need to [Edit](#) the profile to change it.

The basic procedure for defining a Profile is to click [Add profile](#), and then enter the details of the profile, along with the applicable sites, dates, etc that determine its function. [Insert](#) is the same as [Add](#), except that the profile will be inserted in the list at the current selection point, rather than added to the end of the list. You can edit any of the existing profiles by clicking on the profile in the list and selecting [Edit profile](#), or you can double-click on the profile in the list.

Warning -- Once a profile is edited or deleted, there is no way to Cancel the operation -- the changes are permanent once you leave the Edit profile dialog and come back to the Setup iCal Profiles dialog.

You can [Move](#), [Delete](#), or [Copy](#) one or more profiles by selecting the profiles in the list (Ctrl-click or Shift-click will select multiple profiles), and then click the appropriate button. Copying profiles is handy if you have profiles that are similar but have slight variations, such as sites or unavailable dates.

Profile Order

The order of Profiles does not matter to the functionality except for one case -- if attaching iCal files to E-mail confirmations, it will use the first profile (with the "Attach" type) that it finds in the list that's applicable to the Site. Other than that, you can put them in any order you like.

Importing and Exporting Profiles

These functions allow copying profiles from one database to another (or between computers). This is used if you have your software provider do the setup on another system and then need to import that setup to the working database on your computer. The Import function will **only** work with files exported using the Export Profiles function here. It cannot import profiles from a user-created file.

The Export function creates a text (CSV) file in a special format that the Import function can read. This can include one or more definitions (select the entry or entries to export before clicking the Export button). To complete the export, select the location (Save in) and the file name for the exported file with the "Export" file dialog is shown.

The Import function is simply the reverse of Export -- select the CSV file containing the exported profiles, and Open it to import the profiles into your database.

Edit iCal Profile

When you select New, Insert, or Edit from Profiles Setup, the Edit Profile Definition dialog will appear. This is where you define all of the details of the profile.

Make sure that the desired Profile Type is selected (this can be changed any time), and enter a Description. Then continue to the other options as applicable.

Description

The Description is only shown in the Setup Profiles list, so you should make it simple but also descriptive enough for easy recognition.

Enabled

Check this box to make it active -- otherwise it's ignored by the various iCal export and import functionality.

Profile Type

There 3 different Profile Types to choose from:

- Export to iCal file & upload
- Import form iCal file
- Attach iCal file to Confirmation E-mail

Depending on the Profile Type selected, various additional parameters will appear that must be filled in....

Local working folder

Normally you will leave this blank. It will use the same folder as the database to create iCal files as needed. If you have specific requirements, e.g. if Exporting iCal files and want them to go to a certain location for manual uploading, then you can select that folder here with the Browse button (or enter it manually). Also, if you're importing from multiple services and there's a chance that they might use the same file name, then you should specify a different local working folder in each service's Profile.

Use a separate file for each site

Most online reservation services will expect a separate file for each Site / Unit, so this box should be checked unless they can handle all Sites in one iCal file. Of course this selection will also affect the expression for the file name, and probably expressions for some other fields as well.

Expression for file name

This tells Campground Master how to create the iCal file name for each site (or single file if not using a separate one for each site). In many cases it will be sufficient to click the "Use Default" button to have it insert the default expression. Note that iCal files should always end in ".ics" to give them the standard "ics" file extension.

If not using a separate file for each site, the default will simply be "iCal_export.ics" or "iCal_import.ics" (note that the quotes are necessary since it's an Expression, so don't remove those if you change the file name). Otherwise the default will use the site information as below:

For Exporting iCal files:

The default in this case will use the file name you specified in the Site Data Field "Site_Online_iCal_Export_File", or if that's empty it will create a generic one with "iCal_" followed by the site's Abbreviation field. If the online service(s) you use allow you to specify the iCal upload file for each site, then this may be sufficient. You will of course have to supply the resulting file names to your online service for uploading (as part of the complete URL where they can be retrieved from, which also involves your FTP setup). If different services need different files (e.g. if you have multiple Profile definitions for separate services), then you will also need to make sure they create separate files, and will therefore need to have different Expressions for the file name.

For Importing iCal files:

The default in this case will simply be the Site Data Field "Site_Online_iCal_Import_File", so that field will have to be filled in for each site with the file name you're given by the service. If that field is empty for a site, then an iCal file cannot be imported for the site. Of course you can modify the expression to use any filename you want, or get the name from a different Site field (which would be necessary if you're importing from more than one service, and of course will need to have a different Profile for each service). Also see the Download URL, which determines where the file is downloaded from.

Also note that the resulting file name here (for each site) can be important for identifying the site in the Parsing Set, for importing the reservations. It will be matched up to the site if you use the pseudo-field "Import Filename from iCal" in a parsing rule to identify the site.

Upload to web site (FTP)?

Check this box for Export profiles if you want Campground Master to be able to upload the exported files. Of course the FTP setup will need to be done, under Connections & Options / iCal.

Download URL

This must be set for Import profiles, and should be the full URL of the download path except for the filename itself (which will come from the "Expression for file name").

Expressions to use for creating the fields of the iCal file...

The following expressions are used to create the iCal field information when exporting iCal files (or attaching to E-mail confirmations). The specifics will depend on each online service you use. You can try the "Use Default" button on each one and see if that works, however each service may have specific requirements. In any case the "Use Default" is a good starting point.

For explanations of what these fields are and what can be used, please refer to iCal specifications on the web or get details from your online reservation provider. The details are much too complicated to cover here, and our technical support cannot explain it to you beyond what examples and defaults are available here.

UID field

This field is usually not important for exporting, except that some services can use it to identify reservations that came from them for conflict resolution. So the default will insert the "Resv_Online_Request_ID" field, which should be the UID provided by the originating service.

SUMMARY field

While this is typically used for a description of the Site/unit, this might be used for other things. The default will insert the "Site_Online_iCal_Summary" field or the "Site_Online_iCal_ID" if one of them exists, otherwise will simply insert the Site Name and possibly the Site Type.

LOCATION field

While this is typically used for the name of the property, this might be used for other things. The default will insert the "Site_Online_iCal_Location" field if it exists, otherwise will simply insert the Park Name.

DESCRIPTION field

This is optional and usually ignored when Exporting/uploading to online services, but the default will insert some basic information about the reservation, or simply "Unavailable" if the site is otherwise not available.

However when Attaching the iCal file to Confirmation E-mails, this is particularly important -- the guest's calendar program may show the information included here, so it will include the park name, site name (or type), dates, guest name, phone, E-mail address, and number of adults and children.

Custom fields

This is usually not used (the default will be blank). It's a very advanced function, used only if an online service requires special fields in addition to those covered above.

Important: While all other fields will automatically handle "escaping" characters like comma and colon for proper iCal formatting, the Custom field will not do automatic escaping (it wouldn't know when characters are required as-is and which need escaped). Therefore you will need to be very careful about the creation of any custom field expressions! If you need to add more than one header line, then use the "newline" escape (\n) between lines.

Custom headers

This is usually not used (the default will be blank). It's a very advanced function, used only if an online service requires special tags in the header in addition to those covered above. Anything added here will be inserted in the iCal file before the Events (VEVENT sections). The Site will be in context if it's a file for an individual site, but not if it's exporting a single file for all sites.

If you need to add more than one header line, then use the "newline" escape (\n) between lines. For example to add a METHOD:PUBLISH and a CAMPSITE line to the header, you can use:

```
"METHOD:PUBLISH\nCAMPSITE:" + FieldText(Site(),"Site_Name")
```

Go to Site Data Fields / Go to Parsing Sets Setup

These buttons are simply a convenient way to get to the respective functions, instead of getting out of the Profile editing and going through the menus again.

Maximum future days to export

This is very important, since days past this will automatically be considered available for online reservations! In general, this should be as large as needed to include all future reservations you might have, however there are some practical reasons to limit it. In particular, since "unavailable" dates are also exported, not just reservations, then a larger number could result in a larger iCal file just to accommodate those. Therefore if the service you're exporting to will only take reservations up to a year in advance, for instance, then there's no reason to make it much larger than 366 days. (If you're only uploading occasionally, like once per week, then be sure to add enough extra days to cover the gaps.)

"Import iCal only for..." (or "Create iCal only for...") Filtering

The rest of the dialog entries are used to "qualify" a profile. This determines whether the profile definition applies to any given site, so it's important to get this set up properly.

Note that iCal files can only be filtered by the Site, to determine whether the iCal file is created or not. You cannot selectively include or exclude reservations from the iCal file itself, with one exception -- the box "Site is considered unavailable if there's an Owner reservation" can be checked or unchecked depending on whether you want Owner-type reservation dates included as unavailable (see below).

Site Types, Site Classes, or Sites

If this profile only applies to certain Site Types, click the Site Types button and select the applicable types from the list that appears. If no site type is selected, the profile will apply to reservations of any site type (assuming other filters don't exclude it). If you select one or more site types here, then that profile will only apply when a reservation is for one of those site types.

Likewise, you can have a profile apply to specific Site Classes, using the Site Classes button, or even one or more specific sites using the Sites button. However you don't need to set all three (types, classes, and sites) -- usually only one of these selections is enough to sufficiently qualify the profile. For instance if you select "Normal RV" for the Site Type, there's no need to select "RV's" for the site class because it's redundant -- all "Normal RV" sites will have an "RV's" class anyway, so there's no need to make the profile check this too.

Advanced Condition Expression...

If the profile can't be properly qualified using the other Applies-if conditions, date selections, etc, then you can use Expressions to create a condition as complex as needed. Note that this involves the Advanced Customizations functionality and is only recommended for very technical users, so refer to that section for more detailed information.

If a Condition Expression is entered here, it must be satisfied (result in True) in addition to all other conditions in the profile definition in order for the profile to be used. Thus you can use the other Applies-if conditions to handle the simple stuff, and use the expression to only do the filtering that can't be otherwise handled by the profile definition.

The expression will have **ThisSite()** context which will be the specific site being checked.

Site is considered unavailable if there's an Owner reservation

If this box is checked, Owner-type reservations will block the site's availability. If you allow sub-leasing of Owner sites when not otherwise occupied, then leave this unchecked to consider the site available for other reservations.

Special dates to show Not Available

You can define the dates to specifically show as "unavailable" for the sites exported in the iCal file(s) for this profile. Defining dates for a Profile definition is just like defining dates that a Site is available or Rates are applicable (see Edit Site Details or Edit Rate Definition).

Notes

The Notes field is just for your own notes, perhaps an explanation of why a profile is set up the way it is. The notes can be any length.

Sample iCal Parsing Sets

Parsing Sets are covered in depth elsewhere, and you will likely need to be able to create your own for iCal files for various services. However convenience we've created a couple examples that may work for selected services, and more may be available from us later that aren't mentioned here.

To import the sample(s):

1. Go to Maintenance / Online Reservations / Other Online Interfaces / [Parsing Sets](#).
2. Select "iCal format" for the [Parsing Set Type](#).
3. Click the Import [Import set\(s\)](#) button, and you'll get a typical Windows file-open dialog labeled "Import Parsing Sets".
4. You need to locate the Samples folder, which is typically C:\Program Files (x86)\Campground Master\Samples (most likely you just need to double-click the "Samples" folder to get there, but you may have to navigate to the location first using the "Look In" drop down at the top).
5. Now select the appropriate file starting with "Sample Parsing Set", for instance "Sample Parsing Set - AirBnB", and click Open. You'll see one or more items added to the list. When done importing, click Close.

Note that these are examples that may require additional modification, depending on your requirements and current specifications of the provider (which are subject to change).

Here are some specific tips here for iCal parsing that are not covered in the general Parsing section (which was originally created and written for parsing E-mails from web form submissions).

- Make sure you select "iCal format" for the Parsing Set Type.
- When Campground Master receives an iCal file, it will automatically add the following "fields" to it to aid in parsing:

DOWNLOADURL: -- this is the complete URL used to download the file

SITEDOWNLOADFILE: -- this is the filename part of the URL

CMSITENAME: -- this is the Site Name that Campground Master downloading the file for (assuming a separate file for each site)

You can use one or more of these fields in the Parsing Rules to identify the site. Using Parsing from CMSITENAME directly into the Reservation / Site Name field is the most efficient, but might not work in some cases. You can also use SITEDOWNLOADFILE in a rule to parse into the pseudo-field "Import Filename from iCal", which will automatically select the site by matching up the file name with the results of the "Expression for file name" in the Profiles -- however that can be slow since it has to evaluate the expression for every site in every profile until it finds a match.

However if the service puts reservations for all sites into a single iCal file, then you will need to find a way to match up the site from one of the other fields, for instance the SUMMARY or LOCATION field. Unless it's using the exact site name that Campground Master uses, this would require using the Site's "iCal ID" field (Site_Online_iCal_ID) to put the expected name of the site from the online provider, and a parsing rule with the pseudo-field "Unit ID from iCal" which will look it up from that Site field.

- For the start and end dates, parse from "DTSTART;VALUE=DATE:" into the First Night field, and from "DTEND;VALUE=DATE:" into the "Departure date" pseudo-field (since it's the Last Night + 1).
- Any customer information you'll probably need to get from sub-fields in the DESCRIPTION field, and will depend on how the online service formats it.

Aside from those notes, parsing from an iCal file is the same as parsing from E-mails. You'll need to know the details of the iCal file format, etc.

Retrieving Online Reservations

Overview

To retrieve online reservations and update online availability information, go to Reservations / Retrieve Online Reservations. Of course you will first need to have everything set up appropriately first -- refer to Maintenance / Online Reservations for complete details.

Retrieving Hercules 2-way Requests

If using the Hercules 2-way integration, it's generally not necessary to retrieve requests here unless the Incoming operations mode is "Manual request only". In automatic modes, any reservations available should already be downloaded and listed here. In "Fully Automatic" mode, there should not be any here unless there were errors that caused them to not be imported. In that case, any reservations that could not be imported automatically will be shown here, even without doing a "Retrieve" operation..

To Retrieve any pending requests:

Retrieving and processing online requests generally requires a few steps:

1. Select the desired Source (only sources you've enabled will be shown, and thus there may only be one source option).
2. Retrieve Online Requests -- This will go online to retrieve any new requests from the selected source. All requests retrieved will be displayed in the list.
3. View / Process Request Details -- You will need to open each request, perform any necessary functions like selecting a site, entering the deposit, etc., and then Save it.
4. Upload Site Availability -- Whether or not there are any new requests, you can upload the current availability information to the Internet.

If you're set up for more than one source (e.g. E-mail and Reservation Friend), you can repeat the steps above for each source.

Note that the operator access level required to retrieve and process requests is Manager by default, but it can be modified through Maintenance / Park Setup / Access Levels.

Miscellaneous Functions

The main processing functions listed above are described in sections following this one, but there are a few other functions available on the main Online Reservation Requests dialog.

Paste & Process Request Text (does not apply to Hercules 2-way)

This function can be used to manually process requests that can't be retrieved directly, or for testing. For instance, if the only E-mail account you have does not support POP3, then E-mail requests can't be retrieved automatically. You will need to copy the request from the E-mail window, then use this function to paste it into a processing window. The processing will proceed just as if it was retrieved directly, e.g. the parsing rules will be applied to extract the data from the text.

Note that you may need to get the complete "source" text and paste it, including the E-mail header information, for requests to parse E-mail requests correctly. The "Message-ID" part of the header is used as the default Online Request ID, so unless your parsing rules extract another value for this unique ID, the E-mail header must be included. For America Online, you need to use the "View Message Source" function to get the complete raw message text with the header (this may be in various places depending on the AOL version, but it's commonly under the "Actions" menu when viewing a message).

Re-process Downloaded Requests (does not apply to Hercules 2-way)

When requests are downloaded from the source, they are placed in a local file (this helps avoid accidental deletion, since they may be removed from the source as soon as they're retrieved). When you use this re-process function, it will read the file with the previously retrieved data and parse the requests already in it, instead of going online to get new requests. Since all downloaded requests are actually appended to any previous requests in the file, you could potentially accumulate requests indefinitely into the same file. (See the Delete function below to clear the file.)

Note: For iCal files, the local file is re-created each time you download, and re-processed as soon as you re-enter Retrieve Online Reservations, so this function is not necessary.

Re-processing requests won't be necessary under normal conditions, but it's likely to come in very handy while getting started and tweaking your setup. You can simply use this function to read requests from the file, which will of course be faster than downloading them, and it will also grab previous requests that may have already been deleted from the server. Don't worry about creating duplicate reservations, though -- once a request is processed and Saved, its Online ID is stored so can't be processed again. Any of these prior requests that you've saved will be indicated as such in the list.

Delete all Downloaded Requests (does not apply to Hercules 2-way)

Once you're sure that all downloaded requests have been processed (Saved or Ignored as appropriate), you may want to delete the downloaded requests. While deleting them is technically not necessary, this will "clear the clutter" in the temporary files used for storing the downloaded requests. It will also speed up processing (or at least re-processing) of future requests. Of course it will not delete any Saved reservations, since those are already recorded in your database.

Note that this is completely separate from deleting requests from the server (e.g. the POP3 mailbox). You will generally want to have Campground Master delete them from the server automatically each time they're retrieved to avoid excess accumulation there. See the Online Setup section for the option to delete requests from the server.

Downloading Requests

When someone makes a request from your web site or other online service, it just sits on a web server or in an E-mail mailbox waiting to be picked up, or "downloaded". You should perform this function regularly (preferably a few times per day), for instance anytime you check E-mail, so the requests can be processed and confirmed promptly.

The exception to this is the Hercules 2-way integration, when configured for Automatic mode -- in that case reservations are downloaded and possibly processed automatically, so this function is only needed to resolve synchronization issues.

To check for and retrieve any new online reservation requests, go to [Reservations / Retrieve Online Reservations](#). Select the Source if necessary, then click the [Retrieve Online Requests](#) button. Campground Master will connect to the Internet (if necessary), and retrieve any waiting requests. Depending on the setup options, it may also automatically delete the retrieved requests from the server to keep it tidy (this also minimizes the time needed to retrieve requests the next time).

If any new requests are retrieved, they will be displayed in the list. Note that if it retrieves a request that has already been processed, then the status of that request will be shown as "Saved" so you don't process it as a duplicate. Of course if it's automatically deleting requests from the server when it retrieves them, then there shouldn't be any such duplicates to show.

Retrieving Hercules 2-way Requests

This is generally not necessary unless the Incoming operations mode is "Manual request only". In automatic modes, any reservations available should already be downloaded and listed here. Of course in "Fully Automatic" mode, there should not be any here unless there were errors that caused them to not be imported.

When this is done, it simply checks for any new online reservations available through the 2-way interface.

Retrieving E-mail Requests

When "E-mail" is selected as the Source, it will check the POP3 mailbox (as designated in the setup) for any new E-mail messages. It will download all E-mail messages present, and attempt to parse each one to see if it's a request. If there are some messages that aren't recognized as valid requests, they will still be included in the displayed list of requests. The status of unrecognized messages will be set to "Ignored" and the Notes column will show the message subject (so you can see if it's just a junk message). If you see an ignored message that looks like it should be a valid request, you can use the function at the bottom to Edit Original Text, and try to salvage it by editing the text.

All E-mail messages retrieved are also saved in a temporary file "email.txt", located in the folder you designate in the online reservations setup. This can be viewed with a text editor like Notepad or Wordpad if desired. You can use the Re-process Downloaded Requests function to read this file and scan all E-mails again if needed (for instance if you're still testing your parsing rules). Once you're sure that you don't need the saved E-mails any more, use the Delete all Downloaded Requests function to clear this temporary file.

By the way, there is no danger of getting a virus or other malicious E-mail problem, since Campground Master simply scans the text of the message -- it won't run code in an E-mail, and any attachments to the E-mail are completely ignored (actually the attachments are retrieved as text, so they are harmless).

As mentioned in the online setup section, you may want to have all requests go to a POP3 mailbox separate from your normal E-mail. The main problem with sharing the mailbox is that when you retrieve your other E-mail, you would be removing requests from that mailbox so they can't be retrieved and processed automatically here.

If it's not feasible for you to use a separate POP3 mailbox for requests, then if there are any requests that didn't get picked up the last time you used the Retrieve function, you will need to copy the request text from your other E-mail program and use the Paste & Process function here. Therefore it would be a good idea to do the Retrieve just before you check your other E-mail so that any requests waiting in your mailbox are retrieved automatically. Also make very sure that the "Delete messages from server..." option is **not** enabled in the Online Connections setup for E-mail requests if you're sharing a mailbox.

Retrieving iCal files

When "iCal file" is selected as the Source, it will download all iCal files as defined by the iCal Profiles and process them. See the section *Importing iCal Files* for more details.

Processing Requests

Once any new requests have been retrieved, the next step is to "process" them. This is mostly just a matter of looking at the request details to make sure everything is in order, selecting a site if needed, and then save them so they become a real reservation in Campground Master (also creating the appropriate customer record and deposit transactions as needed).

All "new" requests will be shown in the list in the Online Reservation Requests dialog. A "new" request is any request just Downloaded, or added with the Paste & Process function, or Re-processed Downloaded Requests.

The Status column will show one of the following values:

Unprocessed -- It's a new request, not processed and saved as a real reservation yet.

Saved -- It has been processed and saved as a real reservation.

Ignored -- It has been viewed and ignored for now, during this session. This may include retrieved E-mail messages that were not recognized as valid requests.

Error -- The request could not be parsed using the defined parsing rules (either an error in the rule definition or a problem with the request data). If you hold the mouse cursor over that line in the list, the error details will be shown. You should check any of these to see whether they can be salvaged using the Edit Original Text function.

The Notes column would normally show any reservation notes extracted from the request, but if a request has an error or if it's ignored due to missing information, then the Notes column will include the Subject of the E-mail message. This will help you determine if it needs further attention.

Processing a Request

You can view a request's details and process it by selecting the request in the list and clicking the View / Process selected request button at the bottom. As a shortcut, you can also just double-click the request in the list. If it's a Saved request, this will take you to Reservation Details since it's already a real reservation. Otherwise it will take you to the Online Request Details dialog, where you will process the request and make it a real reservation. Once you've saved it there, it will be designated as such on the list and you can continue with the next one.

Once all new requests have been suitably processed by either saving them or ignoring them, you can proceed to uploading the new availability data and/or deleting all downloaded requests to clean things up.

Note that you can also attempt to process requests that have an "Error" or "Ignored" status. Of course an error may still prevent it from being correctly processed, but you can at least see what fields were retrieved. If a request was previously Ignored, you can use View / Process to essentially undo the ignored status and complete the processing for it.

Editing a Request's Original Text

There may be times when a request can't be parsed or processed correctly due to a problem with the original text (e.g. the E-mail message may not be formatted as expected, causing it not to be parsed correctly). As long as the request has not yet been Saved as a real reservation, you can view the complete retrieved request in raw text format by selecting the request and clicking the Edit Original Text of selected request button. This will show the raw text and you can do any editing necessary. When you click Save, it will attempt to parse the request again. Note that the original request will be deleted from the list, and the newly parsed request will be added to the bottom of the list.

Link to an Existing Reservation

This is primarily used for the Hercules 2-way interface to aid in initial synchronizing, for online reservations that were also entered manually in Campground Master so they don't have the Online Order ID to allow synchronization.

Select the online reservation from the list, click this button, and then use the Find Reservation dialog that opens to locate the existing Campground Master reservation that matches the online request. Tip -- you may

want to move the Find dialog around so you can see the online reservation information in the grid to help match up the customer, site and dates to make sure you have the right one.

Once you locate the desired local one and click "Use" in Find Reservation, the local one will be updated with the Online Order ID so they will stay synchronized. No other information from the online reservation is saved, since it should already be in the local reservation.

Ignoring a Request

You can designate a request as "Ignored" by selecting the request in the list and clicking the Ignore selected request button at the bottom. This is usually done for requests that you decide not to save, like junk requests. Actually it does nothing except set the status in the list to "Ignored", mostly for your own convenience so you know you didn't skip it by accident, in case you have a lot of requests to process.

Note that ignored requests are not saved in the database at all -- once you close this dialog window, it will be gone -- except that it will still be in the temporary download file as long as you don't click Delete all Downloaded Requests. Thus you could ignore it for now and use the Re-process function later to retrieve it -- at which time it will show "Unprocessed" again (the Ignored status is temporary, it's not remembered). If you just need more information from the customer and may want to keep it later, it would be better to save it as an Inquiry instead of ignoring it (this can be done through the Online Request Details dialog).

Online Request Details

The Online Request Details dialog is invoked through Online Reservation Requests, by selecting an unprocessed request in the list and clicking the View / Process selected request button below the list. As a shortcut, you can also just double-click the request in the list.

Request Fields and Values

The request will be shown in a simple table of Fields and Values. Each field will be shown as extracted from the request data, using the Parsing Rules you've defined. Note that the fields are shown in the order that they were extracted, which is generally the order that they appear in the parsing rules. Only fields that were successfully extracted will be shown. Thus if a parsing rule is defined to set a field like "50 Amp" if it's requested, but it wasn't requested, then that field may not be shown in the list.

Many fields will show both the record type (table name) and field name, for instance "Reservations : First Night". In some cases there may be an index number after the record type, for instance if more than one transaction is to be created for the reservation then you might see "Transactions[+1] : Type".

Some "fields" aren't necessarily data fields, for instance a "Unit Type" may be shown that specifies the type of site requested. This is a temporary value that's used when selecting a site, but will not be saved with the reservation. Another example of a temporary value would be "Number of sites requested" -- this is used to determine how many linked reservations will actually need to be created from this request.

Editing Fields

If you see obvious mistakes in a field value, you can edit the value before saving the request. Just click on the value twice (once to highlight it and again to enter editing mode). Some values may be drop-down lists instead of editable text, just as they would be on other dialogs. For instance the Rig Type would be a drop-down pick list.

Only true data fields can be edited -- temporary values as mentioned above and other pseudo-fields cannot be edited.

Close (skip for now)

This will simply close this window and go back to the list of requests, without processing (saving) this request.

Note that any editing done to field values *will* be saved as long as you're still processing the list of requests, so the changes will be remembered if you come back here to View / Process the request. However any changes not saved as a real reservation will be lost if you close all the way out of the Retrieve Online Reservations dialog.

Selecting a Site

Before saving the request, you will usually want to assign a site (or sites) for the reservation using the **Select a Site** button. This function will let you select a site using the same "Assign or Change Site" dialog used elsewhere in Campground Master. You may notice a couple minor differences, however. Since this is not a real reservation yet, everything in the site selection dialog will be disabled except for the controls necessary to select a site. For instance, you can't use "Guarantee", or view customer details. Also note that any preferences selected or changed here will not show up when you return to the request details.

If the request specified a particular site already (either by specific site name or because only one site matches the online site data field designation of ID/name/class/etc.) , then it will be assigned automatically and you don't have to select one at all. However you could change the site if needed -- it will ask if you want to start over and select a new site if a site has already been selected.

If you have set up Site data fields like "Site_Online_Email_Type" and the request specifies one of the designated types (instead of a specific site), then the site selection dialog will only show sites of that type and "Requested Type" will be shown in the drop-down list where "All Site Types" is usually shown. You can override this if necessary to select different sites, by changing the "Requested Type" selection to something else. Obviously this is not recommended under normal circumstances, since you could be giving the customer a site they don't want.

If the request was for multiple sites (according to the "Number of sites requested" value, if present), then you must select exactly that many sites while in the site selection dialog. It will not allow you to save the selected sites if the quantity is not correct -- they must all be selected at the same time. Note that if it's for multiple sites, it will actually create multiple reservations as it always does for multiple sites, and they will all be linked as synchronized reservations.

Send an E-mail

This function can be used if you need to send the customer an E-mail to ask for more information, or perhaps reject the request. This will open an E-mail window where you can enter your message. However if you intend to accept the request and just need to send an E-mail confirmation, you should use Save & Continue to Details, and do Quote/Confirmation from there (see below).

Save ... Done

If everything looks OK on the request and you don't need to do anything more than save it as a real reservation now, click this button. Some validation will be done, and if everything is OK then it will be saved.

Entering a Deposit

If you use a 3rd-party online service, then the actual deposit might be received and processed by them already. If you have appropriate parsing rules set up, the Transaction for this deposit will be created automatically, so no further handling would be needed.

If you retrieve credit card information from the request and need to process the deposit locally, then you will need to do that manually. First you will use the [Save & Continue to Details](#) function (covered below), which will take you to Reservation Details. From there you will go to [New/Edit Transactions](#) and enter the deposit just as you would for a phone reservation. If you're handling credit card charges in Campground Master, you would do the credit card processing there as well. Note that it helps if you have the parsing rules extract the credit card information into the Guarantee Info field for the reservation, so it will be used automatically when you go to enter the deposit transaction.

Sending a Confirmation

Again, if you're using a 3rd-party online service, then that service probably already sends a confirmation to your customer. If you're taking requests from your own web site, however, you probably want to send them an E-mail confirmation now. To do this you will first select [Save & Continue to Details](#), enter the deposit if needed, then use the [Quote/Confirmation](#) function to send the E-mail confirmation (just like when you take a phone reservation).

Save & Continue to Details

If you're ready to save the request but want to make other adjustments, or perhaps need to process a credit card deposit or send a confirmation E-mail, then select this option. The request will be saved as a real reservation and you will be shown the Reservation Details. You can do anything there that you would normally do after creating a new reservation. Once you're done, you will be taken back to the list of requests. (If you need to go back and do more with it, you can get to it easily from the list of requests by using the View / Process function again.)

Save as an Inquiry only

There may be times when you need more information from the customer before saving the request. Use this function to save the request with the current information as an "Inquiry" reservation. Then when you get the information you need, you can locate the inquiry through the Non-Reserved tab view to edit it and change it to a "Pending" or "Guaranteed" request.

Note: If you want to request the needed information by E-mail, it's easiest to use the [Send and E-mail](#) function before saving it as an inquiry, since you won't be able to come back into here after you save the request as an inquiry. Otherwise you would need to go to Reservation Details, then Customer Details, then click on the E-mail link there to send an E-mail.

Duplicate Customers

After you Save a request, Campground Master will check for any similar customers in the database (by last name and zip/postal code). If it finds a potential match, it will ask if you want to merge them to avoid duplicate customer entries. If you do, then the Merge dialog will be shown so you can verify the information and choose which customer record you want to keep. The one you don't keep will be deleted and all of its reservations and transactions will be transferred to the one you do keep -- so you can either keep the original one or the new one, depending on which one has the more accurate or complete information.

Uploading Site Availability Data

Once all processing is done, or any time you want to update the sites available on your web site (if using Export to Web Vacancy Grid) or Hercules (if using the 2-way interface), then access this function through [Reservations / Retrieve Online Reservations](#). It's not necessary to retrieve or process any requests before using the Upload function here -- you can do it any time, for instance after entering reservations locally, if you want to keep the online information current.

The type of "Upload" done will depend on the Source selected, as described below.

Hercules 2-way -- This will upload any new reservations or changes to reservations waiting in the queue. This is not necessary if the Outgoing mode is "Fully Automatic", only if it's "Manual".

E-mail -- Regardless of where the E-mail requests actually come from, the Upload function for the E-mail source is actually the same as the Export to Web Vacancy Grid function through File / Export. However when you use the Upload function here, it will automatically do both the Export step and the Upload step in a single click, without showing the Export to Web setup dialog. This assumes of course that the Export to Web FTP settings have been set up in Online Reservations - Connections & Options. Otherwise it will export the pages and then show an error message indicating that it can't do the upload step.

iCal files -- This will export and optionally upload the iCal files as directed by the iCal Profiles. See the section [Exporting to iCal Files](#) for more details.

Exporting to Web Vacancy Grids

The Export to Web Vacancy Grid function is accessed through the File / Export Menu. This dialog contains a sections for setting up the export details as well as the export and upload functions.

If you're using the Online Reservations functionality to retrieve and process E-mail reservation requests, this export function is also considered the "upload half" of E-mail processing since both are most likely associated with your own web site. Thus the "Upload Site Availability" function on the online request dialog also uses this function, but without actually opening this dialog. Thus you'll need to make sure things are set up appropriately here before using that upload function.

Overview

The Export to Web feature allows you to show vacancy status on your web site, essentially like a compressed Rack view with no customer details. The pages can also have active links in each vacant cell on the grid which make a reservation request for that site on that day.

The program will generate the web pages to your specifications, and then you will need to upload them to your web site. There is an Upload button on the dialog which you can use to upload the pages after creating them, if you've configured the FTP settings (see [Maintenance / Online Setup](#)). Therefore you could easily upload the changes several times per day as needed. You can also use any 3rd-party FTP software to upload the pages after using the export function. The pages can also be time-stamped so the web site visitor knows how recent the page was updated.

One or more sets of 12 pages will be generated, one page for each month for the next 12 months (the current month may be partial, starting with the current day). You can select what sites are shown on each set of pages -- show all sites in one set, or make a separate set for each Site Type or Site Class. If you have multiple Parks set up, also have the option to generate a separate set for each Park.

Selecting Sites

To select which sites to include on the pages, use the "Select Sites to Include" button. This will open the familiar Site Filtering dialog, where you can select the sites to include by individual site or by Type, Class, and Park.

Next you can choose whether to show all sites on one web page, or create separate pages by type, class, or park. Of course this will depend on how you want to present them on your web site -- your web site will have to include a link to the first page of each set. Only one link is needed if they're all in one set, while many separate links might be needed if you show a different site type or class on each page. Note that you only need to link to the first page in a set (the current month) -- the generated grid will already contain links to the other months.

Date Range

You can select the starting and ending date of the exported grids. By default it will start today and go 365 days into the future. However if your season hasn't started yet, you can select a different starting date (but don't forget to change it back to "Today" once the season starts). Likewise, you can limit the ending date to either a specific date (end of season) or to a number of days into the future. If you have a slow internet connection, you may want to limit the grid to 3 or 4 months just to minimize the size of the files to be uploaded.

Template File(s)

The web pages will be generated using templates of your own design, so you can match your web page's style. The templates are basically HTML web page files with two insertion markers in the page:

```
###VACANCYGRID###
```

This must appear exactly as shown somewhere in the template file. The HTML code for the entire vacancy grid will be inserted here, replacing the marker. (Don't put it inside a comment tag, or else the entire grid could be commented out!)

```
###ASOFDATE###
```

This marker is optional, and will be replaced by the current time and date. This is just for the visitors' reference, so they know how recently the grid was updated. This could be placed at the bottom of the page below the grid.

Template File Path

Enter the path containing the template files, or use Browse to locate them. Browse will open a File-Open dialog for the file type ".htt" and a dummy name for the file -- just navigate until you find the folder with the templates and click Open.

The file or files must be named a certain way:

If showing all sites on one page, the template must be named "All.htt".

If showing separate pages by type, class, or park, you must have one template file for each type, class or park. This allows you to have different formats or links on each set of pages, accordingly. The template must have the type/class/park name, followed by ".htt". If the name contains spaces, replace the spaced with dashes (minus signs). For instance, for the site type "Normal RV", the template would be "normal-rv.htt". It doesn't matter if the letters are upper-case or lower-case.

An example "All.htm" template file has been installed to your Campground Master folder. You can copy and/or modify that file as needed. It is a text file, just as all HTML files are text.

Output File Path & Extension

Enter the path for the generated web page files. This can be the same as the template path or different. Also select the file extension to be used (the proper extension will depend on your web site design).

When the files are generated, the template names will be converted to lower case and will be prefixed by "vacancyMM", where MM is the month offset (00 for the current month, 01 for the next month, etc.). For instance, "vacancy00all.html" if you're exporting all sites on one page, or "vacancy00normal-rv.html" for the Normal RV site type if you're exporting separate pages by site type.

Formatting

You can use the Repeat dates setting to adjust how often a new set of date column headers appears in the grid. We recommend every 20 rows, so that when the visitors scroll the page they will always be able to see the headers, even if they have a low-resolution monitor. You can change this value to fit your tastes, or blank it out to avoid repeating the column headers at all (except the top and bottom, which will always have them).

The font face and size for the grid can be entered to match your web site. Keep in mind that these are the literal strings that will be used in the tags in the HTML page. The font face will be enclosed in quotes (so you don't need to enter quotes).

You also have complete control over the colors used in the grid. Use the Define Grid Colors button, which opens up a Color Key dialog for defining the colors. Note that some color definitions only affect the foreground or background color -- these are indicated with comments like "BG ignored" and "FG ignored". Some colors can be defined separately for Mon-Fri cells and Sat-Sun cells, so weekends can be seen easily.

Finally, each vacant site in the grid can have a text designator in it for Vacant, Reserved or Unavailable, and the "V" (vacant) cells can optionally be linked to a script on your site, or set up to generate a simple E-mail request for a reservation. You can define the link format to anything you want -- it will be enclosed in a hyperlink tag like .

Link Format

The default link format can be used to send an E-mail to you with the details of the request. (Of course you will need to insert the correct E-mail address yourself). In case the default link is overwritten, here is a suitable default:

```
mailto:(your park E-mail)?subject=Reservation%20request%20for%20site%20<site>,%20arriving%20on%20<date>
```

Note that any non-alphanumeric characters in the link format after the "?subject=" part should be entered as "escape sequences" using percent signs (%) and 2-digit hexadecimal values, to avoid problems with some web browsers. Thus in the example above each %20 is actually the space character (the space character's value is 20 hex, or 32 decimal). You might want to refer to an "ASCII character chart" for reference, if you need to include other values. Once the above line is read by the web browser and the escapes converted, it will become:

```
mailto:(your park E-mail)?subject=Reservation request for site <site>, arriving on <date>
```

The link can have <site> and <date> markers in it as shown above, which will be replaced automatically by Campground Master when creating the HTML files, to include the site and date for the corresponding cell that the person clicked on in the vacancy grid. There are actually 4 different date formats that can be specified, so you can use whichever works best for you our your web site:

Marker:	Example:
<date>	May 23, 2006
<date-mdy>	5/23/06
<date-dmy>	23/5/2006
<date-ymd>	2006-5-23

If you have an existing reservation-request form on your site, your webmaster may be able to set up a cgi-script which can be used in place of this E-mail link that will automatically jump to the form and insert the site and date information. It's also possible to extract the parameters using Javascript code in your form's web page. To pass the site and date as parameters to your reservation form page, use a link format like this:

```
http://www.mywebsite.com/reservationform.html?<site>&<date-mdy>
```

Note the "?" and "&" characters before <site> and <date-mdy> -- these are standard separators for parameters in links. Sample Javascript code to extract these parameters into your form's site and arrival date fields has been included in the next section.

Finishing the Export

When everything is set the way you want it, click the [Export Web Page Files](#) button. The pages will be generated and you will see either a "success" message or an error message, if something didn't work (e.g. a template file was missing).

All of the settings will be saved when the dialog is closed, so the next time you want to generate the pages, you only need to click the Export Web Page Files button.

Uploading the Pages

After exporting, you still need to upload the pages to your web site (unless you host it on your own computer, which is not usually the case). There are many good FTP programs available to assist in uploading, or you can use the built-in FTP uploading function.

The primary benefit to using a 3rd-party program is that the uploading can be done in the background while you continue to use Campground Master, whereas the built-in function must complete the upload before you can use other Campground Master functions.

To upload the pages with Campground Master, simply click the button [Upload Files to Web Site](#). (The FTP settings must be configured first -- see Maintenance / Online Reservations / Other Online Interfaces / Online Reservations Connections & Options). A progress window will be shown to indicate how far along it is. Once the upload is complete, you can close the dialog.

Sample Javascript to Insert Form Values

If you already have a reservation form on your web site (using the standard HTML <form> tags), you can use Javascript to extract the <site> and <date> parameters from vacancy grid "V" links and use them as default values in your form. If you don't yet have a reservation form, or if you want an example form that will work well with the Online Reservation functionality, see the next section.

To get to the Javascript sample, go to Help / Help Topics, select the Index and look for "Javascript".

Sample Web Reservation Form

We've put together an example of a web form that you could use on your web site, along with the Parsing Rules needed to extract the data form the E-mail you would get when someone fills in the form.

The sample form, along with a CSV file with sample parsing rules that would parse that particular form, can be downloaded from our web site. The parsing rules CSV file can be imported to a parsing set through the Edit Parsing Set dialog.

From our web site's home page, click on "Support" ... "Downloads" in the menu, and go down to the bottom to locate the "Sample Online Reservation Form" links.

Keep in mind that this is only an example -- since it uses some default values for selections like How-Heard, Rig Type, Site Type, etc, it probably would not be appropriate for any particular park without modification. Your web site designer can use this to start with or get some ideas from, but it needs to be tailored to your particular application before actual use.

This also assumes that your web provider has some kind of form script that you can use to handle the HTML "<form>" processing. In the sample form, a CGI script called "formmail.pl" is used. This happens to be what our web host supplies, but other web hosts may use a different script or you may have to set up your own (formmail is a popular one that can be found various places on the web).

12 Maintenance Functions

Overview

Maintenance functions, available in the Maintenance menu of the main menu, are functions that are typically used only occasionally to setup up the database or make certain "dangerous" changes to the database. None of the maintenance functions may be accessed by an operator with less than a Manager access level, and only the Backup and Restore functions can be used by a Manager -- the rest of the functions require Administrator access.

Back Up and Restore Database

The reasons to make backups are covered earlier in the section *Setting Up Your Campground Database*, so it's assumed that you will be doing this on a regular (**daily**) basis. Your data is too valuable to lose, so don't skip this step! Making a backup is very simple. In fact, after the first backup is made, it can be done with 2 or 3 mouse clicks. In addition, the software will remind you to do a backup if you haven't done one recently (the default reminder is every 3 days).

A backup of the database is simply a compressed copy of the database files (in standard "ZIP" format), which can be used to restore all of your data either on the original computer or on another computer with the Campground Master software installed. Normally backups are made to a USB memory stick or CD-RW disk since any computer can read these. If you have a more sophisticated computer setup, you might make backups to other kinds of removable storage or to another computer on the network. (We recommend using removable storage, since backing up to another computer does not allow for easy rotation of daily backups or for keeping a portable copy off-site.)

Backing Up

Before making your first backup, you need to decide where you're going to back up your files. Some other options were mentioned above, but for this discussion we will assume that you will back up to a floppy disk, which is normally your A: drive. If you use a CD or memory stick, the drive letter might be D:, E:, etc.

After inserting a disk in the drive, just click on the "Safe" icon on the toolbar to start. You will see a "Save As" dialog, which is the standard Windows file dialog for saving files to a specific location. From there you need to do two things -- enter a file name and select a location for the file.

The first part will actually be done for you in most cases. You should see the name of your database in the File name field, possibly with a **.zip** extension instead of the normal **.prk** extension. If you don't see anything in the File name field, or if you prefer to name your backups differently (for instance you could use a different name for each day), then you can change that name. You should either leave the extension the same, or enter a name with no file extension (in which case it will use the default extension of **.zip** or **.prk**). Whatever name you use here, it will be remembered and used the next time you make a backup.

VERY IMPORTANT: You need to select a location for the backup. If you have backed up before, the previous location is already selected for you. If this is the first time, you will need to select it from the **Save In:** drop-down list at the top of the dialog (called Look In: on some computers). Assuming you want to save it to a memory stick, this may be as simple as clicking on the list to open it and clicking on the appropriate drive selection letter, like **E:** (you'll need to know which one is the memory stick drive, often shown as "removable disk"). If you don't see the drives listed, click on My Computer to open up that folder, then click on the same drop-down list again.

Now that you have a file name and location selected, click the Save button on the dialog (or OK on some systems). If there's a previous backup on that drive, it will show a warning that there is already a file by that name on the disk, and ask if you want to replace it. Answer Yes to proceed with the backup.

While the file is being backed up, the cursor will change to an hourglass. You can't do any other functions while the file is being backed up. Initially it should only take a few seconds. As the database grows, it will take a little longer to back up. Once the backup is finished, a "Backup Complete" message will be shown.

That's it, you've created a backup! Now the next time you back up, it can be done in 2 or 3 clicks -- click on the Safe icon, click Save (since the location and file name will be recalled from the first time), and click Yes if it asks you to confirm replacing the file.

Backing up to a CD (CD-R/W) drive (Windows XP or later)

Note that backing up to a CD is not supported on all systems. This is very dependent on the specific Windows configuration, hardware setup, and other software installed. A USB flash drive is currently the best device to use for backups (or you can direct them to a cloud backup location like DropBox). That said, if CD's are all you have to work with, you can try it...

If you're using Windows XP or later with a CD-RW drive, then you can select the CD-RW drive as the backup location in Campground Master. The file will actually be placed in a holding area where Windows will see that it's waiting to be recorded on the CD, and then Windows will prompt you to record the file (something like "Files waiting to be written to CD" will appear in the lower right corner). Be sure to follow the prompt from Windows, or else the file will not be recorded to the CD!

If you get an error when attempting to create the backup, then your CD driver software doesn't support direct writing to the CD.

Using floppy disks

Still using floppy disks? Believe it or not, Campground Master can back up large databases to multiple floppy disks if needed, assuming your computer is old enough to use floppy disks. You will be asked to "Insert disk 2 of the set" and so forth until the backup is complete. If you're using multiple disks, make sure you have each one labeled according to disk number (disk 1 of 2, disk 2 of 2, etc.) and that you have enough disks in rotation to make a set each day.

Automatic Backups

As an added precaution, the program automatically makes a backup at the start of each day and places it in the same location (folder) as the database file. The automatic backups include the date in the file name, and are kept for 32 days by default. Older ones are automatically deleted, and the number of days they're kept will be the same as the number of days for log files (see *Maintenance / Program Options / Database*). However, since these backups are still vulnerable to computer malfunction (hard disk failures, viruses, etc), **this is not a substitute for making manual backups!** This is only an extra safeguard in case you delay in making regular backups.

If you need to restore from one of the automatic backups, simply use the Restore function as described below, but navigate the Open dialog to your database folder. You will see a series of files with your database name plus "_Auto_Backup_" and the date. (They will be .zip files, so be sure you're looking for the .zip file type.) Select the latest one and restore from that file.

The Automatic Backups mentioned here are part of the basic program function and should not be disabled or the number of days reduced, since the program can call on those whenever necessary to recover from database corruption.

Scheduled Backups or Secondary Automatic Backups

The Automatic Backups are great as a last resort, but you should also be making other backups as mentioned above. Many users prefer this to be automatic as well, and/or want to choose the location for those such as an external hard drive, mapped drive on a separate computer, or a cloud drive. A second location to store auto-backups can be configured under Maintenance / Program Options / Database. See that section for details.

In addition, it's possible to schedule backups at a particular time and to a particular location. An article explaining how to do this can be found in Newsletter #41, available online or through the Help menu of the program.

Restoring from a Backup

We all hope it never happens, but the day may come when your computer malfunctions or some other problem requires you to restore the database from the backup copy. Hopefully you had been making daily backups so you won't lose more than a day's work. (This is also a good reason to keep copies of printed receipts for at least a day or two, in case you need to re-enter reservations.) This function can also be used to load the database that was backed up from another computer. Also, as long as you haven't disabled the logging function, it can also apply all changes made since the last backup automatically, so you shouldn't lose anything if the files are intact.

Restoring from a backup is just as easy as making a backup, but there are more steps and warnings because it's inherently a risky function. Even with a perfect backup, you are asking the software to load a database that may be older than the one it's currently using, so you need to be sure that it's necessary.

To start a Restore, select Restore from Backup on the Maintenance menu. Remember that you must have Administrator access to use this function. After one or more warnings (depending on whether the current database is saved and whether you've done a backup from this computer), you will see a File Open dialog.

IMPORTANT: If you have done backups from this computer, it will assume you want to restore the last backup made and will fill in the file name and location accordingly -- so all you would have to do is click the Open button. If this is a new computer and you have not made a backup on it before, then you will have to navigate to the location of the backup file (as in Backing Up above), and select the backup file name from the file list. This may be the removable drive letter, eg. E: (locate it with the "**Look In:**" drop-down list), or in some other location.

Once the File name field has the proper name in it, you can click Open. Now it will load the backup from the disk (asking for other disks in the backup set if necessary). Once that is done, you will be informed that the pre-restore database has been saved (to a file with the time and date in the name), in case you need to revert to that database.

Multi-disk Note (for legacy floppy disk support): If your backup required more than one disk, you should insert the last disk of the set first (e.g. disk 2 of 2). Otherwise you may get an error message that the restore failed. Once you've inserted the last disk and started the restore, it will ask for each disk as needed.

Once the backup database is loaded, you may see a message indicating that there are changes in the logs that are not in the database -- this is normal, since you are restoring from a backup, and you should answer **YES** to the prompt so that the logged changes are restored also. (The only exception to this is if your actual purpose for restoring was to undo some drastic changes.) If all goes well, the database will be back to the way it was, with all changes intact.

Finally, a confirmation message will be shown.

If you are sure that the database you just loaded from the backup is the data you want, then you can continue as normal (you will need to log in again, since the restoration procedure automatically logs out the previous operator). If you're not sure yet, read the following section carefully.

IMPORTANT: The restore operation should be done while the original database file is opened (i.e. the current database name and location are the same as it was when it was last used normally), otherwise the program won't be able to check the log files for post-backup changes. It's also important that the database be saved to that same location after the restore is done. If the database cannot be opened from the original location for any reason, then the following procedure is recommended:

1. Open whatever database you can (even the sample database if necessary), and restore from a backup as above -- but then immediately do a **File / Save a Copy As** to save the database as the original name, and the original location. Be sure no changes are made before you do the Save -- don't even look around in the data, since that can cause changes to be logged.
2. Close Campground Master, and re-open it. The database should be re-opened automatically (assuming you didn't use the Sample Database icon). Then you may see a message indicating that there are changes in the log -- answer YES to apply the missing changes. Now you should be fully restored.

Aborting a Restore Operation

Assuming you have just completed the Restore and done nothing else, you still have a chance to change your mind and get the previous database back. This is because the pre-restore database is saved to a unique filename. So if the restored data is not what you want, you can still get back to the database you had before the restore using **File / Open**. Just locate the pre-restore file (it will contain " PRE-RESTORE " in the file name, along with the date and time), which will be in the same location as the database. However, that will become your new current database when you open it -- so then you need to use **File / Save a Copy As** to save the data back to your normal database name and location.

Rename Database

This function is found under the **File** menu. It will allow you to enter a new name for the currently open database, performing these steps automatically:

- Saves a copy of the current database to the new name, under the "safe" location (*Shared Documents* in Windows XP or *Public Documents* in Windows Vista, for example).
- Keeps this database open.
- Makes this the new default database (assuming the database you had open was already the default database, or if there was no previous default).

This function is particularly handy for instance if you've Restored the data from a backup on a new computer, but forgot to name the database before restoring it. It can also be used if you have been using the demo database during a trial and now need to save it under a different name. Note that it will not rename the actual database file you have open, it only saves a copy under the new name. So the original database file, if any, is not altered.

Check for Updates

This function is found under the **Help** menu. You can use it any time (assuming you have an internet connection) to see if there is a newer version of Campground Master available for you to install. If so, then there will be a button to go check it out on the web site (and pay for updates renewal if necessary). Also, if your updates are current and you are eligible for the update, a button will allow you to download it and run the installation immediately (assuming you are logged in as an Administrator).

E-mail database and logs to support

This function is found under the [Help](#) menu. For certain technical support issues, you may be requested to use this function to send a copy of your database files and/or other files to support technicians for diagnosis. This function makes it easy to do so.

NOTE: Please use this function only after requested by support. If a database is send without it being requesting first, support technicians will not know the history of the issue and will not be able to help you.

Include current database -- You will almost always want to include the current database, so that option should be checked.

Include an auto-backup -- If an older database is needed for comparison, you can select an auto-backup date to include here. These backups are always on the computer, so you don't need to look for your manual backups.

Include log files -- If logs are needed to investigate specific activity, you will be instructed to include a certain number of past days of log files.

E-mail text / additional notes -- You can enter as much text as you like here, to further describe a problem or give any details requested.

When all options are selected and you're ready to send, click the **Send** button. This will send it through our own E-mail server. It may take several minutes to send, so don't do it during a busy time.

Park Setup Functions

Overview

The functions under Park Setup are for editing the Park, Site, Taxes, Rates and Operator tables of the database, plus a few other things. These are primarily used when setting up the database, but of course you can use them to make changes to the sites, edit the park notes for the receipt, add or change operators, and so forth. Administrator access is required to view Operators, and also to add or delete parks and sites. You can view and edit parks and sites with Manager access, but cannot add or delete them unless you have Administrator access.

The Park, Site, and Operator dialogs works the same as the Customer Details dialog. They have navigation controls at the top to step through records, add a new record, delete a record, and print a record. See the Customer Details dialog (in the *Working with Customers* chapter) for information on the common navigation controls, and the appropriate section below for specific details.

The other dialogs (Taxes, Rates, Notice, and Confirmation text) are unique in their operation -- see the appropriate section below for details.

Parks Setup

(Accessed through [Maintenance](#) / [Park Setup](#) / [Parks](#).)

Usually you will have only one Park record. This is used for the park info on the receipts and a couple other things. This is also where your software license authorization code is stored, which is keyed to the park information.

One reason to have more than one park record would be to show different information on receipts for different sites -- for instance, you might want to print different Additional Notes on the receipts for your RV sites than for your cabins or tent sites. You can add as many Park records as you like, using the same Authorization code for each, as long as they each have the same Name, City, State and Zip code. (The Short Name of each record should be different, as described below, so that each park can be selected on the reports.) If you need separate park records with a different name or address, contact Cottonwood Software for an additional park license.

You can print an entire Park record or a form with the [Print](#) button. This opens the Form Selection dialog, which gives you the option to print a [grid](#) or a [form](#). The grid format prints a simple table with each field name and value, generally meant for reference purposes. You can also choose to print any Form defined for this type of record, which allows you to easily access any custom form you've created for Parks.

The individual park fields are described below.

Park Name, Address, Phone Number, Email, etc.

The only critical information of these is the Park Name and address, which is used for authorization. In addition, the Park Name is used in the Sites setup for selecting a park record for the site.

This information is also used for the printed reservation and transaction receipts. The Park Name, address, all three of the phone numbers, E-mail, Web and Owners information will all be printed on the receipts in the park information box.

Short Name

This field must be filled in! The Short Name is used for selection lists when selecting a park for each site, and selecting parks for filtering (if more than one park is defined). This can be anything you want to use to identify the sites that will be grouped for this park, but should be about 10 characters or less for the best results. It could be an abbreviation of the park name, or something generic like "Campground" or "Marina".

Check In and Check Out Times

The Check In and Check Out times will be shown on reservation receipts for the customer's reference. If you don't want to show these on the receipt for **any** Sites in the database, then you need to disable these fields under Maintenance / Data Field Definitions / Park Fields. If you want it hidden from receipts only for certain sites (e.g. storage units), you can use the "Hide check in/out times" option in Site Details for each site.

The Check Out time is assumed to be the next morning, and this will be indicated on the receipts. For instance if the "Last Night" is Friday, the check-out time is assumed to be on Saturday morning. If this is not the case (e.g. for flea markets where they must leave that evening), then uncheck the box "Check out is the next morning".

Different Check In or Out Times

If some sites have different check in/out times, e.g. for Cabins vs. RV sites, then you can override the times for individual Sites. See *Edit Site Details* for more information. Tip -- put the most commonly used times in the Park record, to minimize the number of sites for which you have to enter individual times.

Meter Wrap-around numbers

For each meter type, enter a number corresponding to the capacity of the meter readings. This will usually be a 1 followed by the number of zeroes corresponding to how many digits the meter has -- for instance if a meter has 4 digits (0000 to 9999), enter 10000 as the wrap-around number (since it will go back to 0 instead of 10,000). Do not enter commas with the number, just the digits. These wrap-around numbers are used to properly calculate the meter charges when the meter goes from 9900 to 0100, for instance.

Note that the meter wrap-around settings will be used for each site that is selected to be associated with this park record (see Sites Setup). Therefore if you happen to have two different types of meters, with different numbers of digits, then you can override the wrap-around numbers for individual Sites. See *Edit Site Details* for more information. Tip -- put the most commonly used wraps in the Park record, to minimize the number of sites for which you have to enter individual settings.

Key Code

This is calculated by the software, and it can't be edited. (If you make changes to the park name or address, you may see the key code changing.) It's important that you do not make any changes that would alter this without contacting Cottonwood Software for a new Authorization Code.

Auth Code

This is your Authorization code for your software license. **Keep this code written down in a safe place!**

Without the proper code here, the software will be limited to either a number of days use or will not allow you to add sites to the database. This code will be created by Cottonwood Software, based on your Park information and the license details (number of sites, workstations, and product options you have). If you change this code, the program will check that it's a valid code and may report an error. If the code is not valid, the software will revert to Demo mode, which is limited to 100 reservations. Note that a valid authorization code must be entered for all Park records, otherwise it will revert to "demo" mode.

If you requested a full-function 30-day trial, you will be given a "trial period" code to enter. Once you purchase the full license, you will be given a new code to replace it, which will be entered here to upgrade the authorization levels. You may also receive a new code if you purchase upgrades or other optional features.

Download updated code(s) -- This button will check online for an updated code, e.g. after purchasing updates. Normally you would not use this button -- just manually enter the code we send you and Save. However if you forgot to enter it at the time you ordered, you can try this to see if there's a newer code for your license.

Notes

The Notes fields are used to add an Additional Notes section on the printed the Ticket Form of reservation and transaction receipts. You can have up to 3 notes of any length (assuming they fit on the printed page), and each of these notes will appear in a separate "box" on the receipt (it will have a border around it to separate it from the other notes).

Each note can be multiple lines, but is entered as one long line in the dialog field. If you type a long note, it will automatically wrap to multiple lines as needed on the receipt. But you can also control the formatting with the use of the "new line" escape sequence, `\n`. This way you can insert blank lines and force multiple lines where needed to format the note.

Here is a detailed example of a possible note field using multiple lines, which would be typed in one long string:

Please keep your campsite clean and free of clutter, for the enjoyment of all of our guests.\n\n -- Avoid storing items under your camper.\n\n -- Please no area mats or rugs, they kill \n the grass for the next camper.\n\n -- No outside clotheslines.\n\n -- Clean up after your pets. Baggies are \n available at the office if you need them.

Notice the `\n` sequences and the spacing, and imagine that you were typing this on a typewriter using the carriage return each time you see a `\n`. If you see `\n\n`, that means an extra blank line will be inserted. The output on the printed receipt will look like this (including the width as it would be on the receipt):

Please keep your campsite clean and free of clutter, for
the enjoyment of all of our guests.

-- Avoid storing items under your camper.

-- Please no area mats or rugs, they kill
the grass for the next camper

-- No outside clotheslines.

-- Clean up after your pets. Baggies are
available at the office if you need them.

Sites Setup

(Accessed through [Maintenance](#) / [Park Setup](#) / [Sites](#).)

This is where you set up all of your campground's rentable commodities -- anything that needs to be reserved on a daily (or nightly) basis. While this primarily applies to accommodations like camping sites or cabins, it can also apply to motel rooms, boat docks, storage sites, ballrooms, or even bicycles and video tapes. It's completely up to you.

You may be limited on the number of site records you can enter depending on the license you purchase. You can see the limit for your license in the View Product Authorizations dialog. You will get an error message if you try to enter more than you're authorized for.

The order of the sites in the Sites Setup dialog determines the order that the sites appear on the Rack tab view, and how they are sorted in other tab views, reports or drop-down boxes. Therefore you should plan the order to be most convenient for you, but don't worry about needing to insert records later -- you can insert sites where you need them or move them around easily.

Inactive sites will show "(INACTIVE)" next to their Abbreviation in the list. To make a site active again (or to set one inactive), view the Site Details for it and check the "Site is Inactive" box accordingly.

You can print the entire list of sites, or print a Form for any sites selected, by clicking the [Print List](#) or [Print a Form](#) button. If the [Print a Form](#) button is clicked, the Select Form dialog will allow you to choose which form to print for each selected site (assuming any forms are defined with Sites as the base table).

Adding Sites

To add a new site, click the **Add new site** button. This will open the Site Details dialog for a new site, where you can enter the information for it. See the next section, Edit Site Details, for more details. Once a site is added and saved, you will return to the Sites Setup and it will be added to the end of the list.

If you need to add a site in between other sites, select the site it should appear above and click the **Insert new site** button.

Tip: If adding more than one site, click "Add Site" in the Site Details dialog instead of Save -- this adds another one immediately and skips the step of coming back into Sites Setup.

Adding many sites at once

There is a function to **Add/Insert Multiple Sites**, making it very easy to add hundreds of sites in one step. But for adding your first few sites and changing individual sites, you should use the Add new site function and enter all of the appropriate details.

Editing Sites

To edit an existing site, simply click on the site in the list to select it, and click the **Edit site details** button. That will open the Site Details dialog where you can make any changes necessary.

Tip: If you need to make common changes to many sites, for instance setting an attribute, it may be much faster to use the Raw Data Tables function. In the raw data table you can edit the fields of all sites in a grid form, copy fields to multiple sites at once, copy multiple fields at once, etc.

Copying sites

You can copy one or more sites (create duplicates) to speed things up -- however, this also duplicates the names and abbreviations of the sites, which is not desirable (a warning will be shown). After copying sites, be sure to Edit the site details and change the abbreviations and names to something unique (e.g. different site numbers).

Make date(s) Available or Unavailable

These functions allow you to select any number of sites, enter one or more dates or date ranges, and will **add** those dates to the available or unavailable (blocked) dates for all of those sites. It does so by adjusting the "Special Dates Available" or "Special Dates Unavailable" fields of the Site Details. It won't modify the "Season Dates" setting. So for instance if you use "Make date(s) Available" but the site is already showing those dates as available, it won't change anything.

Deleting sites

Although you can delete a site from the Site Details dialog, it won't allow you to delete any site that has already been used for a reservation. This would result in an undefined site link if you ever view a reservation for this site. It's only safe to delete a site if it has *never* been used for a reservation, for instance when you are setting up sites for the first time. If you need to "remove" a site later, you should use the Site is Inactive flag discussed below. If you do delete a site by accident, you can add it back to the correct place using the Insert new site function.

Add/Insert Multiple Sites

This special function appears in Sites Setup and on the Raw Data Table dialog for Sites. It allows quick addition of sites or cloning of a site when setting up the database.

If you want to insert sites into a specific location in the table, first select the site that you want the new ones to appear after, before entering this function. (Note that this means you can't insert them at the very beginning -- but that's easily rectified using the Move function afterwards.)

If you're just getting started, it's best to have one "template" site already set up, for instance through Sites Setup. Then you can use this function to clone the site as many times as needed, incrementing the numbers for each site.

Now you can enter the number of sites (or duplicates) to create, prefixes for the site abbreviation, name, and description, and a starting number. Note that the number will always be included in the abbreviation and name, but is optional for the description. Prefixes are optional, and don't forget to type a space character if you want a space before the number, like "Slip 1".

If you want your numbers to be 0-padded, like RV001 to RV999, then you will have to do it in multiple steps, including the 0's in the prefix. For instance, create 9 sites with a prefix of "RV00", then 90 sites with a prefix of "RV0", then the rest with a prefix of just "RV". However, since the software doesn't really care how long the site name is, there is not much need to 0-pad the names (unless it's needed for importing reservations from an old database).

Finally, there are the options to duplicate the selected site, and whether to insert the sites or add them to the end.

When all options are selected, click the Go! button. In a few seconds, all of the new sites will be shown. Note that there is no undo function, but it's easy to delete the sites and try again if you make a mistake.

Edit Site Details

The Site Details dialog is used to view or edit all of the individual fields for a single site. It has browsing functions to step through sites one by one, as well as adding or deleting sites.

This dialog is accessed through the main Sites Setup function ([Maintenance / Park Setup / Sites](#)), and it can also be accessed by right-clicking a site in almost any of the tab views (Rack, Arrivals, On Sites, etc.).

You can print an entire Site record or a form with the Print button. This opens the Form Selection dialog, which gives you the option to print a grid or a form. The grid format prints a simple table with each field name and value, generally meant for reference purposes. You can also choose to print any Form defined for this type of record, which allows you to easily access any custom form you've created for Sites.

Site Fields

The individual site fields are described below. Note that some fields may not appear for you, for instance if the field has been disabled in your database (see *Define Data Fields*).

Abbreviation, Full Name, and Description

These fields should all describe the site, in increasing length and/or detail. Each one is used in different places to represent the site.

The Full Name must be filled in, and is used in most places where sites appear as a cell in a grid, such as Tab view reports, and in places where a full name is used like when viewing a reservation. You may want to include a word like "Site" in this name for clarity, like "Site 35" or "Lot 35", or you can be more specific like "RV 35" or "Tent 35". It should be limited to about 10 characters for the best results.

The Abbreviation is used where a shorter name would work best to save room or where "Site" would be redundant, such as in the rack "Site" header cells, the drop-down Quick-Pick list on the New Reservation dialog, and on the printed reservation receipts. Typically this is just an identification number like "35" or "C-35", but it should be unique -- don't use "35" for both RV lot 35 and boat dock number 35.

The Description is optional. If it's available, it's used in the pop-up tips whenever you move the mouse over a site name cell on the grids (either the row/column headers in the Rack or their fields in the other Tab views. If no description is available, then the Full Name is used. While this can be as long as you like, it works best when 20 or fewer characters are used. This is just so it doesn't obscure too much of the screen when it pops up. Examples: "Site 35 - 30A/W/S", "Site 35 - Maple St.". The use of this field depends on what helpful information you would like to see when you move the mouse over a site's cell.

Park Selection

This is a drop-down list with a list of the defined Park records (usually only one selection). You should select one of the parks for the site even if there is only one park defined, since it's used to determine which park's information is printed on the reservation receipts. See the *Parks Setup Dialog* section for more information.

Note: If you don't see anything in the park selection list (e.g. when you click the down-arrow to show the list), that means the "Short Name" field of the Park record(s) has not been filled in. Go back to Park Setup to fill this in, then you can select it from the list.

The park selection is important, especially if you have more than one Park set up, as it's used to get various information from the proper park record for reservation and transaction handling. This includes the check in/out times, meter wrap-around numbers, and the address for receipts and envelopes. It can also be used for report filtering.

Confirmation Text

This option is disabled by default since most parks won't need it. When this is enabled (through Maintenance / Data Field Definitions / Site Fields), you can set the bottom text of confirmation letters to be different for each site. If the text is blank, then the default text will be used (set through Maintenance / Printed notices & text / Confirmation letter text & options). If there is any text in this field, then the default bottom text will be ignored and this text will be used, for this site only.

Host Confirmation Text and Host Address

These are special fields that are only used for certain circumstances -- in particular, if you're renting guest houses where the guest's host needs a separate confirmation letter. These options are disabled by default since most parks won't need it. When this is enabled (through Maintenance / Data Field Definitions / Site Fields), you can set the bottom text of the special host confirmation letter and the host's mailing address for the letter.

Address lines

You can fill in these if you want the receipts to show the message "Have visitor mail sent to:", and the 2 lines of address information. Only 2 lines are available, so it's suggested to use one line for the street and lot number, and the other for the city/state/zip. Since these fields are only used for printing purposes, they are optional.

Phone numbers

As with the address lines, these are optional and only used to print "Your phone number(s):" on the receipts. You can enter 1 or 2 phone numbers, and these would typically only be used if the site has a fixed phone number, such as for instant-phone sites.

Site Front/Rear/Left/Right

These fields allow you to indicate which site is physically in front of, in back of, and to the right or left of this site. They are not used in any particular way other than for reference, since they only appear on this dialog, so they are not required. (In future versions they will allow support for functions like automatic selection a number of adjacent sites or to assist in making "buddy" or group reservations.)

Since each one of these is a drop-down list of all sites defined, one obvious problem is that you can't fill in this field until all of the sites are defined. So you would need to go back through the sites after setting them up to set these fields.

Site Class and Site Type

These are pick-list selections, which you can define. They are attributes used in the Site Preferences selection when making a reservation, so you can set them according to what would help select appropriate sites. They are covered in more detail in the *Pick Lists* section. In addition, Site Type is used in nearly every filtering or selection process, so it is the most important field for site categorization. If you have the appropriate operator access, there will also be a special selection at the bottom to edit the Pick List, e.g. "Edit Site Types list...". You can click on that to directly jump to the Pick List editing function, without leaving the Site Details dialog.

More Site Attributes

This button opens the Site Attributes dialog, which is a list of attribute fields (including some of those above). In general, these attributes are used to filter out acceptable sites for a reservation, using the Site Preferences function on the New Reservation dialog. The site attributes here will correspond to the site preferences for a reservation.

Any attributes that are set will also show up in the Quick-Info window (double-click on a site name in tab views), so they can provide useful information to a customer when making a reservation.

The initial database will have many typical attributes by default. You will want to disable any that don't apply to your campground, and may want to rename a few to something more applicable. (This is done through *Define Data Fields*.) The number and the detail of these selections will depend on your campground -- a large diversified RV resort may have sites with many different attributes to choose from, while a small campground with mostly similar sites may only have a few. If you are extremely familiar with your park and each site's peculiarities, you may actually never use site attributes/preferences when choosing a site for a customer.

There are several different types of site attributes, and setting them in the Site Attributes is a little different for each one. In general, if you plan to use the Site Preferences dialog to select sites, you should set these fields appropriately for every site. If you leave an attribute blank, then the site may be assumed to be a match anyway (because the software doesn't know if it's a match or not). To enter any attribute, click on the right-hand cell next to the name and type the value, or double-click on the cell to drop down a pick list. If you're editing several in a row, you can use **Tab** after each one to step to the next one.

Pick-Lists -- These are simple drop-down lists, including the Site Type, Site Class, etc. Just select the appropriate selection for each site. If you leave it blank, the site will match to any request for that attribute. Note that some of these are duplications of the fields on the Site Setup dialog, and setting them here will also be reflected in the Site Setup dialog.

Sizes, Min #'s & Max #'s -- Some attributes are sizes, such as rig length. Sizes are assumed to be measured in feet. You should put an appropriate size for the Maximum, so that any request for that size **or smaller** will be a match. Just type in a number, no punctuation or other characters (for instance, type **45**, not **45 feet**). If you leave it blank, any size request will be considered a match. Attributes of Max # of Adults, etc., should also be entered as simple numbers. For some fields like # Adults and Rig Length, you can also set a Minimum size or number, to keep smaller rigs off of larger sites, for instance. As always, leaving it blank means that there is no minimum (same as 0).

Yes/No attributes -- These are fields that are either true or false, like Has Water, Has Sewer, etc. Their value can be either Yes or No, which can be chosen from the drop-down list. Alternatively, you can just click the field and press the **Y** or **N** key. A blank attribute will be treated the same as No.

Distances and Ratings -- These attributes are "ratings", and have a value of 1 to 5. Either way, a 1 means "low" (or "far") and a 5 means "high" (or "close"). For instance, Distance to Pool would be 5 for the closest sites and 1 for the farthest sites. View Rating would be 5 for a great view, 1 for a poor view. If the customer requests "Must Have" for one of these attributes, they will currently be a match as long as the value is 3 or above, or if it is blank (meaning not applicable or unknown). If they request "Must Not Have" then it will be a match if the score is 3 or lower. (Thus a rating of 3 will always be a match.) Future versions of the software will generate scores based on the how well the values match, and allow selection by how well a site score compares with the requests.

Min Stay and Max Stay

These represent the lower and upper limits on the number of nights allowed for a site. For instance, if you have sites where you only allow short-term stays, you can enter a 30-day maximum. Likewise, you can enter minimum stays for sites that are limited to extended stays. Only enter the number of days here without text, e.g. just enter "30" for 30 days or a month, not "30 days" or "1 month".

These limits are used on the New Reservation dialog when Show Available is selected. Any sites that are not allowed for the number of nights of the reservation will not be shown in the mini-rack when Show Available is checked.

Schedule

This field is only used for selecting an intra-day schedule, e.g. for hourly rental "sites" like canoes and tours. It should be left blank for normal daily-rental sites. See Schedules Setup for details.

Check In/Out times

Normally, the Check-in and Check-out times shown on receipts comes from the Park record (Park Setup / Parks). This makes it easy to set a single time for the whole park. However, you may have different times for different sites, so this allows site-specific times to be set up without creating separate Park records.

Before setting different times, you will need to enable the appropriate fields. In Site Fields, enable "Override Checkin/out", "Checkin Time", "Checkout Time", and "Checkout same day". Now you can click on the Check in/out times button to select the "Override" option and set the times (and next-morning option) for this site.

Don't show check in/out times on receipts

If you prefer not to show check in and check out times on the receipt for this site, for instance if it's a shelter or pavilion where this doesn't apply, then you can set this option to skip printing that information.

Electric Meter, Gas Meter and Water Meter fields

If these are enabled, you will see fields for the Reading and the Date, and a button to View the reservation that the meter was last read by. The reservation button will be disabled if the last reading was entered manually (on this dialog) rather than entered as a reservation transaction. The date will be disabled if no reading has been entered (which typically means that this site does not have a meter).

Assuming this site supports meter(s), you will first set up the site by entering the current reading (or the last reading that has been charged for). The date will automatically change to today's date when a value is entered, but you can override that if needed. If a meter is brand new and has a "0" reading, you should still enter a 0 in the Reading field so that the site is flagged as having a meter.

There is no way to select a reservation for the reading other than going to that reservation and entering a transaction for the meter reading. This is the way it should be done whenever a reservation is paying for the metered electricity, gas or water. Otherwise the reservation link will be cleared. Also note that if it's important that you have the reservation information when first entering the meter readings, this could be done by entering it as a transaction for the reservation (you can delete the charge afterwards but the site will remain updated).

Meter Wraps

Normally, the wrap-around numbers for meters comes from the Park record (Park Setup / Parks). This makes it easy to set a single wrap-around number for the whole park. However, you may have meters with different numbers of digits on different sites, so this allows site-specific wraps to be set up without creating separate Park records.

Before setting different numbers, you will need to enable the appropriate fields. In Site Fields, enable "Override Meter wraps" and also the appropriate wrap fields for the meters you have enabled ("Wrap Electric Meter", etc)". Now you can click on the Meter Wraps button to select the "Override" option and set the wrap numbers for this site. (For more details on how the wraps work, see [Setting up for Electric, Gas, and Water Meters](#)).

Season Dates Available

This field is used to specify the dates that a site is normally available. This information is used for showing what sites are available for a given date and also can be used to generate more accurate reporting. While it's possible to create a reservation that covers dates that are "out of season", you would be warned before doing so. These dates will also show up on the Quick-Info window for sites (seen when double-clicking on a site name in the tab views), and any sites not available due to the season dates (or the special dates below) will be shown in a different color on the Rack (typically gray)

Dates in this field and the other two Special Dates fields can be entered as single dates or as date ranges. You can also enter dates without the year if you want to specify dates that apply the same to every year, but this only applies to the Season Dates, not the Special Dates. If you leave this field blank, it means that the site is available all year long (so there's no need to enter **1/1 to 12/31**, and in fact that could slow the software down slightly).

Note that the dates in these fields will be entered in the "regional" format according to your computer's settings -- for instance, month/day for U.S., and day/month for Canadian, etc. U.S. format is used in the examples.

There is no limit to the number of dates or date ranges you can enter, and the field will scroll as needed. Separate each date range with a comma. A space after the comma is optional (it will be inserted automatically when displayed). The format of a date is fairly flexible as long as it follows the month/day/year convention. Each range should include two dates separated by the word "to". Here are some examples of valid range entries:

1/1 to 9/30, 11/1 to 12/31 (note there are no years, so it applies to every year)
1/2/2002 to 4/3/02 (years can be 2 or 4 digits)
10-5-01, 10-7-01 to 12-31-01 (single dates can be entered, and you can use the dash in a date)

Regardless of the date format you use, it will be changed to a common format (mm/dd/yyyy) after you save the information. If you make a mistake in an entry, it will warn you when you click Save and ask you to fix it.

While you could clear out old date ranges once that year has passed, you may want to leave them so that reporting is still accurate for past years.

Wrap-around seasons -- If the range you want to enter "wraps around" the end of the year, such as December to February, it must be entered in two segments if you don't include the year in the dates. So instead for a season of 12/1 to 2/28, enter it as **12/1 to 12/31, 1/1 to 2/28**.

Special Dates Available

Special Dates Available take precedence over season dates in determining if a site is available. Even if you have specific seasons, there may be times when you want to make some sites available out of season. You could just adjust the Season Dates if you enter the dates for each year separately, but if you use the same Season Dates every year (entered without years, like **3/1 to 9/30**) then you need to enter any exceptions in this field.

The Special Dates Available field follows the same formatting as Season Dates, with the exception that they should always have a year in them. (Otherwise you would be better off adjusting the Season Dates.) They will also show up in the Quick-Info window for sites. It's OK to have dates here that are considered available by the seasons anyway, but it would add work for the software so it's best to avoid overlapping dates. Note that dates can also be made available from the Make Site Available function on the Rack view right-click menu. This field will change accordingly with the added date(s).

Note -- Since this is an *exception* list, you can't just put the normally available dates here -- use the Season Dates field for the normal range. The Special Dates Available list simply overrides "out of season" dates to be available.

Special Dates Unavailable

This is the highest priority of the date fields. If a date is included here, the site will be considered unavailable this date even if the same date is in both of the Dates Available lists above. Use this to make a site unavailable at any time, such as for maintenance. Dates in this list should always have years in them. They will show up in the Quick-Info window for sites, and will show up as a different color on the Rack. Note that dates can also be made unavailable from the Make Site Available function on the Rack view right-click menu. This field will change accordingly with the added date(s).

Days of the Week Available

If these fields are enabled, it allows you to indicate which days of the week the site is available on. (For speed reasons, don't enable these fields unless it's necessary.) The days of the week can be overridden by Special Dates Available or Special Dates Unavailable.

Site is Inactive (disabled)

This flag can be set when you want to completely eliminate a site from being used. This will eliminate it from the Rack, the Quick-Pick drop-down list for New Reservations, and the Occupancy Report. However, any existing past or future reservations with this site will still show up in other historical reports.

This is useful if you have eliminated sites from the campground for an undetermined time, or forever. It's better to set this than to actually delete the site from the database, because it will still be used in reports and reservation histories.

Notes

Notes will show up in the Quick-Info window for sites (double-click on a site name in the tab views), so for instance you could check the notes easily before making a reservation. This is a good place to put warnings or special features of a site, like "gets flooded easily" or "great site for bird-watchers". The notes will also show up as a pop-up tip if the mouse is over the site on a date that the site is unavailable, so you can put information there like "No water service" for sites down for maintenance. While the Notes can't be used for automated site selection, it might be a nice touch to put things here that you want to mention to customers on the phone when they're making a reservation.

Notes will be shown as a single line here, but you can enter multiple line notes as long as you like by clicking the "..." button at the end of the notes entry field. This will open a separate Notes dialog for entering the notes (covered in the *Working with Reservations* section). Any current notes will of course be shown, and the cursor placed at the end so you can begin entering notes immediately. When multi-line notes are displayed as a single line, for instance on the Site Details dialog or in lists, each line break will be shown as a double-backslash (" \\ ").

Work Orders...

This will take you to the Work Order list for the Site, where you can view, add, and manage Work Orders for this particular site.

Journal...

In addition to the single-entry Notes field, you can add any number of Journal entries to a site, which are date/time/operator tagged. This can be used any way you like, for instance to make notes as to why certain changes were made to it. This button opens a list of existing entries and also the adding/editing functions.

Audit Trail...

This button opens the Audit Trail for this particular site, showing a list of all changes made to it (at least as far back as when version 6.0 was installed, since the Audit Trail function did not exist before then).

Taxes Setup

(Accessed through [Maintenance](#) / [Park Setup](#) / [Taxes](#).)

Proper tax calculation and ease of reporting depends greatly on the way your set up your Transaction Categories in the Pick Lists, as well as properly choosing tax categories and properly configuring your Rates and Inventory Items (if the POS option is used), as well as properly entering manual Charges. All of this is discussed below.

Tax Categories

The Taxes setup is a simple dialog showing entry for 5 tax rates. For each rate, simply select a Transaction Category to use for it (each tax rate **must** have its own transaction category), enter the rate, and enter a description if desired (a description is optional, it's only seen on this dialog anyway). Tax rates defined here are used for Rates and also for manually entering taxes on Transaction dialogs.

Important: The Category selected for Taxes should **not** be the category you'll use for the Charges. Don't select "Daily Rate" or "Giftshop" as a tax category, for instance. The Tax category should be a category **only** used for the tax itself, like "Sales Tax" or "GST".

By default, you may see a couple tax rates already defined when you set up your database. Feel free to change these. To disable a tax rate, simply select the "blank" category at the top of the selection drop-down list. Then it will no longer show up wherever tax rates are used.

If you don't have a category set up for each tax rate you need to define, or if you want to rename them to reflect your local taxes, go to the Pick Lists and add appropriate Transaction Categories first. The order or position of the categories in the Transaction Categories pick list doesn't matter. These categories will allow you to create reports showing the amount of each tax collected, and will also allow the Transactions dialog to correctly calculate the tax.

Important -- Once you set up Rates, never change the position of these tax categories. This is because the Rates are defined as being taxable by tax rate number (1, 2, 3, 4 or 5), so if you switch them around then you will have to change every Rate definition. This will also affect Point of Sale transactions and inventory items, so it's best to just never change the positions.

Tax Rate

Here you will just enter the current tax rate. Note that the tax rate is a multiplier, not a percentage. Thus, 6.25% should be entered as **.0625**. If you need to change a tax rate later, see the topic below for **Changing Tax Rates**.

Categories for Charges, Taxable and Non-Taxable

Important -- There is no specific indication or tracking of which of your Transactions Categories (or Charges entered) are taxable vs. non-taxable. Therefore it's very important for proper reporting of taxable sales that you set up appropriate Transaction Categories so that the standard reports can be used to determine the taxable vs non-taxable sales (for each tax rate). If you have not already done so, you should do that before finishing the Taxes setup.

A couple specific examples:

1. If you have a "Store" category, but some store items are taxable and some are not (or some are taxed at a local rate only while others are taxed at the full rate), then you should have separate categories -- for instance "Store - Food" and "Store - Non-food", or "Store - Taxable" and "Store - Non-taxable". Then you can use the appropriate category for each item sold, and they will be reported accordingly. Note also that in the local vs full tax situation, you should have separate Tax Rate entries, one for Local Tax only and one for the full Sales Tax rate.
2. If your location waives taxes for long-term (1 month or more) stays, then you may think all you need to do is have the normal Daily Rate, Weekly Rate and Monthly Rate categories, and tax only the Daily and Weekly Rates. That's a good start, but you also need to be aware that if they don't stay an even number of months then a long-term stay can also include some Weekly and/or Daily charges, which should **not** be taxed in this case. One way to do this is to make sure your Rates Setup has separate Rate definitions to be used for the extra weeks/days for a month-plus reservation, and in that rate definition use either the Monthly Rate category

for the charge (even though it may only be a charge for 1 day), or create a separate Daily Pro-rate category to be used.

Adding Taxes to Charges

So far this discussion on categories is only referring to reporting issues, e.g. for quarterly sales tax reporting (See below for more reporting information). This has nothing to do with the actual tax rate used when the charges are added. The method taxes are determined and/or added depends on how the Charges are added.

1. When adding pre-defined Rates, whether adding through Select Rates or Auto-Rates, taxes are added automatically according to the auto-tax selected in the Rate definitions.
2. If using the Point of Sale option, when adding Inventory items through POS Sales Entry, taxes are added automatically according to the auto-tax selected in the Inventory Item Setup.
3. When adding Charges or Discounts manually, using the Charge button on a Transactions entry dialog, then you will see a list of the tax rates and need to make sure the appropriate tax rates are selected. Some taxes may be automatically selected according to the "Default" options selected in Taxes Setup:

The "Default?" field in the tax definitions indicates which tax or taxes will be selected by default when adding **manual** charges. Note that this doesn't force which tax is used (it can be changed if necessary when making the sale), it simply saves time when adding charges by pre-selecting the tax rates that may be applicable.

If the "Default?" option is checked, you can also click the corresponding Categories button select which Transaction Categories this tax should be the default for. Thus you can specify that a Hotel Tax is the default for your site rental categories, and Sales Tax is the default for merchandise categories. If multiple taxes apply to the same categories, that's fine -- just select the same categories for both. Note that if no categories are selected, then it's assumed to be the default for ALL categories.

4. Finally, you can add Taxes manually in the Transactions dialog, using the Tax button. This is a last resort, if for some reason you notice that taxes were not automatically added when using one of the methods above.

Discounts -- Keep in mind that most Discounts are pre-tax, so those need to be subtracted from the taxable Charges for calculate the amount taxed. Again, if some discounts apply to non-taxed categories, then you can make a separate category for non-taxed discounts. Or better yet, avoid using the generic "Discount" category for discounts and always select the appropriate category when a discount is entered (or set up in a Rate), e.g. use the Daily rate category if it's a discount off of the daily rate.

Reporting

Most businesses need to fill out a quarterly sales tax report for your state (or similar reporting for other taxes). For these reports you need to find the amount of sales tax collected and/or the amount of sales revenue that was taxed.

Assuming that you're using the tax categories and auto-tax calculations as designed and explained above (as opposed to including tax in your prices to make them even dollar amounts), getting the amount of sales tax collected is easy:

- Click on the Transactions tab view.
- Click the "Summary Options" button (if you don't see Summary Options, check the Summarize box first),
- If you report based on when they're collected (paid to you), e.g. Cash-basis, click the "Receipts by Category" button under Quick Reports.
- Otherwise, if you need to report based on when they are charged to the customer (whether paid or not), e.g. Accrual basis, click the "Charges by Category" button.
- Click "Summary Options" again.
- Select the "Quarterly" option in the Summarize period group (or "Monthly", as appropriate).

- Click the "Filter..." button and select the appropriate From and To dates for the quarter or month, then click OK.
- Click OK again.

Along with all other Transaction Categories, this will show the actual amount of tax income for the quarter, for each tax category you use (e.g. Sales Tax, Hotel Tax, etc). However, see below for proper Taxable Sales calculation.

IMPORTANT: Do NOT use the "Taxes by Tax Category" report unless your accounting is accrual-based and tax liability is according to when you take the reservation, or if you're entering (or auto-calculating) charges/taxes only when the customer checks in or pays in full. Like "Charges by Category", "Taxes by Tax Category" reports tax amounts as of when they're entered in Campground Master -- so unless you're using Campground Master in the "recommended" way (entering no charges until the customer checks in and/or pays), this will show taxes sooner than they're due. If your accounting is cash-based and you want to report tax as it's collected (paid), use the "Receipts by Category" report in the procedures above.

Taxable Sales

Now you will need to use the report above get the actual amount of taxable vs non-taxable sales. Campground Master doesn't specifically flag each charge transaction as to whether it's taxable or not, so getting the proper amount of sales depends on how things were set up.

1. Add up the taxable categories -- As explained, this depends on having your Transaction Categories appropriately set up so you can tell exactly which categories are taxable vs non-taxable. Given this proper setup and usage of the categories, you can simply add up the categories for each value.
2. Reverse-calculate it from the tax categories, e.g. "Sales Tax" -- for instance if your tax rate is 5% and the tax collected is \$100, then the amount of taxable sales would be $\$100 / .05 = \2000 .
3. Reverse-calculate it from the sales categories -- If you're including taxes in the sales categories themselves (e.g. if you set up your Rates to include taxes so they are even-dollars amounts, and/or not show taxes separately on receipts), then you will have to calculate it from the total sales in the taxable categories. For instance if total taxable sales is \$2000 and your rate is 5%, then divide by 1.05: $\$2000 / 1.05 = \1904.76 taxable sales.

Note that regardless of the method used, expect a small difference between the expected tax on the taxable sales and the actual tax collected. This is expected due to rounding issues on individual sales. If there is a large difference, however, then it's due to problems with your taxes setup or categories setup, or mistakes in sales entry.

Changing Tax Rates

Any time the tax rate changes, you could just come back here to Taxes Setup and change the rate -- however note that this will take effect immediately, and only for new taxes added from here on. Note that if you're using Auto-rates, this could cause previously-charged reservations to be recalculate at the new tax rate if you do anything with them (including just checking them in), so you would need to disable automatic recalculation for those that should not be affected (in Reservation Details).

However, if you want the new tax to apply to any reservation that **arrives** on a set date (even if they already paid a deposit or you already entered their charges, so it adds the extra tax when they check in), then you would need to add a separate category for the new tax and set up a complete separate set of Rate definitions.

First of all, resist the temptation to just rename or delete the previous tax categories or tax rate entries -- you need those for prior reporting and to keep existing reservations from becoming corrupted. What you need to do is add a new Tax rate, and then enable that for your Rates.

1. Go to Maintenance / Pick Lists / Transaction Categories. Check "Allow editing...", and Add a new record for the new tax rate, e.g. "Sales Tax 2020".
2. Add the new rate as a new tax under Park Setup / Taxes. Don't replace the others, just use the next empty slot. You probably don't want to check the "Default" option until the day it takes effect. This won't affect the Rates, but if you add Charges or Discounts manually, it determines whether that tax option is selected by default -- so change the Default selections only after the new tax rate is in effect.
3. If you also have Rates set up, you need to create new Rates that will apply on the appropriate arrival date. In Rates Setup, select each rate definition that will change (you can use Ctrl-click to select many at once), and click "Copy Selected Rates". Now Edit each rate definition -- in each of the old rates, put the old range like "1/1/18 to 12/31/18" in the Season Dates Applicable field. In each of the new rates, put "1/1/20 to 12/31/20" (and change the "Each" amount of the Charge, etc.). Of course the dates will be different if your Rates already have season dates, adjust accordingly

Note that this will make the new rates apply according to the Reservation's dates (dates of stay), regardless of when they made the reservation. If instead you want to apply the new rates according to when they MAKE the reservation (e.g. existing reservations get the old rate, but anyone calling after a certain date gets the new rate), then a different method is needed. See the newsletter article on Grandfathering rates (see newsletter 39).

4. If you also use the Point of Sale, you will need to go through each and every Inventory Item and select the new rate on the date of change. (You could also take a shortcut and change the old tax rate to the new percentage on that day, but that runs the risk of causing some existing reservations to be recalculated at the new rate, as mentioned above.)

Rates Setup

Overview

Rates are basically a shortcut way of entering multiple transactions with pre-defined categories, descriptions, and dollar amounts (multiplied by the appropriate quantities). Taxes can be automatically applied, and you can specify what kind of quantity multipliers will be needed -- a number of day/weeks/months, or number of sites, or a variable quantity such as number of gallons. The primary use for rates is for site rental rates and add-on charges, but they can also be used for electric, gas and water meter support, merchandise, credits, and anything else for which you want to "memorize" transactions.

Rates Setup Dialog

Start setting up rates by opening the Rates Setup dialog ([Maintenance](#) / [Park Setup](#) / [Rates](#)). This will list any rates already defined (if there are any), with their Rate Type, Rate Code (optional), Rate Name, and a value for Each item. From here you will add or edit rates, delete obsolete rates, and move rates in the list. Moving rates in the list is important because the order that they appear here will be the same order they appear when they are selected when entering transactions (assuming you plan to manually select rates instead of using auto-rates). The order is even more important if automatic rates calculation (auto-rates) is used, in which case the least expensive *per day* should usually be first (e.g. Monthly first, then Weekly, then discounted daily, then the normal single-day rate last).

The Rates Setup dialog starts by showing All Rate Types (all rates defined), but you can select any of the other types to narrow down the list. If you select a specific type here, then that type will be assumed when you add or insert a new rate definition (but the type can be changed later). You can also [Print](#) the shown list at any time.

Adding or Editing Rates

Note that the amounts shown for the rates in the list are coming from the Rate Definitions -- they cannot be changed directly in the list. You need to Edit the rate definition to change an amount. Also note that the amounts do not include taxes, if the Auto-add Tax feature is being used to calculate taxes on the rates. If you see "<EXPR>" for the rate amount, that means that the rate amount is determined by an expression, which cannot be calculated here without proper reservation context.

The basic procedure for defining a Rate is to click Add rate definition, and then enter the details of the rate definition including the applicable site type, discount, taxes, dates, and each of the transactions (charges, etc.) that make up that rate. Insert is the same as Add, except that the rate will be inserted in the list at the current selection point, rather than added to the end of the list. You can edit any of the existing rates by clicking on the rate in the list and selecting Edit rate definition, or you can double-click on the rate in the list.

Warning -- Once a rate is edited or deleted, there is no way to Cancel the operation -- the changes are permanent once you leave the Edit Rate dialog and come back to the Set Up Rates dialog. (Moving rates is also "permanent" since there is no Cancel button, but you can always move them back.)

You can Move, Delete, or Copy one or more rates by selecting the rates in the list (Ctrl-click or Shift-click will select multiple rates), and then click the appropriate button. Copying rates is very handy if you have groups of rates that are similar but have slight variations, such as discounts or season dates.

Add or Remove date(s) to Rates

These functions allow you to select any number of rates, enter one or more dates or date ranges, and will add or remove those dates from the applicable dates for the rates selected. It does so by adjusting the "Special Dates Applicable" or "Special Dates Not Applic." fields of the Rate definition. It won't modify the "Season Dates" setting.

Importing and Exporting Rates

These functions allow copying a rate setup from one database to another (or between computers). This is used if you have your software provider do the setup on another system and then need to import that setup to the working database on your computer. The Import function will **only** work with files exported using the Export Rates function here. It cannot import rates from a user-created file.

The Export function creates a text (CSV) file in a special format that the Import function can read. This can include one or more rate definitions (select the entry or entries to export before clicking the Export button). To complete the export, select the location (Save in) and the file name for the exported file with the "Export" file dialog is shown.

The Import function is simply the reverse of Export -- select the CSV file containing the exported rates, and Open it to import the rates into your database.

Examples!

The following detailed description of rates definitions can get pretty technical, so if you want to just start setting things up then skip to the Rates Setup Examples section below for step-by-step tutorials.

Rate Types

There are several different rate types, and it's important that you select the appropriate type for each rate. This determines how the rate will be used. While these types cannot be changed, you can have as many

different rates of each type as you like. Note that the Rate Type for each rate can be changed later, so you can move them to a different category easily.

Rental Rate -- This is for your basic site rates for daily, weekly, and so on for each Site Type you've defined. Of course if you have sites set up for things like craft halls, bicycles, etc., then those rental rates would also go here. You will likely define separate rental rates for each discount (none, Good Sam, FMCA, etc.), and you can also define the dates that each rate applies to. If you have different rate possibilities for one site type, for instance 30A and 50A service, you can either define these as two separate rental rates or define one base rate with a 50A add-on. The choice may depend on how many different rates you will have (to keep the lists short), or how you want it to appear on the receipts (as one rate charge or as two charges; one for base and one for the add-on).

Add-On -- This is for any extra charges on top of base rental rates, such as for 50A electric, phone, extra people or vehicles, and so on. However if your rate structure is very simple, you may elect to put the add-ons in the Rental Rate section so that they are all listed together, or perhaps just set up separate rental rates for with and without the add-on.

Day Fee -- This was originally for Day Pass reservations, but is now largely obsolete since Day Passes are handled as Rental Rates. This type can be used for other manually-added rates if you like. Examples might be golf course fees and tours. Note that rates of this type will NOT be included in auto-rates, so this type should not be used for Day Pass reservations if you want the charges for day passes to be added automatically.

Electric Meter, Gas Meter and Water Meter -- These are special rate types for meter readings. They are special types because when they are used, a dialog will open up to enter the new reading -- the site information is updated automatically and it will put the meter readings in the transaction descriptions. When defining the transactions for these types, a suggested Description for the charge is something like "Metered kwh:", so it comes out on the receipt like "Metered kwh: (1000-800)". Note that these rate types will always appear in the list when setting up rates, but they will not appear when selecting rates for transactions unless you have sites set up with the appropriate meter type(s) enabled.

Credit -- You can use this rate type for any standard credits that you apply, such as coupons, rain-out credits, etc. You don't need to use this for discounts like Good Sam, since you can define rental rates with the discounts included. You probably also won't use this for refunds, since those can be handled by selecting the appropriate rental rate and applying it as a negative charge.

Merchandise -- This rate type can be used for any non-rental merchandise, such as propane, RV supplies, gift shop items, and so forth.

Miscellaneous -- This is for "anything else" for which you want to memorize transactions. Typical uses would be for standard deposit transactions, cancellation fees, membership cards, tour packages, etc.

Keep in mind that the Rental Rate and Add-On types will be the default rates shown when selecting rates for a transaction, so any rates defined as Rental Rates and Add-Ons will be the quickest to select (any others will require two extra clicks to select the appropriate type from the list). Also, the Merchandise rate type will be automatically shown when selecting rates for an Unbound transaction or Customer transaction.

Edit Rate Definition Dialog

When you select New, Insert, or Edit from Rates Setup, the Edit Rate Definition dialog will appear. This is where you define all of the details of the rate.

Make sure that the desired Rate Type is selected (this can be changed any time), and enter a Rate Code and Description. The Description is shown in the rate selection list, so you should make it simple but also descriptive enough for easy recognition. If this rate is for a discount, for instance, you should indicate that in the description so the correct rate is chosen.

There is also a Rate Code field that's usually disabled by default. This can be used to select rates quickly with the keyboard if you have simple codes for common rates, but has no use in most situations.

Rate Type

There are a fixed set of Rate Types to choose from, and it's important that you select the appropriate type.

The different types were covered in the previous section above.

Rate Transactions

Next is the Transaction Template section. This operates just like the New Transactions dialog, but instead of transaction entry dialogs opening you will use the grid-entry method to enter the data. Add each transaction that you want to appear for this rate, and enter an Each amount (how much for each day, or week, or item, etc.). The Each amount will later be multiplied appropriately.

Typically you will simply enter a Charge transaction here, with the appropriate category, description, quantity (optional) and amount. Note that in some cases the description will be modified later. For instance if the charge is for multiple sites, it may add "(5 days x 2 sites)" to the description. Electric, gas and water meter charges also have their descriptions altered (see the Rate Types explanation above).

If you don't see a Category you want to use for the charge, you can make your own through Maintenance / Pick Lists / Transaction Categories. See that section for details.

You can also add appropriate discounts here. For instance, it's recommended that for a Good Sam rate of \$18, you add a Charge for the standard rate of \$20, and then add a Discount of \$2. This will be more descriptive on the receipt and also allow you to generate reports about the discounts.

Notes on Quantity -- This field should almost always be left blank (which assumes a quantity of 1, multiplied by whatever is necessary like # of days, weeks, etc. as described below). The primary purpose of this field is to have an item that is sold as a bundle, where you want a total quantity to show on the receipts. For instance if it's for a box of 25 candy bars for \$10 instead of single candy bar (perhaps sold at a discount), then you could put 25 in the quantity and the unit price (e.g. \$0.40) in the Each field. The other use for the quantity field is for manually adding specific tax amounts (see below).

Using Calculated Expressions for Transaction Values

NOTE: This is an advanced feature! Using calculated expressions *not recommended* except in very extremely complex situations -- normally the transaction "Each" values will be fixed amounts, where you have multiple rate definitions so the amount charged is determined by which rate definition applies. However if you absolutely need to calculate a value (e.g. for cases where the normal "Applies if..." conditions for rates cannot handle your rate structure), it's possible to use the Advanced Customization functionality of Expressions to calculate the rate. Keep in mind that technical support is not included for using calculated values, as this is a customization/programming function.

Expression for "Each"

To enter a calculated expression for the "Each" value of a transaction, enter an equal sign ("=") in the "Each" column and press the Tab key. This will open the Expression Creator dialog where you can enter the expression. The expression should of course result in a numeric value, which will be used as the Each amount for the rate when it's used for a reservation.

Once an expression is entered, the Each column for the transaction will show "<EXPR>", indicating that a fixed value is not known. To view or edit the expression, click on "<EXPR>" in the Each column to highlight it, and click again to open the Expression Creator (or press the "=" key). If you decide that you don't want it to be an expression, you need to completely clear out the expression in the Expression Creator dialog and click Save. It will change back to blank, so you can enter a fixed amount.

Note that whenever this rate is shown in the Rates Setup list or Select Rates, it will also show <EXPR> as the amount. It can only calculate the expression to determine the actual amount after it's Added in select rates, or when it's automatically added to a reservation.

While the typical use of calculated expressions would be for rental rates or add-on rates, it can also be used for metered rates -- for instance to use a complex formula for electric meter charges. In addition to **ThisResv()** and **ThisCust()** context when calculating the rate, these special context functions are available for rates:

ThisRate() -- The Rate record itself

ThisRateSites() -- The number of sites the rate is being calculated for (if applicable)

ThisRatePeriods() -- The number of days, weeks, etc. the period is being calculated for

ThisRateQtyExtra() -- The "Qty" value, if an extra quantity value is applicable (e.g. for add-ons)

ThisRateQtyTotal() -- The total quantity being calculated for (e.g. sites x periods x extra qty)

These additional functions are used only for Meter reading rates:

ThisRateQtyMeter() -- The number of units being calculated for

ThisRateMeterPrev() -- The previous meter reading

ThisRateMeterNew() -- The new meter reading

ThisRateMeterDatePrev() -- The date of the previous reading (as per Site Details)

ThisRateMeterDate() -- The date of this reading ("Actual date of reading" on the report dialog)

Important -- If the rate is being calculated for multiple synchronized sites, **ThisResv()** could be any one of the synchronized reservations. If you need separate information from each linked reservation (e.g. Site Types), it would be up to you to traverse the linked reservations in the expression.

Expression for "Qty"

You can also enter an expression for Qty, by entering an "=" as described above. Note that an expression here will completely override the normal rate multiplier of sites, periods, and other quantity (e.g. for add-ons or meters). Thus the context functions need to be used if the qty should take those into account.

Expression for "Description"

You can enter the description as an expression also, for instance to include information from the customer or reservation in the description. As with the Each and Qty, starting the description with an "=" will denote it as an expression -- however the expression builder is not opened in this case. You can enter the expression manually in the line, or build it elsewhere and paste it here (using normal copy/paste). Just be sure it still has the "=" at the beginning, with no space after the "=". For example, to show the reservation type as the description, it would be shown as:

```
=Resv:Resv_Type
```

Taxes

Important -- Although you can add Tax transactions manually, it's recommended that you use the Auto-add tax check boxes instead. Otherwise you will have to edit every rate definition any time the tax rates change.

Assuming you don't add the tax manually (see below), simply check the appropriate Auto-add tax boxes. There is one box for each of the 5 possible Tax Rate definitions, but only those that are active according to Taxes Setup will be enabled (and they will show the selected category name for the tax). When you check these boxes, the With Tax amount is automatically calculated.

One exception to using the auto-add option would be for special cases where the tax does not apply to the total charges less discounts. For instance, if you add a Discount to the rate as mentioned above, the Discount transaction would be taken into account for taxes. Therefore you would have to add the tax as a separate transaction and not use the Auto-add tax feature if the Discount should not reduce the tax (though this would be unusual).

Another exception would be if you want your rates to be "rounded" after tax, such that exact calculations are difficult without rounding problems. For instance, if your daily rate is \$23.00 but that already includes a 10% tax (roughly. \$20.9091 + \$2.09091 tax), then it may be easiest to enter Charge and Tax transactions separately so it always comes out exactly \$23.00 per day.

When adding Tax transactions manually, it's a good idea to use the Quantity field -- which for taxes is actually the amount to be taxed. This results in more accurate tax reporting, as well as a meaningful note on receipts. So for the example above, the Charge for the rate would have an Each value of \$20.9091. Then you would enter a Tax transaction with a Qty of 20.9091 (the amount taxed) and an Each of \$0.10 (which means 10%). This rounds out to an even \$23.00 no matter how many days are added, and the amount taxed will also be accurate.

Multipliers and Filtering

This is the most important part of the setup, especially for auto-rates, but also affects Select Rates.

The rest of the dialog entries are used to "qualify" a rate. This determines whether the rate definition applies to any given reservation, so it's important to get this set up properly. Otherwise, the rate may not appear in the Select Rates list, or too many rates will show up that don't all really apply to the reservation. Likewise, it's essential that the correct filtering is used for auto-rates, so the program can automatically figure out which rate to apply to each reservation.

The filtering is most important to Rental Rate and Add-On rate types, but it is used for other types as well (for example, you can filter a Merchandise rate so it only shows up for a particular Reservation Type).

If the rate is for any kind of merchandise or other item that may have more than one quantity *other than periods or sites*, make sure that Ask for other quantity is checked. That way a Qty entry field will appear when you select this rate. But you should **not** check this option for Rental Rates in most cases.

Rate is per... and Multiply-by options

To have a rate multiplied by the number of days, weeks, etc. in the reservation, fill in the Rate is per field and select a period from the (# of) drop-down list (Days, Weeks, Months, or Years). Also be sure to check the Multiply by # of periods check box for any per-period type of rate.

Note that if you've set up any "schedules" for intra-day reservations, for instance hourly reservations, those schedule names will be added to the Rate is per list. If the rate is for one of those scheduled sites, select the appropriate schedule name instead of Day, etc. When a schedule is selected, an additional Periods button and field will be shown where you can select specific periods that the rate will apply to.

For most rental rates you will also want to check the box for Multiply by the # of sites. This is important when using linked reservations (e.g. if they reserve more than one site for the same time period).

Applies for a maximum of ... periods

For rates that are multiplied by the # of periods, you can also specify that the rate applies for a maximum # of periods. Enter a number in that box to limit the # of periods (e.g. # of days) that this rate should apply for (if the reservation is longer, it will only use this rate for that number of periods, and look for other rates to fill the rest of the time). For instance if you accept Passport America discounts for only 2 days, set up the P.A. discount rate to apply for a maximum of 2 days. The rest of their stay will then be charged at the normal rate (using the next applicable rate in the list). This should **not** be set for most rates -- leave it blank unless it's a special limited-period rate!

"Applies only to..." Filtering

This is the most important part of the setup.

The rest of the dialog entries are used to "qualify" a rate. This determines whether the rate applies to any given reservation, so it's important to get this set up properly.

Resv Types

You will need to select one or more Reservation Types for which the rate applies. Click the Resv Types button to open a list of reservation types, and select any that are applicable. For instance, you may have different rates for Monthly reservations than your Normal reservations. Typically you may not have any rates that apply to Free Stay types, except perhaps utility (meter) rates. Guest reservations might have rates defined that are essentially an extra vehicle charge, and Day Pass reservations may have a day-use rate defined.

Site Types, Site Classes, or Sites

If this rate only applies to certain Site Types, click the Site Types button and select the applicable types from the list that appears. If no site type is selected, the rate will show up for reservations of any site type (assuming other filters don't exclude it). If you select one or more site types here, then that rate will only show up when a reservation is for one of those site types (or has a synchronized reservation of that type).

Likewise, you can have a rate apply to specific Site Classes, using the Site Classes button, or even one or more specific sites using the Sites button. However you don't need to set all three (types, classes, and sites) -- usually only one of these selections is enough to sufficiently qualify the rate. For instance if you select "Normal RV" for the Site Type, there's no need to select "RV's" for the site class because it's redundant -- all "Normal RV" sites will have an "RV's" class anyway, so there's no need to make the rate check this too.

Discounts

If you offer discounts, such as Senior discounts or Good Sam membership discounts, then you will need to set up multiple rate definitions -- one "normal" rate that applies to no discounts, and a separate rate definition for each discount category (or at least one for each different discount amount). Filter each rate definition for the appropriate discount by either selecting one or more discounts from the Discounts list, or by checking the Only applies if no discount used check box. As with Site Type, this will determine whether the rate will appear in the rate selection list for a given reservation.

Note that if a rate applies to more than one discount, you may need to set it up so that the appropriate discount shows in the charges after the rates is applied. To do this, blank out the Description for any Discount transaction entries. It will then be filled in with the current discount selected on the Transactions dialog.

Ask for other quantity

The Ask for other quantity check box can be checked for any rate, which will allow a separate quantity entry field to appear when the rate is selected. Generally this is not used for rental rates, but it can be used for Add-On rates like extra people or vehicles, and for any other kind of rate.

Exclude from auto-rates

If you're using the auto-rates functionality, all Rental Rates and Add-On rates will be used in the auto-calculations unless individually excluded (other Rate Types are never used for auto-calculation, so this field wouldn't affect them). To exclude a rate from auto-rates calculations (e.g. for a manually added charge), check the Exclude from auto-rates calculations option.

Meter Reading Rates

The Ask for meter reading check box should be selected for any meter-reading rates where it will be multiplied by the metered amount (e.g. kwh for electric meters.) This is used as a flag for the special meter-entry dialog. If this option is selected, a Meter Allowance field will also appear. If your rental rates include a certain amount of electricity, water, or gas and then you charge for excess, then enter the allowance here. This will adjust meter charges accordingly -- the actual meter readings will show on the receipt, but the charge will only include units above the allowance.

For any of the Meter rate types, you can also enter values for Applies if >= units and Applies if <= units. This allows different meter rates to be used for different amounts of usage, such as for tiered meter rates.

Applies if ... days

You can set up the rate to apply only if the reservation is longer or shorter than a given number of days, by setting the Applies if >= days and Applies if <= days fields. For instance, there's no reason to show monthly rates if the reservation is less than 20 days or so. In this case, you would want to base the days on how many days it would take for the monthly rate to be more economical than the weekly rate, for instance. This could also be used for "3-day special" rates, etc., to show the rate only if they are staying more than 3 days.

Be careful about setting the maximum days, however. It may seem appropriate to set the daily rate to only show if they're staying less than 7 days, but then if they stay 10 days you would not be able to apply the daily rate to the remaining days. This should only be done in special circumstances, for instance if you have 2 different daily rates -- one for short-term stays and another for pro-rating long-term residents.

Applies if reservation field...

The Applies if reservation field... selection permits a great deal of control over when a rate is used. This specifies that the rate applies to a particular "preference" setting in the reservation or one of the "# of" or value fields such as number of adults, extra vehicles, or rig length. This option is most often used for add-on rates, such as for adding \$1.00 per extra person, but can also be used to indicate a special rate if they need 50A service, for instance.

To use this option, select a reservation field from the list. Some numeric fields are also available in additive combinations also, primarily to allow "# Adults + # Children" to be selected if you charge per person regardless of age.

If the field is an attribute/preference field, such as "50A", then you can specify whether the rate will apply only if that preference is "true" (set to "Must Have") for the reservation, or whether it's "False" (not set or set to "Must Not Have" are both considered false in this case). Therefore you can set up two separate rates that are mutually exclusive, one for the True case and one for the False case of the preference field.

If the field is a numeric value, additional settings will appear that need to be entered. You will first enter a value for "is >=" to indicate when the rate applies. For instance, if you charge for any adults *above* 2, then set this value to 3. Next you can specify that the rate is "Per each more than", which means that it will be multiplied by the value minus some number. For instance, set this value to 2 in the previous example to charge for every adult above 2 adults. Another example would be a charge for all extra vehicles -- set "is >=" to 1, and "Per each more than" to 0.

Adding new fields -- If you need add your own fields for use in rates like this, then note that they must be tagged as "Attrib" fields in order to be selectable from this list. See the special note about Attribute Fields under the **Adding New Fields** section of the Data Field Definitions topic.

Advanced Condition Expression...

If the rate can't be properly qualified using the other Applies-if conditions, date selections, etc, then you can use Expressions to create a condition as complex as needed. Note that this involves the Advanced Customizations functionality and is only recommended for very technical users, so refer to that section for more detailed information.

If a Condition Expression is entered here, it must be satisfied (result in True) in addition to all other conditions in the rate definition in order for the rate to be used. Thus you can use the other Applies-if conditions to handle the simple stuff, and use the expression to only do the filtering that can't be otherwise handled by the rate definition.

While it's possible to use a condition for any type of rate whether it's for a reservation or not, e.g. for merchandise, it will not have any context to work with unless it's for a reservation. When the rate is for a reservation, it will have **ThisResv()** context which will the specific reservation being calculated (e.g. if there are 5 synchronize reservations being calculated, this expression will be executed for each reservation individually). In addition, **ThisFromDate()** and **ThisToDate()** will indicate the date range being qualified (as well as **ThisFromPeriod()** and **ThisToPeriod()** if it's an hourly/scheduled reservation). Note that this will be the entire date/period range of the reservation when qualifying the rate for Select Rates, but when actually auto-calculating rates it will be a single day (or period), as the rate is checked for applying to each day or period individually.

Rate Dates

You can define the dates for which any rate is applicable. This will be used whenever selecting a rate for a reservation, and will only show the rates that are applicable on at least one day of the reservation. For instance, if a reservation includes a holiday, you will see both the normal rate and the holiday rate in the selection list. Likewise, when you select the holiday rate, the quantity that appears for the number of days will be just the number of days that the reservation date occurs on the rate's applicable dates.

For example, if the reservation is for 5 days and includes 3 holiday days (e.g. for a holiday weekend rate), then the holiday rate will be multiplied by 3 days and the normal rate will be multiplied by 2 days (assuming the rate's dates are defined to be mutually exclusive). Although you will have to select both rates, the numbers will be handled for you automatically.

Defining dates for a Rate definition is just like defining dates that a Site is available.

Season Dates Applicable

This field is used to specify the dates for which the rate is applicable. Dates in this field and the other two Special Dates fields can be entered as single dates or as date ranges. You can also enter dates without the year if you want to specify dates that apply the same to every year, but this only applies to the Season Dates, not the Special Dates. If you leave this field blank, it means that the rate is applicable all year long (so there's no need to enter **1/1 to 12/31**).

Note that the dates in these fields will be entered in the "regional" format according to your computer's settings -- for instance, month/day for U.S., and day/month for Canadian, etc. U.S. format is used in the examples.

There is no limit to the number of dates or date ranges you can enter, and the field will scroll as needed. Separate each date range with a comma. A space after the comma is optional (it will be inserted automatically when displayed). The format of a date is fairly flexible as long as it follows the month/day/year convention. Each range should include two dates separated by the word "to". Here are some examples of valid range entries:

1/1 to 9/30, 11/1 to 12/31 (note there are no years, so it applies to every year)
1/2/2018 to 4/3/18 (years can be 2 or 4 digits)
10-5-19, 10-7-19 to 12-31-19 (single dates can be entered, and you can use the dash in a date)

Regardless of the date format you use, it will be changed to a common format (like mm/dd/yyyy) after you save the information. If you make a mistake in an entry, it will warn you when you click Save and ask you to fix it.

You can clear out old date ranges once that year has passed (and add new ones for upcoming years). Unlike the dates for Sites, there is no need to keep old dates in the lists since you probably won't be adding transactions to old reservations.

Wrap-around seasons -- If the range you want to enter "wraps around" the end of the year, such as December to February, it must be entered in two segments if you don't include the year in the dates. So instead for a season of 12/1 to 2/28, enter it as **12/1 to 12/31, 1/1 to 2/28**.

Important -- When defining rates for different seasons, make sure that there are no gaps or else there may be times when no rates appear (or they don't multiply by the correct number of dates). Likewise it's a good idea to avoid overlapping. Therefore if you have a special holiday rate with a Season Date of **7/4**, then your normal rate definition should have **7/4** in its Special Dates Not Applicable Field to exclude that date from the normal rate.

Special Dates Applicable

Special Dates Applicable take precedence over season dates in determining if a rate is applicable. Even if you have specific seasons, there may be times when you want to make some rates applicable out of season. You could just adjust the Season Dates if you enter the dates for each year separately, but if you use the same Season Dates every year (entered without years, like **3/1 to 9/30**) then you need to enter any exceptions in this field.

The Special Dates Applicable field follows the same formatting as Season Dates, with the exception that they should always have a year in them. (Otherwise you would be better off adjusting the Season Dates.) It's OK to have dates here that are considered applicable by the season dates anyway, but it would add work for the software so it's best to avoid overlapping dates.

Note -- Since this is an *exception* list, you can't just put the normally applicable dates here -- use the Season Dates field for the normal range. The Special Dates Applicable list simply overrides "out of season" dates to be applicable.

Special Dates Not Applicable

This is the highest priority of the date fields. If a date is included here, the rate will be considered not applicable on this date even if the same date is in both of the Dates Applicable lists above. Dates in this list should always have years in them.

Days of the Week Applicable

These checkboxes allow you to indicate which days of the week the rate is applicable on, which is handy for specifying weekday / weekend rates. Note that the days of the week selected can be overridden by Special Dates Applicable or Special Dates Not Applicable, so take care in specifying special dates in these cases.

Notes

The Notes field is just for your own notes, perhaps an explanation of why a rate is set up the way it is. The Notes are never seen by the customer or by an operator selecting a rate. The notes can be any length.

Auto-Rates Setup

Auto-rates calculation can be very powerful, but some care is needed to set it up properly. It can completely alleviate the need to use the "Select Rates" or "Charge" functions except for special cases, and can help eliminate errors in selecting appropriate rates. Auto-rates functionality is based on your Rates definitions, so it's important to set up your rates properly to avoid multiple or inappropriate rate calculations.

Auto-rates can be used to fully automate charges (by automatically applying them upon reservation creation or check-in), or for semi-automatic functionality using the "Auto-Calculate Rate Charges" button on the Transactions or Select Rates dialog.

Basic Auto-Rates Configuration

For basic auto-rates configuration, see Maintenance / Program Options / Auto-Rates. Here you enable/disable the auto-rates functionality, specify whether it attempts to find "better" rates than strict rate selection (e.g. select the weekly rate if they stay 6 days, if that's cheaper), define how re-calculated rates are applied, and define when auto-rates are applied and re-calculated.

The recommended setup is to configure it to auto-calculate rates on Check-in, so charges don't have to be changed or backed out when the reservation is changed before check-in or canceled. This also helps with transaction reports, so charges are reported on the same day that the payment is received for them.

You should also check the box to enable auto-calculation for the Check Rates and Quote/Confirmation functions. These functions can be used to tell the customer what the total will be without actually adding the charges to the reservation, so there is really no need to add charges before the reservation is checked in.

Rates Definition Rules

Proper definition and arrangement of the rates is essential for auto-rates to work correctly.

There are several rules that need to be followed when defining rates so that they work properly with auto-rates. The main thing to keep in mind is that the rates will be applied top-down (according to the list in Rates Setup) until the reservation is "covered". This is explained in more detail in the next section, [Auto-rates proper order example](#).

All of the rate filtering is used, and it won't apply a rate that would cover dates that aren't in the reservation or have been covered by a previously applied rate. (Exception -- if you set it up to apply to longer periods to find a better rate, it will apply rates assuming the reservation is longer than it really is to see if a cheaper rate would apply.)

Auto-rates can also be set up for add-ons like 50A electric, pull-through, extra adults, vehicles, and so forth. This is done using the "Applies if field..." selection in the rates definition.

The two most common causes of rates not working properly are the **order in the list** and the **"Applies only to"** filtering in the rate definitions. Please pay attention to these items. If the order isn't correct in the Rates Setup list, it could apply the wrong rate. If the filtering isn't correct, it might not apply any rate, or will apply the wrong one. It's common to set up the filtering to exclude too much, for instance setting a Discount when the rate should apply to non-discounted reservations, or using the "Applies if <= ____ days" setting when it really shouldn't be used.

Here are the basic rules:

- Rates will be applied top-down (see the next section, "Auto-Rates proper order example", for more detail). When adding a rate, think about whether it should take precedence over any rates listed above it (e.g. weekly takes precedence over daily, discounts, date-specific and site-specific rates takes precedence over the normal/default daily rate, etc.).
- Only Rental Rates and Add-On rate types will be used for auto-calculations.
- Put longer-term rates above shorter-term (e.g. so a weekly rate is applied instead of a daily rate for 7 days).
- Try to make rates mutually exclusive, so for instance only one daily rate would apply for any given site, discount, and date. If this is not practical, make sure all qualified rates are above the generic (default) rates so they get applied first if appropriate.
- Put discount rates above non-discount (if they aren't completely mutually exclusive by the definitions), so that the normal rate only gets used if none of the discounts apply.
- For monthly pro-rate daily rates, make sure the ">= ____ days" field is set properly to avoid applying pro-rates to reservations less than a month long. (Also be sure to set the <= option for non-pro-rate daily rates, or make sure the pro-rate rates are above the normal daily rates).
- If you pro-rate by the actual number of days in the month, have separate pro-rate rates (for 28, 29, 30 and 31 days) with season dates set appropriately.
- If a rate shouldn't be used for auto-rates (including monthly billing) , set the "Exclude from auto-rate calculations" flag.

Warning -- reservations without a site assigned will probably use the first rate definition by default (since no site type/class is available for filtering). Obviously the reservation can't be checked in until a site is assigned, but this will affect the Quote/Confirmation, as well as if the Auto-calculate function is used on the Transactions dialog. If unassigned reservations are "allowed" for your park, it may be a good idea to have "dummy" rate at the top that could not apply to any normal reservations. Make it something like \$.01 per day, and apply to a site type/class combination that's normally impossible (e.g. an "rv" site type and "boat" site class).

For further information on using auto-rates, see the Auto-Rates section in *Working with Transactions*.

Auto-Rates Troubleshooting Notes

When you try to auto-calculate a reservation, one of 3 things usually happens:

1. It adds the correct rates (congratulations!)
2. It doesn't add any rate. This typically means that the rate you want to add is "over qualified" -- i.e. there is something selected in the definition that is inconsistent with the reservation (e.g. a Discount is selected but the rate isn't the discounted rate), or is too specific (e.g. the Normal RV Site Type is selected but the rate should apply to all types or a different Site Type). Edit the Rate and review all of the selections below "Applies only to...".
3. It adds the wrong rate. So...
 - If the incorrect rate being added appears ABOVE the correct one in the list, then that means the one it's using is applying to the reservation when it shouldn't -- e.g. it doesn't have the correct things selected under "Applies only to"... e.g. it's not filtering the sites correctly (maybe it has nothing selected so it applies to all, or has the wrong sites selected), or perhaps isn't filtering out the dates it should. It could also be that the order is incorrect, e.g. you have a more general rate above the more specific rate (see the proper order examples below). So focus on the one that is being applied by mistake, since that's where the error is.
 - If the incorrect rate it's adding appears BELOW the correct one, then the problem is with the one it should be using. In other words, it's going past the correct one without thinking that it applies to the reservation. See #2 above.

Auto-Rates proper order example

One of common issues in getting Auto-Rates to work is the order of the Rates. While it's natural to want to put Daily first, then Weekly, etc, when entering the rates, that's actually the opposite of what the program needs and will result in Auto-rates wanting to charge the daily rate for all reservations.

As explained in the Auto-Rates rules, the program looks top-down for the first/best matching rate, and will use the first one it finds that can "apply to" the reservation. So the "cheapest per day" rate is usually first, as well as any "special case" rates you need to override a normal rate like holidays or higher season rates.

Here is a typical order for proper operation, given a common situation of 2 different seasons, a daily discount rate and a special holiday daily rate:

- Monthly high season
- Monthly low season
- Weekly high season
- Weekly low season
- Holiday daily
- Discount daily high season
- Discount daily low season
- Normal daily high season
- Normal daily low season

Note that they are essentially in order of priority, so you can "read" them like an "if.... then... otherwise..." structure. For instance:

- If it's a month or more in high season, then use the Monthly high rate....otherwise,
- If it's a month or more in low season, then use the Monthly low rate....otherwise,
(... skipping high/low from here on for simplicity ...)
- if it's a week or more, then use the Weekly rate.... otherwise,
- if it's a on holiday, then use the Holiday rate... otherwise,
- If they have a discount, then use the discount rate.... otherwise,
- use the normal daily rate.

This is basically what the program does, so once you understand how that works then it should make a lot more sense.

Other notes:

If there are "leftover" dates after the first pass through, then it repeats again for the remainder. For instance if the reservation is for 1 month plus 17 days, then it will use the Monthly rate, then go through again for the other 17days... it will find that the Weekly rate can be used twice, then go through again for the remaining 3 days and use the appropriate Daily rate.

Of course all of this would need to be replicated for each Site Type, etc.

It doesn't matter if you group them with all Cabins together and then all RV's together, etc, or whether you put Monthly for all site types first, then Weekly for all site types, etc. -- as long as the rates themselves are properly qualified with the Site Type selection , etc.

Note that the high vs low season order doesn't matter, as long as **both** are properly qualified with Season Dates Applicable.

Likewise, the Discount rates, Holiday rate, etc need to be properly qualified so that they only apply when they're applicable (see Rate Setup Examples).

A lot of other situations can be handled similarly, for instance weekend vs weekdays in place of the "Normal" daily rates, etc.

Rate Setup Examples

Here are some step-by-step examples to get you started setting up your own rates. For technical details refer to the previous sections.

The examples below assume you still have the default pick lists, as seen in the demo or a new database -- naturally if you've changed the pick lists for Transaction Categories, Site Types, or Discounts, or if you've changed the available Reservation Attributes, then your choices may be different. Actually we recommend changing those Pick Lists to reflect your needs -- so do that first before setting up your rates. In particular, check the Transaction Categories pick list to see if it covers all of the things you need (e.g. you may want separate categories for RV rent vs. Cabin rent, or you may need to add a Seasonal category, etc.)

For each example, it's assumed that you're already in Maintenance / Park Setup / Rates.

Basic Daily Rate

To set up a \$20.00 per day rate for Normal RV sites:

1. Click Add rate definition.
2. Enter "Basic daily rate, Normal RV" in the Description field.
3. Click the Charge button.
4. Select (click on) "Daily Rate" from the drop-down category list.
5. Press the **Tab** key to change to the Description field, and change it if you want (e.g. "Normal RV, daily"). You can just start typing to replace it entirely, or press F2 to enter editing mode. The Description is what will show on the customer's receipt.
6. Press the **Tab** key twice to get to the Each field (no Qty is necessary).
7. Enter the daily amount, not including taxes, for instance "20". No dollar sign or decimals are needed (assuming it's a round dollar amount)
8. Press the **Tab** key to accept the amount.
9. Check the boxes for one or more taxes under Auto-add tax, if they apply.
10. Select "Days" from the drop-down list after Rate is per 1 (# of).
11. Verify that the Resv Types shown is "Normal, Group, Monthly" and that the boxes are checked by Multiply by # periods and Multiply by # sites. These are the defaults and will probably be correct unless you have special cases.
12. Click the Site Types button, select "Normal RV" from the list, and click OK.
13. Click the Save button -- you're done with your first rate!

This shows how to set up a rate for a single site type, "Normal RV". You probably need to set up separate rate definitions for each of your site types, or at least each group of site types for which you charge one rate (if you charge the same for 2 or more types, then simply include all of those types in step 12 above). Repeat each of the steps above for each of your site types or rate groupings (likewise for other rates below) . This can quickly turn into a large list of rates, but that's normal. It's tedious, but not difficult -- especially using the Copy function as described below.

Weekly and Monthly Rates

To set up a weekly rate of \$120 (for instance if they get the 7th day free, you would simply charge them for 6 days on a weekly stay):

1. Make sure the daily rate added above is selected, and click Copy Selected Rate(s). This will make a duplicate rate definition so we don't have to do everything over again.
2. Select the new copy (click to highlight it), then click Edit rate definition. (Or you can just double-click on it to edit it.)
3. Change the Description field to "Basic weekly rate, Normal RV".
4. Select (click on) "Daily Rate" under the Category for the charge, then click on the drop-down arrow and select "Weekly Rate".
5. Press the Tab key to change to the Description field, and change it if you want (e.g. "Normal RV, weekly").
6. Press the Tab key twice to get to the Each field.
7. Enter the weekly amount, not including taxes, for instance "120". No dollar sign or decimals are needed (assuming it's a round dollar amount)
8. Press the Tab key to accept the amount.
9. Select "Weeks" from the drop-down list after Rate is per 1 (# of).
10. Everything else is the same, so click the Save button.
11. This rate should still be highlighted in the rates list, so click the Move Up button so that it's above the daily rate. This is important so the weekly rate takes precedence over the daily rate. If they stay extra days, it will use the daily rate for the additional days.

To set up a monthly rate, follow the same steps above, substituting the appropriate descriptions, category, and amount, and select "Monthly" in the Rate is per... field. Or if you charge per 30 days instead of calendar months, enter it as Rate is per "30" (# of) "Days".

Then in the last step, move it twice so it's above the weekly rate. Again, the monthly rate will be used first, then the weekly for extra weeks, and/or the daily rate for extra days.

Monthly Pro-rate

If you pro-rate the days when they stay a month or more, then you wouldn't want it to use the weekly and daily rates as mentioned above. So to add a fixed amount per day when they stay 1 month (we'll assume 30 days) or more:

1. Make sure the Basic daily rate is selected, and click Copy Selected Rate(s).
2. Select the new copy (click to highlight it), then click Edit rate definition. (Or you can just double-click on it to edit it.)
3. Change the Description field to "Daily pro-rate, Normal RV".
4. Select (click on) the Description field, and change it to "Normal RV, daily pro-rate".
5. Press the Tab key twice to get to the Each field, and enter the amount (e.g. "10").

6. Press the Tab key to accept the amount.
7. Enter "31" in the Applies if >= Days field. This will force this rate to be skipped unless they're staying more than 30 days (see below).
8. Everything else is the same, so click the Save button.
9. This rate should still be highlighted in the rates list, so click the Move Up button until it's above the weekly rate but below the Monthly rate. This is important so the monthly rate takes precedence, and if they stay extra days it will use this rate for the additional days instead of the normal weekly or daily rate.

Note that we're using 30 days as the definition of a month here, so technically this would only work correctly if you defined your monthly rate to always be for 30 days instead of a calendar month. It would also work OK for calendar months as long as you still want to charge a fixed amount per day for extra days (regardless of the length of the month), except for February, because it will skip this rate if they stay 29 days (Feb 1st to March 1st).

If you use calendar months for your monthly rate, then you will need to set up a separate pro-rated rate for February. You would duplicate this rate, change the Applies-if days to 29, and enter "3/1 to 3/30" in the Season dates applicable field. Why enter March dates? Because if they stayed the full month of February, the extra days would be in March so this rate must apply to those days, not the February days. Note that if they stay the full month of March, it would apply the monthly rate for March anyway.

Alternatively, you may want to use a pro-rated amount that's based on the number of days in the month -- e.g. for a 31-day month, divide the monthly rate by 31 instead of 30. In this case you'll need to create 3 separate Rate definitions for 28, 30, and 31 day pro-rates. In each one, you'll need to set the Season Dates Applicable field for the dates that rate applies to (e.g. "2/1 to 2/28" for the 28-day month pro-rate, "1/1 to 1/31, 3/1 to 3/31, 5/1 to 5/31, 7/1 to 7/31....", etc for the 31-day months, and so on).

Add-on for 50A service

To set up a \$2.00 per day extra charge for all RV sites (not just Normal RV):

1. Click Add rate definition.
2. Select "Add-On" in the Rate Type field.
3. Enter "Add-on for 50A" in the Description field.
4. Click the Charge button.
5. Select (click on) "Electricity" from the drop-down category list. (You might want to add a more appropriate category for this, which would be done in Maintenance / Pick Lists / Transaction Categories).
6. Press the **Tab** key to change to the Description field, and change it if you want (e.g. "50A service, daily").
7. Press the **Tab** key twice to get to the Each field (no Qty is necessary).
8. Enter the daily amount, not including taxes, for instance "2".
9. Press the **Tab** key to accept the amount.
10. Check the boxes for one or more taxes under Auto-add tax, if they apply.
11. Select "Days" from the drop-down list after Rate is per 1 (# of).

12. Verify that the Resv Types shown is "Normal, Group, Monthly" and that the boxes are checked by Multiply by # periods and Multiply by # sites.

13. Click the Site Classes button, select "RV's" from the list, and click OK. Note we're simply selecting the RV site class, not a site type. You could have selected multiple Site Types if you preferred.

14. Select "50A" from the Applies if reservation field drop-down list. Additional fields will appear, and in this case we just keep the default "True" selection.

15. Click the Save button.

The key items in this rate are the fact that it's an Add-on (so it can be added to the rental rate), and the 50A selection so the program knows that it only applies if you've selected that option on the reservation.

Add-on for Extra Adults

To set up an add-on charge of \$3 per extra adult after the first 2 adults:

This will be another add-on rate, so follow the first 13 steps from the add-on rate above (with appropriate changes in the description, category) and for the Each amount enter the \$3 amount per extra adult. You might select different Site Classes also, for instance if the additional adults charge also counts for cabins and tents.

In step 14, select "# Adults" for the Applies if reservation field. Since this is a numeric field, different options will appear. Enter "3" for is ≥ entry, check the Per each more than box, and enter "2" after that. Thus if they have 3 or more adults, it will charge \$3 for each one except for the first 2.

Extra Children or Extra People

You can create another rate like the one above for extra children, if you have separate allowances for adults vs. children or if you charge a different amount for each. However if you just charge per person, and allow for instance 4 people regardless of whether they're adult or children and charge a fixed amount per each person above that, then you can simply select the combination "# Children + # Adults" in the rate above (or it may show the other way around, "# Adults + # Children").

Discount for Good Sam

If you give discounts for organizations like Good Sam, you need to set up completely separate rate definitions that apply to the selected discounts. So first you need to make sure the discounts you accept are in the Discounts Pick List (Maintenance / Pick Lists / Discounts).

There are a couple ways you can set up discount rates, depending on how you want the customer's receipt to show it -- either as a separate line item showing the discount amount, or simply as a reduced amount for the basic charge. We recommend separate line items, not only for the customer's benefit, but because this also allows you to see the discounts on transaction reports.

For now we'll assume that the Good Sam discount only applies to the daily rate (since a discount is already built into weekly and monthly rates).

To set up a Good Sam rate of 10% off:

1. Make sure the basic daily rate is selected, and click Copy Selected Rate(s).
2. Select the new copy, then click Edit rate definition.
3. Change the Description field to "Good Sam daily rate, Normal RV".

4. Click the Discount button (the one next to Charge), to add a discount transaction.
5. Select "Daily Rate" from the drop-down category list. You could leave this as "Discount", or you could set up a specific category, but in this case assume we want to include it in the Daily Rate category for accounting reasons (it will simply reduce the total income shown for the Daily Rate category). We'll still be able to get a report showing the discount amounts if we want, because the Type is Discount.
6. Press the **Tab** key to change to the Description field, and change it if you want (e.g. "Good Sam 10% discount").
7. Press the **Tab** key twice to get to the Each field (no Qty is necessary).
8. Enter the daily amount of discount, not including taxes. We can't enter a percentage, but we know the amount will be \$2 because we know the normal rate is \$20, so just enter "2".
9. Press the **Tab** key to accept the amount.
10. Click the Discounts button (the one below Sites), select "Good Sam" from the list, and click OK.
11. Everything else is the same, so click the Save button.
12. This rate should still be highlighted in the rates list, so click the Move Up button so that it's above the Basic daily rate, but below the basic weekly rate. This is important so the weekly rate takes precedence over the discounted daily rate, but the discount rate will be applied if you select Good Sam as the discount used for the reservation. Otherwise it will skip this one and use the basic daily rate.

If you offer more than one type of discount, you would repeat the above process for each discount you offer. You would also repeat this for any Add-on rates that the discount should apply to -- so you might end up with many copies of daily rates and add-on rates, one for each type of discount.

However there's a shortcut if you offer the same amount of discount, e.g. 10%, for several different organizations. Make the following changes in the steps to make one rate apply to multiple discount types:

In step 6, make the description "Discount". When the program sees that the description is the same as the Type, it will add the discount type on the receipts and it will show up like "Discount : Good Sam".

In step 10, select as many different discount types as needed (hold the **Ctrl** key down when clicking to select more than one).

Now you have one rate that will apply to multiple discounts.

Weekend vs. Weekday Rates

Setting up separate rates for weekdays and weekends is very simple. It's just a matter of setting up two separate daily rates and selecting the appropriate days of the week for each one. Of course this could be expanded to a separate rate for each day of the week if needed.

First you need to make sure the Rates fields for the days of the week are all enabled. If you don't see the checkboxes for them at the bottom of the window when you edit a rate, they've been disabled -- go to Maintenance / Data Field Definitions / Rate Fields, and enable the "Unavailable.." fields for the days of the week.

When you set up the daily rate for weekdays, just remove the check marks from the days of the week that the rate should not apply to. Keep in mind that these are actually "nights", not "days" -- so if the weekday rate should apply to Sunday night through Thursday night, uncheck the Fri and Sat boxes.

Copy that rate, edit it to change the descriptions and amount accordingly for weekends, and now uncheck all boxes except Fri and Sat.

Since they're mutually exclusive (they can't both apply to the same day of the week since they have different days checked), the order in the list with respect to each other won't matter. Make sure you don't have a third basic daily rate still in the list -- it shouldn't be needed since these two cover all days of the week, and it could cause confusion.

Naturally if you also have discount rates, this will have to be repeated for each discounted daily rate.

Special Season or Holiday Rates

Creating special rates for holidays, peak seasons, etc. is similar to defining weekend/weekday rates. You'll need to duplicate each rate that will be different for the special dates, and enter the appropriate dates for which each one applies to.

This is usually done with the Season Dates Applicable field and the Special Dates Not Applic. field. While the Special Dates Applicable field can be used in some cases, you should ignore this one for now.

As a simple case, lets say that you have a special rate for July 3rd and 4th:

1. Duplicate the Basic daily rate (using Copy Selected Rate(s)).
2. Edit the new one, and change its descriptions as appropriate to indicate "July 4th rate", and of course change the Each amount.
3. In the Season Dates Applicable field, enter "7/3 to 7/4". Note that the year isn't needed since it's the same days every year. (If you have special cases like long weekends where you need to include an extra day, then you would have to include the year for those cases.)
4. Click Save.
5. Move that rate above the normal rate (Basic daily rate), so it will apply first if the reservation is on those dates. Note that it will only apply to those two days, and the regular rate will be used for the remainder of the days if the reservation is longer.

That's basically it. You can repeat as needed for other dates -- or if all holidays are the same rate, just include all of the holiday dates in the Season Dates Applicable field, separated by commas. For instance: "7/3 to 7/4, 5/28/05 to 5/30/05, 12/24" to include Memorial weekend in 2005 only, and Christmas Eve every year.

Naturally for any year-specific dates, you'll need to remember to adjust the dates every year. Be sure to leave in the old dates for awhile just in case you still have active reservations covering those dates, to prevent it from recalculating them incorrectly.

We mentioned the Special Dates Not Applic field but we didn't use it yet. Technically the right way to do it would be to also enter those same dates into the Special Dates Not Applic field in the Basic daily rate, to keep the normal rate from applying on the holidays. However if you make sure the holiday rate is above the normal rate so it will always be applied first, then you could skip this step. This reduces the maintenance needed each year, and also speeds things up a tiny bit.

Creating seasonal rates works basically the same way, simply with a larger date range. This often applies to monthly and weekly rates as well, so you would have to make seasonal copies of those rates also.

One thing to watch out for when entering seasonal dates is the end-of-year wraparound. If you don't include the year in the date range, it won't understand that "10/1 to 3/31" is supposed to wrap around the end of the year (and in fact it will think you entered it wrong, automatically changing it to "3/31 to 10/1"). So if a season wraps around the end of the year, enter it as two parts like "10/1 to 12/31, 1/1 to 3/31".

Special Reservation Types

So far the examples assume that all of your reservations are just general reservations ("Normal"), or variations on those that don't really affect the rate you charge ("Monthly" or "Group"). The Resv Types selection in the example rates has always been left with these defaults. You could change the monthly and pro-rated rates to only apply to "Monthly" reservation types if you prefer, to help keep things separate. Of course you would need to remember to set the reservation type appropriately for the reservations themselves.

You might also have special types of reservations like Seasonal that need separate rates (see below), or special cases that have no other easy way to qualify the rate it should use like a "Grandfathered" rate for certain people, or a special rate for "Online" reservations. It's often best to create special Reservation Types for these (see the Pick Lists), which not only lets you specify appropriate rates but also allows more detailed reporting.

Once you've created the special Reservation Types needed, you can define rates that apply to only those reservation types. This is simply a matter of selecting the appropriate Resv Types in the rate definition.

Be sure to check all of your rates to make sure there's no missing Resv Types that should be selected, or accidental overlap (rates applying to reservation types that it shouldn't) -- and remember that if the Resv Types selection is blank, the rate will apply to ALL reservation types.

Seasonal Stays

If you have a one-time fee for the entire season, regardless of how long they actually stay, then you may have to handle this differently because most Rental Rates are based on the length of stay. The best way to handle these is to first create a "Seasonal" Reservation Type through the Pick Lists as described above, and of course you'll need to select that Resv Type for any reservations that fall into this category.

Once you have the Seasonal reservation type added, you can set up a rental rate for seasonals (or more than one rate if there are other circumstances creating different seasonal fees). You need to select "Seasonal" in the Resv Types as mentioned above, but most importantly you also need to **uncheck** the Multiply by # periods option. This will cause it to charge the rate one time for the entire reservation, regardless of its length.

Rates for Fixed Fees

If you have a fixed fee that should reservations regardless of the length of stay, then you can do it as an add-on rate. This can be used for things like a reservation fee, a key deposit, or other one-time charge. It doesn't necessarily have to apply to everyone (you can qualify a key deposit to just cabins, for instance), just modify the steps below if needed to make it apply to the appropriate cases.

To set up a \$5.00 fixed fee that applies to all stays:

1. Click Add rate definition.
2. Select "Add-On" in the Rate Type field.
3. Enter "Fixed reservation fee" (or whatever it is) in the Description field.
4. Click the Charge button.
5. Select (click on) "Misc Extras" from the drop-down category list (or whatever category you might have added for this).
6. Press the **Tab** key to change to the Description field, and change it if you want (e.g. "Service charge").

7. Press the **Tab** key twice to get to the Each field (no Qty is necessary).
8. Enter the amount, not including taxes, for instance "5".
9. Press the **Tab** key to accept the amount.
10. Check the boxes for one or more taxes under Auto-add tax, if they apply.
11. Remove the checkboxes for Multiply by # periods, Multiply by # sites, and Ask for other quantity. Of course it this should apply multiple times for multiple sites, leave that box checked.
12. Select any Resv Types, Site Types, etc. that this charge should apply to. If it applies to everything, make sure these selections are cleared out.
13. Click the Save button.

That's it -- this rate will be added to all reservations matching the selected Applies-only-to criteria.

Merchandise Rates

If you have the Point of Sale option, you probably won't want to enter merchandise here. Otherwise, you can set up any number of rates that are actually merchandise items. This saves time when entering sales of fixed-cost items like RV supplies and dump services, or fixed-rate things like propane.

Once you have Merchandise rates set up, all rates with this type will be shown in Select Rates when you choose the "Merchandise" rate type at the top of that dialog. In addition, when you open Unbound Transactions, for instance by clicking the cash register icon in the toolbar, it will show all merchandise rates by default. This makes it easy to pick the selected rate and enter a quantity.

Setting up a merchandise rate is similar to setting up a fixed fee rate. To add Propane as a merchandise item at \$1.299 per gallon:

1. Click Add rate definition.
2. Select "Merchandise" in the Rate Type field.
3. Enter "Propane" in the Description field.
4. Click the Charge button.
5. Select (click on) "Propane" from the drop-down category list (or whatever category you might have added for this).
6. Press the **Tab** key to change to the Description field, and change it if you want (e.g. "Propane per gallon").
7. Press the **Tab** key twice to get to the Each field (no Qty is necessary).
8. Enter the amount per unit, not including taxes, for instance "1.299". Notice that you can include the fractional cents as added decimal places. It will show up to 4 places in the dialog, but the number will actually be stored and used for calculations exactly as you enter it.
9. Press the **Tab** key to accept the amount.
10. Check the boxes for one or more taxes under Auto-add tax, if they apply.
11. Click the Save button.

This is a simple example but should cover most merchandise issues.

Electric Meter Rates (also Water and Gas Meters)

Rates for meters are handled in a special way by Campground Master. They are used automatically when entering batch meter readings, and if you select a meter rate from Select Rates, it knows to ask for a reading. There are also some special parameters for meter readings so that you can handle things like tiered electricity rates or exclude a certain minimum amount that's included in their rent.

One key thing to know about meter rates is that when it's applying the rates automatically, it can apply one or two rates. One must be a variable rate, which is multiplied by the number of units used. The other one, if present, must be a fixed rate that's not multiplied (for instance a base service charge). If more than these two rates are found that apply to a given reservation, or if no variable rate is found that applies, it will show an error message.

As with rental and add-on rates, you can use any of the "applies-only-to" qualifying fields to create separate rates for different seasons, different reservation or site types, and so forth. You would create multiple sets of rates to handle each situation as needed, just like for rental rates.

This first example is the simplest case -- a single per-kWh rate for electric use, with no special filtering:

1. Click [Add rate definition](#).
2. Select "Electric Meter" in the [Rate Type](#) field.
3. Enter "Electric meter" in the [Description](#) field.
4. Click the [Charge](#) button.
5. Select (click on) "Electricity" from the drop-down category list (or whatever category you might have added for this).
6. Press the **Tab** key to change to the [Description](#) field, and change it if you want (e.g. "Metered electric"). Keep in mind that the current and previous readings will automatically be added to this description on their receipt, for instance "Metered electric (2500-2200)".
7. Press the **Tab** key twice to get to the [Each](#) field (no Qty is necessary).
8. Enter the amount per unit, not including taxes, for instance ".0623". Notice that you can include the fractional cents as added decimal places. It will show up to 4 places in the dialog, but the number will actually be stored and used for calculations exactly as you enter it.
9. Press the **Tab** key to accept the amount.
10. Check the boxes for one or more taxes under [Auto-add tax](#), if they apply.
11. Notice that the box [Ask for meter reading](#) will be checked automatically, and some other entry fields will appear. In this simple case, leave these as they are. (As a simple variation, you could enter "100" in the [Meter allowance](#) field if the customer gets the first 100 units for free and should be charged for the remainder of his usage, if any.)
12. Click the [Save](#) button.

Now if you go into a reservation's transactions, click [Select Rates](#), and select "Electric Meter" for the rate type, this rate will appear. If you click this rate and [Add](#), a window will appear showing the previous meter reading

and asking for the new reading. Simply enter the new reading and it will do the rest, including updating the last reading the in the Site Details.

Electric Meter - Base Charges

Sometimes a base service charge must be added every time the meter is read. This would be in addition to the per-unit charge, so you need to add a separate rate for it. So after adding the meter rate above, add another rate, let's say for a \$4.50 service charge:

1. Click Add rate definition.
2. Select "Electric Meter" in the Rate Type field.
3. Enter "Electric meter service charge" in the Description field.
4. Click the Charge button.
5. Select (click on) "Electricity" from the drop-down category list (or whatever category you might have added for this).
6. Press the **Tab** key to change to the Description field, and change it if you want (e.g. "Meter reading charge").
7. Press the **Tab** key twice to get to the Each field (no Qty is necessary).
8. Enter the amount of the charge, not including taxes, for instance "4.5".
9. Press the **Tab** key to accept the amount.
10. Check the boxes for one or more taxes under Auto-add tax, if they apply.
11. Remove the check in the Ask for meter reading box. This must be removed to indicate that it's a base rate, not a per-unit rate. If you don't do this, you'll get an error because multiple per-unit rates exist. Two other fields will still be shown below this because it's a meter rate, but leave those blank in this case.
12. Click the Save button.

Now when you meter charges, this rate will be added in addition to the per-unit charges. This will happen each time you enter a meter reading, no matter what the actual usage is or how often you do it.

As an additional note, remember that you're not limited to one transaction in a rate definition. For instance if you need to indicate more than one base charge like a service fee and separate meter reading fee, you can't create two separate base rates so just add the two Charge transactions into the one base rate.

Electric Meter - Tiered Rates

This is where it can get a little complicated, primarily in figuring out the amounts to enter for the rate charges. Remember that only one per-unit and one base rate can apply for any set of conditions -- this is solved by using the extra fields for Applies if >= ... units and Applies if <= ... units, which were ignored in the simple examples above.

The general process is to create a pair of rates for each range of units that define a different electricity rate. (If there is no base charge then the lowest range will only need the per-unit rate, but that's the only exception.) So we need one per-unit rate and one base rate for each range, and set the applies-if parameters accordingly for each pair of rates so that only one pair applies for any given meter reading.

As an example, let's say the rate is \$.06 for the first 200 units, \$.07 for 201 to 400 units, and \$.08 for any usage above 400. In addition, there's a service charge of \$10.00 per month (presumably the same as per reading). The per-unit portion of the rates in each range is simple enough, but you need to figure out how much the fixed, or base, part should be for each range.

- For 200 and under, the base is just the \$10.00 service charge.
- For 201 to 400, we need to add the total amount for the first 200 units of usage (because the per-unit rate will only calculate the \$.07 per unit above 200 units). So $\$.06 \times 200 = \12 , plus the \$10 service charge = \$22.
- Likewise for 401 and above, we need the total amount for the first 400 units. This would be the \$22 above (which includes the first 200 units), plus $\$.07 \times 200 = \14 for the next 200 units (201 to 400), for a base charge of \$36.

Now we're ready to create the rate definitions. Rather than go through each step for every rate, we'll just show a table below with the appropriate entries for each rate. Hopefully by now you know the basic mechanics of adding rates.

Rate 1: **Base rate, up to 200 units**

Each amount: **\$10.00** (service charge)
Ask for meter reading checkbox: **NOT checked**
Meter allowance field: (blank)
Applies if >= field: (blank)
Applies if <= field: **200**

Rate 2: **Per-unit rate, up to 200 units**

Each amount: **\$.06**
Ask for meter reading checkbox: **CHECKED**
Meter allowance field: (blank)
Applies if >= field: (blank)
Applies if <= field: **200**

Rate 3: **Base rate, 201 to 400 units**

Each amount: **\$22.00** (service charge + 200 units)
Ask for meter reading checkbox: **NOT checked**
Meter allowance field: (blank, doesn't matter)
Applies if >= field: **201**
Applies if <= field: **400**

Rate 4: **Per-unit rate, 201 to 400 units**

Each amount: **\$.07**
Ask for meter reading checkbox: **CHECKED**
Meter allowance field: **200**
Applies if >= field: **201**
Applies if <= field: **400**

Rate 5: **Base rate, 401 units and up**

Each amount: **\$36.00** (service charge + 400 units)
Ask for meter reading checkbox: **NOT checked**
Meter allowance field: (blank, doesn't matter)
Applies if >= field: **401**
Applies if <= field: (blank, no upper limit)

Rate 6: Per-unit rate, 401 units and up

Each amount: **\$.08**

Ask for meter reading checkbox: **CHECKED**

Meter allowance field: **400**

Applies if >= field: **401**

Applies if <= field: (blank, no upper limit)

Notice that the Applies-if fields define the 3 pairs of rates. Make sure they are mutually exclusive to separate each pair -- for instance don't put 400 in rates 5 and 6, or else two sets of rates would apply to exactly 400 units.

Deposits Setup

Overview

Deposit definitions are used to set up pre-defined amounts or calculation methods for Advance Deposit payments toward Reservations. (Don't confuse this with Security deposits, which are completely different.) These are similar in many ways to setting up Rates -- you can specify any number of definitions according to your different types of sites, reservations, seasons, reservation length, and so forth. However they can also make use of Auto-Rates (if you're using them), for instance if you require a 50% deposit based on the total charges then only one Deposit definition has to be set up for that, rather than a separate one for each different Rate definition you have.

Deposits are never added completely automatically -- after all, it has to know you're taking a payment for it. These definitions are simply used to fill in the "Amount of Deposit" automatically, once you get to the Enter Deposit screen through Reservation Transactions (or when Guaranteeing a reservation and you click Enter a Deposit Transaction now). Depending on the options in Program Options / Reservations, it can either populate the "Amount of Deposit" field as soon as you open that dialog, or you can add a button to Auto-Set the deposit amount when desired. Of course you still need to select the payment method, etc as with any other payment entry.

Depending on the Access Levels configuration and the level of the operator logged in, it may or may not allow changing the amount once it has been automatically set.

Deposits Setup Dialog

Start setting up deposit definitions by opening the Deposits Setup dialog (Maintenance / Park Setup / Deposits). This will list any already defined (if there are any), with their Description, Deposit Type, and whether it's enabled. From here you can add or edit deposits, delete obsolete deposits, and move deposits in the list.

You can also Print or Export the shown list at any time.

Adding or Editing Deposits

Note that the information shown for the Deposits in the list are coming from the Deposit Definitions -- they cannot be changed directly in the list. You need to Edit the definition to change it.

The basic procedure for defining a Deposit is to click Add definition, and then enter the details of the Deposits Definition including the applicable Deposit Calculation Type and parameters, along with the applicable sites, dates, etc that determine its function. Insert is the same as Add, except that the deposit will be inserted in the list at the current selection point, rather than added to the end of the list. You can edit any of the existing deposits by clicking on the deposit in the list and selecting Edit deposit definition, or you can double-click on the deposit in the list.

Warning -- Once a deposit is edited or deleted, there is no way to Cancel the operation -- the changes are permanent once you leave the Edit Deposit dialog and come back to the Set Up Deposits dialog.

You can Move, Delete, or Copy one or more deposits by selecting the deposits in the list (Ctrl-click or Shift-click will select multiple deposits), and then click the appropriate button. Copying deposits is very handy if you have groups of deposits that are similar but have slight variations, such as sites or season dates.

IMPORTANT -- Using the Deposit Definitions

The Deposits Setup is just the definitions -- they won't be used for anything unless you also set the options in Program Options / Reservations, so it knows what to use them for. It can either be set to populate the "Amount of Deposit" field as soon as you open that dialog, or you can add a button to Auto-Set the deposit amount when desired. **Don't forget this step!**

Deposit Order

Deposits are always checked top-down, from the first in the list to the last. As with Rates, the order can be important. When looking for an applicable deposit, it will use only the **first one** it finds that **applies** to the reservation. It will not combine multiple deposit amounts. So most of the same rules for Rates proper order apply to Deposits as well.

Add to or Remove date(s) from Deposits

These functions allow you to select any number of deposits, enter one or more dates or date ranges, and will add or remove those dates from the applicable dates for the deposits selected. It does so by adjusting the "Special Dates Applicable" or "Special Dates Not Applic." fields of the Deposit definition. It won't modify the "Season Dates" setting.

Importing and Exporting Deposits

These functions allow copying a deposits setup from one database to another (or between computers). This is used if you have your software provider do the setup on another system and then need to import that setup to the working database on your computer. The Import function will **only** work with files exported using the Export Deposits function here. It cannot import deposits from a user-created file.

The Export function creates a text (CSV) file in a special format that the Import function can read. This can include one or more definitions (select the entry or entries to export before clicking the Export button). To complete the export, select the location (Save in) and the file name for the exported file with the "Export" file dialog is shown.

The Import function is simply the reverse of Export -- select the CSV file containing the exported deposits, and Open it to import the deposits into your database.

Deposit Types

There are several different pre-defined Deposit Calculation Types, covering most situations needed. In addition there is one that will use a custom Expression calculation which should cover any possible situation. You can have as many different deposits of each type as you like. While these types cannot be changed, the "Applies only to" conditions of the Deposit Definition allow a lot of flexibility, including a fully programmable "Condition expression" -- essentially allowing limitless flexibility in the types of deposits you can create.

Remember that the Type is only one part of the definition -- in order for the deposit to apply to a reservation, the reservation must also meet all of the conditions specified in the "Applies only to..." section of the definition.

No deposit required -- If this definition applied, it will simply show a prompt that no deposit is required for the reservation. While this may seem unnecessary, it's more user-friendly to show that message than simply using a \$0 amount with no explanation, or an error that no applicable definition was found.

Must be manually entered -- Use this deposit type if there will always be special circumstances for this type of reservation, and you want to prompt the user to enter a manual deposit. Again, it's not strictly necessary, but more user-friendly than just showing \$0 or getting a "not found" error.

Fixed amount -- This can be used for a single fixed amount, but also can also be multiplied by the number of periods (days, weeks, etc) and also by the number of sites.

Percentage -- Use this to make the deposit a percentage of the total charges. It can either use whatever charges are already on the reservation, or the Auto-Rates charges (which may or may not already be added to the reservation. You can also include or exclude taxes.

First (# of) days/weeks/etc -- Use this to calculate a deposit as a fixed initial period, for instance a 1-night or 1-month deposit, or the first 4 days, or whatever you like. Of course it will be limited to the length of the reservation. You also need to enter the "First ___ (# of) _____" parameters, and select an amount to use. You can also include or exclude taxes.

Expression Calculation -- If no other type will work, you can use this to enter an Expression to calculate the deposit amount yourself. This is an advanced option, and most likely would need to be created by the software provider.

Other options

Depending on the Deposit Calculation Type selected above, some other options may be available.

Deposit amount -- Enter the amount of the deposit (e.g. for the Fixed amount type). This should only be the number, e.g. "100". Do **not** enter a dollar sign.

Percentage -- Enter the percentage (for the Percentage type). This should be the actual percent -- e.g. for 50%, enter only the number "50". Do **not** enter the percent sign.

Multiply by # periods -- Select this if you want to multiply the amount (e.g. a fixed amount) by the number (or multiple) of days, weeks, months, years or "periods" (e.g. hours).

Deposit is per ... (# of) -- Fill this in when multiplying by # periods. So for instance you can say the amount you've entered is per 1 day, per 3 days, per 1 week, etc.

First ... (# of) -- Fill this in when using the "First (# of)..." type. So for instance you can have it calculate for the first day, week, 2 days, month, etc.

Applies for a maximum of ... periods -- Along with the "Multiply by" / "Deposit is per", you can limit how many times the amount is applied. For instance it could be a per-day deposit but with a maximum of 4 days

Multiply by # sites -- select this to add the amount for each site. This will only count sites linked as Synchronized or Sub-members, since those will be combined billing.

Include taxes -- When using a Percentage or "First (# of)" type, you can either include the taxes or exclude them.

Amount to use (for Percentage or First # periods):

Use the charges already on the reservation -- Select this to calculate based on the charges already on the reservation. Of course this assumes you've already added charges (or auto-rates has already added the charges when the reservation was created). If using the "First (# of)" type, the result will be a pro-rated amount that assumes the charges are for the full stay.

Use the entire auto-calculated amount -- Assuming you have Auto-Rates fully functional, you can use this to calculate the deposit based on the total auto-calculated charges, for the entire reservation length. Be aware that this includes Monthly reservations -- e.g. if it's a 6-month reservation, this results in all 6 months' of charges (which you can then either use a percentage of or use the first month of, etc depending on the Deposit Type selected).

Auto-calculate as a reservation of that length -- This also requires Auto-Rates to be fully functional, but instead of pro-rating the calculated amount, it will calculate assuming it's a reservation of the "First (# of)" length. For instance if it's a 1-week reservation that normally gets a weekly discounted rate, but the deposit is for the First 1 night, it will calculate the deposit as if it's a 1-night reservation without the discounted rate.

Edit Deposit Dialog

When you select New, Insert, or Edit from Deposits Setup, the Edit Deposit Definition dialog will appear. This is where you define all of the details of the deposit.

Make sure that the desired Deposit Calculation Type is selected (this can be changed any time), and enter a Description.

Deposit Type

There are a fixed set of Deposit Types to choose from. The different types were covered in the previous section above.

Depending on the Deposit Calculation Type selected, other additional parameters may appear that must be filled in. This is typically the amount or percentage of the deposit, for instance, and whether to multiply it by the number of days/weeks/months or number of sites.

"Applies only to..." Filtering

This is the most important part of the setup.

The rest of the dialog entries are used to "qualify" a deposit. This determines whether the deposit definition applies to any given reservation, so it's important to get this set up properly.

Resv Types

You can select one or more Reservation Types for which the deposit applies. Click the [Resv Types](#) button to open a list of reservation types, and select any that are applicable. For instance, you may have different deposits for Monthly reservations than your Normal reservations. As with any of the lists here, an empty list (selecting nothing) means that it will apply to **all** types -- in other words, "not filtered".

Site Types, Site Classes, or Sites

If this deposit only applies to certain Site Types, click the [Site Types](#) button and select the applicable types from the list that appears. If no site type is selected, the deposit will apply to reservations of any site type (assuming other filters don't exclude it). If you select one or more site types here, then that deposit will only apply when a reservation is for one of those site types.

Likewise, you can have a deposit apply to specific Site Classes, using the [Site Classes](#) button, or even one or more specific sites using the [Sites](#) button. However you don't need to set all three (types, classes, and sites) -- usually only one of these selections is enough to sufficiently qualify the deposit. For instance if you select "Normal RV" for the Site Type, there's no need to select "RV's" for the site class because it's redundant -- all "Normal RV" sites will have an "RV's" class anyway, so there's no need to make the deposit check this too.

Only applies if NO site is assigned

This is a special-case option. If this deposit should **only** apply if there is no site assigned, you must check this option (since there is no way to specify "no site" with the other selection lists).

Discounts

If you offer discounts, such as Senior discounts or Good Sam membership discounts, then you can set up special deposit definitions for them. Filter each deposit definition for the appropriate discount(s) by either selecting one or more discounts from the [Discounts](#) list, or by checking the [Only applies if no discount used](#) check box if it should only apply when no discount is used. As with Site Type, this will determine whether the deposit will appear in the deposit selection list for a given reservation.

Applies if ... days

You can set up the deposit to apply only if the reservation is longer or shorter than a given number of days, by setting the [Applies if >= days](#) and [Applies if <= days](#) fields.

Applies if reservation field...

The [Applies if reservation field...](#) selection permits a great deal of control over when a deposit applies. This specifies that the deposit applies to a particular "preference" setting in the reservation or one of the "# of" or value fields such as number of adults, extra vehicles, or rig length.

To use this option, select a reservation field from the list. Some numeric fields are also available in additive combinations also, primarily to allow "# Adults + # Children" to be selected if it's based on the total number of people.

If the field is an attribute/preference field, such as "50A", then you can specify whether the deposit will apply only if that preference is "true" (set to "Must Have") for the reservation, or whether it's "False" (not set or set to "Must Not Have" are both considered false in this case). Therefore you can set up two separate deposits that are mutually exclusive, one for the True case and one for the False case of the preference field.

If the field is a numeric value, additional settings will appear that need to be entered. You will first enter a value for "is >=" ("is greater than or equal to") to indicate when the deposit applies.

Adding new fields -- If you need add your own fields for use in deposits like this, then note that they must be tagged as "Attrib" fields in order to be selectable from this list. See the special note about Attribute Fields under the **Adding New Fields** section of the Data Field Definitions topic.

Advanced Condition Expression...

If the deposit can't be properly qualified using the other Applies-if conditions, date selections, etc, then you can use Expressions to create a condition as complex as needed. Note that this involves the Advanced Customizations functionality and is only recommended for very technical users, so refer to that section for more detailed information.

If a Condition Expression is entered here, it must be satisfied (result in True) in addition to all other conditions in the deposit definition in order for the deposit to be used. Thus you can use the other Applies-if conditions to handle the simple stuff, and use the expression to only do the filtering that can't be otherwise handled by the deposit definition.

The expression will have **ThisResv()** context which will be the specific reservation being checked (e.g. if there are 5 synchronize reservations being added, this expression will be executed for each reservation individually). In addition, **ThisFromDate()** and **ThisToDate()** will indicate the date range of the reservation as well as **ThisFromPeriod()** and **ThisToPeriod()** if it's an hourly/scheduled reservation). **IMPORTANT** -- The reservation in **ThisResv()** will usually be a temporary copy of the reservation, not the actual record in the database. While this won't matter in most cases, be aware that it could appear as a duplicate to one in the database, especially if the deposit is being checked for changes to an existing reservation.

Deposit Dates

You can define the dates for which any deposit is applicable. Defining dates for a Deposit definition is just like defining dates that a Site is available or Rates are applicable (see Edit Site Details or Edit Rate Definition).

Notes

The Notes field is just for your own notes, perhaps an explanation of why a deposit is set up the way it is. The Notes are never seen by the customer or by an operator selecting a deposit. The notes can be any length.

Operator Setup

The Operator Setup function ([Maintenance / Park Setup / Operators](#)) can only be viewed by an operator with Administrator access. This is where an administrator will set up all operator logins for the software. Note that since the operator table is stored with the database, operators will be backed up and restored with it. If you start a new database, you will need to set up new operators for it.

PCI Compliance note: Refer to the [PCI/PA-DSS Compliance Guide](#) (see the *Introduction* chapter) for important details about proper security procedures if credit card information is stored in Campground Master.

The Operator Setup dialog lists all current operators, with buttons to Add, Edit, Copy, or Delete operators. Double-clicking on an operator in the list will also edit it. This will open the Edit Operator dialog with the detail entry fields.

To add additional operators, simply click [Add Operator](#). A new, blank record will be shown in the Edit Operator dialog and you can enter the details.

There must always be at least one operator defined with Administrator access. (Otherwise you could never access critical functions, or add an operator that could.) Therefore, if a database is loaded that does not have an Administrator operator, you will see a warning and it will automatically set one of the operators to Administrator (it will tell you which one). A new Administrator operator will be added if no operators exist.

By default, the database will start with one operator, with Administrator access. The login parameters for this operator will be:

Login: **Administrator**

Password: **Password**

Obviously this is not a secure situation -- besides being too obvious, anyone with access to this manual (or the software's Help function) can find out how to get in to the system. Therefore you should immediately change this operator information (it should prompt you to change the password the first time you log in).

You should assign the Administrator access level very sparingly. While it would be convenient to make yourself (or everyone) an administrator, it opens up the possibilities of making disastrous changes by mistake. We recommend having one or two administrator logins assigned, and make them *in addition* to the logins you use on a daily basis. The campground managers should have Manager access for daily use, and any other users should have Reservations or Clerk access as appropriate.

Always keep your Administrator login(s) recorded and in a secure place where you can remember where to find it. It might be months before you need to use it, so relying on your memory for the password is not a good idea. If you forget the administrator login, it is possible for Cottonwood Software to retrieve it, given a copy of the database file. However it is a hassle (and possible support expense) that you'll want to avoid.

Automatic Login

If you are the only person that will ever use the program, you may want to set it up to automatically log in with your operator name when the program starts. You will have to decide whether it's worth the risk (e.g. if anyone else has access to the computer, they would have complete access to the database), but this option is provided for convenience.

PCI compliance warning -- using an automatic login bypasses the 90-day password change requirement for PCI compliance, so it should not be used if credit card information is stored in the system.

To set up automatic login, you will need to add two parameters to the "command line" of a shortcut icon to the program. To do this, right-click on the Campground Master icon on your desktop (or wherever you start the program from), then click on the Shortcut tab. The Target edit box should contain the full path of the CampgroundMaster.exe file, which is the command line. Go to the end of the line and add the following text, replacing **[login]** and **[password]** with your appropriate login and password:

```
/Operator=[login] /Password=[password]
```

Note the capitalization of Operator and Password, the direction of the slashes, and **make sure there is a space before each slash**, including the first one. For example, to log in with the default administrator and password, add this to the command line:

```
/Operator=Administrator /Password=Password
```

Also note that the program file and path should have quotes around them (which may already be there) -- so a typical complete target line would be:

```
"C:\Program files (x86)\Campground  
Master\CampgroundMaster.exe" /Operator=Administrator /Password=Password
```

Deleting Operators

If necessary, you may delete operators from the system. It won't cause a problem in the database since the actual operator code, rather than a link to the record, is stored in reservations and transactions. However, you probably won't want to delete operators once they are used because you can show Transaction reports based on operator, and operators can only be selected for reports if they are still in the database. If you need to "lock out" an operator, you can either change the operator's password or change the access level to Guest, which would prevent the operator from making any changes to the data (depending on the Access Levels settings).

Operator Login

The Operator Login is the operator's ID used when logging in. It's never seen anywhere else in the system, so it can be whatever the operator prefers. It can be the same as the Operator Code, or it can be different. Login names are not case sensitive, so for instance "Walter" is the same as "waltzer" or "WALTER". This may be changed at any time without any affect on the program or database.

You cannot add more than one Operator using the same Login name -- each operator name must be different. (Older versions allowed duplicate Login names, but this is no longer allowed).

Password

The Password is used by the operator when logging in. Like the Login name, it can be anything the operator wants, and is not case sensitive. It does not have to be unique -- any number of operators can have the same password. Of course this should not be done on purpose -- it's best for each operator to have a unique password, but if two people choose the same password it will not be a problem.

Force password change every 90 days -- This option forces the operator to change the password if it has been 90 days or more since the last login. *This is required to be enabled for PCI compliance.*

Complex password required -- This option enhances security by forcing numbers in passwords and requiring at least 8 characters. *This is required to be enabled for PCI compliance.*

Access Level

This defines the operator's key to the system. There are five different access levels, with increasing access to program functions. They are checked for many different functions, most of which are covered separately with the function descriptions elsewhere in the manual. The access level required for many program functions can also be changed if needed -- see Access Levels Setup. Here are then general descriptions of the levels:

(Not logged in) -- If no operator is logged in, nearly all program functions are disabled. The first Tab View is shown (usually the Rack), but is not operable.

Guest -- minimal access, can only view the Rack. Cannot make any data changes or save the database (thus cannot make a backup or save a copy somewhere else).

Clerk -- has access to transactions and functions suitable for a point-of-sale or to accept payment for reservations, but cannot make or change reservations, perform any maintenance functions, or make program option changes.

Reservations -- Can access any reservation functions and reports, and can backup the database, but cannot restore the database perform other maintenance functions, and cannot change old transactions.

Manager -- Can access all report and option functions, plus restore the database, edit or delete old transactions, and edit Site details, but cannot access other maintenance functions.

Administrator -- can do anything.

Operator Code

The Operator Code is the text that will be shown anywhere in the system when referring to the operator (e.g. in reservation and transaction dialogs, report filtering, and the program caption when the operator is logged in). This should be a fairly short word, typically the operator's first or last name. Make **sure** it is unique (and easy to recognize), since it's used to identify this operator. No two operators should have the same operator code. This code should never be changed once it is in use, since that would have the same problems as deleting the operator (see above).

Auto-Logout

If a number of minutes is entered for "Auto-Logout after...", then the operator will automatically be logged out if the system is sitting on the main screen and is not used in the designated amount of time. Any action (moving the mouse, function dialog, etc.) will reset the timeout. If this is left blank, operators will never be logged out automatically. ***This is required to be set to 15 minutes or less for PCI compliance.***

Notes

The Notes field is only seen on Operator Setup dialog, so it can be used for any notes the administrator wants to make about an operator. Like other notes fields, it can be any length and format. Typical notes might be phone numbers or other contact information (in case a question arises), and information about temporary operators (like work campers) that might be of interest years from now by new campground managers (or auditors).

Access Levels Setup

The Access Levels setup dialog (Maintenance / Park Setup / Access Levels) can only be viewed by an operator with Administrator access. This is where an administrator will set up the minimum access level required for various program functions.

Each configurable program function will be listed along with its default access level and current (overridden) access level, if any. The current level for each function will be blank as long as it has not been overridden before, and will only change if you edit the function's level.

Note that the access level for many maintenance functions require Administrator access and cannot be changed, most reservation-editing functions are fixed at the Reservations level, and basic functions like unbound/customer transaction entry and customer editing is fixed at the Clerk level. The configurable functions are the ones that you may want to decide whether you want to make them available to Reservation, Manager, or Administrator levels depending on your situation.

Editing Access Levels

To change the minimum access level required to perform a function, click on a function to highlight it and click Edit access level (or you can simply double-click on the function name). A new dialog will appear to **Add/edit Access Level Override**. This shows the function name and default level -- just select the New Minimum Access Level from the drop-down list. There is also a special "**Nobody**" selection, which would make that function unavailable even to Administrators (effectively disabling the function), and also a "**(logged out)**" selection in case you want to make it available even if no operator is logged in.

Note that if you change the level back to its default, it will show that in both the Default and the Current level. That's OK, it just means that it has been overridden before but is currently back to the default.

Maps Setup

Overview

Campground Master supports a park map view so that you can see site status and manipulate reservations directly on the map. The only technical requirement for this is a digitized map file in a specific format. Starting with this map file, you can specify the location of each site (and size/shape), and Campground Master will do the rest. The "editing" capabilities for layout out the sites are very basic, but they do allow you to control the layout and the editing requires no knowledge of computer graphics or programming.

Maps Setup Dialog

(Accessed through Maintenance / Park Setup / Maps.)

In order to put a map in Campground Master and make the map "interactive" so it shows the status of each site, allows clicking on sites to make reservations, etc., you need to do 2 things:

1. Add a map entry, which opens a map image of your choosing.
2. Add Site "indicator" elements to the map so the program knows where each site is. These indicators show the color-coded status and allow clicking on each site for making reservations and other functions. See Adding and Editing Site Elements.

To start setting up a map (or to edit the map later), start from Maintenance / Park Setup / Maps. This will open the Set Up Maps dialog, which simply shows a list of current maps defined (if any), and buttons to add, edit, delete, and move maps around the list. Any number of maps can be defined, and this list corresponds with the list of maps available (from the drop-down list) on the Map tab view. The order in the list here determines the order in the drop-down list, and the first map in the list will be shown by default unless a different default is selected on the Map Options (from the tab view controls). The only information shown in this dialog is the map name (as it will appear in the list) and the filename of the map image.

The main reason that you might have multiple maps is that the visible area of each map is limited in the tab view (and it cannot be scrolled). Therefore if your park is too large to show in one view without making the sites unreasonably small, you would want to split your park into different sections and show each section on a separate map view. You might also have multiple maps for the same area if there is a significant change in the use for that area in different seasons or for special events.

Click Add map entry to define a new Map, which will open the Edit Map Dialog. This is where you will select a map file to use as the background and define the site locations.

Note: A map image cannot be created from scratch inside Campground Master -- you must have a bitmap (.bmp) file to start with, which Campground Master will use as a background for the site indicators you add here. You can use the Paint program that comes with Windows to create a basic map or convert an existing image to bitmap format (go to Start / Programs / Accessories to find the Paint program). If you want to do something fancier, you can use Corel Draw, Paint Shop Pro, PhotoShop, Visio, or any similar drawing

program. See the next section, Edit Map Dialog, for more details on the format required for Campground Master.

You can edit any map already listed by clicking on the map in the list and selecting Edit map entry (or you can double-click on the map in the list). You can also Move or Delete one or more maps by selecting the map(s) in the list (Ctrl-click or Shift-click will select multiple maps), and then click the appropriate button. Note that if you delete a map, all of its elements are also deleted automatically.

The Copy map entry function will make a copy of the selected map record (and show "copy" in the name) -- this will create a new entry that references the same map (bmp) file, but makes new copies of all map elements so it's effectively a separate map view. This is handy if you want to make a temporary copy for testing some changes to the indicators, for instance, without affecting the "live" map. You can also change the map image file, but of course if the sites aren't in the same positions then the indicators will need to be changed. If you just want to start a new map that will need all new indicators, it's better to use Add instead of Copy.

Warning -- All changes to maps are permanent -- there is no way to cancel the operation. (Moving maps in the list is also "permanent" since there is no Cancel button, but you can always move them back.) Making a backup is recommended before any significant changes are made to a map.

Importing and Exporting Maps

These functions allow copying a map setup from one database to another (or between computers). This is primarily used if you have your software provider do the setup on another system and then need to import that setup to the working database on your computer.

The Export function creates a text (CSV) file in a special format that the Import function can read. This can include one or more map entries (select the entry or entries to export before clicking the Export button). It will export the map entry with the name, file name, and all site indicator elements.

Note that the map image file (BMP file) is **not** exported or imported -- it will need to be copied separately if needed.

The Import function is simply the reverse of Export -- select the CSV file containing a map export, and Open it to import the map entries into your database. Again, the map image file itself is not imported, only the name of the map file -- so you may have to copy the map image manually into the proper folder (or use Browse to locate it, and it will be copied to the correct place automatically).

Edit Map Dialog

When you select Add Map Entry or Edit Map Entry from Set Up Maps, the Edit Map dialog will appear. This is where you select the map name and image file, and position all of the site status elements.

This dialog only has a two entry fields -- Map name and Image File. The dialog will automatically be sized to match the program main window, and rest of the dialog is used to show the map and edit the site indicators.

Map Name

If this is a new map, enter a name for the map (the way you want it to appear in the list of maps on the Map tab view). This should be limited to the size of the entry box to avoid truncation. If editing a map, you can change the name as needed. Each map should have a unique name for identification.

Image File

This is the file name of the map image. No path should be entered, only the file name. All map images must reside in the same folder as the database (and must be present on each computer if using the program on multiple computers or a network). A Browse function is available for convenience in selecting a file instead of typing in the name. If the map image is currently in a different folder than your database, you will be given the option to copy it into the correct location automatically.

Site Indicators (Map Elements)

Don't forget that the image you load is just used as a background -- you must still add the site indicator elements which will show the status of each site and allow you to interact with the map in the Map tab view. Adding the site indicators is as simple as right-clicking on each site in the map (you need to be in Edit Map dialog to do this, not on the Map tab view). This is described in detail further below.

Image File Format

The image file must be in a specific format for Campground Master to read it:

Windows Bitmap (.BMP) with RGB encoding, in either 16 or 256 colors

Note: The 16 above refers to colors, not "bits" -- a 16-bit format will not work. In terms of "bits", it must be 4-bit or 8-bit format.

If the image is not in this format, an error will be shown when attempting to load the image. Note that an RLE-encoded (run length encoded) bitmap cannot be used, it must be RGB encoded. If your image is not in this format, use an image editing program to change the format, such as the Windows "Paint" program. When saving the file, be sure to change the File Type to "256 color Windows BMP" (wording depends on the specific application, but look for "256" and "BMP" or "bitmap"). In some image programs, like Paint Shop Pro, you need to use the "Decrease # of colors" option to make it a 256-color image, and then save as a Windows BMP file.

Changing an image to the correct format

If you can't find a way to save it in the proper format using your image program, then save it as a JPEG. Then use the Windows "Paint" program (see Start / Programs / Accessories for the Paint program). Open the JPEG file, then use File / Save As, and before saving it change the File Type to "256 color Windows BMP".

Image Size

The image size is also important, since it must fit in the tab view window. It cannot be scrolled in Campground Master -- if you find it impossible to fit your entire map in this area, then you can create multiple maps with each one showing part of the overall map.

Note that the area of the map visible in the Edit Map dialog is the maximum that can be shown with the current program window size, but that assumes that the Toolbar and Status Bar settings will always be the same as they are currently. We recommend making sure that both the toolbar and status bar are on when editing the map (see the View menu), so it will show the minimum size available.

The chart below shows typical image sizes for various display resolutions. Note that if you're on a network, keep in mind the *smallest* display resolution of all of your workstations. These sizes assume that the toolbar and status bar are both on, and that the Windows Task bar is visible at the top or bottom of the screen. Also, the window settings can affect how much area is actually visible (font size, border widths, etc.). So before

going too far with map editing, be sure to check the Map tab view and make sure the map is sized appropriately (make sure you can see all of the map).

Screen Resolution	Map Image Maximum Size
640 x 480	630 x 290
800 x 600	790 x 410
1024 x 768	1014 x 578
1280 x 1024	1270 x 834

To find your Screen Resolution:

The screen resolution and maximum map size will be shown at the top of the Edit Map dialog. However, that's only useful when you're on the computer that you will ultimately be using for Campground Master. If you're setting up the map on a different computer, or if more than one computer will be used, you should check the resolution on each computer that will be used and base your map size on the lowest resolution of those.

To check the screen resolution on Windows XP and earlier: Right-click on the desktop and select Properties (or go to Start, Settings, Control Panel, Display), and click on the Settings tab.

To check the screen resolution on Windows Vista: From the Start button go to Control Panel, Appearance and Personalization, Personalization, Display Settings, Resolution.

Scanning maps or photos

If you already have a map in hard-copy format (or even an aerial photo), you can use a scanner and appropriate software to digitize that image for use in Campground Master. You will probably want to scan it at a higher resolution for clarity, then use a good image editing software package to clean up, trim and re-size the image as needed. Don't forget to save the image file in the correct format (see above).

Other image considerations

Try to avoid using an image with colors close to the site status colors (the bright yellow, green, red, etc.), to avoid confusion. The best map image would have a light (but not white) background, light colors for features like trees, buildings, etc., and black or dark colors for site borders. A white background is actually not recommended since the default "available" site status is white -- if the background is white, it's not as easy to notice available sites. However if a white background is all that's available, the status color for an available site could be changed to something else -- perhaps a very light blue color.

Whether the image already has site numbers on it, or whether the sites already have some shading or color indication of the type of site, may determine the kind of status indicators that are suitable -- conversely, you may decide to use an image with or without site numbers or shading based on the type of indicators you prefer to use. This is all very subjective, and Campground Master offers different indicator choices so that just about any type of map can be used. Most likely you will want to experiment with the different possibilities before setting up the entire map.

If you intend to use the "Fill" indicator type (nice for odd-shaped sites), there are a couple very important prerequisites -- the Fill indicator will flood-fill an area that is **exactly** the same color as the starting point of the fill indicator. This not only means that the boundaries of the site must be complete and in a different color than the interior (e.g. a complete rectangle) so the color doesn't "bleed" out to the rest of the map, but it also means that a **solid** color must be used for the interior. If you are scanning an image from a hard copy, this is rarely the case due to minor color variations, and photo editing software may need to be used to clean up the image.

Note: If you add an indicator and suddenly the whole map turns green, then it's bleeding out to the rest of the map. You need to find that indicator location to right-click it again and delete it, which could be tricky.

If your park is large, you will probably need to split the map up into separate map pages. The map page can be changed with the controls on the map display and with page up/down keys, but you can also put "hotspots" on the images to change maps with a mouse click -- this is especially handy for an overview map, where clicking on a section can switch to another map showing that section in detail (see below).

Adding and Editing Map Elements

Once you have the map image loaded, you need to add the "elements" that will appear on the map. An element is basically an object that indicates the status of a site, or a clickable hotspot to change maps. You can place any number of elements on a map, and more than one element can indicate the same site if necessary, either on the same map or separate maps.

All of the Element functions are accessed through the right-click menu. When you right-click anywhere on the map image, a right-click menu will appear with appropriate choices -- either to edit/delete an existing element or to add a new element. Note that the exact point you click on will be used for placing site elements, so careful clicking will avoid having to edit the element later. Also note that the point you click on means something different for each type of indicator (described later).

When you're done adding elements (or want to check the map in the real tab view at any time), click Close on the Edit Map and Set Up Maps dialogs. All changes are saved automatically.

Element Types

There are two basic types of elements -- Site Indicators and Hotspots.

Site indicators are placed on the map to show the status of each site. This can be on top of a site on the map image, next to it, or anywhere you like, and can be any size needed. There are three types to choose from -- Rectangles, Circles, or Fills (which automatically become the shape of the object you place it in. You could even start with a blank map and just arrange the site indicators to create the layout of your park (of course it's nicer to show roads and landmarks as points of reference, but that's entirely up to you.) Site indicators are interactive in the Map View. Besides changing color to indicate the status of the site, they will show the occupant or site name when the mouse is over them, and also have double-click and right-click menu functions very similar to the Rack.

Hotspots are invisible on the map, but perform a function when the user clicks on that area -- in this case, it will switch to a specified map. Of course these are only useful if you have more than one map image. A hotspot can be any size, but can only be a rectangle. Hotspots are used to make "buttons" on a map that will change map pages. The actual buttons need to be part of the map image and you define the area of the button with a Change-Map Hotspot, so you can make the buttons look like anything you want. You can also set up one page to be an overview of the whole park, and set up "hotspots" such that when a section of the overview is clicked on, it switches to the zoomed-in map for that section with the actual site status indicators (and you can add "Overview" buttons on the zoomed-in sections to make it easy to get back to the overview).

Adding Elements

To add an Element, you must right-click on an area of the map that doesn't already have an Element (they shouldn't overlap). Then select one of the "Add" options for a site indicator or other element.

An appropriate Add/Edit Element dialog will appear, where you can specify the details like which site the indicator should show, the size and position, and text if needed. (See the section below for details on this dialog.) Click Save, and you will immediately see the indicator appear on the map. While you're in this setup mode, the color of site indicators will be green, similar to the "site occupied" indicator, regardless of the current status of the site. (This color can be changed through the Maps Color Key.) Hotspot elements will simply be a black border (since they are normally invisible).

Double-click to add more of the same element

Once you have added one site indicator, you can use double-click as a shortcut to add more. Just double-click the left mouse button to add the same type of indicator as the previous one. The next site in the list will be selected automatically, and the size will be the same. So in many cases, all you have to do is click Save on the Add dialog and go on to the next one. The Save button is the default button on the Add dialog, so you could also just press the **Enter** key -- use two hands, one on the mouse and one on the Enter key, for quickly adding many sites. Just be sure to start with the "first" site and go in the order they appear in the site selection list (which is the same order as on the Rack).

Note that other than for this convenience of adding many in a row, there is no need to add site indicator elements in any particular order.

Editing Elements

To edit an existing element, for instance to adjust the position of an element just added, right-click on the element and select "Edit Element". You can also double-click on an element to edit it. The same Add/Edit dialog will appear and you can change the X and Y values to adjust the position. You can also change the size or the text. (Click near the "center" of the element for the best results -- if you click near the edge, it may not know that you're trying to select that element.) If you're adjusting the position, keep in mind that the X and Y values are in pixels (screen dots), and 0,0 is in the upper left corner (rather than the lower left as in traditional math class graphs). So for instance you need to increase the Y value to move an element down.

Note that there is no way to change the element type, so for instance if you want to change from a circle to a rectangle then you must delete the circle element and add a new rectangle one.

Deleting Elements

As with editing, just right-click on an existing element and select Delete element. A confirmation prompt will be shown, which is the only chance to change your mind -- once an element is deleted, it cannot be recovered and would have to be added again if you make a mistake. Note that if you want to completely delete a map, there is no need to delete its elements first -- just use Delete Map from the Maps Setup Dialog.

X, Y Positions

As mentioned earlier, the "position" of an element means different things for each element:

- **Site Indicator Rectangle** -- the position is the upper left corner of the element.
- **Site Indicator Circle** -- the position is the center of the circle.
- **Site Indicator Fill** -- the position is the "start" position of the flood-fill operation, and also the center of an imaginary rectangle for detecting mouse clicks (the rectangle size is determined by the Height and Width values).
- **Hotspot** -- the position is the upper left corner of the element.

Since there is no drag-and-drop support for map editing, you must use the Edit function to change an element's position manually.

Element Borders

Rectangle and circle site indicators will have a border that can be a different color than the interior of the indicator. The colors are configured through the Color Key. If you choose to show text in the indicator, the text will also use the same color as the border (therefore if you want text to show up, the border will also have to be visible).

Fill indicators have no border (since the shape can be irregular), but they can have text.

Hotspot elements have no border since they are normally invisible, but will have a black border when editing so you can properly set its size and position over the image.

Element Text

Any of the site indicator elements can have text added to the indicator by the program. The text can be specified for each element -- you can default the text to the site's abbreviation for convenience when adding elements, but keep in mind that once the element is added the text won't change automatically if the site abbreviation is changed. Whether you use text on the elements is up to you -- obviously if the sites are already numbered on the map (and the indicator doesn't cover that number up), there is no reason to add the number on the indicator. Also, the site indicators may be too small on the map for the text to fit, in which case the map graphic should include the site numbers.

If text is used, the text will be positioned in the center of the indicator. For rectangles and circles, the center is visually obvious. For fill elements, the center is determined by the position and size chosen for the element. In many cases this allows you to adjust the text position of a fill element for the best position within the area being filled. Also note that the text will be limited to the "size" of the element -- if the text is too large for the size, it will be cropped. For circle elements, the "size" assumes it's a square so the text can appear slightly outside the actual circle. For fill elements, the Height and Width of the element is used for the size of the text area.

Text Font

The font for the text defaults to "MS Sans Serif", which is the same font that's used throughout the program on the grids, dialogs, etc. This provides the most crisp results for readability. You can choose a different font type if you prefer, and/or change the size of the font or make it bold.

As long as you don't close Campground Master, the last font selected will be used for the next element added. This makes it easy to add a number of sites in a row with the same font (and orientation, below), especially if using the double-click shortcut to add the next site. Any time you want to reset it to the default font, just click the [Reset to default](#) button.

Note: If using Campground Master on multiple workstations, be careful about selecting an unusual font -- the other workstations may not have the same fonts installed. In this case, the text would be shown as some default font like Arial.

Text Angle

You can also change the orientation Angle of the text, for instance to fit the text in a vertically oriented site or a diagonal site. Note that the default "MS Sans Serif" font cannot be used for angled text, so you'll need to choose a different font like Arial (you can use the [Select Font](#) button or just type in the font name). An angle of 0 is the default horizontal orientation. The angle can range from 0 to 360 degrees, and increases counter-clockwise. So an angle of 90 is vertical reading up, 270 is vertical reading down, 45 is diagonal going up, 315 is diagonal going down, and so forth. Regardless of the angle chosen, the text will still be centered in the indicator as described before, and would also be cropped if it extends beyond the indicator's size.

Change-Map Hotspot Map Name

The target map name must be set for hotspot elements to change maps. Note that this must be the "Map name" you give a map, not its image file name. It must also match exactly, including case ("Map" is not the same as "map"). This also means that if you change the name of a map, any associated hotspots must also be changed.

Raw Data Tables

The raw data tables for the maps and map elements can be viewed and edited (see Maintenance / Raw Data Tables), but as always please use extreme care when doing this. The primary reason to use the raw data tables would be to make some adjustment to a large number of elements at once, such as slight adjustments to positions or sizes, or perhaps to change the text for all of them.

Add/Edit Site Indicator Dialog

This dialog is used when you Add or Edit a site indicator element from the Edit Map dialog (see that section for a description of the element settings). All of the details of an element can be entered or changed here, except for the element type and which map it appears on.

Default values when adding an element

The Site list is used to select which site this indicator will show status for. If you're adding a site, the "next" site will automatically be selected (the one after the previously added or edited element), making it easy to add multiple sites in a row.

The X and Y position coordinates will default to the position where you clicked the mouse button, but can be changed here if needed.

The Height and Width will default to the same values as the last element edited or added. (Height and Width will not be shown for Circle elements.)

The Diameter will only be shown for Circle elements, and will default to the same value as the last element edited or added.

The Text will be blank unless the Default to site abbreviation box was checked for the previous element, in which case it will default to the selected site's abbreviation (and will change if a different site is selected). Note however that once the element is added, the text won't automatically change if the site's actual abbreviation is changed.

The Font name will be the normal "MS Sand Serif" font, Size 12, not bold, and Angle 0.

Add/Edit Hotspot Dialog

This dialog is used when you Add or Edit a hotspot element from the Edit Map dialog. All of the details of a hotspot element can be entered or changed here, except for the element type and which map it appears on.

Default values when adding an element

The X and Y position coordinates will default to the position where you clicked the mouse button, but can be changed here if needed.

The Height and Width will default to the same values as the last element edited or added. These dictate the area of the map that will be sensitive to the mouse click for the hotspot action.

The Change to map named field will be blank to begin with, and must be set to the map name you want to change to when the hotspot is clicked. This must be an exact match, case-sensitive.

Schedules

(Accessed through Maintenance / Park Setup / Schedules.)

Schedules are used for intra-day reservations, for instance hourly rentals, tours, etc. There are several steps required to set up Campground Master to handle reservation "schedules", which are detailed below.

There are three rules you need to keep in mind when setting up schedules:

1. Never select the same Reservation Type for more than one Schedule. (But the same Schedule can use more than one Reservation Type.)
2. Make sure the "Base type" for any Reservation Types used for schedules is set to "Hourly".
3. Make sure all Sites of the same Site Type are in the same Schedule. (But the same Schedule can be used for more than one Site Type.)

Schedule Setup Procedure

First you need to enable some data fields (these are disabled by default to save database space, since most users don't need them).

Enable the Period fields for Reservations:

1. Go to Maintenance / Data Field Definitions / Reservation Fields.
2. Change each of the 5 period fields from Disabled to Enabled ("Resv_First_Period" through "Resv_Charged_Thru_Period").

Enable the Schedule field for Sites:

1. Go to Maintenance / Data Field Definitions / Site Fields.
2. Change the "Site_Schedule" field from Disabled to Enabled.

Add one or more Site Types for your scheduled sites.

1. Go to Maintenance / Pick Lists / Site Types.
2. Check "Allow editing of fields".
3. Click "New Record".
4. Enter appropriate site type info (e.g. Kayak, Canoe, Horseback Tour, etc.). The Selection Name field is the most important, as that will appear in the drop-down pick-lists.
5. Repeat for any other site types, Close when finished.

Note: You can use more than one site type for a particular kind of schedule (e.g. you could have different tour types all using the same tour schedule, or you might have canoes, kayaks, etc. all on an hourly schedule), but since you can't use the same site type for multiple schedules, you need to set up at least one site type for each schedule definition needed (see below). So for instance if you have canoe trips hourly but raft trips only twice per day, then they would need separate Schedules and thus separate Site Types.

Set up one or more Reservation Types to use for scheduled reservations:

1. Go to Maintenance / Pick Lists / Reservation Types.
2. Check "Allow editing of fields".
3. Click "New Record".
4. Enter the information for this reservation type. Example:

Selection Name:	Tours	
Base Type:	Hourly	(required)
Report Heading:	Tours	
Abbreviation:	Tour	
Enabled:	Yes	
5. Repeat for any other types needed, Close when finished.

Note: As with Site Types above, Schedules must each have their own Reservation Type (or types). Therefore make sure you have at least one Reservation Type defined for each Schedule. For instance if your Jeep tours are on different schedules than your Raft tours, then you need separate Reservation Types for each one, not just "Tours" for both.

Add one or more Schedule definitions:

1. Go to Maintenance / Park Setup / Schedules.
2. Click "Add schedule definition".
3. Enter a name for it, which will primarily be used in a pick list so it should be fairly short. Example: "Wild tour"
4. Enter a Periods name, which will be used in various places where "days" or "nights" might be used such as rates definitions. For example, "Tours".
5. If most of the reservations for this kind of schedule last a certain length of time (periods) you can set a default # periods and block-to periods. Otherwise leave those fields blank.
6. Click "Resv Types" and select the type or types of reservations (as defined above) which can be used for this schedule. Also remember that you can't use the same Resv Type for more than one Schedule definition.
7. For auto-rates, you can also specify extra periods to check. For instance if you have a 6-hour rate that's cheaper than 5 individual hours, you can set this to 2 or 3 so they're not charged too much for shorter reservations.
8. Add one or more Periods:
 - a. Click "Add Period".
 - b. Enter a Period name, which is used on the Rack, reports, etc. Keep it short!. Examples: 10AM, 8-10am, Eve., etc.
 - c. Enter a Start time for this period. The primary use for this is so the New Reservation dialog can guess what the "current" period is.
 - d. Optionally enter the # of minutes in the period. This is primarily for convenience, so it will automatically set the start time for the next period you enter.
 - e. Optionally enter the "End text", which will be shown on receipts in place of a check-out time. Example: "Due back by 10PM", "through 2:59pm", etc.
 - f. Repeat for any other periods in the day. Remember there's no need to cover all 24 hours, just the periods for which you need to make reservations.

Note: Schedule periods are assumed to never "overlap", just like days. In other words if you define an 8AM period and a 9AM period but enter 120 for their # minutes, the 120 minutes is essentially ignored. To make a 2-hour reservation on a schedule with periods each hour, and assuming that this is for a resource that must be returned before it can be used again (like a canoe), you would make the reservation for 2 periods (e.g. the 8AM and 9AM periods). On the other hand if you have a tour every 3 hours, where there is no problem with conflicts because it's not using a unique resource, then you would make the periods 3 hours apart.

Add the Sites for scheduled reservations:

1. Go to Maintenance / Park Setup / Sites
2. Click "Add New Site"
3. Enter the site details, and in particular be sure to select the appropriate Schedule form the drop-down list. Also be sure to select an appropriate Site Type. Remember that all Sites of a particular Site Type must use the same Schedule also.

At this point you should be able to see your schedules on the Rack -- just select the Site Type used for the scheduled sites, and those sites will be shown and the scheduled periods will show in addition to the dates in the column headers. There will be a column for each period defined in the schedule.

Rates for Scheduled Periods

Setting up rates for scheduled reservations is basically the same as for daily, weekly, or monthly rates.

There is one particular key to making a rate for scheduled periods -- in the drop-down for "Rate is per ___ (# of)", which normally shows Days, Weeks, Months and Years, you will see your schedule selections appear. The "Periods name" for each of your schedules will be added to the list. Once you select one of these new period names (e.g. "Tours"), then the rate is considered a scheduled-period rate instead of a daily rate.

In addition, you'll see a new field appear below the Discounts button/list, for Periods. This can be used to select which period or periods this rate applies to. Thus you can specify a different rate for each tour time, or different rates for morning vs. evening rentals, etc.

Likewise, instead of applying a rate to a range of days (Applies if >= ___ Days), it will apply to a range of periods (e.g. Applies if >= ___ Tours).

Auto-rates for periods work just like they do for daily rates. The only real difference is the setting for the number of extra Periods to check (which you specify for each schedule separately as mentioned above), instead of using the global setting for the number of extra Days to check.

Reminder -- All calculations for the number of periods is based on the list of periods you've defined, NOT on the number of hours or minutes. This includes rates calculations. For instance if you've defined hourly rates only for 8AM to 6PM, and someone rents for 6PM to 8AM the next day, then that's only 2 periods (the last period of the first day and the first period of the second day). This is where you might need to define a special rate for that 6PM period, to cover overnight rentals (or better yet, add a special "Overnight" period to the schedule to cover all of the time in between days).

Reservation Restrictions & Reminders

Overview

Reservation Restrictions can be defined with a variety of conditions, allowing some custom validation of reservation entry, either preventing certain combinations outright, showing a warning, or only allowing operators with a high enough access level to bypass them. The "Restrictions" functionality can also be used to simply show a custom Reminder pop-up message when making and changing reservations when they meet certain criteria.

These can be simple rules such as requiring 3-day minimum stays on holiday weekends or not allowing "Monthly" reservations on Tent sites, or they can be more complex conditions such as requiring a given customer to be out for 7 days between stays, not allowing more than 4 future stays, or limiting a cabin reservation to 3 days if they have more than 4 people and using a discount. (Any numeric values mentioned in these examples are completely configurable of course.)

Note that these are separate and above the standard validation checks, such as checking for double booking, reserving a site when it's marked Unavailable, requiring a site to be assigned, etc.

Restrictions vs. Reminders

This "Restrictions" functionality was primarily designed to allow blocking or warning about making reservations with given conditions. However there may be times when you don't really want to block the reservation, but want to show a reminder to the operator -- whether it's a reminder every time to "Inform the customer about cancellation policies", or a notice only for reservations that meet certain conditions, such as during a special event. A special "Reminder" flag was added to allow this while maintaining all of the rest of the same functionality for setting the conditions under which the message is shown. The only difference in creating these is whether the "Use as reminder only" box is checked. Therefore to avoid being overly complicated, trying to say "restriction or reminder" every time, the remainder of the documentation here will simply use the wording as if it's a restriction, except where specifically necessary to mention the difference.

Caveats and Limitations

These restrictions are intended to be used as reminders to the reservationist, to prevent accidentally making reservations under the wrong circumstances. They could even be used to make sure a special message is shown whenever a reservation is made during a special event, for instance. However, anyone with sufficient access and knowledge of the system could find ways to bypass them (for instance by disabling them), so they are **not** meant to be an absolute preventative measure. In addition, certain situations will not check every possible condition -- for instance if making date changes to a reservation with Guests, if date changes are required for the Guests to keep them within the host time frame, the changes to the Guests are not validated against the restrictions. Likewise when synchronized reservations are changed, only the one initially selected for the change is validated, not each of the linked ones. Hopefully it would be extremely rare that this kind of thing would cause a problem, but be aware that the restrictions are primarily for checking new reservations before they're created, and changes to the primary reservations only.

Another thing that can affect certain restrictions is splitting a reservation. For instance, if you have a 3-day minimum stay restriction for a holiday weekend, but they have to move sites so the reservation is split with 2 days on one site and 1 day on another, then both parts of the split (which are technically separate "Reservations" in the system) will be considered violating the restriction. Therefore it's good to always have an Access Level setting for allowing the restriction with a warning prompt.

Restrictions (and reminders) will not apply to reservations which are canceled, inquiries, or on the waiting list. They will also exclude reservations with the "Owner" type, since those are by definition background reservations, not necessarily occupying the site.

Restriction conditions will not count the "Block-to" dates as part of the restriction checking -- only from the First Night to the Last Night.

Restrictions Setup Dialog

Start setting up restrictions by opening the Restrictions Setup dialog ([Maintenance / Park Setup / Reservation Restrictions](#)). This will list any already defined (if there are any), with their Description, Restriction Type, and whether it's enabled. From here you can add or edit restrictions, delete obsolete restrictions, and move restrictions in the list.

You can also [Print](#) or [Export](#) the shown list at any time.

Adding or Editing Restrictions

Note that the information shown for the Restrictions in the list are coming from the Restriction Definitions -- they cannot be changed directly in the list. You need to Edit the definition to change it.

The basic procedure for defining a Restriction is to click Add restriction, and then enter the details of the Restrictions Definition including the applicable Restriction Type and parameters, along with the applicable sites, dates, etc that determine its function. Insert is the same as Add, except that the restriction will be inserted in the list at the current selection point, rather than added to the end of the list. You can edit any of the existing restrictions by clicking on the restriction in the list and selecting Edit restriction definition, or you can double-click on the restriction in the list.

Warning -- Once a restriction is edited or deleted, there is no way to Cancel the operation -- the changes are permanent once you leave the Edit Restriction dialog and come back to the Set Up Restrictions dialog.

You can Move, Delete, or Copy one or more restrictions by selecting the restrictions in the list (Ctrl-click or Shift-click will select multiple restrictions), and then click the appropriate button. Copying restrictions is very handy if you have groups of restrictions that are similar but have slight variations, such as sites or season dates.

Restriction Order

Restrictions are always checked top-down, from the first in the list to the last. While the order of restrictions won't affect how each one works, there may be reasons to put them in a certain order. For instance, you would want to put the most critical ones first (or the ones that require a higher access level to ignore or allow with a warning), so those are checked before it bothers to check lower-priority ones, especially ones that are set to "Use as a reminder only". This will reduce the number of reminders or warnings the operator will have to confirm -- you don't want to have to click through a few routine reminders and then hit a restriction that doesn't allow you to continue anyway.

Add to or Remove date(s) from Restrictions

These functions allow you to select any number of restrictions, enter one or more dates or date ranges, and will add or remove those dates from the applicable dates for the restrictions selected. It does so by adjusting the "Special Dates Applicable" or "Special Dates Not Applic." fields of the Restriction definition. It won't modify the "Season Dates" setting.

Importing and Exporting Restrictions

These functions allow copying a restrictions setup from one database to another (or between computers). This is used if you have your software provider do the setup on another system and then need to import that setup to the working database on your computer. The Import function will **only** work with files exported using the Export Restrictions function here. It cannot import restrictions from a user-created file.

The Export function creates a text (CSV) file in a special format that the Import function can read. This can include one or more definitions (select the entry or entries to export before clicking the Export button). To complete the export, select the location (Save in) and the file name for the exported file with the "Export" file dialog is shown.

The Import function is simply the reverse of Export -- select the CSV file containing the exported restrictions, and Open it to import the restrictions into your database.

Restriction Types

There are several different pre-defined Restriction Types, allowing for a variety of basic validation criteria. You can have as many different restrictions of each type as you like. While these types cannot be changed, the "Applies only to" conditions of the Restriction Definition allow a lot of flexibility, including a fully programmable "Condition expression" -- essentially allowing limitless flexibility in the types of restrictions you can create.

Remember that the Type is only one part of the definition -- in order for the reservation to be restricted and/or the warning shown, it must also meet all of the conditions specified in the "Applies only to..." section of the definition.

Always, if applies to reservation -- This is a generic restriction, which means trigger for any reservation meeting the defined conditions. So if you can define the conditions of the restriction in the "Applies only to..." section, then simply select this type to restrict all reservations with those conditions. An example would be not allowing a Monthly reservation in a Cabin -- select "Monthly" for the Resv Type and "Cabins" for the Site type, and select this Type to not allow that combination.

Minimum days long / Maximum days long -- Don't allow a reservation shorter or longer than the # days specified. (In most cases you could also use the "Applies if >= days / <= days" to do the same thing, but there are certain combinations that having this as the Type can help with.)

Maximum consecutive days -- This is much more powerful than the simple "Maximum days long" type -- this will look at all other reservations for the same customer, on any site, and sets a limit on the consecutive number of days in the park. So if you want to make sure they're not site-hopping to try to avoid the limitation on days-in-a-row they can be in the park, use this type instead of "Maximum days long".

Maximum concurrent reservations -- This limits how many reservations they can have overlapping on the same date (for instance to prevent a member from making a reservation for a friend under the same name).

Minimum days out -- This sets a requirement that they not have any 2 reservations closer together than the given number of days. By using this and also a restriction of "Maximum consecutive days", you can easily implement a rule like "Max 14 days per stay with at least 7 days in between stays".

Maximum days in the calendar year -- This sets a limit on how many days the customer can be in the park in a given calendar year. Note that this is pre-defined as January 1st to December 31st, it cannot be an arbitrary time frame.

Maximum reservations in the calendar year -- As above, but limits the number of separate reservations in a year.

Maximum days in the calendar month -- This sets a limit on how many days the customer can be in the park in a given calendar month.

Maximum reservations in the calendar month -- As above, but limits the number of separate reservations in a month.

Maximum days in a given time span -- This sets a limit on how many days the customer can be in the park in a given time span (number of days), for instance a limit of 14 days within any 30-day span.

Maximum reservations in a given time span -- Similar to "Maximum days in a given time span", but this only counts unique reservations. This would be limited usefulness of course unless you also have minimum reservation lengths, or just want to limit how many times they change sites (requiring separate reservations).

Maximum total days on certain dates -- This limits the total number of days on certain specified dates. This can be a date range (e.g. your season), or any combination of date ranges (e.g. to limit their total nights on all holidays for the year).

Maximum reservations on certain dates -- As above, counts the number of separate reservations that have at least one day covering the dates you specify, rather than the total nights on those dates.

Must include a minimum # of certain dates -- This can be useful in certain special cases, for example if you have a 5-day special event and want to make sure that any reservation during the event includes all 5 days of the event, or at least 3 of its days, etc (e.g. to prevent someone just passing through from taking up a valuable site during the event).

Must not include more than # of certain dates -- This defines a maximum number of days that can be included within a certain time frame, in the single reservation. It does **not** prevent multiple reservations for the same customer from having a combined total more than the maximum days defined.

Maximum future days reserved -- Limits how many total days they have reservations for after today.

Maximum future reservations -- Limits how many total reservations they have reservations for after today.

Minimum # / Maximum # periods (hourly/schedules) -- These specifically apply to "Scheduled" reservations, e.g. for Hourly rentals. For instance, you can set a minimum or maximum number of hours that can be in one reservation.

Maximum consecutive periods -- This is much more powerful than the simple "Maximum # periods" type -- this will look at all other reservations for the same customer, on any site, and sets a limit on the consecutive number of periods reserved. So if you want to make sure they're not site-hopping to try to avoid the limitation on periods-in-a-row, use this type instead of "Maximum # periods".

Edit Restriction Dialog

When you select New, Insert, or Edit from Restrictions Setup, the Edit Restriction Definition dialog will appear. This is where you define all of the details of the restriction.

Make sure that the desired Restriction Type is selected (this can be changed any time), and enter a Description.

Restriction Type

There are a fixed set of Restriction Types to choose from. The different types were covered in the previous section above.

Depending on the Restriction Type selected, one or two additional parameters may appear that must be filled in. This is typically the # days or # reservations for a minimum/maximum restriction, for instance.

A special case is when it's a restriction with "certain dates" -- the 2nd parameter will be "...on these dates". The entry can be a single date, a date range, or any number of date ranges. In addition, they can be dates without the year (e.g. 7/4). See the "Restriction Dates" section below for details on how these are entered.

Description and Message to show

The Description is shown in the Setup Restrictions list, so you should make it simple but also descriptive enough for easy recognition. This is also shown in the warning or error message whenever the restriction is violated.

The Message to show is more important -- this is also shown in the warning or error when the restriction is violated (or as the reminder message if "Use as a reminder" is checked), so it should be as detailed as necessary and show what you want the operator to know about the restriction violation. When you're selecting the initial Restriction Type and entering the parameters, a default message will appear here (and the Example Message, see below). However you're encouraged to customize this. You can also insert line breaks using the characters \n (backslash-n), to help make it stand out better. For example:

```
\n\n Remind the customer:\n\n           Minimum 3 days on holiday weekends!\n\n
```

This will add some blank lines above the reminder, nicely separating the message from the other information in the error prompt.

Other options

Use as a reminder only... -- If you only want this to be a reminder, without actually blocking the reservation (or changes to the reservation), then check this box. The user will be shown the defined message (unless their access level is at or above the Ignore level, below), with simply an "OK" button. However it will not abort the reservation or changes.

Only check new reservations... -- If you want this restriction to only be checked when a new reservation is created, then you can check the box "Only check new reservations, not subsequent changes". This could be useful for instance of you're using the restriction just to show a reminder when reservations are made on certain dates -- no need to keep reminding every time something is changed.

Use Example message -- The Example message shows a canned message generated from the Type and parameters. This will be used by default for the message shown for the restriction, unless you manually change the Message. However if you decide to use the example again, you can click the Use Example Message button to copy the Example message to the "Message to show".

Ignore without warning for Access Level -- If the operator has this access level or higher, the restriction will be ignored. This is usually set to "Nobody", which means it will not be ignored for any operator, even Administrators.

Skip showing reminder for Access Level -- (If it's "Use as reminder only".) If the operator has this access level or higher, the reminder message will not be shown. If below this level, the reminder is shown.

Allow (with warning prompt) for Access Level -- If the operator has this access level or higher, and assuming the restriction is not ignored (above), then a warning message will be shown with an option to allow the reservation anyway. For any operator below this access level, an error message will be shown without an option to bypass the restriction. Note that this option is not available if "Use as a reminder only" is checked, since there is no reason to ask whether to continue or not.

Warn only once (or Show only once) -- If this is set, then when making linked reservations it will show the warning & option to bypass only once (for that particular restriction). This does not prevent it from being shown again for subsequent changes, etc -- only for linked reservations all being created at once.

"Applies only to..." Filtering

This is the most important part of the setup.

The rest of the dialog entries are used to "qualify" a restriction. This determines whether the restriction definition applies to any given reservation, so it's important to get this set up properly.

Resv Types

You can select one or more Reservation Types for which the restriction applies. Click the [Resv Types](#) button to open a list of reservation types, and select any that are applicable. For instance, you may have different restrictions for Monthly reservations than your Normal reservations. As with any of the lists here, an empty list (selecting nothing) means that it will apply to **all** types -- in other words, "not filtered".

Site Types, Site Classes, or Sites

If this restriction only applies to certain Site Types, click the [Site Types](#) button and select the applicable types from the list that appears. If no site type is selected, the restriction will apply to reservations of any site type (assuming other filters don't exclude it). If you select one or more site types here, then that restriction will only apply when a reservation is for one of those site types.

Likewise, you can have a restriction apply to specific Site Classes, using the [Site Classes](#) button, or even one or more specific sites using the [Sites](#) button. However you don't need to set all three (types, classes, and sites) -- usually only one of these selections is enough to sufficiently qualify the restriction. For instance if you select "Normal RV" for the Site Type, there's no need to select "RV's" for the site class because it's redundant -- all "Normal RV" sites will have an "RV's" class anyway, so there's no need to make the restriction check this too.

Only applies if NO site is assigned

This is a special-case option. If this restriction should **only** apply if there is no site assigned, you must check this option (since there is no way to specify "no site" with the other selection lists).

Discounts

If you offer discounts, such as Senior discounts or Good Sam membership discounts, then you can set up special restriction definitions for them. Filter each restriction definition for the appropriate discount(s) by either selecting one or more discounts from the [Discounts](#) list, or by checking the [Only applies if no discount used](#) check box if it should only apply when no discount is used. As with Site Type, this will determine whether the restriction will appear in the restriction selection list for a given reservation.

Applies if ... days

You can set up the restriction to apply only if the reservation is longer or shorter than a given number of days, by setting the [Applies if >= days](#) and [Applies if <= days](#) fields.

Applies if reservation field...

The [Applies if reservation field...](#) selection permits a great deal of control over when a restriction applies. This specifies that the restriction applies to a particular "preference" setting in the reservation or one of the "# of" or value fields such as number of adults, extra vehicles, or rig length.

To use this option, select a reservation field from the list. Some numeric fields are also available in additive combinations also, primarily to allow "# Adults + # Children" to be selected if it's based on the total number of people.

If the field is an attribute/preference field, such as "50A", then you can specify whether the restriction will apply only if that preference is "true" (set to "Must Have") for the reservation, or whether it's "False" (not set or set to "Must Not Have" are both considered false in this case). Therefore you can set up two separate restrictions that are mutually exclusive, one for the True case and one for the False case of the preference field.

If the field is a numeric value, additional settings will appear that need to be entered. You will first enter a value for "is >=" ("is greater than or equal to") to indicate when the restriction applies.

Adding new fields -- If you need add your own fields for use in restrictions like this, then note that they must be tagged as "Attrib" fields in order to be selectable from this list. See the special note about Attribute Fields under the **Adding New Fields** section of the Data Field Definitions topic.

Advanced Condition Expression...

If the restriction can't be properly qualified using the other Applies-if conditions, date selections, etc, then you can use Expressions to create a condition as complex as needed. Note that this involves the Advanced Customizations functionality and is only recommended for very technical users, so refer to that section for more detailed information.

If a Condition Expression is entered here, it must be satisfied (result in True) in addition to all other conditions in the restriction definition in order for the restriction to be used. Thus you can use the other Applies-if conditions to handle the simple stuff, and use the expression to only do the filtering that can't be otherwise handled by the restriction definition.

The expression will have **ThisResv()** context which will be the specific reservation being checked (e.g. if there are 5 synchronize reservations being added, this expression will be executed for each reservation individually). In addition, **ThisFromDate()** and **ThisToDate()** will indicate the date range of the reservation as well as **ThisFromPeriod()** and **ThisToPeriod()** if it's an hourly/scheduled reservation). **IMPORTANT** -- The reservation in **ThisResv()** will usually be a temporary copy of the reservation, not the actual record in the database. While this won't matter in most cases, be aware that it could appear as a duplicate to one in the database, especially if the restriction is being checked for changes to an existing reservation.

Restriction Dates

You can define the dates for which any restriction is applicable. Defining dates for a Restriction definition is just like defining dates that a Site is available or Rates are applicable (see Edit Site Details or Edit Rate Definition).

Notes

The Notes field is just for your own notes, perhaps an explanation of why a restriction is set up the way it is. The Notes are never seen by the customer or by an operator selecting a restriction. The notes can be any length.

Setting up for Electric, Gas, and Water Meters

There are a few different areas you need to address when setting up the software for reading meters and adding charges to the reservations. A brief overview was given in the *Setting up your Campground Database* section, but here is a more detailed step-by-step guide.

This guide will mention Electric Meters specifically, but the same steps apply to Gas or Water -- just substitute the appropriate field names, rate types, etc. as appropriate.

Data Field Definitions

First you need to make sure the Site fields are enabled, through Data Field Definitions.

1. Go to Maintenance / Data Field Definitions / Site Fields.
2. Locate the 3 fields associated with Electric meters -- Site_Meter_Last, Site_Meter_Date, and Site_Meter_Resv_Link.
3. Change the status to Enabled for all 3 of these sites (click on "Disabled" under Status and select "Enabled").

Second, you need to enable the Park field for the wrap-around number for your meters.

1. Go to Maintenance / Data Field Definitions / Park Fields.
2. Locate the "Wrap" field associated with the meter type you need -- Park_Wrap_Electric, Park_Wrap_Water, or Park_Wrap_Gas.
3. Change the status to Enabled for any of these you'll need for the meter types you use (click on "Disabled" under Status and select "Enabled").

Transaction Category

You need to enable or add the appropriate category for the charges.

1. Go to Maintenance / Pick Lists / Transaction Categories.
3. Check "Allow editing of fields".
4. Locate the category you want to use ("Electricity" or "Gas" or "Water"). If you don't see one that you want, add it by clicking "New Record" and enter appropriate text for the selection name, report heading, and abbreviation.
5. Change the Enabled status to "Yes".

Meter wrap-around numbers

Next, you need to enable the "wrap" field and set the wrap-around number for your meters.

1. Go to Maintenance / Park Setup / Parks.
2. Enter the Meter wrap-around number for Electric meter. This is almost always a 1 followed by 0's equal to the number of digits in the meter (enter 100000 for 5 digits, 1000000 for 6 digits, etc.).

In the simplest case, all meters will wrap at the same number, e.g. 10000 if it's a 4-digit meter, meaning that after 9999 it will turn over to 0, so 10000 = 0. However you might have more than one type of meter with different numbers of digits. If you happen to have two different types of meters, with different numbers of digits, then you can override the wrap-around numbers for individual Sites. See *Edit Site Details* for more information. Tip -- put the most commonly used wraps in the Park record, to minimize the number of sites for which you have to enter individual settings.

Enter previous/current meter readings (or correcting a reading)

In order for it to calculate the electric usage, it needs to know the previous reading for each site before you enter the new readings. To do this, you need to go into each Site and enter a reading.

1. Go to Maintenance / Park Setup / Sites.
2. Select the first site (or the first one that has a meter) and click Edit site details.
3. Enter the Reading, under Electric Meter Last. There's no need to enter a date at this time, since that will change automatically when you enter the new readings.
4. To quickly go through all of the sites, you can use the Next button instead of Saving and Editing each time.

Meter Rates

Now it needs to know how much to charge for each kilowatt-hour of the reading. Some situations require complex tiered rates, for which there are step-by-step Rates Examples, but here's the basic procedure for creating a flat rate per kWh.

1. Go to Maintenance / Park Setup / Rates).
2. Click [Add rate definition](#).
3. Select "Electric Meter" in the [Rate Type](#) field.
4. Enter "Electric meter" (or whatever you want) in the [Description](#) field.
5. Click the [Charge](#) button.
6. Select (click on) "Electricity" from the drop-down category list (or whatever category you might have added for this).
7. Press the **Tab** key to change to the [Description](#) field, and change it if you want (e.g. "Metered electric"). Keep in mind that the current and previous readings will automatically be added to this description on their receipt, for instance "Metered electric (2500-2200)".
8. Press the **Tab** key twice to get to the [Each](#) field (no Qty is necessary).
9. Enter the amount per unit, not including taxes, for instance ".0623". Notice that you can include the fractional cents as added decimal places. It will show up to 4 places in the dialog, but the number will actually be stored and used for calculations exactly as you enter it.
10. Press the **Tab** key to accept the amount.
11. Check the boxes for one or more taxes under [Auto-add tax](#), if they apply.
12. Click the [Save](#) button.

Entering readings & adding the appropriate charge -- Single Entry

Using the Batch entry report (below) is preferred even for one entry -- it keeps better historical information that allows you to "undo" an entry and charges if needed. However you can also enter a single reading and have it calculate the charge for the reservation through the normal Reservation Transactions dialog. Click on Select Rates, and then select the appropriate Rate Type (e.g. [Electric Meter](#)).

If you have just a single rate for the amount per kWh, for instance, just double-click that rate (or select it and click "Add"). A simple dialog will appear showing the old reading and asking for the new meter reading. Just enter the new reading and click Save. The Site record will be automatically updated with the new reading, date, and reservation, and the appropriate charge will be added to the reservation.

If you have multiple rates, either because you have both a base rate and a per-unit rate or you have multiple tiers, you would need to choose each rate that applies and add it separately. In that case, it's probably better to just use the [Batch](#) entry method below even if you're doing it for just one reservation, since it will be more automatic and less error-prone.

Entering readings -- Batch entry

To enter many new readings at once, go to Reports / Electric Meter Readings. With the default settings you might not see your sites or their occupants, so there are a few things you should do to configure this:

1. Go to Reports / [Electric Meter Readings](#)
2. Make sure [Filter by last reading date](#) is not checked.
3. Click [Select Resv Types](#), and highlight all types that you might need to enter readings for (e.g. Normal and Monthly), and click OK.

Now you should see all sites that you had entered previous readings for above, and any with current reservations will show an occupant name. To enter readings and put the charges on each reservation, just fill in the new readings under Batch Reading Entry and click [Add Charges & Update Readings](#). For more details, see the help/documentation on the Meter Readings report.

Pick Lists

Pick Lists are the tables of values used to make data entry quicker. In addition, they are useful in limiting possible values for certain fields so that data integrity is assured, and so that meaningful categorized reports can be generated. The pick lists for site attributes also help categorize sites to make site selection easier.

A new database is initialized with populated pick lists that serve as a guide. While some of the entries may be useful, you will likely want to remove and change some, and add some of your own. This is done easily through [Maintenance / Pick Lists](#). A pick list may be any length, but use discretion when filling them -- long lists are more difficult to choose from, and can cause problems displaying the list in a drop-down box if your screen is too small.

The order of the items in each pick list is important -- this is the order in which they will always appear in the drop-down lists or other selection lists. Besides making the order logical to the operator, you will want to pay attention to the first letters of the items, because those can be used to quickly select the items. You can try to make each first letter unique, but if that results in confusing names then the next best would be to put the most-used items toward the top. Or instance, if you have "Tent" and "Trailer" in the Rig Types list in that order, pressing **T** will select Tent, and pressing **T** again will select Trailer. If you use Trailer much more than Tent, you might want to switch the order so that Trailer comes up first. (Or in this case you can just remember that **TT** means Travel Trailer, a convenient coincidence since TT is often an abbreviation for Travel Trailer.)

Note: If you already use QuickBooks and plan to export transactions to QuickBooks, you may want to base your setup of Transaction Categories and Payment Methods according to your QuickBooks accounts, to make the transactions in Campground Master map easily to your existing accounting system.

Changing Pick Lists

You can add pick list items any time you like. So if you add cabins to your campground, you can easily add a Site Class and/or Site Type for cabins. You can even insert it into the list anywhere you like, since the order of the lists don't matter to the database -- it won't cause problems with existing records. The Index field is the important part (that's how the pick list items are referenced), and you will see that when you move pick list items around in the list, their Index stays with them. When you add or insert a new item, a new unique Index will be generated for it automatically.

IMPORTANT! Once the pick-list is in use you should *never* change the names of pick list items to something that has a different meaning, and you should never delete a pick-list item that might be in use. (Note that when a pick list item is deleted, its Index is discarded and cannot be re-used, so there is no way to get it back short of restoring the database from a backup!) Of course if you're *sure* that an item has never been used in a database record, then it would be safe to delete or change it. If you stop having a need for one of the items (for instance if you no longer accept one of the payment types), the best thing to do is to just Set the [Enabled](#) field to "No". It will then be removed from commonly used selection lists, but will still be shown on reports if there is data associated with it.

On the other hand, you are free to change the text for any pick list item. As long as it still represents the same thing, it won't cause any harm. The new name will be shown in any existing records that used the pick list item automatically (because the Index field is unchanged), so feel free to make changes like "highway sign" to "road sign" or "billboard". But don't make changes like "Visa" to "Discover" -- use the Move Up and Move Down functions instead, if you just need to change their position.

Pick List Dialog Functions

Each of the Pick List editing dialogs consists of a grid with the pick list table and some controls at the top. The controls are detailed below.

Warning! -- All changes made in this dialog are permanent and immediate, there is no way to cancel them!

Allow Editing of Fields -- This is simply a safeguard against accidental changes. By default, all of the dialog's controls except **Print** and **Close** will be disabled, but you can look around the table. If you plan to make changes, check this box so that the controls are enabled and you can make changes in the grid. Note: leading and trailing blank spaces will be automatically trimmed from all entries after editing.

New Record -- This will add a new pick list item to the bottom of the list and move the cursor to it, ready for typing.

Insert Record -- This is used to insert a new item in the list somewhere other than the bottom. First click on the item in the grid that you want the new item to be *in front of*. Click **Insert**, and a new pick list item will be added at that point, moving the others down.

Move Up and **Move Down** -- Use these to move items in the list to new positions. Just click on the item to move, then click the **Move Up** or **Move Down** button.

Print List -- This will print the pick list grid. It uses all of the same print options as used for the other grids (tab views, etc.).

Delete Selected Record(s) -- This will delete (permanently!) any of the items selected in the grid. Just select one or more items (using **Shift-Click** to select a range or **Ctrl-click** to select multiple items), and click the **Delete** button.

Close -- closes the dialog. Since all changes were already made immediately, there is no **Cancel** option.

The Grid -- This is the list of pick list records (items). If editing is enabled, you can edit any text (except the **Index** field) by clicking on the cell and typing (which will replace the existing text with what you type), or by double-clicking on the cell to enter edit mode (where you can edit the text without deleting it). Note that while you are in a cell, you can abort the changes by pressing the **Esc** key. Once you leave the cell, however, the changes are permanent. Any cells that have been changed will be shown with a light yellow background.

You may notice that the grid can't be sorted by a column the way most other grids can. This is because the order of the items is important, and sorting (even temporarily) could cause confusion when adding items to the list.

Pick List Fields

Index -- This is the software-generated unique identifier for an item. It cannot be edited.

Selection Name -- This is the text normally displayed in drop-down lists on dialogs, etc, and as the value for the field. It should be limited to about 10 or 12 characters so that it fits in the drop-down lists without being truncated.

Report Heading -- This is the text normally displayed on reports as row & column headings, e.g. when grouping by the pick list value.

Abbreviation -- This is a short version of an item name. It's only used in a few places where space is short, such as the **Requests** column on the **Arrivals** tab and the **Type** column for sites on the **Rack**.

Notes -- This can be a long description, for your own reference.

Base Type -- This is used in the Reservation Types and Payment Methods pick lists only. See below for details.

Enabled -- This can be used to disable items that were used in the past (and thus can't be deleted), but you don't need anymore for future reservations, etc. Disabled items will not be shown on selection lists (unless it's the currently set value), and won't be shown on summarized reports (unless there's a non-zero amount for that item).

Ref Needed, Qty Needed, Fixed Each, and Each -- These are used in the Payment Methods pick lists only. See below for details.

Rig Types Pick List

This is used for the customer's Rig Type field. You can define them to be generic (RV, tent, boat), or you can be more specific (Fifth wheel, class A, diesel, etc.). It all depends on how specific you want your records to be or what information is helpful to you for making reservations. You may want to include a "none" value to be used for guests or if you have cabins, etc. where there is no rig needed. Future software versions may support rig type categorization or filtering for reports, so keep that in mind as well.

Site Types and Site Class Pick Lists

Site Type is the most important of the site attributes, since it's used on nearly every report for filtering sites and is also used as the basic criteria for selecting appropriate sites, and possibly for determining the rate of each site. The design of this list can vary greatly for different campgrounds. Selections can be as generic or specific as you like, but keep in mind that the longer the list is, the more awkward it will be to use. Design a list that will be useful for filtering and provide useful reporting categories, and that would work well in the tab views where you can select only one site type.

Remember that there are a number of site attributes that can be used to narrow down a search, so you don't need to have separate Site Types for every combination of 30A/50A, pull-through, sewer, pad type, etc. On the other hand, if all of your sites are basically the same except that some are pull-through and some are not, and perhaps some of the non-pull-through sites have only 30A, then that's only 3 different combinations and would be very manageable as 3 Site Type selections. But if you have more than 5 combinations of site features, then it may not make sense to use each combination as a different Site Type.

Site Class is another site attribute that can be used for selecting a site (in a reservation's site preferences). Site Classes are typically a more broad category, and Site Types are more specific. So you might have "RV site" as a Site Class, and "Powered" and "Unpowered" as Site Types. Cabins, Units and Bungalows could be all one Class of "Room", or they could be 3 separate Classes (especially if you also needed to break them down further, e.g. 1-bed cabin, 2-bed cabin, etc.)

There are 2 main uses of types and classes:

- Selecting a site (e.g. what their criteria is -- do they just want any type of RV site (select by Class) or do they need a Powered one (select by Type).
- Rates -- this is generally best to do by Site Type, so for instance if you have 3 different rates for different types of RV sites, then you would want to set up 3 Site Types for those.

You can do most reporting by either Type or Class, so keep that in mind also.

Pad Types Pick List

This is a site attribute that can be used for selecting a site (in a reservation's site preferences). Pad Type selections would typically refer to the type of material that an RV parking space uses, such as grass, gravel, concrete, etc. Pad types usually refer to RV sites, but you could also include useful selections for cabins (bed type?) or other types if needed.

Site Facing Pick List

This is a site attribute that can be used when making a reservation (site preferences), if the customer has a preference for which way a site faces. It is initialized with common directions (North, West, Southeast, etc.), but it could be used it for something more descriptive, replacing the directions with something like "Lakefront", "Pool", "Golf", and "Playground". (There are other attribute fields in the Site table that could handle this as well, but if direction is not a concern then this may be a better way to handle other attributes.)

Discounts Pick List

This list is used for the Discount-Used field of charge-type transactions, to indicate what discount was used in the calculations (and of course for the Discount transactions themselves). Just include an entry for each type of club discount you accept, plus anything else applicable like Seniors, Students, and perhaps one for Other (you never know when you might give a discount just because the poor guy looks like he's had a bad day.)

Payment Methods Pick List

This list is used for the pay method in any payment-type transactions. Simply include the different types of payment that you accept, to the extent that they are useful for reporting or keeping track of how a bill was paid. You can include anything from credit cards to green stamps if it helps. It's usually a good idea to include the different types of credit cards (Visa, Discover, etc.) rather than one "credit card" field, for the sake of reporting. If you take multiple currencies, you might even want to distinguish between U.S. and Canadian cash, for instance.

In addition to the name and description fields, there are 4 special fields that should be set according to the payment type. The Base Type field, Ref Needed field, Qty Needed field, and Fixed Each field help determine what additional information is needed for each payment method when entering the payments. For instance, if "Credit Card" is selected for the Base Type, then the credit card entry fields will be enabled. If Qty Needed is set to "Yes", then the Qty field will be enabled. This is useful for coupons or other payments that have specific values. In addition, you can set the Fixed Each field and specify an Each value for the payment method, in which case only a Qty is needed when entering the payments. This is useful for membership coupons with fixed values, for instance.

How Heard Pick List

This list is used in the reservation records, and is simply to indicate how the customer heard about the campground, or if they are returning customer. It's used primarily for tracking advertising results, in the How Heard Report. This list can get fairly long if you include every possibility, but if that's the information you need then you should let it be long and specific. If you don't do any advertising and only want to know whether they are a return visitor or not, you can use it for that too.

One unique feature of this list is that there should **always** be an item with "Return visit" as its Name text. It doesn't matter where it is in the list or even what Index it has, it just needs to have that exact text (without the quotes of course). This will allow the "Return Visit" item to be selected automatically for a reservation when you select an existing customer from the customer database. It won't break anything if you don't have that selection, but you would lose that bit of automation -- the How-heard field would just need to be selected manually.

Transaction Categories Pick List

This list is used for the Category field of most transactions. It should include various categories for the types of charges, plus any categories you need for Expense and Misc. Income. You may want to keep these from overlapping each other or the charges categories, so they can all appear as separate ledger categories.

In order to handle sales/lodging taxes correctly, you should have specific entries here for your taxes. For instance, have a "Lodging Tax" category for the tax, rather than lumping the tax into the categories like "Daily Rate". Also, we recommend that you set up separate categories for different taxable sales. For instance if your cabins are taxed at a different rate than your tent sites, don't just have one "Daily Rate" category -- you should have a "Daily cabin" category and a "Daily tent" category, so reports will separate the amounts. This will make it much easier to do your quarterly tax reporting from the category reports.

Note that there are some hidden transaction categories with "Reserved" names, matching each of the internal transaction types (Discount, Payment, Refund, etc.). These won't be shown, but if you try to add a type with the same name then you will get an error message.

Estimated Arrival Times (ETA) Pick List

This list is for easy selection of an arrival time for reservations. Unlike other pick list selections, the ETA is actually a free-form entry field. The list defined here is just "suggested" values, allowing selection with the mouse instead of typing it. This list can contain whatever needed, including generic entries like "Early", "Late", or "Unknown". The default selection (when making a new reservation) is defined in the Program Options.

Reservation Types Pick List

Each reservation must have a Reservation Type, which is selected when making the reservation. Originally these types were fixed, but now you can rename them and add additional types as needed. This is a very special list, because each type must be associated with a Base Type. The Base Type is used by the program in various places so it knows how to handle each reservation type, and how it will be color-coded on the Rack and other views. For instance, Monthly types are handled differently for auto-rate calculation and monthly billing, Guest types are only used for adding people to an existing reservation, etc. For a detailed explanation of the different types, see Working with Reservations.

By default, this list has one type defined for each Base Type. If you don't need a type, you can delete it from the list or set the Enabled field to "No" to disable it. If it's disabled, it won't show in the drop-down selection lists for new reservations. However it will still appear in filtering lists and reports. If you've ever used the reservation type, or plan to use it in the future, you should not delete it -- just disable it. However if you have never made reservations for a particular type, it's safe to delete it.

While base types can be useful for rates selection and reporting, be careful in defining too many types. For instance, you could define a Daily and a Weekly type to help with rates selection. However this could cause confusion if the person stayed longer than expected (say 8 days instead of 5). While you can change types later, it adds an extra step to remember. A more appropriate use for additional types might be to add a "Seasonal" type that acts like Monthly but has a different rate schedule. Or perhaps adding a "Drive-through" type that's similar to a Day Pass but has a different rate charge.

Cancel Reasons Pick List

When you cancel a reservation, in addition to selecting the "Type" of cancellation, like No Show, No Stay, Mistake, etc, you can also select a user-definable Reason from this Pick List. The distinction is that the "Type" is also the Status, and also determines the color -- it's more of a general explanation of how the reservation was canceled. The Reason can be as specific as you like. A number of common options are present by default, but you could add anything you need, such as "Hurricane Harvey" or "Highway construction".

The Reason selected will show on the Non-Reserved tab view, and can be used for the Unfulfilled Statistics Report. It can also be used for Reservation Filtering of any report that supports that filtering.

Inventory Item Classes Pick List

This pick list is only present if the P.O.S. option is enabled. See the P.O.S. Setup section for details.

User-defined Pick Lists

If you want to create your own Pick List, e.g. to use in a custom field you've added, you can do so through User-defined Tables (a Pick List is really just a special-purpose Table). See that section under Advanced Customizations for details.

Data Field Definitions

The Campground Master database allows flexibility in what information is stored, both for future expansion and to minimize the amount of "useless" information presented. The Data Field Definitions function in the Maintenance menu allows many of the pre-defined data fields to be disabled or enabled to fit the customer's needs. Some of them can also be redefined for further customization (particularly the Attribute fields for site attribute/preferences).

Modifications to the data fields can be dangerous and should only be attempted if you're very familiar with the function of the fields and what they might affect, and fully understand all of the information here. An Administrator access level is required to access these lists, and if you're using Networking then this function is only available on the master (server) computer.

Each of the Field Definitions dialogs looks the same. They are simply grids with buttons for Print List and Close. Unlike the Raw Data Table and Pick List dialogs, there is no "Allow Editing" safeguard -- all changes are immediate!

Each data field definition consists of the following elements (treated like fields in a record or pick list):

- Field ID** -- This is not editable, and is the way the field is identified internally to the software.
- Type** -- Only shown if the "Show field type" box is checked. This is not editable, and shows the data type for the field.
- Status** -- This is either "Fixed", "Enabled", or "Disabled" (see below).
- Justif.** -- Show data as Left, Center, or Right justification by default
- Field Name** -- The name of the field as usually seen in maintenance functions (e.g. selection lists).
- Short Label** -- A short name for the field, used on dialogs and places where space is tight.
- Report Heading** -- A typical heading, used on reports, receipts, etc.
- Notes** -- A longer description for the field, for your own reference.

The main item of interest is the Status. If it's "Fixed", that means the field is enabled permanently and cannot be changed. Many fields are set this way by default because the program logic depends on them. If the status is "Enabled", then the field will be visible and usable by the software, and if it's "Disabled" then the field will be ignored by the software. A disabled field will not show up on the Raw Data Table dialogs or on data entry dialogs.

Some fields are Disabled by default. This is because some fields are not needed by most campgrounds but can be enabled if needed. This includes many of the less common attribute fields, and some features like metered water, etc. You can change the status to Enabled if you need them.

Some of the fields enable or disable not only the data entry but a lot of associated functionality as well. For instance, if you enable the Site "Dirty" field, then you also enable the associated functions and display options that go with it -- menu functions to mark it dirty or clean, columns to show it on the Rack and other reports, options to automatically set the flag and warn if it's dirty on check-in, etc. Enabling the Shift fields adds functionality for shift changing and reporting (more on that later). Enabling the Reservation "Label" field allows you to change what shows on the Rack for a reservation, and gives you another way to search for reservations.

The most commonly used fields are Enabled by default, but you may want to Disable fields that you're not interested in. In most cases, disabling a field will simply remove its field from dialogs and reports (resulting in less clutter and faster data entry). In a few cases, it will also remove associated functionality. For instance, disabling the Guests field from reservations would remove the Guest Management functionality.

WARNING -- All changes to the data field tables are instant and permanent! Text changes cannot be canceled or undone. More importantly, while it's easy to change the status back and forth between Enabled and Disabled, **any data that was stored in a field will be cleared as soon as you change it to Disabled.**

P.O.S. Note: If the P.O.S. option is enabled, then there will be additional menu selections for the inventory and vendor records, etc. See the P.O.S. Setup section for details on those.

Customizing Attribute Fields

This is one area of field definition where it is safe and encouraged to set them up to meet your campground's needs. But there are several rules to follow.

The most important rule is that this applies only to fields that have a Field ID starting with **Attrib_**, plus a few fields that start with **Resv_** that have also Site attributes. These fields are recognized by the software to be attribute fields, and will show up in both the Site Preferences list from New Reservation dialogs and the Site Attributes list from the Site Setup dialog. The same Field ID's are used in both the Sites table and the Reservations table, although the reservation fields would more appropriately be called "preferences" rather than "Attributes".

The next rule is to make sure that the Attribute fields in the Site data fields table matches the Attribute fields in the Reservation data fields table. This means that the same ones must be enabled in each table, and that they should have compatible names (the Field Name text). We say "compatible" names because they don't have to be exactly the same text, but should make sense as an attribute/preference pair. For instance, you may have a site attribute of "Has Patio" and a corresponding reservation attribute of "Needs Patio".

Exception: Minimum's -- Some attributes which are normally Maximums, like Max Rig Length, also have a Minimum. Since there's only one Reservation field for Rig Length but two separate Site attribute fields (for Max and Min), there will be a "Attrib_Rig_Len" field for the maximum plus an extra field "Attrib_Rig_Len_Min" for the minimum. Note the only difference between the max field and the Min field is the extra "_Min" at the end. Likewise there are both minimum and maximum fields for # Adults, Children, Pets, Extra Vehicles, and Trailers. Of course if you change the field names to alter the meaning of these, e.g. change Trailers to Boats, then the min/max attributes will apply to that new meaning.

Now that you know the rules, here's what you can do. You can disable any of the attributes that don't apply to your campground, to shorten the list of options for the operator to choose from. You can also change the text for any of them to make them more applicable, within reason. You should **not** change the Site Type field or Site Class field. Also be aware that if you change the ones that appear in the dialogs separately, like the Site Facing, Pad Width, etc. that appear on the Site Setup dialog, the dialog text for the field name will not change, so it could be confusing. The names and text definitions of the others can be changed as needed. You can also add your own attribute fields -- see "Adding New Fields" below.

What you **can't** do is change any of the field types. Therefore you should know the field type before changing what it's used for. There are several fields of each type (size fields, yes/no fields, and ratings fields) so that you should be able to find enough to suit your needs. You could even modify the pick-list fields normally used for Site Facing and Pad Type if you need different pick-list attributes, such as "bed type" instead of pad type.

Other Customizable Reservation and Customer Fields

Some of the customer and reservation fields can be renamed if needed for special data entry. The new name should be put in the "Field Name", "Short Label" and "Report Heading" columns, and the new name will be used wherever that field appears on data entry dialogs, report headers, and receipts.

Note that the functionality of the fields does not change, so the customizability is somewhat limited. For instance, a Phone number field will still act like a phone number (e.g. for searching, formatting, sorting, etc.), but you can make changes like renaming "Phone 2" to "Cell Phone". Likewise, the "# Adults" field will still be a numeric field and still gets auto-copied from customer records to reservation records, but you may prefer to rename it to "# Over 18", or you could use it for another purpose like "Meals per day".

The following customer fields can be renamed: Cust_Phone_1, Cust_Phone_2, Cust_Phone_3, Cust_Adults, Cust_Children, Cust_Pets, Cust_Pets_Desc, Cust_Vehicles, Cust_Trailers, Cust_Emergency, Cust_Rigtype, Cust_Rig_Length, Cust_Rig_Model, Cust_Rig_Color, Cust_Rig_License, all of the Cust_Car_Model/Color/License fields, and Cust_Drivers_License.

The following reservation fields can be renamed: Resv_Adult, Resv_Children, Resv_Pets, Resv_Vehicles, Resv_Trailers, Resv_First_Date, Resv_First_Night.

Since some of the fields are auto-copied between customer and reservation (e.g. Resv_Adult and Cust_Adults), the corresponding fields should both be renamed accordingly.

Adding New Fields

For further customization, you can add new fields to a table using the Add New Field button. This will open a dialog where you can enter the necessary information. Adding a field allows for keeping track of more information, but keep in mind that the program will not automatically know what to do with any custom fields you add. It's up to you to set up any custom Dialog entry fields needed to get information into the field, and to create custom Queries, Forms, etc. as needed to show the data once it's entered. Adding a new field is only helpful if you also use the power of Advanced Customizations to make use of it.

Any added fields will have a "Type_User_" prefix, where "Type" is the record type like "Resv" or "Cust". You will simply add the unique part of the field, e.g. "Member_ID".

A field can be any basic type (text, number, date, etc.) and some "Fixed list" types.

It can also be a Pick-list item or Link to another record, but only if a custom Relationship has been set up and a User-defined Table has been created for the record being linked to. For Pick-List and Link field details, refer to Advanced Customizations / User-defined Relationships.

Adding Attribute Fields

There's a special way to create a field that is recognized as a Site Attribute or Reservation Preference. Start the Field Identifier with "Attrib_", and it will be recognized as an attribute, and thus will be automatically included in the appropriate places like the "More Preferences" list, as a Quick-Prefs option, and other places where attributes and preferences can be used such as Rates definitions. For instance, add a Reservation field with the Field Type of "Request/Attribute" and enter "Attrib_Non_Smoking" for the field identifier (the complete ID will be Resv_User_Attrib_Non_Smoking), and it will be treated as an attribute. (Note that the Field Type of "Request/Attribute" must be used to make it available as a Quick-Prefs option.) The only other field types that can be used for custom attributes are the ones starting with "Number : " -- e.g. "Number : Rating (1-5)", "Number : Signed Integer", "Number : Floating Point", etc.

Matching Reservation/Site attributes -- If you want a custom site attribute to be automatically checked against a Reservation's preference (e.g. if Use Pref's is checked when making a new reservation), you need to have matching field identifiers as discussed in the documentation for Edit Site Details. Since user fields always have Site_User and Resv_User at the beginning the fields it's obviously not possible for them to exactly match, but the program allows for the Site/Resv difference on user fields. For instance in the Non-Smoking example above, after you add the Reservation field as described, go to the Site Fields and add a field with the type "Boolean (Yes/No)" and a field identifier of "Attrib_Non_Smoking" (the full name will be Site_User_Attrib_Non_Smoking) to match the reservation field. Note that a Site field type of Boolean must be used to match up with the Resv field type of Request/Attribute. Now you can set the Non-smoking attribute through Site Details, and when you choose Non-smoking as a reservation preference, only those sites with that attribute set to "Yes" will be shown. If your Reservation Attribute is a "Number" field type, the Site Attribute must also be the same "Number" field type.

Minimum Attributes special handling -- If you need a numeric Site attribute that's checked as a Minimum against an equivalent numeric Reservation field (rather than the normal assumption of a Maximum), you need to add "_Min" at the end of the Field Identifier. The program will interpret Site attribute fields with the extra "_Min" as the minimum for a Reservation field with the same name without the "_Min", and you can have both a minimum and a maximum. For instance you can add a Reservation field of "Attrib_Slides", and then add Site fields of "Attrib_Slides" (as the max) and "Attrib_Slides_Min" as the minimum. All of these fields should be a "Numeric" type. As mentioned above, ignore the fact that it will add "Resv_User" and "Site_User" to the beginning. **Don't** be tempted to add _Max to the maximum, that won't work! A numeric field without a "_Min" suffix is always assumed to be a maximum.

IMPORTANT -- All enabled fields take database space even if they're not used, so don't add fields unless you really need the information and have no other way to do it. For instance, don't add a "Full name" field to customers if it's just going to be repeat information (combined First and Last names).

Fields cannot be deleted and the type cannot be changed. If you do add one and later decide it's not what you want, just change its status to Disabled. All data that was in the field will be cleared and it will no longer take up and space in the database.

Shift Functionality

If you need to enable the functionality for Shift reporting (for instance if you have 2 or 3 shifts per day and need reporting based on shifts, rather than days), then you need to enable two specific fields.

- In the Parks field definitions, enable the **Park_Shift** field.
- In the Transactions field definitions, enable the **Tran_Shift** field.

With these enabled, the Shift Change and Shift Report functions will be available on the Maintenance menu, and the Shift filtering and summarizing options will be present in the Transaction tab view filter and options.

Receipt # Field

There is a receipt/invoice number field in the Transactions table, which is set according to the formatting specification in Program Options. This can also be printed on receipts, and is especially useful for point-of-sale receipts. By default, this field (**Tran_Invoice**) is called "Receipt #". However you can change the Short Label and Report Heading for this field to anything you want (like "Invoice #", "Reference", etc.), and the text will be changed accordingly anywhere it appears in the program.

Reservation Label Field

The Reservation field "Label" is disabled by default, because it's important to know how to use it before enabling it. See the notes in the Reservations section for more details

Site "Dirty" Functionality

The Site field "Dirty" is disabled by default because it's primarily useful for motels and inns, so most parks don't need the functionality. When it is enabled (through Data Field Definitions), quite a few extra menu items, report options, etc. are added.

The purpose of the "Dirty" flag for Sites is to indicate motel rooms needing cleaned after guest check-out. When this field is enabled, a "Dirty" checkbox will be added to Site Details next to the "More Site Attributes" button.

Here are the key features of the Dirty field when it's enabled:

- A column indicating dirty sites can be added to the Rack -- see the Rack Options.
- The right-click menus will have "Mark as dirty"/"Mark as clean" options, so you don't have to go to Site Details to change it.
- You can add a Dirty column to the other Tab views (Arrivals, Departures, etc), through their Options.
- Several options for quickly setting multiple sites as clean or dirty will be available if you right-click the Site name or Dirty flag on the list-type Tab views (Arrivals, Departures, etc).
- The New Reservation dialog has a "Hide dirty sites" checkbox (above Use Preferences), so for walk-ins you can list only those sites that are clean.
- An option can be enabled to automatically set the Dirty flag when a reservation is checked out (see Program Options / Functions).
- If you use Scheduled sites (e.g. for hourly rentals or tours), you can optionally disable the automatic Dirty function for those (see Program Options / Functions). This also applies to manual functions that set multiple sites dirty at once, e.g. setting all checked-out sites dirty from the Departures tab.
- There are Access Levels for various functions which allow selecting what operator level is required to set sites dirty or clean, or set multiple sites dirty/clean, etc.
- A warning can be shown if you attempt to Check In a reservation on a site that's dirty (see Program Options / Prompts).
- Housekeeping report -- A column is added for Dirty, and an option to Hide dirty sites. A right-click menu allows setting the flags as dirty or clean for various situations (e.g. mark all pending arrivals as dirty, mark all checked out dirty, etc...)
- You can select a Global Color Scheme for the Dirty column ("header") on the Rack. Creating the color scheme for this would be up to you, but it's one of the easiest possible Color Schemes -- just create a new color scheme, select None as the default scheme, and add a rule with "Site:Site_Dirty" as the expression (no quotes). Then of course choose that new scheme in Select Global Color Schemes for the dirty column scheme.

Program Options

Overview

These settings, found under the Maintenance menu, allow customization of many aspects of the program. These settings are stored in the database so the functionality will be consistent wherever the database is used. If you're using the networking version, these options are global -- all workstations will use the same options, and changes are automatically made on every workstation.

Manager access is required to view or change these options.

P.O.S. Note: If the P.O.S. option is enabled, then there will be an additional tab on this dialog. See the P.O.S. Setup section for details on those settings.

Format Options

(Accessed through Maintenance / Program Options / Formats.)

Confirmation # Format -- This selection allows you to specify how the confirmation number is created from the reservation record ID. You can change this any time, but it will not affect reservations made previously -- it will only affect new reservations. The format is entered as text with a number of optional "tags" that will be replaced accordingly. Any text that is not recognized as a tag will be included verbatim. The default and most common format simply includes the internal reservation record ID and the workstation ID. Each tag can also specify a minimum number of digits and whether it's padded with 0's. Specifications and examples appear below. Note that upper/lower case does matter, since some tags have a different meaning depending on the case.

<u>Tag</u>	<u>Meaning</u>
<W>	Workstation ID (will always be 0 if networking not used)
<R>	Reservation Record ID, excluding workstation prefix
<WR>	Complete Reservation Record ID, with workstation ID prefix
<S>	Shift number (e.g. if Shifts are enabled)
<M>	Month (current date)
<D>	Day
<Y>	Year
<J>	Julian date (day of the year)
<H>	Hour, in 24-hour format (00 to 23)
<h>	Hour, in 12-hour format (01 to 12)
<m>	Minutes
<s>	Seconds
<a>	AM/PM (or A/P if only one digit specified like <a:1>)

Modifiers:

:digits	Minimum number of digits, e.g. <W:2>
:#digits	Maximum number of digits (truncate the left-most digits if necessary), e.g. <R:#3> To truncate the right-most digits, use :#-digits , like <Y:#-2>
:0digits	Fill any extra characters with 0's instead of spaces, put a 0 before the number of digits
:-digits	Left-justify the tag contents, include a minus sign (-) after the colon (or after #, if used). Note that 0-filling cannot be done if left-justified is also specified

Examples:

<u>Format:</u>	<u>Result:</u>	
R<W><R>	R1345	Workstation 1, record 345 (record ID actually #0100000345)
R<W><R:5>	R1 345	Same as above, 5 digits minimum (note the spaces)
R<W><R:05>	R100345	Same as above, with 0-padding specified

R<WR>	R10000345	Save as above, but the complete raw record ID is used
<Y>D<J>R<R>	2004D40R345	Feb 9th, 2004 (Julian day 40), record ID 345
<Y:#2>D<J>R<R>	04D40R345	Same as above, but 2 digit year specified

Note -- It's important that you make sure that each reservation has a unique confirmation number. For instance, don't just rely on the <R> tag if you have multiple workstations, since each workstation could potentially have the same workstation-stripped record ID (the <R> tag excludes the workstation portion of the complete record ID). Use <WR> or a combination of <W> and <R>. Potentially you could use a date and time combination, but even this has potential for duplicates if multiple workstations are present.

Receipt # format -- This is used for the Receipt # field for each transaction, and follows the same formatting rules as the Confirmation # except that the Transaction record ID is used instead of the Reservation record ID.

Date Format -- There are several date formats to choose from, which will be used most places that a date appears on a report or printed receipt. Selections include several variations of both m/d/y and d/m/y formats, with or without the weekday. Note that the computer's regional settings (for instance U.S. or Canada) will automatically affect the date-picker controls, but will not affect this setting. This setting must be changed manually.

Currency Symbol -- You can enter the currency prefix symbol here, if '\$' isn't appropriate. It can be up to 3 characters, so you can use US\$, CD\$, etc. if necessary (but be aware that these do make prices look more cluttered, especially on receipts.)

Show "Prov" and "P.Code" instead of "State" and "Zip" -- For users outside the United States, check this option to use the Province and Postal Code everywhere in the program that State and Zip code would otherwise appear.

Show discounts, payments, and other credits as negative in the "Total" column of transactions -- Check this to see a more "natural-looking" credit in the Totals column, e.g. to show a payment as a negative number (subtracting from the charges) instead of showing everything as a positive number.

Automatically format customer information to mixed-case (e.g. "smith" becomes "Smith") -- Check this option to let Campground Master auto-capitalize name and address field entries. It will generally capitalize the first letter of each word, but it knows a few common exceptions to the rule (e.g. McDonald, PO Box, etc.). The text won't be capitalized as you type, but will auto-format when it's saved.

Font sizes, thickness and custom fonts -- While the size of some parts of the program change automatically with Windows settings, like the dialogs and menus, the font used for controls in tab view and grids is defined in the program. The normal size is considered a size of 12 with a thickness of 4 (don't worry about what the numbers actually mean). You can increase the size to a higher number if needed to see the text better on your computer. A small size increase to 13 or 14 may be all that's needed. If a larger size results in a font that's too "thin", you can also try increasing the thickness to 6 or 8 to make it bolder. Note that for the default "MS Sand Serif" font, there are only 2 thicknesses, "normal" (4 and under) and "bold" (anything above 4). You can also select Custom font if you want to use a different font like Arial, which may have more variety available in the thickness (which is always a range from 1 to 9, with 4 being "normal").

There are 3 different areas that can be independently changed:

Tab view controls -- this is for the row of controls above the main grids in the Tab views, e.g. the From & To date selections, Reset/Today button, etc.

Tab view grids -- this is for the main grids in the Tab views themselves, e.g. the Rack, Arrivals, Departures, etc.

Other grids (in dialogs) -- this is for grids used inside dialogs, e.g. Find Reservation and other reports that open a new window.

Tabbed list view options (Arrivals, Departures, etc.) -- These options affect the appearance of several of the tab views -- Arrivals, Departures, On Site, Unassigned, Non-Reserved, and Payments Due.

Show a "Total" row -- This enables the extra row at the bottom of the view, showing the total number of entries (reservations, transactions, etc), plus totals for any appropriate columns such as number of adults, extra vehicles, or balance due.

Show reservations not assigned to a site even if a Site Type is selected -- Used for the views that have a Site Type selection (all except the Unassigned and Non-Reserved views). When this is not enabled, the list will show only entries for the specified site type selected in the drop-down list (unless of course All Site Types is selected). When this is enabled, it will show entries for the selected site type plus those for any with unassigned sites. Use this option if you prefer to think in terms of "it might end up as any type, so show it with all types". For example, if you want to show all Arrivals that "are" or "might be" for the selected site type.

Show grid lines by default (must restart to take effect) -- This is the default, so all grid views show the grid lines. If you prefer not to see lines in the grids for a cleaner look, then you can turn this option off. It will not immediately turn grid lines on or off, but will take effect the next time the program is started. You can manually turn off the grid lines on each grid (except the Rack view) using the **Grid Lines** option on the right-click context menu.

Function Options

(Accessed through [Maintenance](#) / [Program Options](#) / [Functions](#).)

Customer toolbar icon invokes "Find Customer" instead of "Add New Customer" -- If you find that you often use the Find function after clicking the toolbar to add a new customer (a good practice to avoid duplicates), you can set this option so the Find Customer dialog opens immediately. If the customer is not found, clicking "Cancel / Add New" on the Find dialog will take you back to Add New Customer so it can be added.

"Find Customer" defaults to showing all customers when not starting with a partial name -- If your customer database is small, you may decide that it's easier to just scroll through the complete list of customers rather than having to enter a name first. You can enable this option so that the Find Customer list starts with all customers instead of being blank -- but be aware that this could be slow if your database is large. Only the most important fields are shown initially to make it faster (name, city, state, and notes), but after making any filter changes the fields shown will change according to the filter type. For instance if you do want to see all of the fields for all customers then you can check and then uncheck the Filter By box to refresh the list.

Cash-register toolbar icon invokes "Unbound Transactions" instead of general Transactions -- This is enabled by default so that the cash register icon is just used for counter sales, like a point-of-sale system. If you don't do counter sales, then disable this option. You can then either have it go directly to Reservation Transactions (see below), or to the generic [Add a New Transaction](#) dialog (which lets you first search for a customer or reservation).

P.O.S. Note: If the P.O.S. option is enabled, then this setting will show "Point of Sale" instead of "Unbound Transactions". The Point of Sale dialog will be used instead of Unbound Transactions.

Cash-register toolbar icon invokes "Reservation Transactions" -- If you often need to enter transactions for reservations, enable this option so the cash register first opens the Find Reservation dialog, and then opens the New Transaction dialog for the selected reservation. The "Unbound Transaction" option above must be disabled before this option can be selected.

Include a "Print Window Tag" button on the Transactions dialog -- This option adds a button to Transactions so that a window tag can be printed in a single click, rather than selecting it from the drop-down list each time.

Show a "Change Due" message when printing new receipts and change is due -- Enable this to show a pop-up message showing how much change is due. This is shown immediately after the receipt is printed, so you can be making change while the receipt prints. Note that it will only be shown if "new" payment or deposit transactions are made with an amount tendered entered.

Round "Change Due" to nearest 5 cents (when an amount for cash Tendered is entered) -- For countries like Canada where the penny is being phased out, you can select this option to show the proper rounded-to-the-nearest-nickel amount of change to give when a cash payment is entered and a "Tendered" amount is specified. The rounded amount will also show on receipts, however this does not affect the recorded total for the transaction or the amount of payment received for the transaction. Any discrepancies due to rounding will be minimal in the long run, and should be handled the same way as any other minor cash drawer imbalance.

Automatically set Paid-Thru date when a reservation is paid in full (skip the warning prompt) -- This saves the step of setting paid-through whenever a reservation is paid in full, on the Transactions dialog. If this option is not selected, a warning prompt will be shown if it appears that the paid-thru date should be set, unless the warning prompt is disabled in the Prompts option.

Automatically Guarantee a reservation when a deposit is made (or transferred in) -- With this option set, a reservation will be changed from Pending (or Confirmed) to Guaranteed status automatically if a Deposit is added to a reservation, or if a deposit is transferred into the reservation. This simply saves a couple steps, so you can go straight to the Transactions and enter the deposit instead of using the Guarantee function or checking the Guaranteed box on the Reservation Details.

Automatically set the site as 'Dirty' when a reservation is checked out -- Only available if the Site Dirty field is enabled, this will set the site "Dirty" flag after every check-out.

Do not set Scheduled sites as 'Dirty' -- If you use Scheduled sites (e.g. for hourly rentals or tours), setting this option will disable the automatic Dirty-on-checkout function for those. This also applies to manual functions that set multiple sites dirty at once, e.g. setting all checked-out sites dirty from the Departures tab.

Don't allow reservations to be made without a site assigned -- If you don't use the unassigned reservations functionality at all, then select this option to make sure no reservations are made without a site assignment. (If this option is not selected, there is still the option in the Prompts Options section to show a warning if no site is assigned.)

Inquiry reservations with a site show on the Rack and block others -- This allows you to "pencil-in" reservations on a particular site by making it an Inquiry, effectively reserving that site and making it unavailable for other reservations, but not making it an "active" reservation (it won't show on Arrivals, On Site, etc. until you elevate its status to Pending or higher). Without this option selected, Inquiry reservations won't show on the Rack or Map even if they have a site assigned, and won't block other reservations.

"Show Available Only" shows open & available sites plus... -- The options in this box allow you to fine-tune what is defined as "available" for the purpose of the "Available Only" check box on the Rack View, as described below. Note however that this doesn't change whether a reservation can be made on the site immediately, since a reservation on the site will still block new reservations. This allows you to consider the possibility of replacing a low-priority reservation with a higher priority reservation.

Off-season and special dates unavailable -- Set this option if you want to consider sites available even if the site's "season dates" or "special unavailable dates" indicate that it shouldn't be available. This might be useful if you have sites that aren't normally used off-season, but you would use if necessary for an extra-large crowd.

Blocked reservation dates -- Set this option to include sites even if the dates are blocked by an existing reservation. Since the purpose of reservation "blocking" is to indicate that the customer might stay longer than his initial reservation but isn't sure, this would let you know that a site might be available if the customer does decide to leave. If that's the only "available" site for a new reservation, you could then ask the current customer to make a decision so you can book the new customer if possible.

Inquiry Reservations -- Set this option to include sites with Inquiry reservations, assuming the other option (above) is set to show Inquiries on the Rack. If you're using the option above to include inquiries as a pencil-in feature, this will show that a site could be available depending on the outcome of the inquiry/penciled-in reservation.

Un-Confirmed reservations -- Set this option to show sites with pending reservations as still available unless the reservation is "Confirmed". This is useful if you have a strict confirmation policy, so that you can cancel an unconfirmed reservation if a new customer needs the site and the confirmation is overdue.

Un-Guaranteed reservations -- Similar to Un-Confirmed above, set this to show sites as still being available as long as the customer has not "Guaranteed" a reservation (for instance with a credit card).

Double-click actions for tab views -- These settings allow changing what happens when you double-click on a Reservation or a Site. The default action is to show Reservation Quick-Info and Site Quick-Info windows, respectively. You can change this to do another common function that you would normally access from the right-click menu, or you can enter a custom Expression (e.g. to run a custom script), allowing infinite flexibility. When "Execute Expression" is selected, click on the text box to the right of the drop-down list to edit the expression.

Note that these will be the *defaults* for all tabs -- however the actions selected here can be overridden for each tab by selecting a double-click action through Advanced Customizations / Tab Views. This allows you to specify a different double-click action for each of the Tab Views.

On a Reservation -- Select an action for double-clicking on Reservations, e.g. the customer's name/label on the Rack, an occupied site on the Map, or any cell related to a Reservation on other tab views (except the Site name or Type). For the Transactions tab view, this includes any transaction field that is linked to a Reservation.

On a Site -- Select an action for double-clicking on a Site, e.g. the Site's Abbreviation or Type on the Rack, or the site's Name or Type on one of the other list-type tab views. On the Rack and Map, double-clicking on an available site/date will always open "New Reservation", however the action selected here will be used if the site is Unavailable for the date. On the Transaction tab in detail view, this action will be used if the transaction does not belong to a Reservation (which of course means it has no Site either, so if showing Site quick-info that will be empty as well).

Prompt Options

(Accessed through [Maintenance](#) / [Program Options](#) / [Prompts](#).)

Warn when no site is selected for a new reservation -- When this is set, the user will be warned when making a New Reservation and a site has not been selected. If you commonly make reservations without assigning a site until they arrive, then you may want to turn off this prompt. Note that this option is irrelevant if the unassigned reservations are not allowed (see the Functions Options section).

Warn when a reservation is made on an "unavailable" date for a site -- Normally, the program will show a warning prompt if a reservation is made that covers a date that is marked as unavailable for the site. You can disable this warning if your reservations commonly cover unavailable dates. One example of this would be making a full month reservation for a site that's normally only available weekends, to avoid making 4 separate weekend reservations.

Warn when checking in on a site where the previous reservation is not checked out -- If you need to be strict about using the check-out process in Campground Master, for instance in a motel type of situation, then select this option. When a Check In is attempted, it will check the previous reservation on the same site (no matter how far back it was supposed to be checked out). If it hasn't been checked out yet, then a warning will be shown along with the option to abort the check-in. If desired, you can also set an Access Level for which checking out the previous reservation is required, in which case it will show an error instead of just a warning, and will not allow the check-in.

Warn when checking in on a site marked as 'Dirty' -- Only available if the Site Dirty field is enabled, this will pop up a warning if a check-in is attempted on a site with the "Dirty" flag still set.

Warn when making full/partial payment but Paid-Thru not set (various options) -- Unless the "Automatically set paid-thru" option is set in the Functions options, you will normally get a warning when a payment is made that doesn't result in a zero balance, if the Reservation's Paid-Through date is not set to the Last Night (or Auto-Charged-thru date). You can turn off that warning for by disabling one or more of these options, for whether it's done for full or partial payments, monthly or non-monthly reservations (based on the Reservation Type), and for Payment or Deposit transactions -- each combination can be set separately.

Show a Reminder if the Customer has a usable credit balance, when making a new Reservation (also an option to show when checking in) -- Select this if you want a reminder to be shown if the customer has a credit balance that could be transferred to the reservation (e.g. a Deposit, Payment Transfer, etc that exists on the Customer record, not part of some other reservation, that was put there to hold a customer credit for a future reservation).

... and offer to perform the transfer immediately, if possible and appropriate -- Select this if you also want to be able open the Transfer function when the reminder is shown that a credit is available to transfer. "Possible and appropriate" means that there are times when it won't be able to, for instance if the operator doesn't have access to the transfer function, or if the reservation will not have charges yet so that a Payment transfer would result in Uncategorized receipts.

Ask for confirmations for simple reservation changes and actions -- If you're sure-fingered enough to not require prompts for every right-click action on the Rack, etc., then you can turn off these prompts to save time.

Ask if staying the same number of nights when the start date is changed on the Rack -- This prompt is enabled by default, and will appear any time the start date (First Night) is changed as a result of an action on the Rack. This will apply to changing the start date directly with the [Advance Next Reservation](#) and [This is New Start Date](#) functions, but can also be as a result of a [Check In](#) function if the reservation does not already start today. The prompt will ask if the customer is still staying the same number of nights, and if answered "Yes", it adjusts the ending reservation date automatically. If this is usually the case, it will save the added step of adjusting the end date manually. If this is not often the case, you may choose to disable this prompt.

Transactions Options

(Accessed through [Maintenance](#) / [Program Options](#) / [Transactions](#).)

Open a Transaction dialog when... -- This selection allows you to specify the circumstances in which you want the New Transactions dialog to automatically appear. Your choices here will probably depend on whether you enter charges before a reservation is checked in, and whether you prefer to review charges any time a change is made. Most of these options are self-explanatory, so they won't be detailed here.

One option of special mention is the **... and automatically go to "Select Rates"** option for checking in. When enabled, this will typically save one additional step when checking in reservations by immediately prompting for the rate selection. If you don't normally use Select Rates when checking in a reservation (for instance if you add the charges ahead of time), then you may disable this option.

Prompt for details when entering transactions (instead of entering them in the grid) -- This option enables a whole set of transaction-entry dialogs. The "old" method was to enter transaction details (qty, description, amount, etc.) directly in the transaction grid. These new entry dialogs are more user-friendly and allow entry of more details. However they do typically require an extra click or key press. If you just prefer the old way of entering the details in the grid, you can disable these new dialogs.

Include a Pay Method selection list on Transactions dialog -- Enable this to include a drop-down payment method selection on Transactions (this is redundant if the Prompt for Details option above is selected.)

Post-date Deposit Applied transactions to check-in date -- With this option enabled, it will make sure that Deposits are not "applied" to the reservation until check-in date, but post-dating any Deposit Applied transactions. This has a major affect on when "income" is reported -- see the section on Recommended Transaction and Reporting Procedures for important details.

Also keep off of Shift report until Check-in (blank Shift #) -- As with the above option, this affects Shift Reporting if you use that functionality .

Post-date reservation charges to the check-in date -- This will post-date all Charge transactions (along with Taxes, Discounts, and Credits) to the check-in date. As with post-dating the Deposit Applied (above), this further affects how income is reported.

Save the transactions done in Quote/Confirmation -- If you have the post-dating options enabled, then you can further streamline operations by saving the transactions in Quote/Confirmation (which are otherwise temporary/discarded after the confirmation is done). This also allows you to enter Deposits, etc. from Quote/Confirmation since they will be saved.

Allow transaction categories to be selected for payments -- Enabling this option allows payments to be assigned to specific categories. This is useful if you use the Receipts by Category report and need to manually allocate categories to overcome interpolation issues (for instance when payments are made in advance, or if monthly reservations are not paid in full each month). This adds a category list to the Enter Payment (or Enter Refund) dialog, and also allows editing allocations later.

Warn that transactions should go on the master -- For linked reservations, transactions should almost always be entered on the "linked transaction master" reservation. When this option is not checked, then they will always be placed there automatically. If you check this option, you will be able to put transactions on other linked reservations, but it will warn you each time. Also note that if this option is not checked, then the "handle synchronized reservations separately" options in Monthly Billing and the Meter List reports will not be available.

Save transactions immediately when a payment is entered -- This helps prevent "missing" payments caused by accidentally clicking the Cancel button.

Save transactions immediately when a receipt is printed -- If you're concerned with accidentally clicking Cancel on the Transactions dialog after entering transactions and printing a receipt, select this option. Printing a receipt will force all pending transactions to be saved, so Cancel will not delete them.

Automatically print a receipt as soon as a payment is entered -- This simply saves a mouse click to speed up operations, presuming that you always want a receipt printed. As soon as a Payment is entered (not a Deposit), a receipt will be printed (using the default receipt format selected in Printing Options / Receipts). Note that this also affects Customer transactions and Unbound transactions, not just Reservations.

...only if it's a credit card payment -- Select this along with the option above if you only need a receipt printed for credit card sales.

Receipt format -- This will initially default to the "Reservation Receipt default format" selection chosen in File / Printing Options. You can select a different type here to be used for auto-printed receipts. See Receipt Types in the *Working with Transactions* section for details on the different types.

Use the default in Printing Options (on each WS) -- Select this option if you prefer to use the default receipt format selected under Printing Options / Reservations when auto-printing (this is necessary for example if you need to use different receipt formats on different networked workstations)

Note that only one copy of each receipt will be automatically printed -- the "Copies" setting in the Printing Options is ignored.

You also have the typical options for what transactions to include, either All transactions or just some, like for printing receipts from the Transactions dialog.

Reservation Options

(Accessed through Maintenance / Program Options / Reservations.)

Quick-select preferences/add-ons -- You can select up to 5 "Attribute" fields to show as checkboxes on the New Reservation dialog. This enables quick selection of add-ons, particularly useful for features that have added charges (Add-On rates). If less than 5 are selected, you should use the top-most entries, rather than leaving blanks in between selections.

Reservation Default Values -- This button will open a separate window to set various default values when making a reservation (and also when canceling a reservation).

Advanced Deposit Amount -- These settings are used with the Deposit Definitions to allow the calculated amount of deposit required to automatically appear when entering a Deposit payment.

Entry/calculation method -- Select whether you want "Manual entry" (no automatic functionality), "Auto-set from definitions" (use deposit definitions to calculate and fill in the amount immediately), or "Add 'Auto-set' button" (don't calculate the value initially but have a button that will calculate it when desired).

If no deposit applies -- If it tries to auto-calculate the deposit but can't find a suitable definition for the reservation, choose whether to just leave the amount blank or to also show a warning that no definition was found.

Automatically Find Customer after Last Name is entered on New Reservations -- This enables a quick-find function when entering the customer name when making New Reservations. A small version of the Find Customer dialog will open automatically after the Last Name is entered, allowing quick selection of a previous customer. Without this enabled, the Find Customer button must be used to find existing customers.

Duplicate Customer Checking -- This button opens a separate dialog for setting the criteria used in checking for duplicate customers when entering a new reservation.

Show Quick-Pick site list on the New Reservations dialog -- By default, a Quick-Pick site list appears on the New Reservation dialog so that a site can be selected from a list instead of from the mini-rack view. However this can be cumbersome if your park has many sites, so you may choose to disable this feature and take the list off of the dialog.

Start New Reservations with "Show Available" checked -- This option only affects the "New Reservation" dialog. When set, the "Show Available" option will default to being checked (on) by default in the New Reservation dialog, so only the available sites will be shown.

"Show Available" also affects Quick-Pick selections -- With this enabled, the Quick-Pick list on the New Reservation dialog (and Assign Site, etc) will only show the sites "available", e.g. on the dates selected and matching other criteria, if the "Show Available" option is selected. Therefore it will generally show the same sites as the grid. If you prefer that the Quick-Pick list show sites even if they're not currently available, uncheck this option. If you have a lot of sites, this option can affect how quickly the screen is refreshed when changing a date, etc.

Start New Reservations with "Use Preferences" checked -- This option only affects the "New Reservation" dialog. When set, the "Use Preferences" option will default to being checked (on) by default in the New Reservation dialog, so only the sites with the specified preferences will be shown. Uncheck this if you want to ignore preferences at first.

Start Assign/Change Site with existing Preferences -- This is similar to the above option, but applies when changing sites assigned to a reservation, or adding linked reservations (Sub-member, Synced, or Non-synced). When set, the "Use Preferences" option will default to being checked (on) by default, so only the sites with the specified preferences will be shown. In addition, if a Site Type or Site Class is selected in the reservation's preferences, then that will be selected. Uncheck this if you want to ignore preferences and site type/class and show all sites instead.

Use date selections from the Rack (when double-clicking), if 'Available Only' is checked -- This option is enabled by default, so you can use the main Rack view to check site availability for selected dates and choose a site. If this sometimes results in the wrong assumption about reservation dates, it can be disabled. For instance, if you like to use the Rack to select sites that will be available for several days longer than the reservation, then this could result in the wrong dates being assumed for the new reservation.

Enable automatic multiple-site selection -- When this is enabled, a "Qty" field will be added to the New Reservation dialog. This can be used to have it automatically select and add a number of sites, instead of selecting each one individually.

Automatically copy any existing Customer Notes to New Reservations Notes -- If you typically have notes in Customer Details that you want to see when making a new reservation (e.g. warnings or special circumstances), set this option so the Customer notes will always show up on New Reservation and will also stay with the Reservation Details. With this option unchecked, the Reservation Notes will always be blank to start with.

Automatically copy New Reservation Notes to Customer Notes -- Set this if you want any new or changed Notes entered on the New Reservation dialog to be copied back to the Customer Details (e.g. so they show up again next time you make a reservation for this customer). However, if there are existing Customer Notes and you modify the Notes in the New Reservation, then the Customer notes will not be overwritten with the new Reservation notes.

Keep the Rack and Map views on the same date when switching between them -- When this is enabled, the Rack and Map views will be kept in sync as far as the From and To dates selected. If this option is not enabled, then changing the date on one view will not change dates in the other view.

Remove checked-out reservations from the Rack (make available for extra check-in same day) -- When this is selected, checked-out reservations are removed from the Rack (and treated as an available site) instead of showing in a dark grey color. This is not generally recommended (it's often handy to see what sites have been recently vacated and who was there), but you may need to set this option if you commonly have

people check out the same day they arrive and you want to make that site available for someone else arriving later that day.

Allow Guest reservations to be checked in before the host (and checked out after the host) -- Normally you would want the person with the main reservation, or host, to arrive before any of his guests (Guest reservations on the same site). Therefore this option is not enabled by default. However if you handle Guest reservations in such a way that the guests may arrive before the host (and likewise if the guests may leave after the host), then enable this option so they can be checked in or out in any order. Note that this refers only to the *time of day* they arrive or leave -- they can never arrive on a *day* before the host reservation starts or leave on a *day* after the host reservation ends.

Show a 'Guarantee Reservation' information dialog for entering details when Guaranteeing a reservation -- When this is enabled, a Guarantee Reservation dialog opens whenever you do a Guarantee (e.g. from New Reservations, Reservation Details, or the right-click menu), which allows entry of notes, credit card information (depending on the next setting below), and sometimes has buttons for entering a deposit, etc.

Allow credit card information to be entered on Guarantee Info (for Customers and Reservations) -- When this is enabled, the Guarantee information dialog will have entry fields for credit card information. You can disable this if you don't plan to keep credit card information for guarantees. **IMPORTANT:** Do NOT disable this if you're going to enter card numbers, since you must use the special credit card entry fields to store card securely!

Reservation Default Values

(Accessed through [Maintenance / Program Options / Reservations](#), click the "Reservation Default Values" button.)

Default ETA -- You can select one of the selections from the Estimated Arrival Times pick-list as the default for new reservations, or you can select the blank entry if you want it blank by default. If you have the appropriate operator access, there will also be a button to the right to [Edit ETA pick list](#). You can click on that to directly jump to the Pick List editing function for the ETA list, without leaving the Reservation Defaults dialog.

Default type -- If most of your reservations will be a type other than Normal, you can set the default reservation type here.

Default starting date -- This affects the Rack, Map, and New Reservations. Normally you would leave this as some past date, and make sure the next option, to ignore the default date, is checked. However if you're making reservations for the next season, then you can set this to your season starting date to save time scrolling the Rack each time.

Ignore default start date once it's in the past -- Normally you would leave this checked, however if you are trying to work on past reservations then you can set the default start date to a past date and uncheck this, so the rack starts in the past.

Default # days for new reservations -- If your typical reservation is for a specific number of days, for instance if you primarily rent 3-day weekend packages, then you can change this value. Any reservations started fresh, e.g. by double-clicking the Rack or Map, or from the New Reservation icon or menu function, will default to this number of days (nights). Note that this will be ignored in the special case of setting a date range on the Rack with Available only checked (see the option below).

Default cancellation type -- Select the default "Type" of cancellation whenever a reservation is canceled. You can leave this blank to force manual selection. This is also subject to an Access Level setting, so you can determine which level of operators the default will be used for (else they will need to select it manually each time). Note that this is a fixed list, it cannot be changed.

Default Cancel Reasons for each Cancel Type -- For each of the 5 Cancel Types, you can choose the default "Reason" for the cancellation that will be selected for each Type. This will just be a default selection --

the operator can always change it when doing the cancellation. This is also subject to an Access Level setting, so you can determine which level of operators the default will be used for. Note that this list comes from the Pick List for Cancel Reasons, which can be modified. If you have the appropriate operator access, there will also be a button at the bottom to [Edit the Cancel Reasons pick list](#). You can click on that to directly jump to the Pick List editing function for the Cancel Reasons, without leaving the Reservation Defaults dialog.

Duplicate Customer Checking

(Accessed through [Maintenance](#) / [Program Options](#) / [Reservations](#), "Duplicate Customer Checking" button.)

Here you can enable the automatic duplicate checking and/or the manual duplicate checking button in New Reservations, as well as select which fields are to be checked for duplicate information.

Note that when selecting multiple fields to check, only one of them has to match in order for it to be shown as a possible duplicate. For instance if you select address and phone number, they don't have to both be the same -- it will show as a duplicate if the address matches **or** a phone number matches.

Here are details of how it checks for duplicate information for each comparison option:

Address -- The Zip/Postal code and the Address line 1 and 2 fields are compared, ignoring any punctuation or other characters besides letters and numbers. The comparison is not case-sensitive, and if both address lines and are filled in it will match in either order. However it does need to be entered mostly the same to match -- "123 Jones Lane" will not match "123 Jones Ln." because the word Lane is not spelled out in both cases. However "12-A Jones Ln" and "12a Jones Ln." will match. So if this comparison is used, it's a good idea to get in the habit of always spelling out each word or always using the common abbreviations.

Phone number -- Phone numbers are compared using only the numbers, and ignoring any leading 0's or 1's. Thus "1-888-555-1212" will match "(888) 555-1212". It checks all 3 phone number fields against each other (in any order), and only one needs to match.

E-mail address -- The E-mail addresses are compared without case sensitivity, but otherwise must be an exact match.

Driver's license -- All non-digits are ignored, so only the numeric portion is compared.

Vehicle licenses -- Only letters and numbers are compared, and it's not case-sensitive. So for instance "TX/ABC123" will match "TX - abc 123".

Discount membership ID's -- Only letters and numbers are compared, and it's not case-sensitive. All 3 discount fields are checked, and only one of the 3 needs to match any other one.

Other fields -- Up to 3 other fields can be checked, such as user-defined fields or any other customer fields. Only letters and numbers are compared, and it's not case-sensitive. Remember, though, that these checks are independent of others -- so for instance if you select the Country field to compare, it will list **all** other customers with the same country as possible duplicates even if no other information matches.

Note: After saving changes here, be sure to click "[OK](#)" on the Program Options dialog -- if you click "[Cancel](#)" there, these changes will be lost also.

Auto-Rates Options

(Accessed through [Maintenance](#) / [Program Options](#) / [Auto-Rates](#).)

Enable Auto-Rates functions (calculation buttons) on Transactions and Select Rates dialogs -- This is the primary enabler of auto-rates, since it enables the auto-rate calculation buttons (which are used for manually adding the auto-calculated rate charges). However, if the "Automatically..." functions are enabled (below), the rates will be added automatically even if these buttons for manual adding the charges are disabled.

Auto-calculate when the "Check Rates" function is used -- When selected, auto-rates will be used to automatically calculate the temporary charges shown in the "Check Rates" function.

Auto-calculate when opening the "Quote/Confirmation" function -- When selected, auto-rates will be used to automatically calculate the charges when Quote-Confirmation. Note that if you're configured so transactions done in Quote-Confirmation are saved (as post-dated), these will be saved unless you Cancel the Quote/Confirmation dialog. Otherwise, the auto-calculated charges won't actually be saved. See Transactions Options for more details.

Calculate for longer periods to find "best" rate -- When selected, this will not only calculate the charges for the reservation's actual days, but will also calculate for additional days, one at a time, up to the maximum (below). It will then select the number of days that produced the lowest rate. This is used to give the customer a "better" rate, for instance if your weekly rate is better than the normal rate for 6 days.

Maximum extra days to check -- If you enable calculation for longer periods, this defines how many extra days to check. Don't set the number of days any longer than necessary, since it can take time to check each possible length of stay for the best rate. For instance, if your monthly rate is equivalent to 3 weeks and 2 days (23 days), then only check 8 extra days to cover a 31-day month. If you don't have monthly rates, then this probably only needs to be set to 2 extra days (e.g. if the weekly rate is cheaper than the 5-day rate).

When recalculating auto-charges... -- This gives you 3 different options for how charge transactions are handled when auto-calculation is done after auto-rates are already present (whether it's done manually with the buttons, or as a result of automatic re-calculations). Note that none of these will affect manual charges or payments added -- they only affect auto-charges.

Credit & add only charges that have changed, as needed (recommended) -- This will check each of the "new" charges against the previously added auto-charges, and will only add the necessary transactions to reflect the new charges. It will leave any previous auto-rates intact. This may result in both positive and negative entries to make the adjustments, but won't duplicate entries. For instance, if a charge for 4 days is present and a new day is added, a charge for 1 day will be added. If the days aren't changed but an additional vehicle is added, then only the charge for the additional vehicle will be added.

Add credits (negative charges) for all old auto-charges and add all new charges -- This will leave the original auto-charges alone, but will add negative charges for every previous auto-charge, then add the complete set of new charges. This results in more transactions, and can make the receipts either more or less confusing depending on the situation.

Remove all old auto-charges and add new ones (will cause daily balances to change!) -- This results in the "cleanest" receipts, but cannot be done if you depend on daily transaction balancing. It also does not leave a trail of original charges and changes -- it simply removes all old auto-charges and starts over.

Automatically add auto-charges when a reservation is... (Created, Checked In, or Checked Out) -- If this option is selected, charges will be added automatically as soon as the reservation is created or when it's checked in or out, as desired. The normal recommended option is to add them when the reservation is "Checked in", so the charges aren't considered income on reports until after they check in. In this case they will be added before the transaction dialog is opened during the check-in process, so the amount due will be instantly presented. However, if you are using post-dated Charge transactions (as enabled through Program Options / Transactions), then it may be best to set this to "Created", since the charges will be post-dated anyway and thus won't show on reports until the reservation is checked in.

Also add auto-charges to day passes when they are created -- Since day pass reservations are never checked in, you must enable this option to have charges added to day pass reservations immediately. However if you select the "Created" option above, this is not necessary.

Automatically recalculate charges whenever reservation details are changed, as appropriate -- This option will help prevent charges from being forgotten if reservation changes are made (e.g. adding extra people, changing dates, adding options, etc.), but it can also be a little dangerous and can result in a lot of charges being added and deleted back and forth if reservations are tinkered with. It's recommended to try enabling this option to see how it works for you, and disable it if it becomes an annoyance. If this option is disabled, you must remember to go to Transactions and click the Auto-calculate button whenever changes are made.

Assume no auto-charges apply for canceled reservations -- If you add auto-charges when the reservation is created, and you give refunds for canceled reservations (at least for the rent), then select this option. Any auto-charges present when a reservation is canceled will be undone when it auto-calculates. This avoids having to manually remove or credit all of the auto-charges. You can still add a cancellation fee or other manual charges if needed.

Zip Codes

(Accessed through [Maintenance](#) / [Program Options](#) / [Zip Codes](#).)

The automatic zip-code lookup functionality in Campground Master helps speed customer data input. This will be enabled for both U.S. and Canada zip codes. If your customers are rarely from these countries, you can disable one or both of the lookup functions.

Enable Zip-code lookup for the U.S. -- You can disable this if needed, so it won't attempt to do a lookup when an zip code is entered.

Fill in the "Country" with -- If you want the country to be filled in for U.S. addresses, enter the desired text here (e.g. "United States" or "US").

Enable Postal-code lookup for Canada -- You can disable this if needed, so it won't attempt to do a lookup when a Canadian postal code is entered.

Fill in the "Country" with -- If you want the country to be filled in for Canadian addresses, enter the desired text here.

Use UPPER case city names -- Check this box if you want the city names to be entered as all upper case letters.

Data loaded -- This simply shows the number of zip/postal codes it knows, to confirm that the correct code data has been loaded. Note that this data comes from the file "zipcodes.dat", which must be located in the same folder as the Campground Master executable file. The data is loaded into memory when the program is started. If you do not want any automatic lookup functionality, this file can be deleted to minimize the amount of RAM used.

Zip code data last updated - This shows the date that the zip code data was updated (usually the date of the last major software version installed). If this is more than a year old, you should consider installing a new software update to get the latest zip code information.

Monthlies Options

(Accessed through [Maintenance](#) / [Program Options](#) / [Monthlies](#).)

These options make it easy to automatically set the length of monthly reservations, and the amount initially charged. Most settings only affect reservations with the Monthly reservation type.

For "Monthly" Reservations, 1 "month" means --- this setting lets you determine whether a "month" is really a calendar month or whether it's a fixed number of days. For instance if you want a monthly reservation to always be due on the same day of the month (either a common day for everyone, or based on their starting date), use the [One calendar month](#) setting. If you prefer to use a fixed number of days as a "month", set it to [A specific number of days](#), and enter the number of days preferred, like 30. Note that this can be anything you want, in fact it could be set to 7 days if you don't really have "monthly" reservations but want the typical Monthly functions to apply to weekly reservations (e.g. auto-rates, Monthly billing, etc).

Note that if this is set to a specific number of days, it also changes the [+1M](#) buttons on the Reservation Details and New Reservation dialog to [+30](#), for instance. Likewise, the [Extend 1 month](#) button on Monthly Billing will change to [Extend 30 days](#) (or whatever your number of days is).

There are 3 different settings allowing automatic date setting, based on the start date of the reservation, to a specified number of months, or to the end the month any number of months away, or the end of a year. These automatic settings can also be disabled by selecting the "none" options.

Automatically extend reservation -- This setting determines the automatic Last Night of a new reservation when the Monthly reservation type is selected on the New Reservation dialog, if (and only if) the reservation's Last Night has not yet been selected manually or by entering a number of nights. For instance to make all monthly reservations for at least 5 months, select "by exactly one month", and enter 4 in "and then add another ___ months".

Also Block the site for the reservation -- This works similar to the setting above, but instead of setting the Last Night, it sets the Block date. For instance, you may want to make the actual reservation for only a few months, but keep the site blocked for several years.

Limit the initial number of days charged to -- This is used when selecting rates for a monthly reservation. This is normally only the initial charges, since the Monthly Billing will likely be used for subsequent months. Only a few options are available here -- charge for exactly one month, to the end of the month, or to the end of next month. This setting will depend on whether you force billings on the first of the month, and whether you require at least a month's rent up front.

The combination of these settings depends partially on your monthly billing procedures (exact-month or end-of-month), but in general there are a couple different recommended ways of doing monthly reservations.

One way is to only "reserve" the site for one month at a time, but block it initially for an extended period (this can be several years if you like, or just a few months, depending on the typical length of stay). Then when monthly billing is done, extend each reservation by an additional month (this is a one-click function on the Monthly Billing dialog). This may work best if your monthlies are typically short-term (less than a year), and are billed on their month-anniversary date instead of the first day of the month.

Another good way is to go ahead and make the reservation extend out to the end of next year. Then at the end of this year, when you do the monthly billing go ahead and extend them all another year (keeping the site reserved for at least 1 year in advance). This works best for billing on the 1st of each month (presumably the first partial month is pro-rated), where your tenants are likely to stay at least a year at a time.

Database Options

(Accessed through Maintenance / Program Options / Database. This portion of the Program Options dialog will only be available if you're logged in with an Administrator access level.)

Current database path -- This shows the complete disk and directory path of the currently open database. The database name itself isn't shown, but you can see the database name in the program's caption bar. This field is not editable -- to open a different database, use the File / Open function from the main menu.

Auto-open database file and path -- This shows the complete path and the file name of the default database, which opens automatically every time the program starts (unless another file is specified in the command line of the shortcut icon, as in the case of the Demo icons). This is generally set when the New Database function is done to start a new one, or the first time a File / Save a Copy As is done with a name other than "demo". The only way to change the auto-open database is to open the desired database and click the "Change" button below this field.

Change the Auto-open database to the Current database -- This button will change the setting above, so the currently open database will be used as the default from now on. This should only be done if you're sure that the current database is what you want all future changes to go to.

Automatically save the database after each action -- This option is enabled by default, so that the database is saved to the computer's hard disk after every action -- for instance, after every new reservation, check-in, transaction, or anything else that changes the database. Note that it's saved after every main dialog is closed, not while working in the dialog. You can also set it to wait for a certain number of seconds of inactivity (see below). It's preferred to leave this function enabled and set to 0 seconds so it saves immediately after every change, to minimize the chance of data loss in the case of a malfunction or power loss. However you may need to turn it off or set it to delay a number of seconds if you see it taking a noticeable amount of time to save the database, due to a slow computer or large database (watch the Status Bar to see how long it shows "Saving database...") You may also wish to disable this option if you are experimenting or making changes that you're not sure you want to keep, so you could reload the previous database without saving the new changes.

...but wait for _____ seconds if inactivity -- This can be set for the auto-save function above, so that it waits until the computer is idle (no mouse or keyboard input) for a number of seconds before it saves the database. See the comments for the "Automatically save" setting above. Also note that this delay can be overridden by the minimum delay set in the Network Setup, if you have the Networking option.

Include Map images and Form bitmap files -- With this option enabled, any map image files used (through Maps Setup) and any bitmap files used on custom Forms are included in all compressed backups, and will be automatically restored if a Restore is done to an existing database. (However if the "current" database location is not known, as when restoring to an <UNTITLED> database, then the image files are not restored because the correct location is not known.) Note that this also includes the files in the "Request a full database refresh" networking function, so this can be used to copy or update Maps and Form bitmaps from the master to the client computers.

Secondary auto-backup path -- Normally an auto-backup is saved each day to the same folder as the database. As mentioned elsewhere, this is mainly for quick auto-recovery and not a substitute for a good backup plan. Here you can select a path where it will make an additional auto-backup, which could be a cloud service, external hard drive, or shared network drive for instance. Note that it does *not* auto-delete older backups from the secondary location like it does the main location. The user must manage clean-up themselves if needed. Also note that this setting is computer-specific (you can set it on one or multiple workstations, and you must set it up again if you change computers).

Remind me to back up the database every ... days -- When the program is closed, it will remind you to back up the database if you haven't done a manual backup in so many days. By default this is 3, and we recommend no longer than that. But if you have an automated backup system in place for the entire system, you may decide to turn this reminder off (set it to 0) or make it longer as needed. Note that this is 24-hour

periods, so if you set it to 1 day then it will remind you every day when you shut down, unless it has been less than 24 hours since the previous backup.

Automatically delete logs after ... days (0 to 999 days) -- Depending on your disk space, you may want to have the program automatically delete the oldest history logs automatically. This also applies to the automatic database backup files that are created each day. The size of the log files depends on the amount of activity each day, but generally a 30-day history is only a few megabytes. You should keep at least 7 days of logs available in case a restore is needed. You can also set this value to 0 to completely disable log deletion -- however, the automatic database backups will never be deleted in less than 7 days unless the hard disk is getting full.

Delete all old log files (except today) and **Delete ALL log files** -- These should only be done if directed by technical support, and only if you're sure that a verified working backup is available. These functions will delete all logs except the current day, and is typically only used to solve problems with network synchronization due to excessive log size (e.g. when a workstation has been offline for a long period of time). Without the log files, networking cannot automatically synchronize individual changes made on each workstation, so the server may need to send the entire database to each client.

Printing Options

Overview

These settings, found both under the File menu and under the Maintenance menu, allow customization of the way things print. Note that these settings are workstation-specific -- that is, if you are using multiple workstations on the network, changing the printer settings on one workstation will not affect the printer settings on other workstations.

Printer Setup -- Before printing receipts, you should go to File / Printer Setup to configure the appropriate printer (especially if using a 3" roll paper receipt printer). See the chapter "*Setting up your Campground Database*" for details.

P.O.S. Note: If the P.O.S. option is enabled, then there will be additional tabs on this dialog. See the P.O.S. Setup section for details on those settings.

Reports Settings

(Accessed through Maintenance / Printing Options / Reports, or File / Printing Options / Reports.)

These options apply to any of the grid-type reports -- tab views, single records, and any other "reports".

Always preview reports before printing -- When this option is set, you will get the chance to preview the printout before actually printing a report, even if you don't select **Print Preview** from the File menu. In fact, for reports that are printed from **Print** buttons in dialogs rather than the main menu or toolbar button, this option is the only way to get a preview. It's highly recommended that you leave this option turned on so that you don't accidentally print reports in a tiny font or that will span many pages due to an improper Fit Output to Page setting. Note that this option only applies to reports and other grid-type printing, not to receipts & invoices, mailing labels, envelopes, etc. For those, see the Always Preview Receipts option below.

Show printer setup dialog when printing reports -- by default, a dialog will appear every time you print with options for printer selection, layout, number of copies, etc. This requires an extra step to "OK" this dialog each time. By checking this option, that dialog is skipped so there's one less mouse click required. It will use the default settings from Printer Setup for reports. A small "Printing" message will appear momentarily just to let you know that it's printing, since there may not be any other indication if you're not near the printer.

Print in Black & White only -- When this is selected, all grid reports are simply black text, optionally with grid lines (according to the Grid Lines option described later). When not selected, the grids will use the exact colors as seen on the display, including the gray headers and the color-coded reservation status. Black & White will result in more readable reports on non-color printers like laser printers, and also helps save ink and can speed up report output on color printers. It's common to want some reports printed in black & White and others in color, so this option is also available under **File** in the main menu for easy access.

Zoom percent (100 = normal) -- This affects any of the grid reports, as long as the Fit Output to Page option is *not* set. With the 100 percent value, the printed grid will be approximately the same physical size as on the computer screen. You can adjust this value to suit your preferences. Set it to a smaller value, for instance 80 percent, to fit more on a page. If you want a larger printout, perhaps for posting the day's arrivals on a bulletin board, set it to a larger value like 125.

Fit Output to Page Horizontally -- When this is selected, the font size in reports will be shrunk or enlarged, as needed, so that they fit the width of the page. (The reports can still take multiple pages if it's longer than the page vertically, even with the horizontally-fit font.) This can result in some very small text (or very large text in some cases if the "Allow stretching" option is selected), but will save paper and make some reports easier to manage. When *not* selected, a fixed font size will be used (see Zoom percent below) no matter how large the report will be, which could cause the report to span many pages horizontally and/or vertically. It is common to want some reports printed with this option set and others without it, so this option is also available under **File** in the main menu.

Allow stretching to the full width -- When this is selected along with Fit Output to Page Horizontally, the font of any grid-report will be enlarged so that the report fills the entire width of the page if necessary. This is not normally desired, but might be useful to print out extra-large text for posting vacancies in a window, for instance.

When printing single records...

Skip blank fields (when printing single records) -- When using the Print button from dialogs such as Reservation Details, Site Details, and Customer Details, this option will shorten the output so that it only shows fields that are filled in. This will usually result in a printout that will fit on a single page.

Use a grid format (when printing single records) - When using the Print button from dialogs such as Reservation Details, Site Details, and Customer Details, this option will make the printout be in a grid. When turned off, the printouts will be in columnar text format, which is faster and uses less ink.

Report footer text -- This is normally the program name, for your reference as the source of any reports printed. If necessary, you can change this to other text (or blank it out).

Receipts Settings

(Accessed through Maintenance / Printing Options / Receipts, or File / Printing Options / Receipts.)

Note that these options apply mainly to the "default" receipts and forms or any custom forms derived from them. Custom forms can also incorporate these settings if desired, or they may be completely ignored -- see the Forms Setup section for more details.

Settings here are general receipt settings that apply to all types of receipts. Settings specific to Reservation receipts are found under the Reservations tab.

Unbound receipt default format -- Select the receipt format to use when printing a receipt for Unbound Transactions. This is typically for merchandise sales, so the Quick Receipt is the initial default.

Copies -- If you usually print duplicate receipts, you can change this to **2** so that you don't have to change the number of copies every time you print a receipt. (You can still change the number of copies on the print dialog when printing -- this just determines the default number.)

Always Preview Receipts Before Printing -- When this option is set, you will get the chance to preview the printout before actually printing a receipt. (This option is the only way to get a preview for receipts.)

Show printer setup dialog when printing receipts -- When checked, a dialog will appear every time you print with options for printer selection, layout, number of copies, etc. This requires an extra step to "OK" this dialog each time. By unchecking this option, that dialog is skipped so there's one less mouse click required. It will use the default settings from Printer Setup for the selected receipt type and the number of copies selected above. A small "Printing" message will appear momentarily just to let you know that it's printing, since there may not be any other indication if you're not near the printer.

Show transaction category for charges (eg: "Gift shop : " prefix before description) -- Charge transactions always have a transaction category and a description. Generally the description is enough to show on the receipts (and the description defaults to the same as the category when entering transactions), so this option is disabled by default. If you want to make sure the category is also printed on receipts (if not included in the description already), enable this option.

Show tax details on receipts -- by default, each line for sales tax or other tax category will show the amount taxed and the percentage rate, like (\$20.00 @ 8.25%). If you prefer not to have that information printed on the receipt (for instance to keep customers from noticing the actual tax rate), you can disable this option.

Combine taxes of the same kind into a single line on receipts -- When entering transactions, taxes are usually added automatically. This can result in multiple Tax transactions of the same kind, especially when entering counter sales. This option, which is enabled by default, will combine all taxes of the same type into one line (total) on the receipt. Different tax types, for instance Sales Tax and Hotel Tax, will still be on separate lines. If you need to see each tax entry separately, then turn this option off.

Show the current date on all receipts -- This option will put the date on each receipt (when it's printed), either in the upper right or lower right corner depending on the format.

Show 'Change' amount on receipts for payments with amount tendered/change due -- When a Cash payment or other payment method with an "Amount tendered" is entered different than the amount to pay, the receipt will normally show the full amount tendered and then a separate "Change" amount that was given. You can disable this option to avoid printing the Change on the receipts and instead just show the single payment amount.

Show Receipt # on receipts -- If this is checked, one or more receipt numbers will appear on receipts. Note that the receipt numbers are not terribly meaningful for reservation receipts (they are designed for point-of-sale receipts), but you can include them for reference. Each receipt number, if there is more than one, will appear on a separate line. This could significantly reduce the amount of space available for printing the transactions. Also note that "Receipt #" is the default name of this field, but if you prefer "Invoice #" or some other name, you can change this by editing the name (Short Label and Report Heading) of this field under *Define Data Fields / Transaction Fields*.

Limit to the ?? most recent unique #'s -- Enter the max number of unique receipt #'s to show on the receipts. Normally it will show a list of receipt #'s for the printed transactions (see above), but if it's more than a few then it can cause the receipts to be too long for the page, showing other information off the end. Use this to limit the number of lines used for receipt #'s

Wrap Memo transactions to multiple lines if longer than ... characters -- This should be set to a reasonable line-length for a maximum memo length per line. If a memo longer than this is entered, it will be automatically split into multiple lines (transaction entries) so it doesn't cause the Transaction table to stretch so far as to require scrolling to see the last column. This also helps printed receipts, since the receipts have a limited length per line for descriptions (assuming a "Printed Memo" is entered).

3" Receipt printer fixed-pitch font -- If you are using a receipt printer, this should be set to the name of the printer's "native" fixed-pitch font, generally a font that is used for 40-column text output. This is used if the receipt format "3" Receipt Printer, fixed-pitch font" is used for printing transaction receipts. You will need to find the name of the font from the printer's manual or programming guide. This font often refers to "cpi" (characters per inch), like "FontB11", "ANK 15cpi" or "21cpi". If you don't know the name, try "Courier New" to select the Windows fixed-pitch font. This may also work with your printer.

Size -- This is the font size to be used with the selected 3" printer font. In some cases this needs to be adjusted to get 40 columns to fit on the printer.

Columns -- This is only used with the fixed-pitch font receipt format for 3" receipt printers, and specifies how many columns are available on the printer. Most receipt printers support 40 columns, but some can use a smaller font for more columns. If one letter is getting cut off, try 39 columns.

3" Receipt printer proportional font -- If you are using a receipt printer but prefer a fancier non-fixed-pitch font, this can be set to the name of a proportional font that the printer supports. For some printers, e.g. the STAR SP300 or SP500, this can be any Windows font like Arial or Times New Roman.

Park shown on non-reservation receipts -- If you have multiple park records set up with different name and/or address information, the first one is used by default for transaction receipts with no site/reservation involved, because it can't determine which park the transactions apply to. The first park record may not be appropriate in all cases, especially if you're using multiple networked workstations where each park has its own workstation. On each workstation, you can select the appropriate park record to be used for unbound transactions. Note that this also applies to printing envelope return addresses.

Reservations Settings

(Accessed through [Maintenance / Printing Options / Reservations](#), or [File / Printing Options / Reservations](#).)

Note that these options apply mainly to the "default" reservation receipts and forms or any custom forms derived from them. Custom forms can also incorporate these settings if desired, or they may be completely ignored -- see the Forms Setup section for more details.

Reservation Receipt default format -- Select the receipt format you will use most often. You can select the format any time you print a receipt (without coming back here), but setting the most common one here will save steps later. See the section [Working with Transactions](#) for details on each format.

Quote/Confirmation default format -- Select the receipt format to use when printing from the Quote/Confirmation function on the Reservation Details dialog. This is typically the Confirmation Letter.

Copies (separate entries for each default format above) -- If you usually print duplicate receipts, you can change this to **2** so that you don't have to change the number of copies every time you print a receipt. (You can still change the number of copies on the print dialog when printing -- this just determines the default number.). Note that this does not affect the batch receipt printing or monthly billing.

Show separate charges for each synchronized site on receipts by default -- This simply determines whether the "Use separate entries for each site" option is checked by default when selecting rates. It can be changed when selecting rates, so this option just determines the default setting. See [Selecting Rates](#) for more details.

Show Site name/abbr in description of each Charge transaction even if only one site -- Normally the site name/number is only shown for each Charge item if there are multiple synchronized sites and the "Show separate charges..." option above is enabled. If you want the site number to be shown for each charge even if there's only one site (e.g. for clarity on reports), then select this option. (For synchronized sites, it would still only be shown when "Show separate charges" is also enabled). Note that if the reservation changes sites, this can cause additional transactions to be added when auto-calculating, e.g. removing the charges for the old site and adding the charges for the new site.

Use the site "Name" on reservation receipts -- (checked by default) Normally the full site name is used on receipts, but if you prefer the short Abbreviation (from Site Details), then uncheck this option.

Use the site "Type" on confirmations instead of the site name -- If you prefer not to guarantee specific sites when confirming reservations, select this option to show only the site type, not the name. This only affects the Confirmation Letter receipt format. Note that if you have the "Show separate charges..." option set above, this option will also remove the site names from the charge detail descriptions, *if* the confirmation is printed from the Quote/Confirmation function on Reservation Details (but a separate charge will still be shown for each site).

Show all linked sites on receipts -- For reservations that are linked to other synchronized or sub-member reservations, the transactions on a receipt generally apply to more than one site. With this option selected, the sites for the other reservations are listed at the bottom of the receipt. If the other reservations are for different dates or times, then the dates and/or times are also shown. This option is usually desired, but it can be disabled if this adds too much clutter to receipts.

Show quantity details in descriptions -- When a charge is for multiple sites, or involves a quantity like extra adults, detail is added to the description like "(3 x 4 sites)" or "(3 x 2)". While this is helpful, it can also result in extra transactions and confusion when quantities are changed and auto-rates are used. For a cleaner receipt, disable this option.

Credit Card Settings

(Accessed through [Maintenance / Printing Options / Credit Cards](#), or [File / Printing Options / Credit Cards](#).)

These options apply when a credit card payment or refund is entered. Note that some of these options apply mainly to the "default" receipts and forms or any custom forms derived from them. Custom forms can also incorporate these settings if desired, or they may be completely ignored -- see the Forms Setup section for more details.

Show credit card information on receipts -- This option will show the credit card number (masked with X's except for the last 4 digits), expiration date, etc. on the receipts if the last payment (or refund) was made with a credit card and the information was entered.

...only on 3" receipt printer formats -- Set this to designate that the credit card information is only included on 3" receipt printer receipts, for instance if you don't want it to appear on the ticket form, confirmation letters, etc., but want it to show on the cash-register type receipts.

Include credit card signature line -- If you're showing the credit card information, you can also opt to include a signature line on every receipt that has the credit card information. This is typically only enabled if you're doing the credit card processing through Campground Master (otherwise your credit card machine prints the appropriate signature ticket), and even with Campground Master doing the processing, you may prefer the auto-print option below.

...only if authorization is processed --Set this option to only show the signature line if Campground Master actually does the processing.

... skip for EMV-processed cards -- Set this option to skip the signature area if the card was an EMV card processed on an EMV terminal.

Automatically print a credit card signature slip when credit card payment is entered -- This is the preferred option if Campground Master is doing the credit card processing. This will print a slip for the customer to sign as soon as the Enter Payment dialog is closed, so it's faster than you printing it manually.

... and also when a Deposit is entered (else just Payments and Refunds) -- Set this if you also want credit card slips printed for Deposits. If deposits are usually done by phone and you don't need a credit card slip printed, then you may want to uncheck this.

...only if authorization is processed -- Set this option to only auto-print the signature slip if Campground Master actually does the processing.

Credit card slip format -- There is a special "Credit Card Slip" format that's normally used, designed for 3" receipt printers. This prints the minimal necessary information, with only the payment transaction instead of all transactions. (Note that this format always goes to the printer set up as the "Receipt Printer", but it doesn't have to be a special printer -- you can make a normal printer simulate a 3" printer by selecting a paper size like a 4x6 index card, for instance.) If you prefer to print one of the other formats, with complete information instead of the summary, you can select that here.

Copies (non-EMV or EMV) -- You can change this for instance to print 2 copies of the credit card slip when it's processed, so you can give one to the customer also. This isn't strictly necessary because the credit card info can also be added to their normal receipt (see above). It's generally more desirable to let it just print one credit card slip, which they sign for you to keep, and then print one full receipt for them. This is because the credit card slip includes no details of the sale, only a total, so they will need a full receipt anyway. There's a separate setting for EMV-processed cards since those may not require you to keep a signature slip for yourself.

Offsets Settings

(Accessed through [Maintenance / Printing Options / Offsets](#), or [File / Printing Options / Offsets](#).)

Note that these options apply mainly to the "default" labels and envelopes or any custom forms derived from them. Custom forms can also incorporate these settings if desired, or they may be ignored -- see the Forms Setup section for more details.

Printer Offsets -- You can fine-tune the printer offsets for printing forms that require precise positioning such as mailing labels. The Top and Left numbers represent the closest point to the edge that the printer can print. If you find labels printing too close to the top (or left), you will need to *decrease* the offset to compensate.

Envelopes

These settings apply to printing Envelopes (e.g. Reports / Customer Envelopes).

Address position for Envelopes -- Set the offset from the edge of the envelope where you want the "to" address to appear.

Print the park's return address on envelopes -- If this is set, the return address will be printed in the upper left corner of the envelope. (Leave this off if your envelopes have your address pre-printed.)

Return address position for Envelopes -- Set the offset from the edge of the envelope where you want the return address to appear.

Letters and Invoices

These settings apply to most of the receipts formats, e.g. Full-page invoice/receipt/statement, register-style statement, and confirmation letters. They don't apply to the Ticket Form, since positions are fixed for that. They also don't apply to the "Quick Receipt" format, since that's not intended for mailing.

Address position for Letters and Invoices -- Set the offset from the edge of the page where you want the address to appear for full-page invoices and confirmation letters. This is important if you use window envelopes. Otherwise, you can set them closer to the top of the page to save space for more transactions.

Position return address for window envelopes -- Select this if you use 2-window envelopes and need to position the address. Note that on the full-page invoices, the "outlined block" header won't be used if this option is selected, since that would likely overlap the return address. Also note that the park phone numbers, etc. will start 0.2 inches below the return address, to keep it from showing in the window (as opposed to only 0.05 inches gap if this option is not selected).

Return address position for window envelopes -- set this as needed to get the address in the correct position.

Notice Messages, Confirmation Letter and Window Tag text

These setup dialogs (found under Maintenance / Printed notices & text) allow you to edit the text used for certain sections of receipts. Each different type of receipt has different text that can be set up.

Note that these options apply mainly to the "default" forms or any custom forms derived from them. Custom forms can also incorporate these settings if desired, or they may be completely ignored -- see the Forms Setup section for more details.

Ticket Form

The Notice text for the Ticket Form should remain approximately the same size as the default text, so it fits in the designated area of the receipt.

Reminder -- the "Additional Notes" section that can appear on the lower left side of the Ticket Form receipts is set up in the Parks Setup for each park record (so each park's receipts can have a different set of notes).

Invoices, Receipts, and Statements

These can have any amount of Notice text at the bottom, in addition to a guest signature after the notice. The amount of space allocated for the notice is also selected, so it can start any number of inches above the bottom (this can also be a decimal number, like 2.5). Note that there are separate settings (through separate selections under the Park Setup menu) for E-mail invoices, receipts and statements.

Confirmation Letter

The Confirmation letter 'Above Transactions' text may be just about any length (allowing space for transactions, etc. below it of course). You can also add line breaks, blank lines, etc. using the Enter key just like typing a letter. The Notice text is set up similar to the text for Invoices, etc., with an optional signature line. You can also set the font size for the bottom text, so it can be made to blend in with the top portion better if you wish.

If you have the "Site_Confirmation_Text" field enabled for sites (see Data Field Definitions), you can have special bottom text appear for individual sites. The Bottom Text from this dialog will be used as the default for sites without special text entered, but you can override it by entering Confirmation Text in Site Details.

There is also an option to show only the deposit paid and balance due on the confirmation letters. This is useful if you want to show a lot of text, since it takes much less room than the full transactions table. It may also be considered a "neater" format. In addition, when using this option you can show how many adults and children the rate is based on (since the transactions detail information is not shown, this might be important), and optionally include pets, extra vehicles and extra trailers. Note that the "Deposit Paid" amount will normally

only include Deposits and Deposit Transfers into the reservation, and a "Balance Due" will only be shown if there is a balance greater than zero due (e.g. charges are added greater than any deposits made). If you want to also include Payment transactions with the Deposit amount, check the box to include "Payment" transactions.

Show "Check In/Out" instead of "First/Last Night" -- this option will show the dates as the actual dates of check-in and check-out (departure), rather than first and last night (the Check-In day is the same as First Night, but the Check-Out day is usually one day later than Last Night). This is largely a matter of preference, but can avoid some confusion by the customer. Note that this only affects the Confirmation letter, not other receipts and invoices.

Note that there are separate settings (through separate selections under the Park Setup menu) for Confirmation E-mails.

Window Tag

The Window Tag bottom text can be as large as needed, with the limitation being the size of half of the page. Unlike other receipts, you don't specify a starting position -- it always starts slightly below half the page height (e.g. it assumes you will fold the page in half for use as a window tag). If you don't need text on the bottom of the window tag, just clear out the entire edit box

3" Receipt Printer bottom text

The bottom text for this can be any length needed, and simply starts 1 line below the end of the receipt. All text will be centered, and is generally limited to 40 characters per line, but will automatically wrap around. Note that you might need to add additional blank lines below the text so that the paper scrolls out enough to tear off the receipt. You can force a new line or insert blank lines as needed using the **Enter** key.

If you want to send special control codes to your printer, for instance to activate the paper cutter, you can add those here. (This usually only works if you're using the Direct to Port printing option and not going through a driver, depending on your printer.) To send special codes, enter them as hexadecimal values preceded by "**\X**" -- like **\X07** to send the ASCII "BEL" character. Be sure to use the backslash character (\), not the forward slash (/).

Credit Card Slip bottom text

The bottom text for this can be any length needed, and simply starts 1 line below the signature line. Formatting is the same as for the 3" receipt printer bottom text.

Receipt Printer USB/Driver Settings

If your printer connects to the computer through a USB port (instead of the old parallel or serial port connection), or if you need to share the printer with other computers over the network, then a driver must be installed for the printer. Receipt printers don't normally ship with a driver disk, so you need to contact the printer manufacturer to get the driver. You may also get a copy of the driver from your reservation software provider.

First you will need to install the driver in Windows. This is usually best done before connecting the printer itself. Then connect the printer, turn it on, and let Windows recognize it.

Note: In some cases, Windows does not select the correct port for the printer automatically. After connecting the printer and turning it on, go to the Start menu, Control Panel, Printers & Faxes. You should see the receipt printer listed there. If it shows "Not available" for the status, then right-click on it and select Properties. Go to

the Ports tab, and see which port is selected. Assuming it's a USB printer, for instance, make sure the port selected is a USB port, not an LPT port. To test it, you can click on the General tab and print a test page.

Avoid making it the "default printer"

It's highly recommended that you do **not** set the 3" receipt printer as the "default" in Windows. Your normal printer (e.g. laser or ink jet) should be the default. So after you install the driver, you should verify that Windows did not make it the default (and change it if needed).

Also, if you're using Windows 10 (or later?), you should read this article about keeping Windows from changing the default printer on its own:

<http://campgroundmaster.com/news/win10printer.html>

For more complete information on configuring and troubleshooting your receipt printer, see this page on our web site:

<http://campgroundmaster.com/receiptprinter.html>

Configuring the printer in Campground Master

Once the printer driver is installed, go to File / Printer Setup / Receipt printer (3" paper) - using a Windows driver (USB printer). Select the receipt printer from the printers list.

There are also a few other items that may need to be configured. We recommend using the fixed-pitch font option for cleaner looking receipts, so here are the settings for that:

- **Receipt font** -- Go to Maintenance / Printing Options. Under the Receipts tab, set the 3" receipt printer fixed-pitch font and Size to the appropriate "native" font for the printer you're using. This may require some information from the printer maker, but the normal font for Epson printers is "FontB11", with a size of 9. If you're using the thermal printer (Epson TM-88 series), a font of "FontA11" may work better. Note that those are the number eleven ("11") in the font names, not the lowercase letter "L". The Columns is almost always 40.
- **Default receipt selections** -- if you want to use the receipt printer by default for reservations, unbound transactions, POS sales, or credit card receipts, then go to Maintenance / Printing Options. Under the Receipts tab, and also under the P.O.S. Receipts tab (if you have the POS option), select the default format for the desired receipt types to be 3" Receipt Printer, fixed-pitch font. Under the Credit Cards tab, select the credit card slip format to be Credit Card Slip, fixed-pitch font.
- **Cash Drawer** -- if you have a cash drawer connected to the printer, the Cash Drawer Setup settings should be set to Send command through the 3" receipt printer driver, with the appropriate command font selected (usually "control"). The Characters to send should be set appropriately for the printer model.. For Epson printers, this will be 65.
- **Preview / Printer Dialog** -- once things are working as expected, you may prefer to disable the print preview and the extra printer dialog that opens when printing receipts. This is done through Maintenance / Printing Options, under the Receipts tab (and POS Receipts tab, if you have the POS option).

At this point it should be ready to use. You can open a Transactions window (e.g. Reservation Transactions, Unbound Transactions, or POS Sales Entry), enter a test Charge & Payment (if there isn't something already there you can print), select the appropriate receipt format (from the drop-down list above the "Print All Transactions" button), and click the Print All transactions button.

Receipt Printer Direct to Port Settings

This is an outdated way to configure a receipt printer, since most are USB now. However if appropriate interface requirements are met (parallel or serial interface available), and assuming you don't need to share the printer over the network, then this method is actually preferred since it results in faster printing. No printer driver needs to be installed when using Direct to Port.

Note: Once this option is enabled, an additional 3" receipt printer receipt style will be available for direct-to-port printing (e.g. in the drop-down list near the Print Reservation Receipt button, in Reservation Transactions dialogs. You must select the receipt format that has "**direct to port**" in the name in order for it to print using these direct-to-port settings. You may also want to select this format as the default through Maintenance / Printing Options. This also applies to credit card slips, if you're processing credit cards through Campground Master.

IMPORTANT: If you have a Windows printer driver installed on the same port (through Control Panel / Printers), it may interfere with the direct-to-port function. You should delete any printer from the Windows printer list that's on the same port you're using for the receipt printer direct-to-port setup. However, Windows still needs at least one printer defined as a default printer, so you can set up a Generic / Text printer on some other port (even if another printer doesn't really exist, or perhaps set up a networked printer).

Configuring the printer in Campground Master

The function to enable Direct to Port printing is found under File / Printer Setup / Receipt Printer (3" paper) - Direct to Port (Serial or Parallel printer).

To enable this option, simply check the Direct-to-port printing enabled box on this dialog and select the interface type below.

Interface port -- select the port that the printer is connected to. If it uses a parallel port, that's usually "lpt1".

Baud, Parity, Data bits, Stop bits -- These only apply if a serial port is selected (com1 through com4). Enter the appropriate values according to your receipt printer manual. (Most are set up for 9600 baud, no parity, 8 data bits, 1 stop bit.)

Additional Setup Information

Once the Direct to Port option is enabled, there are a few other items that may need to be configured:

- **Default receipt selections** -- if you want to use the receipt printer by default for reservations, unbound transactions, POS sales, or credit card receipts, then go to Maintenance / Printing Options. Under the Receipts tab, and also under the P.O.S. Receipts tab (if you have the POS option), select the default format for the desired receipt types to be 3" Receipt Printer, direct to port. Under the Credit Cards tab, select the credit card slip format to be Credit Card Slip, direct to port.
- **Cash Drawer** -- if you have a cash drawer connected to the printer, the Cash Drawer Setup settings should be set to Send command directly to the hardware port, with the appropriate interface selected (usually LPT1). The Characters to send should be set appropriately for the printer model.. For Epson printers, this will be 27,112, 0, 60, 60.
- **Preview / Printer Dialog** -- once things are working as expected, you may prefer to disable the print preview and the extra printer dialog that opens when printing receipts. This is done through Maintenance / Printing Options, under the Receipts tab (and POS Receipts tab, if you have the POS option).

At this point it should be ready to use. You can open a Transactions window (e.g. Reservation Transactions, Unbound Transactions, or POS Sales Entry), enter a test Charge & Payment (if there isn't something already

there you can print), select the appropriate receipt format (from the drop-down list above the "Print All Transactions" button), and click the Print All transactions button.

Cash Drawer Setup

This configuration function, accessed through the *Maintenance* menu, is used to set up the options and hardware commands required to open an electronic cash drawer.

Most cash drawers are connected through a 3" receipt printer, and are opened with a command to the same port (if using a direct serial or parallel interface) or by printing commands in a special "command" font to the printer if using a Windows printer driver (e.g. for a USB printer). Either of these methods is supported, as well as interfacing directly to a cash drawer without a receipt printer (provided the cash drawer has a serial or parallel interface, or is an APG brand USB drawer). The method used to command the cash drawer depends on the type of hardware interface used, which in turn may depend on the receipt printer interface.

Note that the options are set up for commanding through an Epson printer driver by default, so if that's what you're using then all you need to do in many cases is check the "Cash drawer is present" option. If you're not connecting the cash drawer to the printer, or you're not using a printer driver or using a different brand of printer then you'll need to adjust the options accordingly. Note that we cannot guarantee support for connecting through any receipt printer brand other than Epson, or any USB connection cash drawer other than APG brand.

Networking note: These settings are separate for each workstation, and are specifically *not* synchronized when a *Network Functions / Synchronize local options* is performed. If you have more than one workstation on a network, each one must be set up individually since it may have different equipment.

Connecting a drawer through a Receipt Printer

The cable typically used for this has connections similar to a telephone. However, one end is smaller than the other, and the cable only works one way. The smaller end should connect to the printer, and on Epson printers it goes in the connector next to the power cable. The larger end should fit in the cash drawer.

Direct To Port -- If using a the Direct to Port setup for the receipt printer, the option Send command directly to the hardware port should be selected, with the appropriate interface selected (usually LPT1). The Characters to send should be set appropriately for the printer model.. For Epson printers, this will be 27,112, 0, 60, 60.

USB printer, and/or using a Windows printer driver -- If you can't use the Direct to Port connection (e.g. it's a USB printer or you need to share it over the network), then a driver must be installed for the printer. In this case, the option Send command through the 3" receipt printer driver should be selected, with the appropriate Command font entered (usually "control", for Epson printers). The Characters to send should be set appropriately for the printer model. For Epson printers, this will be 65.

Connecting a drawer through a USB interface (APG cash drawers only)

This is the recommended method if you don't plan to use a receipt printer and must get a drawer with a USB interface, but only the APG brand of USB cash drawers is supported at this time. The driver for these should be included with the drawer -- you will need to follow the included directions to install the drawer, making a note of the USB port used (usually USB1 or USB0).

Once the driver is installed, you can select "Send command through USB port", and choose the appropriate USB port. The easiest option is to select the "QuickFire" option for the USB port. This is a special interface from APG that is supposed to locate the drawer automatically. However if that doesn't work, then try choosing the port that was shown when you installed the driver.

Connecting a drawer through a Serial interface

This is only advisable if you don't plan to use a receipt printer. The connection must be made directly to a serial port on the computer -- a USB/Serial converter will not work. If your computer does not have a serial port (also known as a "COM" port) built in, you can usually have a technician add one to it.

Connecting a drawer through a Parallel interface

This is only advisable if you don't plan to use a receipt printer, but do have a parallel printer (e.g. laser or ink jet printer). The connection must be made directly to a parallel port on the computer -- a USB/parallel converter will not work. In addition, there must be a parallel printer connected, which would now connect to the drawer as a pass-through connection. The drawer will not work if there is not a printer connected to it and turned on.

Setup Options

Cash drawer is present -- Obviously this should be checked if you want the software to command the drawer. The function to Open Cash Drawer will only appear on the dialogs if this is checked, and it will only open automatically when printing a receipt if this is checked. All other settings are disabled unless this is checked. Note that if a cash drawer is removed, or the database is moved to a computer without a cash drawer, it's a good idea to uncheck this so it won't send cash drawer commands to the port, possibly resulting in affecting other devices like a printer or modem that's now connected to the same port number.

Show an "Opening Cash Drawer" message while opening drawer -- Check this option if there is a delay opening the drawer (some printer drivers can cause a few seconds' delay). This simply serves as an indication that it did send the command, so you don't have to wonder while you wait.

Send command directly to the hardware port -- Select this to send the command directly to the port. This option is fast and won't feed extra paper, and doesn't require a receipt printer driver to be installed. This can be used whether or not the drawer is attached to a receipt printer, assuming the printer has a special pass-through command to open the drawer. Of course if the drawer is attached directly to a serial or parallel port, this is the only option you can use. Conversely, if you have a USB receipt printer and the drawer is connected to the printer, then this option cannot be used

Baud, Parity, Data bits, Stop bits -- These only apply if commanding directly through the port and if it's a serial port (com1 through com8). Enter the appropriate values according to your cash drawer or receipt printer manual.

Send command through the 3" receipt printer driver -- Select this to send the command through the Windows printer driver, but as text printed in a special font. For instance, Epson printers can be commanded to open the drawer if an 'A' character is sent in the "control" font. Note that this always sends it to the printer designated for the 3" receipt printer (under File / Printer Setup), even if you're printing a receipt to a different printer. It also requires the special printer driver from the receipt printer manufacturer.

Send command through USB port -- Select this if it's a USB cash drawer interface. This only works for APG cash drawers with a native USB connection -- not for serial or parallel drawers connected to a USB port through an adapter. You will also need to select the USB port that was assigned when installing the cash drawer driver, or select "QuickFire" in the port list to use a special interface that locates the drawer automatically.

Send command to another Workstation -- Assuming you have the Networking option, you can use this to tell it that the cash drawer is physically connected to a different workstation (allowing one drawer to be shared between workstations). Just enter the workstation ID that has the drawer. Of course you should make sure

that the workstation you're sending the command to has the cash drawer set up as local (direct, printer, or USB interface selected).

When printing a receipt.... -- This selection simply determines when (and if) you want the command to be sent automatically when a receipt is printed. Usually you want it to be sent before the receipt text is printed, so the drawer opens immediately. However this can be changed as needed (it may even be necessary to send it after the text for it to work properly with your printer). Note that it doesn't matter which receipt format you're printing -- even if you print a full-page receipt to a laser printer, the cash drawer command will be sent separately to open the drawer, even if it's connected through a receipt printer.

Open drawer immediately after a payment is entered -- Select this option particularly if you don't always print receipts, but want the drawer to open (and any change due shown) as soon as a Payment is entered on the Transactions or POS dialog. This will open the drawer for any payment, refund, or deposit transaction. If you only want it to open for Cash payment methods, then also check the "... **only if it's a Cash payment**" box.

Characters to send -- This is the most critical part of course. Refer to your printer or cash drawer manual if your printer isn't one of the examples listed on the dialog. The command string must be entered as a string of decimal numbers separated by commas. (Plain text entry is not possible because most command codes use non-printable characters.)

Test -- After everything is set up the way you think it should work, click the Test button to send the specified commands.

Credit Card Processing

Overview

This section primarily applies if you plan to process credit cards directly through the software when making payments, instead of using a separate credit card terminal. The Processing Setup dialog is accessed through Maintenance / Credit Cards.

Processing credit cards through the software helps keep a record of credit card information, avoids duplicate entry into a separate terminal (and possible mistakes), and assures that credit card payments can't be recorded without the credit card charge being approved.

IMPORTANT: If you're entering credit card information in Campground Master, even if you're not processing them, be sure to set the Credit Card Security options to limit your company's risk and liability!

PCI Compliance note: Refer to the **PCI/PA-DSS Compliance Guide (see the *Introduction* chapter)** for important details about proper security procedures.

Processing Software Options

Credit card processing is supported through certain 3rd-party authorization processing software or gateways. The processing software is required to handle the actual communication with the merchant bank, which is only possible with certain licensed providers. These do require a reliable internet connection to operate.

Campground Master is currently compatible with these products (each has its own section explaining the setup details):

X-Charge -- (Also now known as OpenEdge) This provider integrates seamlessly with Campground Master. There is no charge for this integration no matter how many workstations you have, and it works in conjunction with their own merchant services (so support for both the software and the merchant services are provided by the same company). Their discount rates are very competitive (they can provide you with a detailed comparison to your existing merchant statement), and it's simple to get set up.

MerchantWare Web Service (by Cayan / TSYS) -- You can use this as a gateway to most 3rd party merchant services, or directly with the Cayan / Merchant Warehouse merchant services. Like X-Charge, there's no software to buy. In fact you don't even need to install separate software, as all processing is done through a direct web connection. However any maintenance functions (settlement reports, etc.) need to be done through a web interface.

MCPS (Merchants' Choice, or PaySafe) -- This is another alternative that you may consider if you can change merchant accounts, since it's tied to Merchants' Choice merchant services. Like X-Charge and MerchantWare, there's no software to buy. However any maintenance functions (settlement reports, etc.) need to be done through a web interface.

EMV (chip card) and Debit/PIN support

EMV transactions and Debit cards with PIN are currently only supported through X-Charge and Cayan MerchantWare Web. If using any other processor, including MCPS, we recommend that you use the Cayan MerchantWare gateway for processing so that you have full functionality.

Obsolete interfaces:

PC Charge (by Verifone) -- "**Not supported**". While Campground Master will interface with IC Verify, we can no longer recommend this software as an option because it's no longer supported by the maker, and will not work in current versions of Windows.

IC Verify (by FirstData) -- "**Not supported**". While Campground Master will interface with IC Verify, we can no longer recommend this software as an option because it's extremely difficult to implement the newer versions (e.g. 4.2).

Hardware Setup

Processing is usually done through the internet, so the computer with the processing software (and in some cases this would be all computers) should have a high-speed internet connection.

You will also probably want a mag-stripe reader for swiping credit cards -- not only does this save a lot of time and eliminates mistakes, most merchant services also offer a much lower discount rate for swiped cards. A USB reader works best -- it must be a non-encrypted "keyboard emulation" device (which is not the same as a "HID" device). The reader must support Track 1&2 reading, but may also be a 3-track reader. MagTek and ID Tech make mini-mag readers that you can stick onto your keyboard or monitor. See our web site for current models.

Note that the reader should be set to either include a CR/LF after each track or the "sentinel" characters, or both. (Do not use the Tab character as a delimiter.) These settings are usually set with either dip switches on the bottom of the reader or configuration software, but the default settings are typically correct so no action is necessary.

It's also a good idea to use a 3" receipt printer, especially for printing the credit card signature slips. These can be set up to print automatically on the receipt printer when the credit card payment is processed, separately from the customer's receipt. A normal full-size printer can also be used for the credit card slips, but it's not as convenient.

Any receipt printer with a Windows driver can be used, or any printer connected directly to the parallel or serial port. Examples of receipt printers that work well are:

- TMU220 Epson U200 series, a basic impact printer
- TMT-88v Epson TM-88 series, a fast thermal printer

You can purchase the mag-stripe readers and printers directly from us -- contact us or see our web site for details.

Receipt Printer Setup

If you're using a 3" receipt printer to print credit card slips, you should also go to File / Printer Setup to configure the printer, and configure Printing Options. See the chapter "*Setting up your Campground Database*" for details. There are also section in this chapter (Maintenance Functions) which detail Receipt Printer settings for either Direct-to-Port or USB/Driver configurations.

Also, go to Maintenance / Printing Options / Credit Cards to choose a default credit card slip format and other applicable settings for printing credit card information and signature slips.

Processing Setup Options

The Processing Setup options are accessed through Maintenance / Credit Cards / Processing Setup. These options are primarily related to the actual processing software and mag-stripe reader. See Maintenance / Printing Options / Credit Cards for options related to what information is printed on receipts, and File / Printer Setup to configure the appropriate printer (e.g. if using a 3" receipt printer).

Note: All credit card processing settings are local to each workstation. Be sure to update all computers when setting up or if any change is required.

Enable credit card processing -- This option must be enabled to set any other options, and to enable the "Process" function on the payment entry dialogs.

Processing software used -- Select the gateway or type of processing software being used. See Processing Software Options for details.

Copy settings from the Master workstation -- This button (only visible to client workstations) will copy all applicable settings from the Master workstation, so you don't have to re-enter everything again on each client. This is applicable to XpressLink/Edgeline, Cayan MerchantWare, MCPS/T-Gate and PC Charge settings, as well as the general processing setup options on this dialog.

Send processing requests to the Master workstation vs. **Processing software is installed on this computer** -- This option was only important for older methods of credit card processing (X-Charge request file method, IC Verify, and PC Charge). For any of the newer methods, this choice is disabled and "Processing software is installed on this computer" will be selected.

Path to use for swiped cards -- (only used for obsolete interfaces).

Path to use for keyed-in cards -- (only used for obsolete interfaces).

Time-out for processing -- Enter how many seconds to wait for a response. This should allow enough time for the processing software to connect, process, and return a response. This value only applies if processing locally. If it's sending requests to the master workstation, the master's time-out value is used. Note that in a multiple-workstation environment, you should allow extra time in case it's busy with another workstation's request.

Also note that for some processing methods, this timeout may be ignored and a built-in time-out is used (e.g. for internet requests using MerchantWare and MCPS).

IMPORTANT -- If Campground Master times out while the processing software is still trying to connect, this will result in duplicate charges to the customer's credit card! If you ever get a time-out

message in Campground Master while the processing software is still attempting to connect, increase the time-out setting. (And be sure to void the extra charge through the processing software's interface.)

WARNING -- The time-out value is only intended as a fail-safe in case the processing software fails or is not running. Make sure the time-out value is sufficient for the processing software to give up **before** Campground Master times out.

This workstation's "User" number -- (only used for obsolete interfaces). If enabled, this designates a unique user/computer number to avoid conflicts when processing from multiple computers. For some processing options, this determines the file name used for the request/answer file. This is normally 1, but if you have multiple workstations then each one will have to have a different number. Note that the lowest user number for the processing software is 1, not 0 -- so don't use 0 like you do for the networking ID.

Allow Partial Approvals (else will decline the charge if full amount not available) -- Selects whether partial approvals will be approved (for the partial amount) or declined (if the full amount cannot be approved). This depends on support by the software/gateway used and also the end processor, so this is not guaranteed to have any effect.

AVS enabled -- You can set this if you want to use (and your processor supports) Address Verification. The Zip code and Address information will be included in the authorization request if it's available, and the response will show the AVS response.

CVV2/CVC enabled -- You can set this if you want to enter a CVV2/CVC code for credit card payments (the extra 3-digit code on the back of some credit cards, or the 4-digit CID code on the front of American Express cards). If your credit card processor supports CVV2, the response will be shown for this also.

Void transactions must be done directly with the processing software -- Normally you can do Voids directly in Campground Master by deleting the payment (or refund) transaction, and it will be processed accordingly. However, in some cases the processing software may not allow voids to be handled through Campground Master, so this option would be checked to allow voids to be deleted without processing. Do not check this option unless you always get an error message when trying to Void a transaction!

Forced Sales enabled -- If your processor enables forced sales (entering an approval code obtained by voice authorization), and you want your clerks to be able to do this, then check this option. An extra "Forced" button will appear on the payment entry dialog allowing you to do a forced sale.

Process swiped cards automatically -- This option saves a step when swiping cards -- as soon as the card is read (successfully), it will submit the payment for processing so you don't have to click the Process button. Note that if you select this option, you must enter CVV2/CVC code and/or address information **before** swiping the card! Also note that it might start processing automatically even without this option enabled, if you don't have either AVS or CVV2 enabled -- this can happen if the card swipe you're using sends an extra carriage return at the end of the swiped data, causing the "Process" button to be pressed. Enabling AVS or CVV2 will prevent this by putting an extra input field on the dialog so the carriage return doesn't go to the "Process" button.

Automatically close payment dialog if the transaction is approved -- This option can save yet another step. As long as the transaction is approved, the dialog will immediately close without requiring you to "OK" the approval message. The only drawback is that you won't be able to see the AVS or CVV2/CVC response codes.

Include billing address entry fields if AVS is enabled -- If you use AVS, Campground Master will automatically get the address information from a customer's record whenever possible. However if the customer record is not filled out yet, or if you're entering unbound/POS transactions with no customer information, you may want to enter this information manually. This option adds Zip/address entry fields that can be filled in when needed. You can also verify/change the information before processing as needed.

Card reader supports 2 tracks of data -- If you're using a magnetic strip reader and it's a Track 1&2 (or 3-track) reader, this option should be selected so that the program knows to expect 2 tracks of data before

processing it. If you want to submit both tracks of data to the processing software, you should select the "**Submit both tracks**" option also (it's not always required, but in some cases will help the authorizations go through).

Basic Setup - X-Charge

If using X-Charge (by OpenEdge) for your processing software, you should use their "XpressLink" interface method (now also known as EdgeLink). The "X-Charge (legacy)" option is available if needed for old installations, but this does not meet PCI compliance standards. XpressLink MUST be used if you are processing debit cards with a PIN pad or have a terminal with EMV/chip card support, and is also required for processing in Canada. Some other unique features when using XpressLink are:

- Requires that X-Charge be installed on each computer, not just the master.
- Supports Verifone PIN pads and combination swipe/PIN pads for debit card processing.
- Allows swiping the card after clicking the "Process" button, which adds a layer of security by keeping the full card information outside of Campground Master. This also means you can't view the card information, however you can still add additional charges to the same card later if needed.

EMV/chip card changes

A few new options have been added for better support of the new EMV terminals as well as tighter PCI security measures. X-Charge recommends that credit card numbers not be stored in Campground Master at all, and in fact won't process cards directly from Campground Master. This does NOT mean you can't store and retrieve cards, since X-Charge has the Vault function to store cards. It just means that you won't be able to see the full card number in Campground Master even if you're an Administrator.

The settings recommended for using X-Charge with an EMV reader are detailed below. These should be the only thing you need to change or verify when switching to an EMV terminal (other than the configuration of X-Charge itself).

Allow "Process" before swiping/keying in credit card -- This must be checked, since you can't swipe a card through Campground Master any more.

Allow swiping credit card before "Process" -- This must **not** be checked, since you can't swipe a card through Campground Master any more.

Allow keying in credit card before "Process" -- This should be checked for smoother operation. While you could uncheck this and always click Process first, this requires several extra steps in X-Charge that can get awkward. Feel free to try it either way to see which you prefer.

'Vault' keyed cards before processing -- This must be checked, if the above option is checked (see below for details).

Also, we recommend that you select (check) the "Never save credit card numbers" option in Credit Card Security Setup. Also leave the "Don't retrieve previous card information" option unchecked, since this will not pose any security risk if you're not saving cards in Campground Master. It will be able to retrieve them securely from X-Charge.

IMPORTANT: If you are not yet using an EMV card reader and want to swipe cards directly in Campground Master, then you must use the "**Open Integration**" version of X-Charge, not the "Secure" version -- otherwise, you will get an "invalid card" error when you try to process cards. (The Secure version does not accept credit cards from outside applications to maintain security, however since Campground Master is PCI compliant then it's safe to use the Open Integration version.) If you're not sure which one you have installed, contact X-

Charge. Also, if you open X-Charge and check Help / About..., it should show "X-Charge Open Integration" above the version number. If it just shows "X-Charge", then it's probably not the Open Integration version.

General X-Charge Setup (XpressLink method)

Here are the steps for setting up for use with X-Charge XpressLink.

Network users: Note that settings are workstation-specific, so this must be done on each computer. However if you set it up and get it working on the Master computer first, then on the others you can use the "Copy settings from the Master workstation" button to auto-copy all of the applicable settings in one step. Then the only things you may need to adjust are the X-Charge Executable path and the Result File Path.

1. In Campground Master, go to Maintenance / Credit Cards / Processing Setup, and check the "Enable..." box
2. Make sure "Processing software is installed on this computer" is selected.
3. Select "X-Charge XpressLink" for the type of processing software used.
4. Click the **XpressLink Options** button.
5. If you're using an EMV chip card reader, make sure the first option is enabled (Allow "Process" before swiping). You will also need to disable the 2nd option (Allow cards to be swiped before "Process"), and possibly also the "Allow keying in..." option for maximum security.
6. If "Allow keying in..." is checked and you're using an EMV reader, then check "Vault keyed cards before processing".
7. Check the User ID needed and Password needed boxes, and enter a valid X-Charge user ID and password. Remember that this will need to be changed here any time you change it in X-Charge (usually every 90 days).
8. Verify the X-Charge Executable file setting. This is usually "C:\Program Files\X-Charge\XCharge.exe" (or "C:\Program Files (x86)\X-Charge\XCharge.exe" in later versions of Windows), but in rare cases it may be different.
9. The Result File Path should be blank so it uses the default path (database path). If you have a specific need to change this we recommend that you contact support for details. Under **no** circumstances should it be a path shared by multiple workstations, e.g. on a network mapped drive.
10. The other options in XpressLink Options should be left as the defaults. Click Save to return to Processing Setup.
11. Click the "Debit Options" button, and set the preferences accordingly.
12. Set other options as desired in the Credit Card Processing Setup dialog (see Processing Setup Options).

Important: When using XpressLink, the X-Charge terminal window (sometimes called the X-Charge "client", or just "X-Charge") cannot be running -- otherwise it will block Campground Master's interface. If you get a time-out when trying to process cards, check to make sure that the X-Charge **Server** is running but **not** the X-Charge terminal window.

X-Charge (legacy)

IMPORTANT -- Because this method writes unencrypted card data to the hard drive momentarily, it does not meet PCI compliance regulations. This method is unsupported and should not be selected for a new install. If details are needed then refer to older versions of the software manuals.

XpressLink Options Dialog

Various XpressLink options are accessed through Maintenance / Credit Cards / Processing Setup, and clicking the "XpressLink Processing Options" button (only available if "X-Charge XpressLink" is selected as the processing software used).

Reset to Defaults -- Clicking this will reset all settings on this page to the defaults, except for critical entries like the merchant ID's, User ID, and Password.

Allow "Process" before swiping/keying in credit card -- If this option is enabled, then you can click the Process button without entering card information or swiping a credit card first. This is more secure in general, however this also means that Campground Master will never see the full card number or expiration date. That information is stored in X-Charge. You will still be able to process additional charges to the same card later (an X-Charge ID is used to reference the card information).

Allow swiping credit card before "Process" -- This is enabled by default for normal operation. If you disable this, then swiping a card in Campground Master directly will show an error message, instead of attempting to process it (because this causes an error if you're using the Secure version of X-Charge). This forces you to click the "Process Card" button before swiping the card into X-Charge directly. This does not prevent entering a card number manually.

Allow keying in credit card before "Process" -- This is enabled by default for normal operation. If you disable this, then typing in a card number in Campground Master directly will show an error message, instead of attempting to process it. This forces you to click the "Process Card" button before typing the card into X-Charge directly. This does not prevent swiping a card.

'Vault' keyed cards before processing -- If you're using an EMV/chip terminal instead of a simple mag swipe, then this must be checked if you're allowing keyed cards before "Process". X-Charge won't accept cards directly from Campground Master if configured for an EMV reader, but as a workaround it can vault the card and then use the vaulted card immediately.

Note: If both the "Allow swiping" and "Allow keying" options are disabled, the credit card entry fields will always be disabled (but will still show previous card information if those retrieval options are enabled). Thus the "Process Card" button must be used.

X-Charge Executable file -- See step 3 above in the setup -- this needs to point to the XCharge.exe file on the local computer.

User ID needed / Password ID needed -- For the newer versions, these must both be checked and the ID and password entered. Be sure that you're not still using the default login. Also note that this needs to be set (and updated periodically) on every workstation.

***** Reminder** -- X-Charge may require you to change the password for the User login every 90 days. This means you also need to go into Campground Master and update the password.

Merchant ID's -- These should be left blank, unless you've specifically set up separate merchant accounts with CAM Commerce for swiped vs. non-swiped cards. Note that if ID's are entered in X-Charge's own setup, these ID's will be ignored.

Result File Path -- This should normally be left blank, to use the same path as the local database. If you change it to anything else, make sure it's on the local hard drive for this workstation, and unique for this database (if you have any need to load more than one database at a time on this workstation).

***** WARNING** -- If the Result File Path for two instances of Campground Master is the same, transactions can become interchanged if charges are attempted simultaneously. For this reason, a network path is not allowed here.

Other settings -- The remainder of the settings on this dialog should only be changed if directed by support staff. Changing them may keep the processing from functioning properly!

Using the X-Charge Secure Vault for storing credit cards -- If you don't want Campground Master to store cards at all, then you can use X-Charge's secure "vault" for storing the card for guarantees and transactions.

This is fully secure and does not store the card on your computer. You will still be able to see the last 4 digits of the card and expiration date, but will not be able to see the full card information. The card can then be used for a payment transactions if needed, depending on your Credit Card Security Settings. In order to use this function, you also must select the "Never save credit card numbers" option in Credit Card Security Setup, and be using the XpressLink interface for credit card processing. You will then have a button on the Guarantee dialog to Enter card information to secure vault. Click that button and X-Charge will prompt for the card information. You can also add or remove the secure vault information from the Edit Guarantee dialog (on Customer Details or Reservation Details, click the "..." button next to the Guarantee information). Payments will work as usual, with the exception that the full card number will no longer be stored with the transaction -- only the masked card number, expiration date, and the secure vault ID so it can be used for further transactions.

X-Charge (XpressLink) Troubleshooting

Here are some common error messages when processing with X-Charge, and their cause or remedy:

X-Charge requiring log-in - If it asks you for a login every time you process a card, then you need to enter the User ID and Password (and check the "needed" boxes) in the XpressLink settings.

"Invalid card" when swiping a card rather than typing it in -- this usually indicates that you have the "Secure" version of X-Charge installed. They must install the "Open Integration" version, not the Secure version.

"Internal error executing X-Charge" -- Either X-Charge has not been installed on this computer, or the X-Charge terminal is already running (outside of Campground Master), or the path to X-Charge is not correct in the XpressLink settings.

EMV Field Selections

When using either X-Charge XpressLink or Cayan's Genius platform for processing EMV cards (chip cards), many additional "EMV fields" are provided in the results of the transactions. The dialog for EMV Field Selection allows you to select which ones of these will appear on receipts, if available. Access these selections by clicking the EMV fields on receipts button through either the XpressLink Settings or the MerchantWare Settings dialogs.

Some of these fields are required, and some are not strictly required but recommended. By default, all of the recommended ones are selected. Change the selections as desired by Shift-Clicking to select or deselect each item.

Debit Options

These functions are accessed through Maintenance / Credit Cards / Processing Setup, and clicking the "Debit Options" button (only available if "X-Charge XpressLink" is selected as the processing software used).

Enable Debit Card processing -- This must be enabled to allow "Processing" of debit cards as debit transactions (e.g. with PIN # entry). If this is not checked, you can still process debit cards as credit cards (no PIN entry, with higher transaction fees).

Allow cash back from debit cards -- This enabled the "Cash Back" entry on the Enter Payment dialog, so cash-back transactions can be processed for debit cards. Note that this can be enabled even if not processing cards through Campground Master -- this allows entry of cash back for accounting purposes, presuming that you're doing the appropriate processing outside of Campground Master. Also note that there is an Access Level setting that can be set to limit cash-back options to certain operators.

Limit dollar amount of cash back -- If an amount is entered here, then the Cash Back amount cannot be larger than this amount. This assumes that debit cards are processed through Campground Master -- if not, then the limit is ignored. If no value is entered here, then there is no limit.

Basic Setup - Cayan MerchantWARE Web

MerchantWare Web services can be used with your own merchant service account, or you can use Cayan's own merchant services. Be sure to contact Cayan for a quote to see which is a better deal for you. (Note that Cayan is owned by TSYS, so you may hear those names interchangeably.)

Using the MerchantWare gateway with 3rd party merchant services

If you're using MerchantWare Web services as only a gateway to your own merchant service, then you will first need to contact Cayan to get a gateway account set up (see our web site for current contact information). Then you will need to put your merchant service agent in touch with Cayan (ask Cayan how to do that), so they can configure the gateway with your merchant account information. Campground Master is not involved in that part -- do **not** have your merchant services agent contact us directly, we cannot help them in any way. The only thing you need for Campground Master is the gateway account credentials (Name, Site ID, and Key). The rest of the setup is explained below.

Using the "Genius" terminal -- EMV/chip cards, Debit, etc.

Cayan has a special terminal to allow various advanced forms of processing, including EMV/chip cards, Debit/PIN cards, and even ApplePay. You will need to contact Cayan and get the terminal equipment from them. Once this is set up, just enable it in Campground Master and enter its IP address and it will integrate seamlessly.

- Note: The Genius terminal requires a hardwired Ethernet connection to your LAN (router), so if the only network connection at the POS location is WiFi, it will not work. It also requires access to the internet (as does Campground Master).
- IMPORTANT: You cannot process cards on one terminal from multiple workstations at the same time -- attempting to do so will cause errors and possibly incorrect approvals. While you can share a terminal with multiple workstations, it is up to the operators to make sure that the terminal is not currently processing a transaction from another workstation before starting another one.

MerchantWare setup in Campground Master

Here are the steps for setting it up for MerchantWare, for use with Cayan's merchant services or with another merchant service.

Network users: [Note that settings are workstation-specific, so this must be done on each computer.](#) However if you set it up and get it working on the Master computer first, then you can use the "Copy settings from the Master workstation" button on each client to auto-copy all of the applicable settings in one step. Then the only thing you may need to adjust is the Genius terminal IP address (each terminal has a unique address).

1. In Campground Master, go to Maintenance / Credit Cards / Processing Setup, and check the "Enable..." box
2. Select "Cayan MerchantWARE Web" for the type of Processing Software Used.
3. Click the **MerchantWARE Settings** button, and enter the 3 MerchantWare Credentials values -- the Name, Site ID, and Key given to you by Cayan.
4. To use the new Genius services (Genius "CED" terminal and/or Transport.Web as backup), check "Use Genius protocol". This allows you to process a payment without entering the card information in Campground Master (click the "Process" button before entering a card number), which is more secure.
5. If you have the physical Genius terminal, check the "Genius terminal present" box and enter the IP address of the terminal to be used with this workstation.

6. The other options here may be left as the defaults (see settings details below for details). Click "Save" to return to Processing Setup.
7. Make sure "AVS enabled" and "CVV2/CVC enabled" are both selected, since these are required for MerchantWare.
8. Set other options as desired in the Credit Card Processing Setup dialog (see Processing Setup Options).

For networked setups, simply repeat the steps above on each computer, or use the "Copy settings from the Master workstation" button and then set your specific Genius terminal IP address (if applicable).

Note: Each computer must have access to the Internet.

Additional Transaction Categories:

When processing payments through Genius, additional features may be available that allow the customer to add a Tip, Surcharge, or Donation through the terminal (contact Cayan for details about enabling and using these). If this happens, Campground Master will add a corresponding Charge transaction, and will expect an appropriate Transaction Category to be available. Therefore you must add Transaction Categories (see Maintenance / Pick Lists) with the exact Selection Names of "Tip", "Surcharge", and "Donation" as needed. Otherwise it will use the first category in the pick list, which will be confusing to you and the customer.

MerchantWare Settings Dialog

Various MerchantWare options are accessed through Maintenance / Credit Cards / Processing Setup, and clicking the "MerchantWARE Settings" button (only available if "Cayan MerchantWare Web" is selected as the processing software used).

Name -- Set to the Name given to you by Merchant Warehouse. It must match exactly.

Site ID-- Set to the Site ID given to you by Merchant Warehouse. It must match exactly.

Key -- Set to the Key given to you by Merchant Warehouse. It must match exactly.

Use Genius Protocol -- Check this to use the newer Genius protocol, including a Genius terminal and/or Transport.Web secure web page entry of credit card information.

Genius CED terminal present -- Check this box if you're using a Genius CED (Customer Entry Device) terminal at this workstation.

Disable direct credit card entry on Enter Payment dialog -- Check this if you want to prevent keying and swiping cards directly in Campground Master. This increases security by keeping Campground Master out of "scope" for PCI compliance (unless you enter cards in the Guarantee Info). This only applies if you use Genius protocol, since without Genius you must enter or swipe cards in Campground Master to process them.

Genius terminal IP address -- Set this to the IP address of the terminal that will be used with this computer. If you didn't make a note of it when setting up the terminal, see below. It should be set to a "static" IP address so it won't change if your router loses power (the directions that came with your terminal explain how to do this). Also, here is a procedure for finding the IP address, but we can't guarantee that it's correct for all terminals (contact Cayan for details if this doesn't work):

1. From the Idle Screen press "0 0 0" (zero-zero-zero) on the key pad.
2. Using the keypad enter your Genius CED password (9416557).
3. Press the Green enter button on the keypad.
4. "IP Address" is the first display setting.
5. Press the Red cancel button on the key pad to return to the idle screen.

Stage connect/response timeouts -- The number of seconds it should wait for successful connection and for getting a response from the MerchantWare server when requesting a transaction key for a Genius transaction. Defaults are 10 and 30 seconds, respectively.

Terminal connect/response timeouts -- The number of seconds it should wait for successful connection and for getting a response from the Genius terminal device. Defaults are 10 and 180 seconds, respectively. Note that the response timeout must be large enough to allow for the customer to decide what to do, get through all of the prompts, sign, etc..

Other settings -- The remainder of the settings on this dialog should only be changed if directed by support staff. Changing them may keep the processing from functioning properly! In case they accidentally get changed, here are the correct defaults (as of the time of this publication):

Endpoint domain:	transport.merchantware.net
Port:	443
Endpoint path:	v4/transportService.asmx
Namespace:	http://transport.merchantware.net/v4

MerchantWARE Troubleshooting

Here are some common error messages when processing with MerchantWare, and their cause or remedy:

Invalid Credentials (or similar message indicating an unknown user, customer, or merchant) -- double-check the Merchant Name, Merchant Site ID and Merchant Key fields and make sure they match what you were given.

Any 4-digit error code, like **code 1007** -- These error codes come from Merchant Warehouse's processor, so you need to contact them to find out what it means.

Refunds not processed ("missing reference") -- Contact Merchant Warehouse and have them set your account to allow returns without the original reference.

Basic Setup - MCPS (Merchants' Choice)

Here are the steps for setting up for use with T-Gate Web Services, for use with MCPS (Merchants' Choice Payment Solutions) merchant services. You may also hear the term "PaySafe" in reference to this service.

Network users: [Note that settings are workstation-specific, so this must be done on each computer.](#) However if you set it up and get it working on the Master computer first, then on the others you can use the "Copy settings from the Master workstation" button to auto-copy all of the applicable settings in one step.

1. In Campground Master, go to Maintenance / Credit Cards / Processing Setup, and check the "Enable..." box
2. Make sure "Processing software is installed on this computer" is selected.
3. Select "MCPS / T-Gate Web Service" for the type of Processing Software Used.
4. Click the **MCPS / T-Gate Settings** button, and enter the User Name and Password given to you by MCPS. The other options here should be left as the defaults. Click Save to return to Processing Setup.
5. Make sure "AVS enabled" and "CVV2/CVC enabled" are both selected, since these are required for MCPS.
6. Set other options as desired in the Credit Card Processing Setup dialog (see Processing Setup Options).

MCPS (T-Gate) Settings Dialog

Various MCPS options are accessed through Maintenance / Credit Cards / Processing Setup, and clicking the "MCPS Settings" button (only available if "MCPS / T-Gate Web Service" is selected as the processing software used).

Support is provided for using a separate account for "swiped" transactions (card present and swiped in a mag stripe reader) vs. keyed-in transactions (card not present, also known as a "MOTO" account). If you only use a single account for both types of transactions, then enter the same account user/password information in both sets of fields.

Account to use for swiped cards -- Set the User Name and Password given to you by Merchants' Choice for card-present transactions. It must match exactly.

Account to use for keyed cards -- Set the User Name and Password given to you by Merchants' Choice for card-not-present transactions. It must match exactly.

Other settings -- The remainder of the settings on this dialog should only be changed if directed by support staff. Changing them may keep the processing from functioning properly!

In case they accidentally get changed, here are the correct defaults (as of the time of this publication):

Endpoint domain:	gateway.itstgate.com
Port:	443
Endpoint path:	/SmartPayments/transact.aspx
Namespace:	http://TPISoft.com/SmartPayments

MCPS Troubleshooting

Here are some common error messages when processing with MCPS, and their cause or remedy:

Refunds not processed (missing reference or PNRRef) -- As of May 1st, 2019, refunds require the previous transaction reference. Make sure you're running Campground Master version 10.0 **rev.f** (or later) to get this functionality. Previous versions did not include the reference so will not be able to process refunds. It's also necessary to have the previous processed credit card payment transaction as the most recent credit card transaction in the list of transactions you're able to view (e.g. in that same Reservation Transactions or POS Sale dialog), so that it has a credit card payment transaction to refer to.

"Object reference not set to an instance of an object" -- This is a general error, but is usually because the User Name and Password have not been entered yet for MCPS (see above). It may also be due to incorrect settings for the Endpoint and Namespace (the things mentioned above that you shouldn't change), or it could also be a temporary problem at their servers.

"Serv not allowed" when swiping a card (keyed cards work) -- This usually means that your merchant account is set up as a "MOTO" (mail/phone only) so it won't accept swiped cards ("card present" transactions). Get MCPS to change your account to "Retail".

PCCharge

While Campground Master will interface with PC Charge to avoid breaking existing installations, we can no longer recommend this software as an option because it's no longer supported by the manufacturer and will not run on Windows 8 and later. For setup and troubleshooting details, please refer to previous versions of the documentation, e.g. version 9.0, which can be found on our web site

ICVerify

While Campground Master will interface with IC Verify, we can no longer recommend this software as an option because it's extremely difficult to implement the newer versions (e.g. 4.2). While the last working functionality is present in Campground Master for legacy users, we officially designate IC Verify as "not supported" and will not help users with integration. See Newsletter #40 on our web site for more details if you attempt to integrate IC Verify 4.1 or 4.2. For setup details, please refer to previous versions of the documentation, e.g. version 6.0, which can be found on our web site

Credit Card Security Setup

This dialog is accessed through Maintenance / Credit Cards / Security Setup. The options here allow some flexibility in the way credit card information is handled by the program.

These options apply whether you process credit cards through Campground Master or not, as long as you're entering credit card information in the designated fields for Guarantee Information or for Payments and Deposits. If you put credit cards in other places, such as Notes fields, then that information is not secure at all regardless of these options.

Important: For maximum security, all options here should be checked (enabled). While disabling some options can make it more convenient for the user, be aware that any disabled options reduce the security of your customers' credit card information!

Note: Also see Maintenance / Park Setup / Access Levels to restrict operator access for viewing credit card numbers.

Remove Guarantee info... -- These three options allow you to configure how long the "Guarantee" credit card information is kept. Besides keeping operators from viewing it, this also means that it won't be accidentally used for later transactions by the customer (assuming this is enabled at all, see below).

Remove credit card information from all Transactions... -- These two options allow you to automatically remove any card information from a Reservation's Transactions once they check out (or if the Reservation is canceled). Be aware that this will also remove any stored "transaction references" used for credit card processing, so it will be impossible to add additional charges or give refunds without providing the credit card information again. It only retains the "Approval code", if present from previous processing, so you can tell that it was actually processed through Campground Master.

Don't retrieve previous credit card information for new transactions and guarantee info -- If this is disabled (unchecked), then it will check previous transactions or guarantees for credit card information when guaranteeing or adding a payment or deposit to an existing reservation (or customer). If a previous credit card is found, that card information will be filled in automatically (but can be changed using the "Re-enter / Re-swipe" button). Note that this retrieved data will not have the swipe data (due to PCI compliance), so it will be more expensive to process the charge than if you re-swipe the card. Therefore you may want to keep this option checked so you're always forced to swipe the card again and will get the best processing rate.

Limit retrieval of previous card information to the current reservation's transactions -- If you allow previous card retrieval at all (by disabling the previous option), it's a good idea to limit it to the current reservation instead of looking at previous reservations. Besides security reasons, this keeps you from accidentally charging to an old card from a previous stay.

Note: As of version 10.0 rev.g, the "Don't retrieve" settings above are ignored for Refund transactions, since the previous card information is required in order to do refunds.

Never save credit card numbers --If this is set, then the card number entered for a Payment, Deposit, or Refund will only be saved as a masked number after processing. If you don't process cards through Campground Master, then credit card entry fields for transactions and guarantee information will be disabled.

Note that if you use X-Charge XpressLink or Cayan/MerchantWare Web for processing cards, then a secure ID is saved for the credit card so that you can still use the card again for future transactions even though Campground Master never saves the complete card number.

Note that a transaction ID code is saved even if the card number is not saved, since it's required for refunds.

Credit Card History / Security Cleanup

There are several functions to clean up old credit card information. You can run any or all of them at any time, depending on what information you want to remove.

Note: This assumes you've entered credit card information in the designated fields for Guarantee Information or for Payments and Deposits. If you put credit cards in other places, such as Notes fields, then that information is not removed automatically.

The first two functions, removing swipe data and CVC (security) codes from ALL transactions, are required to be run once for any older database to meet PCI compliance. These functions sweep all of the security codes and swipe information from the entire database, but leave the other card information intact.

PCI Compliance note: Refer to the PA-DSS Implementation Guide (see the *Introduction* chapter) for important details about proper security procedures.

If you want to completely remove credit card information from past customers, etc. (including the card numbers, expiration dates, etc.), there are several functions that will do that. You can select which transactions or guarantee information is cleaned of card information, or you can choose the option to clean all credit card information from the entire system. Note that the options for removing "old" or "past" information won't remove it from the Guarantee information of future reservations (presumably you still need that), or from transactions of future or current reservations (since you may need to process a void, credit, or additional charge).

Finally, while it's not a strong security risk if you leave expired cards in the system, you can clean out all expired card information if you prefer. Expired cards won't be re-used by accident anyway, so this is simply a minimal clean-up operation. Keep in mind of course that this will still remove some "history", in terms of what card was used for past transactions.

Important: These functions can result in a large number of data changes, potentially causing delays if you're networked, etc., especially if you have never done these before or only do them on rare occasions. At the very least, close this dialog after each operation if it shows that more than 100 records were cleaned up, to allow things to be synchronized and log files saved.

Remove a Customer's Credit Card Information

This function is primarily used if a customer requests that you completely remove his card information. Go to this function under Maintenance / Credit Cards, which will first ask you to Find the customer. Once you've selected the appropriate customer and you confirm it, all credit card information will be removed from any reservations this customer has ever had in the system, and of course from the guarantee information also.

Note: This assumes you've entered credit card information in the designated fields for Guarantee Information or for Payments and Deposits. If you put credit cards in other places, such as Notes fields, then that information is not removed automatically.

Online Setup

The menu under Maintenance / Online Reservations contains functions related to online (web) reservations setup and operations. However, the Online Reservations functionality is covered in a separate chapter, prior to Maintenance.

E-mail Setup

Overview

This section describes setup functions related to E-mail. SMTP Setup must be done first to enable the E-mail functionality, then you will be able to send E-mail confirmations, receipts, etc, and even do bulk E-mailings of notices, invoices and other forms.

SMTP Setup

To enable E-mail confirmations, the appropriate settings need to be configured first -- go to [Maintenance / E-mail Setup / SMTP Setup](#). This enables sending E-mail messages from within Campground Master. (SMTP stands for "Simple Mail Transfer Protocol", which is a standard E-mail system used on the Internet.) These settings are similar to configuring most E-mail applications in Windows, like Mozilla Thunderbird and Microsoft Outlook.

To use the E-mail functions like sending confirmation E-mails, Campground Master must be able to access an SMTP mail server via the internet. If you're not using one of the E-mail services with specific examples below, contact your provider to see if they have an SMTP server available and what the settings should be. Note that if you're using GMail or GSuite, then you can also use the "Oauth2" authentication which is more secure and avoids some of the issues with SMTP setup.

Note that another standard, "IMAP", is not currently supported.

Using the SMTP function to send E-mail

Once the SMTP configuration is done (particularly the Sender and Server information as mentioned below), then a new button will be available on the [Reservation Transactions](#) dialog to [Send E-mail Form](#) (like confirmation letters). There will also be an [Email Form](#) button on [Reservation Details](#) and [Customer Details](#), as well as right-click functions to send E-mails from the tab views, and Batch E-mailing will also be possible from the E-mail list reports for Customers and Reservations.

You can also send E-mail messages to customers using the blue "E-mail" link on Customer Details (but with SMTP configured it uses the built in E-mailing instead of opening the default E-mail program in Windows).

Global settings vs. different settings on each computer

If you're using the networking option, you'll see an option to either use global settings or use different settings on this computer. In most cases you'll want to use global settings, since each computer on a local network generally needs to be set up the same (except for possibly the bind-to IP address, which is always a local setting anyway). However if you use a computer to connect remotely, e.g. through the internet from various places, then you might need to use different settings on that computer depending on the specific internet connection (ISP) you're using at the time.

Note: Be sure to select the option to use "different" settings before making changes to the settings, so you don't inadvertently change the global settings for everyone else!

Sender (defaults) Settings

Your name & E-mail address can be entered in the Sender section. The Name and E-mail entered here are used for both the "From" and the "Reply-To" for every E-mail you send. Optionally you can check the options to have it use the Park's Name and Park's E-mail address, as defined for the Park (or Parks) through Park Setup. This is useful if you have more than one park set up in the database, and want to use a different Reply address in confirmations depending on which park it's for. (If an E-mail is sent to a customer without reference to a reservation, the park specified as the Park shown on non-reservation receipts will be used, and that setting is specific to each workstation.) Note that if you do check these options, the name and E-mail addresses entered here will be ignored when appropriate park information is available. However you should still fill in a default Name and E-mail address here, in case an the Park record doesn't have the E-mail field filled in.

Important: Many SMTP servers require these to be in the same "domain" as the SMTP host you're using. For instance if you're using SMTP through your web host and your web site is myrvpark.com, then you might need to use an E-mail address that has @myrvpark.com in it. Likewise, if using GMail use your username@gmail.com, etc.

If you want to keep a copy of all E-mails sent, the best way is to fill in BCC all mail to with your E-mail address. This will blind-copy each E-mail to yourself (or any address desired. If you want to enter multiple E-mail addresses for the BCC, use the semicolon character (;) between each address to separate them.

Server Settings -- using GMail OAUTH2 Authentication

As of version 11.0, support has been added to send mail using OAuth2 through GMail. While this is much simpler as far as the settings required in Campground Master, and allows you to keep your GMail account more secure, it does require an "Authentication" process to start with. This is generally a "one time" process and only takes a minute or less, however it will need to be repeated occasionally, if you change passwords for instance.

To use this method, first make sure your GMail E-mail address is being used as the E-mail address in the Sender section (see above). Then in the Server section, select "GMail OAuth2" for the Authentication Method. Most other settings will be hidden since they aren't needed.

Next, click the Request OAuth Access button to start the authorization process. A window will appear with the instructions (as shown below) -- click "Begin!" to start.

Note: If you get a pop-up from Windows Defender or other firewall, make sure you tell it to allow Campground Master for **both** Private and Public networks.

Your web browser will open and prompt you for authorization. You must:

- 1. Log into your GMail account (or select the account to use).
.... If you see 'This app isn't verified', click "Advanced" and then click "Go to Campground Master (unsafe)"
- 2. Click "Allow" on the 'Grant Campground Master Permissions' page
- 3. Click "Allow" again on the 'Confirm your choices' page.

Important: You will have to complete these steps within 60 seconds of when you click 'Begin!'. If you get an error 'Unable to connect' after those steps, then it took too long. Close your browser, go back to Campground Master, and start again. If necessary, you can increase this timeout on the SMTP Setup page.

If you decide not to continue before it's done, you can click the Cancel button to tell Campground Master to stop waiting for authorization -- otherwise it will wait until the timeout is finished and show an error.

Once you complete the steps, the window above will close and you will get a confirmation that Campground Master has been authorized.

Important -- you may also get an E-mail from GMail indicating that a new application or device was authorized. You should follow the link in the E-mail to "check the activity" and confirm that it was you who did it, to prevent Google from flagging it as a security issue.

Request OAuth Access button -- this is used for initial authorization (shown above), or any time you want to change which GMail account to use. You can also use it again any time, it doesn't hurt anything to re-authorize.

Refresh OAuth Token button -- this is usually not necessary, since it will be refreshed automatically whenever needed to send E-mail. However if you have trouble sending E-mail, then you could try this to see what error information is being returned.

Server Settings -- using an SMTP Server (without GMail OAuth2)

The Host name/address is the name of server you'll use for sending mail. If not using one of the common mail services like Yahoo or GMail illustrated below, this is usually "mail" or "smtp" followed by your ISP or web host domain name. A couple examples are below:

smtp.myrvpark.com (for instance if you have your own domain name for your web site)
mail.myisp.net (for instance if you do E-mail through an ISP like Earthlink)

If you have any questions about the proper settings to use in SMTP Setup, please contact your internet provider, web host, or whatever service you're using to send mail.

Most SMTP servers now use port number 465 with SSL (or port 587 with TLS), and use Automatic authentication. However some web hosts and other E-mail providers used other ports and options.

The "Automatic" setting for Authentication Method should work in most cases, with the username and password filled in. There are some cases where it cannot be automatically detected, though, so you can set it to one of several manual settings. Also, the "Automatic" setting will not work if "POP3 before SMTP" authentication is required.

POP3 before SMTP authentication -- Some SMTP servers, typically ones used by web hosting services, may not have a login on the SMTP itself but may require you to read your E-mail (through the web host's POP3 server) before you can send mail through their SMTP server, with a time-out. If this is the case for your SMTP host, select the "POP3 before SMTP" authentication method and provide the login, host, and port for the POP3 server.

Note that the Return Receipt option simply sets a flag in the E-mail requesting a return receipt when the E-mail is opened, but this does not guarantee anything since many E-mail programs don't support return receipts.

You can use the **Test** button on this Setup dialog to test your settings by sending an E-mail to yourself. You can also change the E-mail to test sending to someone else, which is a good idea since in some cases you will be able to send mail to yourself but not someone at a different domain, due to insecure server settings.

Gmail Settings example -- when NOT using OAuth2 as described above

If you use Gmail (Google mail) and don't wish to use the OAuth2 authentication, use the settings below. Reminder -- you can only use the Gmail SMTP host if your E-mail address (for the From & Reply-to) is also an @gmail.com address.

Host Name/Address: **smtp.gmail.com**
Port Number: **465**
Use SSL: **Checked**
Use TLS: **Unchecked**
Authentication method: **Automatic**
Username : **(your Gmail login)**
Password : **(your Gmail password)**

Important: You may also have to go into your Gmail account settings and enable access from 3rd party programs -- Google has a new feature that blocks SMTP for a lot of people until you change a security option. To solve this:

1. Go to <https://myaccount.google.com/>
2. Sign in if needed.
3. Click on 'Signing in to Google' or 'Apps with account access'
4. Toward the bottom you will find a box/section 'Allow less secure apps'. Make sure it's "on" (click to the right end of the slider, it should turn blue).

Also Important: Also note that Gmail will not allow SMTP access if you have "2-step verification" enabled for your account without using an "app password". So one option is to make sure this is **not** enabled for your Gmail account. However if you require 2-step verification, then you need to set up an App Password to use with Campground Master. Use this procedure (subject to change by Google):

1. Go to your Google Account: <https://myaccount.google.com/>
2. On the left navigation panel, choose Security.
3. On the "Signing in to Google" panel, choose App Passwords. If you don't see this option, then one or more of these may be the reason:
 - 2-Step Verification is not set up for your account.
 - 2-Step Verification is set up for security keys only.
 - Your account is through work, school, or other organization.
 - You've turned on Advanced Protection for your account.
4. At the bottom, choose Select app and choose the app you're using.
5. Choose Select device and choose the device you're using.
6. Choose Generate.
7. Follow the instructions to enter the App Password. The App Password is the 16-character code in the yellow bar on your device.
8. Choose Done.

Now use that App Password as the password in your SMTP setup.

Yahoo Settings example

Yahoo settings are shown below. Note that you must use your Yahoo E-mail address in the From/Reply To address or else it may not work.

Host Name/Address: **smtp.mail.yahoo.com**
Port Number: **465**
Use SSL: **Checked**
Use TLS: **Unchecked**
Authentication method: **Automatic**

Username : **(your Yahoo login)**
Password : **(your Yahoo password)**

Reminder -- you can only use the yahoo SMTP host if your E-mail address (for the From & Reply-to) is also an **@yahoo.com** address.

Note: You may also have to go into your yahoo account settings and enable access from 3rd party programs -- Yahoo has a new feature that blocks SMTP until you change a security option. To solve this:

1. Sign in if needed.
2. Go to "Account Security Settings" (or use this link): <https://login.yahoo.com/account/security>
3. Toward the bottom you will find a setting 'Allow apps that use less secure sign in'. Make sure it's "on" (click to the right end of the slider, it should turn blue). If you don't see this option, then you probably have your Yahoo account set up to sign in with a "Yahoo Account key" instead of a password. In this case, additional steps are required to allow using their SMTP server from Campground Master:
 4. Click "Generate App Password" (or "Manage App Passwords") to add a new app password
 5. Select "Other App" as the application type
 6. Enter "Campground Master" for the name
 7. Copy the password it gives you into the Password field in SMTP setup

Hotmail Settings example

If you use Hotmail, the settings should be:

Host Name/Address: **smtp.live.com**
Port Number: **587**
Use SSL: **Unchecked**
Use TLS: **Checked**
Authentication method: **Automatic**
Username : **(your Hotmail login)**
Password : **(your Hotmail password)**

Reminder -- you can only use the Hotmail SMTP host if your E-mail address (for the From & Reply-to) is also an **@hotmail.com** or **@live.com** address.

Outlook Settings example

If you use Outlook.com, the settings should be:

Host Name/Address: **smtp-mail.outlook.com**
Port Number: **587**
Use SSL: **Unchecked**
Use TLS: **Checked**
Authentication method: **Automatic**
Username : **(your Hotmail login)**
Password : **(your Hotmail password)**

Reminder -- you can only use the Outlook SMTP host if your E-mail address (for the From & Reply-to) is also an **@outlook.com** address.

America Online Settings example

If you use America Online for your Internet access, there is an SMTP server available for you to use. Reminder -- you can only use the AOL SMTP host if your E-mail address (for the From & Reply-to) is also an **@aol.com** address. The following Server settings should be used:

Host Name/Address: **smtp.aol.com**
Port Number: **587**
Use SSL: **Unchecked**
Use TLS: **Checked**
Authentication method: **Automatic**
Username : **(your AOL screen name)**
Password : **(your AOL password)**

Also, the Sender E-mail address should be in the Internet format (your AOL screen name followed by "@aol.com"), such as: **myscreename@aol.com**. Note that any spaces in your screen name must be removed, so "My Screen Name" would become MyScreenName@aol.com.

Send E-mail (Preview)

This dialog shows the E-mail you're about to send, and allows you to modify the various details beforehand. It's similar to the Email functionality of most E-mail programs. It will be invoked from various places:

- From Customer Details, by clicking the blue "E-mail" link next to the E-mail address (opens a blank E-mail to send your own message)
- From Transactions, after going through "E-mail Confirmation" or "Send E-mail Form" and clicking OK to send, if Preview is selected.
- From Reservation Details or Customer Details, after going through "E-mail Form", and clicking OK to send, if Preview is selected.
- From any of the various Batch E-mailing functions, if Preview is selected.

Of course before this can appear, you will have to perform the SMTP setup so Campground Master can send E-mail (as covered in the previous section).

To -- this is the E-mail address it will be sent to. This should already be filled in with the customer's E-mail address. If you want to send to multiple addresses, you can either add them here, using the semicolon (;) separating them, or use the CC or BCC fields.

Name -- This is the recipient's name of course.

CC -- Add additional E-mail addresses here to "carbon copy".

BCC -- Add additional E-mail addresses here to "blind carbon copy". Note that any BCC E-mail address(es) already configured in SMTP Setup will not appear here, and cannot be removed from here, but the message will still be BCC'ed to them. Any addresses you add here get a copy in addition to those already configured in SMTP Setup.

Attachments -- File attachments will be listed here. Use the browse button to select attachment(s). For multiple files, the "pipe" character (|) must be used. Each file must have the full path.

Subject -- Subject line for the E-mail.

Message -- The body of the E-mail. Only plain text will be shown. If an HTML E-mail form was used, you will see the raw HTML coding here -- be careful not to modify it in a way that would cause HTML errors.

Batch E-mailing options

There are a few options you can adjust for when sending multiple E-mails from the E-mail list reports (also known as "batch e-mailing" -- we prefer not to use the term "mass E-mail" since this isn't to be used for spam). These options are found in [Maintenance / E-mail Setup / Batch E-mail options](#).

"Send in groups of..." and "Pause for..." settings

These are used to define the size of the "fast" batches and how long to pause between each group. For instance, it may send 10 at a time, with a 5-second pause between them. This is partly to allow you a chance to cancel during sending (during each pause period), but is also helpful in keeping your E-mail provider from flagging you as sending spam. The recommended settings are groups of 10, with a 5-second pause. While it may be tempting to use a large group size and/or small pause to make it go fast, be very careful with this as your E-mail provider may not be happy with it, possibly causing cancellation of E-mail service.

Skip Auto-BCC'ing

If you have a BCC (blind carbon copy) set up in the SMTP settings so that you get a copy of every E-mail sent, that would normally apply to batches also. If you don't need to get a copy of every one, then you can set the Skip option(s) so that the BCC is ignored when sending more than one E-mail at a time. Also keep in mind the Audit Trail reporting (below), which may or may not have full copies of the E-mails as well.

There are separate settings for "with transactions" vs "without transactions", so for instance you can skip the BCC when there are no transactions (e.g. general notices) but still get copies of every customer's invoice with transactions.

Audit trail includes full E-mail text

Normally (for single E-mails), the Audit Trail includes a full copy of every E-mail sent. However this isn't recommended when sending batches due to the amount of space it would take, so these options are off by default. If you really want it turned on you can do so, but for instance if you send a notice to 2000 seasonal customers, and each one is 3000 characters, that's 6 Meg instantly added to your database size (not to mention the synchronization time it would take for networked systems). This affects how long it takes each time you save the database, start the program, etc., so it's worthwhile keeping it to a minimum.

Also keep in mind that with these turned off, the Audit Trail will still show each E-mail sent but will simply include the Form name for reference (e.g. "E-mail receipt"). Also, if it's a free-form message (entered at the time of sending rather than a pre-defined Form), then the full text will be shown in the Audit Trail's "Preparing to send" entry for the batch.

General warning about batch-sending E-mails

Any time you send large quantities of E-mail, you risk being labeled as a "spammer" by your customers, your internet service provider, your E-mail provider (e.g. G-Mail), or any number of E-mail black-list organizations. Therefore we caution you to be very conservative with E-mail sending. Do your due diligence in finding out what restrictions your providers may have and study the general best practices discussed on the Internet. Limit E-mail sending to only recent customers who have a legitimate need to know about what you're sending them. We cannot be responsible for any issues that may arise from sending mass E-mails or for the content of those E-mails.

Confirmation E-mail Text & Options

You can configure the E-mail confirmation letter text similar to the options for printed confirmation letters. This configuration is done through [Maintenance](#) / [E-mail Setup](#).

The first option enables a [preview](#) of the confirmation E-mail before sending. This is recommended, especially if you might want to add special notes to the message for each customer. It will open an E-mail window where you can edit the text or subject of the E-mail as needed before sending. Note that this may be overridden when selecting a specific form for E-mailing, when multiple forms are defined, but will be used as a default for confirmations.

The [Subject](#) for the E-mails should be something fairly generic, but also something that should catch the customer's attention. For instance, include the name of your campground so they know what it's about. This is only used as a default -- if you edit the Form then you can change the subject there (and have multiple Forms with different subjects), in which case this setting will be ignored.

The [Letter text](#) may be any length. You can also add line breaks, blank lines, etc. using the Enter key just like typing a letter. The [Bottom text](#) can also be any length.

If you have the "Site_Confirmation_Text" field enabled for sites (see Data Field Definitions), you can have special bottom text appear for individual sites. The Bottom Text from this dialog will be used as the default for sites without special text entered, but you can override it by entering Confirmation Text in Site Details.

[Summary Options](#) -- these are used for the E-mail confirmations that don't include a complete Transaction table. There is an option to show only the deposit paid and balance due on the confirmation letters, in case you don't want to show details.

In addition, you have the option to show the [Reservation Type](#) and how many [adults](#) and [children](#) the rate is based on, and include [pets](#), [vehicles](#), and [trailers](#).

[Show "Check In/Out" instead of "First/Last Night"](#) -- this option will show the dates as the actual dates of check-in and check-out (departure), rather than first and last night (the Check-In day is the same as First Night, but the Check-Out day is one day later than Last Night). This is largely a matter of preference, but can avoid some confusion by the customer. It was also an attempt to help Google interpret the dates when it decides to show an appointment card, but it doesn't always help. Note that this only affects the Confirmation letter, not E-mail receipts and invoices.

Invoice, Receipt and Statement E-mail text

You can configure the E-mail text for receipts, etc similar to the options for printed receipts. This configuration is done through [Maintenance](#) / [E-mail Setup](#). From there, select the option corresponding to the E-mail form you want to change -- E-mail Invoice, E-mail Receipt, or E-mail Statement.

The [Subject](#) for the E-mail is only used as a default -- if you edit the Forms then you can change the subject there (and have multiple Forms with different subjects), in which case this setting will be ignored.

The [Letter text](#) may be any length. You can also add line breaks, blank lines, etc. using the Enter key just like typing a letter. The [Bottom text](#) can also be any length.

E-mail Form Customization and HTML E-mail

One of the common requests is for creating or enhancing new E-mail forms, e.g. for confirmation letter variations, other types of E-mail like cancellation letters, thank-you letters, etc. There are several Sample Forms available for import that will help you get started with making your own set of E-mail forms, including several varieties of confirmation letter formats, a cancellation letter, and a thank-you letter. For details on importing the sample forms, see the Forms section under [Maintenance](#) / [Advanced Customizations](#).

What follows is technical information since this is an Advanced function -- you will need to be familiar with changing Forms definitions as well as with HTML coding.

Note that the E-mail samples with transactions have 2 versions -- "(old)" and "v9.1". Older versions only supported one compact transaction format due to the limitations of text E-mails, so those are now called "(old)". As of version 9.1, HTML E-mails are supported and in particular can be Fixed-pitch text (using the HTML tag "<pre>"), so columns will come out correctly in the transaction table.

There are some specific requirements for all E-mails, but in particular for using HTML coding in E-mails.

- Any Form to be used as an E-mail must have the Form Type set to "E-mail". This also means it will use "Character positions" for the format (in versions prior to 9.2, this had to be set manually, in addition to setting the Printer to "Text output").
- If the "Fixed Pitch Text" option is selected, it will use HTML automatically (with the entire E-mail text enclosed in a <PRE> tag before sending). This is the way E-mails with transactions are set up by default, so that columns are aligned.
- If you want something other than fixed-pitch normal text included anywhere in the E-mail, you must include the <HTML> and <BODY> tags as text elements manually to make it HTML (and then be sure to use <PRE> for the fixed-pitch sections like the transaction table).

The way Campground Master allows HTML E-mails is by recognizing the "text" output of the E-mail as an HTML document instead of plain text. While full HTML editing (and previewing) within Campground Master isn't yet possible, you can paste complete HTML source code into an E-mail text (or create a custom Form to generate the desired HTML source), and the E-mail will be sent as HTML instead of text. This means that you can send E-mails with various fonts, graphics, tables, etc. instead of the normal text-only limitations. This is a very advanced subject that requires familiarity with HTML programming, so the details of HTML coding will not be covered here.

Technically what it does when sending the E-mail is look for the E-mail body text starting with the standard <HTML> tag as the trigger for sending the E-mail as "HTML encoding" instead of "text encoding". If even one character precedes the "<HTML>" text, then it will be sent as plain text instead of HTML. (If you set the "Fixed-Pitch" option, the <HTML> is added automatically so you don't have to worry about it, and won't see it when you're editing or previewing the form.)

Trying an HTML E-mail form

Import the Sample Form "Sample Forms - E-mail confirmation with trans, logo (HTML)" to see how it's done. If you use "Save & Test Form" then you will see the HTML coding part.

Shift Report

This function only appears if Shift functionality is enabled. See Define Data Fields for details on how to enable Shift Functionality.

This function creates a special report that summarizes the activities of the current shift. If you have manager access, you can also view reports from one or more past shifts, and summarize them if desired.

Note that unlike the Transactions tab view, this report does not update dynamically. If you need to refresh it, you can click the Refresh button.

The Shift Report consists of two main sections -- Sales and Receipts. The Sales section is essentially the same as the Transactions tab view Quick Report for "Transactions by Category", showing the total charges for each category. (The main difference is that both the Selection Name and Report Heading of the transaction categories pick list are shown.)

The Receipt section contains information that would normally take 5 different reports to generate. First it reports Payments, Deposits and Refunds separately for each Payment Method you have defined. Next it shows the change in advance deposits, which is basically new deposits less deposits applied. (This is shown inverted so it offsets the Deposits received.) Finally it shows the change in the A/R balance. If all goes well, the Cash Receipt Total and the Sales Total will be the same figure.

After these sections are some additional totals:

- Deposit Amount -- this is the total amount of cash, checks, and credit card receipts (plus any other payment methods). Basically the total receipts for the shift.
- Total Advance Deposits -- this is the total unapplied deposit balance for all reservations and customers.
- Total AR Balance - this is the total A/R balance (balance due from customers, not including unapplied deposits).

Shift Change

This function only appears if Shift functionality is enabled. See Define Data Fields for details on how to enable Shift Functionality.

Each time you want to close out a shift, use this function to change the shift number. By default, it will simply increment the shift number (and this is the only option unless you have manager access). If you have manager access, you can change the number to anything you want.

There is also an option to save the current database to a separate backup file on the hard drive. The backup will be renamed to contain the shift number and date, so any number of backups can be made to the same location on the hard drive.

If you have networking enabled, this can only be done on the Master workstation. It also makes sure that no other workstations have records locked (dialogs open), and will prevent any other workstation from accessing records until the shift change is completed.

To complete the shift change, simply click the OK button. The backup will be saved if needed (and a prompt displayed showing the name of the backup), and the shift will be changed.

New Database (create a new database file)

This will close the current database and initialize the software for creating a new database. Administrator access is required to use this function, as it is usually only done once when creating the campground database and never done again.

All of the data tables will be emptied, default fields will be enabled, and default pick lists will be set up. The operator list will also be reset to having one Administrator operator, which will be logged in automatically so you can continue with setup.

You will be prompted for a name to give the database, which will also be the file name used for it. This new database file will be stored in a default location -- the exact location depends on the installation and the version of Windows, but it's usually under "Shared Documents" for Windows XP, or under "Public Documents" for later versions of Windows. From now on, that will be the default database, opened automatically when Campground Master is started (unless the "Demo" icon is used to start it).

Using New Database is not terribly dangerous because it's not easy to write this new database over your old one (you would have to select the name of the old one manually, and then it will warn you about it), but it's not something that should be done without a good reason.

Purge Old Data

This function on the Maintenance menu allows purging of transactions and reservations prior to a given date, to decrease database size and speed up reporting functions. If your computer does not have a lot of memory or your database gets very large, you may find that the functions slow down significantly after awhile. This means that the database is too large for your RAM and must be used from disk, which is thousands of times slower.

The Purge dialog consists of a "Prior-to" Date, several options that determine what type of data is purged, and a file name for doing an automatic backup of the data before purging.

The Purge operation can only be done on the Master workstation (if you're networked), and is best done with any others shut down. Afterwards, each workstation will request a full database refresh to get synced back up.

There are 3 pre-purge values maintained for each Customer to show the number of reservations, number of nights stayed, and total payments that were purged. After a purge, these values will be shown on Reservation History and Transaction History -- see below for more information. However you need to make sure that the appropriate fields are Enabled **before** you do the purge in order for it to save these values. See Maintenance / Data Field Definitions / Customer Fields and look for the 3 "Cust_Prior_..." fields.

When the Purge Old Data menu item is selected, a dialog with the various options is shown. After selecting the options, click the Purge! button to start (another warning will be shown before proceeding, with a last chance to cancel.) Be aware that the purge operation cannot be canceled once started, and cannot be undone except by reloading a backup!

Purge data prior to:

This date designates the age of the data to be purged (and what will remain "live"). It defaults to the beginning of "last year", which could actually be anywhere from one year ago to almost 2 years ago. We recommend keeping at least 1 full year of data if possible for reporting reasons. If this is not possible, you can adjust the date as needed. If you have several years of data then you can also elect to purge farther back, keeping more data "live".

One thing to note about the date is how it's used when purging -- when purging reservation transactions (and/or the reservations themselves), they will only be purged for reservations that ended prior to the given date. Therefore any reservations ending after that date will retain its complete history, even if some of the transactions happened prior to the date. However, customer transactions and unbound transactions will be purged as long as the transaction happened before that date. (Therefore a customer might have some of its transactions purged, but not others that were for a reservation ending more recently.)

Backup prior to purging:

Unless you clear out this field, a backup will be made prior to the purge function. We recommend that you **also** do a manual backup, just in case this file cannot be written for some reason. By default, it will put the backup in the same folder as your current database, and will use the same name with "backup as of yyyy-mm-dd" appended to it. Once the purge is done, you can reload that file at a later time to access the historical (purged) data. It's important to note that the backup file will be the complete database as of the time you perform the purge, rather than *just* the purged data.

IMPORTANT: If you do multiple purge operations on the same day (for instance with different options), the default file name will be used each time -- this will overwrite the original backup with the "newer" database, so the original purged data will be lost! Be sure to double-check the file name and change it if necessary to avoid overwriting an existing backup. You will be warned that the file already exists and can cancel the operation, but you need to be aware of why it's important to not overwrite it.

What will be purged

You can purge transactions, reservations, and customers.

Generally you will **not** want to purge customers, since that's your core customer database. In extreme memory conditions you may elect to purge the ones that have not been used for a long time, but otherwise it's not recommended.

Transactions primarily dictate what can be purged. Unless you select the "Extreme" option (see below), only transactions that "balance" will be purged (meaning there is a \$0.00 balance for the reservation or customer in question), and the associated reservation or customer can only be purged if all of its transactions are purged. Therefore any old reservations or customers with outstanding balances will remain forever unless they are manually "cleaned up". The Payments Due tab report can be used for finding unbalanced reservations and customers.

You can choose which transactions are purged -- unbound, customer, or reservation transactions. For instance, you may decide to only purge unbound transactions (generally counter sales) and leave any bound to customers and reservations for historical purposes. Or you can purge customer-only transactions (also usually counter sales), or all reservation transactions.

In addition to the transactions, you can purge the actual reservations that ended prior to the date. Again, this will only be done if the reservation "balances", unless the "Extreme" option is selected. Any transactions for the reservation will be purge automatically, whether you selected the option to purge reservation transactions separately or not.

Finally, customers who don't have any reservations or transactions can also be purged if desired, to help clean out old customers who don't return often. This is done **after** any other selected purgings above, so if all of its transactions and reservations are purged now, then it will also be purged now. There is also an option to only purge customers that have "never" had any transactions or reservations. If this is selected, it will check the "prior" transaction and reservation figures (explained below), and keep the customer if it has any history -- therefore, even if the customer's transactions and reservations are purged, it will be kept because it had history prior to the purge. This can be useful for cleaning out customers who were entered or imported from an old database but never returned since the software has been in use.

When all of the options are set the way you want, and you're sure you have a backup, you can click the "Purge!" button. The purge should only take a few seconds, and a dialog will show how many records of each type were purged.

"Extreme" purging options

There are options for "Extreme" Transaction or Reservation purging, but these should only be used if you're not concerned with keeping reporting consistent. Typically this would only be the case if you're taking over the park and wanting to start all over with a "clean slate". You can use these to clear all old transactions, reservations and even customers. Note that the normal A/R and Deposit balance adjustments added after purging may not be relevant when using these options, so it will be up to you to look for those and manually remove them or adjust them (perhaps through Raw Data Tables / Transactions).

Extreme Transaction Clean-Up -- With this option selected all transactions prior to the given date will be deleted. This is regardless of any balance, or even if those transactions are part of a current (or past) reservation that also has newer transactions not deleted. Therefore if it's used improperly, it can not only affect past reporting but also current reporting (especially Receipts by Category) and reservation balances. We recommend only using this if you're wanting to wipe out all transactions in the entire system (using a Prior-To date of today's date, for instance).

Extreme Reservation Clean-Up -- With this option selected, all reservations prior to the given date will be deleted. This is regardless of any balance, or even if those reservations are linked to more recent reservations. Therefore if it's used improperly, it can not only affect past reporting but also current reporting (especially Receipts by Category) and customer balances.

Customer Clean-up -- If you're wanting to also clear out old customers for the reservations (or transactions) cleaned up with the Extreme options above, select the "Purge old customers" option as usual. Be sure to not select "Purge old customers only if they have never..." option.

Keeping prior totals

Although the records are purged, a few "prior" balances are maintained for historical purposes (if the Customer fields are enabled -- see above).

When transactions are purged for reservations or customers, the total amount of payments made in those transactions will be saved (as a single value) and will show up on the Transactions History (done from Customer Details) . This is also added to any total from prior purges. Thus you can still get an idea of how much revenue each customer/reservation has been responsible for.

When reservations are purged, their customers will retain a running total of the number of days-stayed and number of reservations purged. This will show on the Reservation History dialog as a quick reference to show how much business they did in the past that's not still "live".

Keeping balances

Deposit and Accounts Receivable balances (if you use them) are maintained by making "Adjustment" transaction entries automatically. Generally this is only necessary when purging Unbound transactions, which don't have to balance to be purged, since the net balance for purged reservation and customer transactions should be zero. The "Operator" name for these adjustments will indicate that it's an automatic adjustment due to a purge.

Raw Data Tables

Each of the Raw Data Tables selections of the Maintenance menu will open a dialog with a grid showing one of the complete data tables. If you've been using the system for awhile, be sure you have some time to wait if you open the Reservation or Transactions tables, as these can be large and slow to open. These dialogs can only be accessed by an operator with Administrator access.

In general, these data table functions should be used only by someone who is very familiar with the database, because they contain some internal fields that aren't normally seen and major damage can be done if things are changed or records deleted. On the other hand, this is the only place that some database "corrections" can be done. This manual won't cover any specifics about this, but access to these tables may be required when calling for support. Each table has an Allow Editing of Fields check box, which is disabled by default, so that the tables can be browsed without worry.

That said, there are some good uses for the data tables for certain tasks.

Uses for the Data Tables

One potential use for the data tables is to print a list of customers, for instance. You need to use caution because the grid printout can be very large and will result in a report several pages "wide" as well as "tall". You can minimize the printing by using the Print Preview to figure out which pages are of interest. Then when you Print you can enter the start and end pages. If you need pages that are not in continuous range, like 1, 5, and 9, then you need to do three separate Print operations with the start and end pages both set to 1, then both set to 5, then both set to 9.

The grid on data table dialogs can be sorted by any column by clicking on the column header. This can make them potentially useful for finding a particular record, since all fields are available to sort by. You can also Export any table as a CSV file and open it in another program like Excel for manipulation.

The Sites data table can be very useful if you are setting up your sites and have a lot of site information to enter. Because the grids used here allow you to copy many fields at a time, and make many copies of a field, it can dramatically speed up the process. For instance, it can take only a few seconds to set hundreds of Site Type fields to the same value.

You may have noticed that the Parks table is not represented in the Raw Data Tables menu. This is because the Parks setup requires special handling due to the authorization codes, and cannot be manually edited.

Aside from the uses mentioned above, no changes to data tables should be attempted without consulting with the Cottonwood Software support staff first.

Working with Data Tables

The Data Tables dialogs themselves are very similar to the Pick List dialogs. There is a grid for the table with one record in each row. The controls are the same as well, except that only the Sites table has the Move Up and Move Down buttons (records in the other tables have no reason to be moved).

On the right side is a View Fields button -- this can be used to show all fields of a single record in a list, along with the internal time-last-changed information (for diagnostic purposes). This function can be also handy if the record has many fields and you want a snapshot of it, e.g. for printing or exporting. No changes can be made in this view. Note that the time-last-changed is new as of version 10, and also is not set the first time a non-blank value is set (it's only used to synchronize subsequent value changes) -- so don't be surprised to see this empty for most fields.

You will also see a check box on some of them: Show Links as Index values. When this is selected, any fields that use relation links to other tables (for instance the Site field in Reservations) will show the numeric index value instead of the human-readable form (e.g. the site name). This is for troubleshooting purposes only.

Warning -- Remember that the Sites table and the Operators table are the only ones that are reasonably safe to edit here. The other tables are generated by the software and should only be edited by an expert.

Warning -- There is no Cancel button -- any change you make to the tables is instant and permanent. This also applies to Deleting records.

Editing data tables is basically the same as for pick lists. One thing that can be useful, particularly on the Sites table, is the multi-copy operations. You can do two different kinds of multi-cell copying that can be useful.

Copying one value to multiple cells

This can be used to copy a cell to multiple cells in a column, multiple cells in a row, or a combination (multiple rows and columns in a rectangle).

1. Highlight one cell to copy (click on it once, it should change to a dark blue background).
2. Press **Ctrl-C** (or **Ctrl-Insert**) to copy that cell to the Windows clipboard.
3. Move the cursor to (or click on) the upper left cell you want to paste to so all are highlighted.
4. Use **Shift-arrows** to move to (or **Shift-click** on) the lower right cell you want to paste into.
5. Press **Ctrl-V** (or **Shift-Insert**) to paste the value into all highlighted cells.

Note that if it doesn't work, it may be that one or more cells in the range does not accept the copied text as a valid value. (Cell validation is done each time you change a cell, which could abort the entire paste operation.) Also make sure you have the Allow Editing of Fields box checked.

Copying multiple cells at once

This allows you to highlight a range of cells in a row or column or rectangle and copy them all to another location as a group. It can only make one copy of the cells at a time, however (e.g. you can't highlight one column and copy it to multiple columns at once).

1. Highlight the upper left cell to copy (click on it once).
2. Move the cursor to (or click on) the lower right cell to copy, so cells all are highlighted.
3. Press **Ctrl-C** (or **Ctrl-Insert**) to copy that cell to the Windows clipboard.
4. Click on the destination cell for the upper left cell copied.
5. Press **Ctrl-V** (or **Shift-Insert**) to paste all of the copied cells as a group.

Note that the copied cells are still on the clipboard after the paste, so if you need to paste multiple groups then you can repeat steps 4 and 5 over and over as needed. This is useful for copying many fields in one record to multiple other records.

Database Maintenance

Overview

The database maintenance functions are miscellaneous functions you can use occasionally to check the database for anomalies or make manual corrections. Database anomalies like bad links, orphaned transactions, etc. could occur as a result of internal program errors, accidental deletion of records through Raw Data Tables or Pick lists, database corruption due to a computer crash, or improperly restoring from a backup database.

Except for the balance adjustment functions, it's a good idea to run through these every few weeks just to make sure no problems are occurring that need to be corrected. The "orphan" functions and the bad-links function can correct the database automatically. Unmatched transfers need to be manually corrected.

Most of these functions require administrator access (at least to make any changes), but the Orphan and Unmatched Transfer reports can be viewed with Manager access so they can at least be monitored more readily.

Networking note: Since some of these functions require a large number of records to be locked and modified, it's recommended that you perform these only on the Master workstation.

Deposit Balance Adjustment

This Administrator-only function, accessed through *Maintenance / Database Maintenance*, is used to enter a manual adjustment to the overall Deposits balance. This balance is a running total of the amount of advance deposits received from customers than have not yet been "used", or applied toward reservation charges.

The dialog will show the current all-time totals for deposits received, deposits applied, any previous adjustments, and the current balance. When making an adjustment, you can either enter the adjustment amount (the new balance will change accordingly), or you can enter the new balance if you know it (the adjustment required will be calculated accordingly).

Either way, just click Save when finished, and the adjustment will be added as a new unbound transaction. As with other transactions, this adjustment will be tagged with the time, date, and operator. You can see the adjustment on the Transactions reports (tab view).

If you make a mistake you can either enter a new adjustment, or you can edit the transaction through the Transaction tab view (right-click on it, select Transactions).

A/R Balance Adjustment

This Administrator-only function, accessed through *Maintenance / Database Maintenance*, is used to enter a manual adjustment to the overall Accounts Receivable balance. This balance is a running total of the amount of charges to customers than have not yet been paid.

The dialog will show the current all-time totals for charges (including taxes & discounts), payments received (reduced by refunds/credits), deposits applied, any previous A/R adjustments, and the current balance. When making an adjustment, you can either enter the adjustment amount (the new balance will change accordingly), or you can enter the new balance if you know it (the adjustment required will be calculated accordingly).

Either way, just click Save when finished, and the adjustment will be added as a new unbound transaction. As with other transactions, this adjustment will be tagged with the time, date, and operator. You can see the adjustment on the Transactions reports (tab view).

If you make a mistake you can either enter a new adjustment, or you can edit the transaction through the Transaction tab view (right-click on it, select Transactions).

Report and repair Orphaned Transactions

This pair of functions (one for Reservations and one for Customers), accessed through *Maintenance / Database Maintenance*, will report and repair situations where a transaction is in the system and linked to a reservation, but the reservation's link to the transaction has been broken (or likewise for customers). In this case, it looks like everything is fine from the point of view of the Transactions tab view, reports, etc., but if you look at the Transactions for the reservation (e.g. through Reservation Details), the transaction does not show up and is not added to the balance. This is most likely due a program crash and/or incomplete database recovery.

If there are no orphans found, a simple message will appear saying there are no problems.

If any orphans do exist, each orphaned transaction will be shown in a list with the most relevant details. You should print this list before making any changes, just in case you find out later that fixing the problem causes balances to be incorrect. (This can result if the operator added the transaction again, after seeing it missing from the reservation.)

First you should check each transaction determine if it should be fixed or deleted. Double-clicking on the transaction will open the Transactions dialog for the given reservation or customer. Naturally, since it's orphaned, the transaction won't show up there. What you need to determine is whether the transaction should be there, or whether another transaction has already been added to replace it. Generally this can be determined by the balance due, but checking more details may be necessary.

If the transaction should be deleted (i.e. it would be a duplicate if it was fixed to show up on the reservation), then click the transaction in the list to highlight it, and click Delete Selected Transactions. If it should be fixed (i.e. you want it to show up on the reservation), then leave it in the list.

Once all transactions have been checked, then click the Fix... button at the bottom to fix any that are in the list. The links will be repaired automatically so the transactions will appear on their respective reservation or customer transaction lists.

Report and repair Orphaned Reservations

This function, accessed through *Maintenance / Database Maintenance*, is very similar to the Orphaned Transactions function. It repairs internal database links where the reservation knows what customer it belongs to, but the customer does not show the reservation in its Reservation History. While this is only a minor problem since it won't affect any reports and will rarely be noticed, it should be corrected.

If there are no orphans found, a simple message will appear saying there are no problems.

If any orphans do exist, each orphaned reservation will be shown in a list with the most relevant details. Since it's most likely that an reservation orphans should be corrected (even if they were subsequently canceled or checked out), it's recommended to simply click the Fix... button to correct all of the links. If you do want to make adjustments to the reservation first, you can double-click on it to go to Reservation Details.

Report Conflicting Reservations

While the program has many safeguards against double-bookings (reservation conflicts), they can happen if changes are made to raw data tables or when importing data from another system. This function, available through *Maintenance / Database Maintenance*, will check the entire database for any reservation conflicts and show them in a list that can be printed out. You can also view the reservation details and make corrections directly from the list.

There is also an option to include waiting-list reservations. While waiting-list reservations would usually not have a site assigned and thus could not conflict, there may be cases where a specific site was requested for the waiting list. Enabling this option will show any "conflicts", which in this context would mean that the requested site is still not available for the wait-listed reservation.

Reservations that are Canceled will not be shown, nor will Inquiry, Can't Book, or Day Pass reservations. Guest and Owner reservations will not be shown because they are never considered "conflicts" (they can appear on the site at the same time as a normal reservation).

Report Unmatched Transfers

This function, accessed through *Maintenance / Database Maintenance*, will list any Payment or Deposit Transfer transactions that appear to not have a "matching" transaction for the other side of the transfer. (Transfers always consist of two transactions -- a positive transfer in to a reservation or customer, and a negative transfer out of another reservation or customer.) Unmatched transfers can occur if a transfer is deleted and the operator does not answer "Yes" to the prompt to delete the other side (or in older software versions where this wasn't automatic), or due to program crashes with incomplete database recovery.

You should always Print the list before making corrections just in case you make a mistake and need to see what was there before.

There is no function to automatically correct unmatched transfers, so you will need to manually correct each one. This most likely means deleting it, and adding a new transfer if necessary. To make corrections, double-click on one of the transactions in the list to get to the reservation or customer Transactions dialog. From there you can investigate and correct the problem.

Repair <bad links>

This function, accessed through *Maintenance / Database Maintenance*, will check all of the records for having "bad links", which are essentially links to records or pick-list values that no longer exist. Bad links can be a result of deleting pick-list items already in use, improper editing of raw data tables, program errors, and computer crashes/lockups. While bad links normally cause no problems, it's a good idea to clean them up once in awhile just in case they affect some function in the future.

Note that when you use this function there will be one prompt asking you if you're sure you want to do it, and then it will be an instantaneous action (more or less). There is no way to cancel it once it starts, so it would be a good idea to do a backup beforehand just in case.

Show the current database location

This function, available through *Maintenance / Database Maintenance*, can be used by any level of operator by default (but this can be changed through the Access Levels). It simply shows the path to the current database on the disk, as well as the path to the auto-open database. These two locations are often the same, unless you've opened a different database manually or you're using the "demo" database.

Move the database to Shared or Public Documents

This function is only available if you're running under Windows XP or Windows Vista, and is accessed through *Maintenance / Database Maintenance*.

Due to file access restrictions for some users in Windows XP, and due to general access restrictions under Windows Vista and later, the practice of putting data files under the Program Files folder (with the application itself) no longer works properly. If you still have the database in the old location, or if it has somehow been located in somewhere other than a "safe" location where all users have access to it, then you can use this function to easily move the database file and all associated files (maps, logs, auto-backups, etc.) to the proper "default" location.

Note that it still leaves a copy in the old location, for safety (an extra backup in case the new location doesn't work or the copy fails). Once you move the database, it is safe to delete the database file (.prk), log files (*.prklog), backup files (*.zip) and bitmap field (*.bmp). Be careful not to delete all files though, since this may delete the program itself.

Default database location

The default location of the database, e.g. where it's saved if you use "New Database", and what's considered a "safe" location, depends on the version of Windows you're using.

Note that for Campground Master versions prior to 4.2, the default location is always C:\Program Files\Campground Master\ -- and this option to move it is not available. You would need to manually move the files if necessary.

For Windows 95, 98, ME, NT 4.0 and 2000, the default is C:\Program Files\Campground Master\. The function to move the database will not be present since there's no need to move it.

In Windows XP, the proper location is in a "Campground Master" folder under "Shared Documents" (which is usually equivalent to C:\Documents and Settings\All Users\Documents\).

In Windows Vista or later it's in a "Campground Master" folder under "Public Documents" (which is usually equivalent to C:\Users\Public\Documents\).

Copying To a New Computer

There are a few reasons you may need to copy your entire Campground Master software and data to another computer. Perhaps you bought a new computer, or want a backup on a home computer, or you're adding another computer to the network. In any of these cases, just follow the steps below.

Copying the software usually just involves a few simple steps, assuming you still have access to the old computer or another computer (e.g. networked) with a current copy of your database:

Quick overview: (see the detailed instructions below if you don't know how to do all of these)

1. Download & install Campground Master from our web site. (<https://campgroundmaster.com/downloads.html>)
2. Make a Backup of the database from the old/existing computer.
3. Use New database to create a database on the new computer, and Restore the data from your backup.
4. If networking to other computers, do the Network setup to get it connected.
5. If it's a new networked computer, see if any workstation-specific settings need to be configured.

That's all there is to it. No authorization code is needed for installation, since that's in your backup.

If you no longer have a working computer with Campground Master running on it with your database, and have no recent backup file to restore from, then you may still recover the database from the old hard drive if you can access it. See the next topic, "Recovering a database from an alternate hard drive".

Detailed step-by-step instructions:

These are given in general terms because specifics may vary, but only basic computer knowledge is required. If you're still not sure how to do a particular step, consult your computer support person.

If restoring an existing backup to a new computer: If you already have a backup and just need to install it to a new computer, start at step 6.

Windows upgrade note: If you're upgrading to a new version of Windows, you should do steps 1 through 5 below **before** upgrading Windows so it's easier to restore your database after upgrading. Otherwise you may need to use the procedure "Recovering a database from an alternate hard drive" to locate the database file.

1. Make a backup of the current database (assuming you still have it on a working computer) using the Maintenance / Back Up Database function. If you're running Campground Master on multiple computers (e.g. a networked system or as a backup), you can do this from any computer with current data on it -- it doesn't have to be done from the exact computer you're replacing. If you're adding a computer to the network rather than replacing one, just make the backup from the Master computer.

You'll need to save or copy the backup to a USB memory stick or other location where you can get to it from the new computer. **Be sure to correctly select the "Save in" at the top to specify where it's saving it when you do the backup.**

Tip: We suggest using some unique filename you'll recognize when restoring. It's easy to forget where it was saved and accidentally try to restore the wrong file later, so using some unusual name like "John's Friday the 10th backup" will ensure that you are selecting the correct file later.

2. Use Maintenance / Restore from Backup on that same computer to verify that the backup copy is readable. (Don't worry, if it's not readable then your current data won't be altered.)

3. If you're using a version prior to 4.0: Also copy any map image files (.bmp files that are located in the same folder as your database) onto your backup disk. If you're not sure what folder that is, go to Maintenance / Program Options / Database, and look at the current database path. The map images are not part of the normal backup in older software versions, so these need to be copied separately, using normal file copy functions in Windows Explorer or My Computer. If you're not sure which .bmp files are being used, go to Maintenance / Park Setup / Maps and check the File names (not the map Names). Also if you use any "bitmaps" on custom Forms, for instance a company logo for your receipts, those BMP files need to be copied separately.

4. If you're using the Export to Web function: Copy any template files (.htt files) that you're using. These might be in a different location -- see File / Export / Export to web vacancy grid(s) to check the template file location.

5. You'll need to know what version you've been running so that you can install the same version on the other computer. Check Help / About Campground Master to see what version you're running.

6. Locate an installation disk or download file for the same version you're currently running. All major versions can be downloaded from our web site if necessary. (See <http://CampgroundMaster.com/downloads.html>) If you're not authorized for the latest version, use the "Previous Versions" button at the top of that page to find your version. If you can't locate the exact version then use the next higher version, assuming you're authorized to upgrade to it -- but be sure to also update any other computers that will still be using Campground Master.

NOTE: Do not use your original installation disk unless you're sure it's the same version you've been running. There is no need to install from an older version disk if you're going to be installing an updated version from the web site anyway.

7. Install the appropriate version of Campground Master (from the disk/download in step 6) onto the new computer.

8. Run Campground Master. It doesn't matter whether you load the sample (demo) database or not. However if it loads some old database and you don't know the login password, then you may need to get around that -- see the note in step 9 below. It may also show errors about not being authorized for this version -- ignore those and continue to the next step.

9. Go to Maintenance / New Database (create a new database file). It will ask you for a database name, so enter the same name as your database used before. **IMPORTANT:** If this will be networked with other computers using Campground Master, then the database name must be exactly the same as it is on the master (server) computer (or if you're replacing the master, it must be the same as before, which is also the same as used on the other computers). You can find the database name in the caption bar at the top of Campground Master (after "Database:"). Spacing and any punctuation is important.

Note: If you're doing this on a computer that had a previous database on it (from a prior installation of Campground Master) and it's opening that database automatically, and you don't know the Administrator login for that database, then you won't be able to get to the [New Database](#) function. If you're running version 10.0 or later, then close Campground Master and hold the **Shift** and **Ctrl** keys down while launching it again to skip any auto-open or command-line-specified database loading. Then you can get to the [New Database](#) function. If you're running a version prior to 10.0, then you will need to contact support to get a temporary login so you can access the [New Database](#) function.

10. If you copied any extra files from step 3 or 4 above, go to [Maintenance / Program Options / Database](#) to determine the current database location, and copy those files from your backup disk to that folder (using Windows Explorer or My Computer to copy the files).

11. Go to [Maintenance / Restore from Backup](#) to restore from the backup -- you'll probably get a couple warning messages, and then be sure to select the correct backup file in the Open dialog (**select the location in the "Look in" drop-down list**). (Using a unique name as suggested in step 1 helps to know you got the right file.)

Note: If you don't see the file you backed up in step 1, then it's most likely that you didn't restore from the correct file. This is most often due to not selecting the correct "Save In" in step 1, or not selecting the correct "Look In" in step 11. Likewise, if you don't see your data after restoring, and/or your login doesn't work, then you are not restoring from the correct file. Review steps 1 and 11.

12. If all looks OK, go to [File / Save](#) to make sure it's saved to the hard disk.

Note: If you're getting errors about not being **authorized** for this version and it won't save the database, then either you have not purchased the upgrade to this version, or else you just haven't entered your current authorization code. Contact support for assistance.

13. **Important:** If this is part of a multiple-computer (networked) setup, see additional notes below for required [networking configuration](#).

At this point you should have Campground Master running and showing your data on this computer. If it's not showing your data, start again with step 1, making sure the backup is done with a unique name so you are restoring from the correct file.

Any supporting software, such as X-Charge, printer drivers, etc. may also need to be re-installed on the new computer.

Also keep in mind that the printer selection and options in [File / Printer Setup](#) are computer-specific, so you may need to do review those for having the correct printer selected if you don't use the default printer settings for everything.

Networking configuration:

For a networking setup, whether this will be a replacement master/server or a new client linked to an existing master, you'll also need to set the appropriate network settings so it can connect to the master (or become the master, as the case may be). For instance if this is a replacement for a network workstation, be sure to assign it the same workstation ID as the one it's replacing.

For example:

- If it's going to be a **Client**, you need to go to [Maintenance / Network Setup / Network Settings](#) to set the appropriate "This workstation ID", "Master's ID", and "Master's IP address". (It will appear to be another master, not linked to the other computers, until you do this!)

- If it's a **Master/Server**, you need to find its IP address (and preferably set it as "static" in Windows), and configure all other clients to point to this new master. This could also involve changes to your router's Port Forwarding if you're connecting from a remote client.

See the Networking documentation for details, and also review the notes below.

Important networking note: If you're changing which computer is going to be the Master, be sure to refer to "Changing the Master Computer" for details.

Workstation-specific settings for new computers

If you're setting up a new networked workstation (e.g. adding a workstation ID 2 for the first time), then be aware that there are a lot of workstation-specific settings you may need to configure for the new workstation. Note that this doesn't apply if you're just moving or re-installing with a workstation ID number that was used before.

Note: You can take a shortcut and synchronize most workstation-specific settings to be the same as the Master in one step -- however this will affect all workstations, not just the new one, so make sure you don't have some settings different on purpose. See "Synchronize local options to all workstations" under Maintenance / Network Setup.

1. Most important would be the Credit Card Processing Setup, if you're processing cards through Campground Master. You'll need to configure the new workstation to have the same settings as the other workstations. Note that the "Synchronize local options to all workstations" function mentioned above does **not** synchronize these because this could cause problems in some cases.
2. Any Tab View Options and default site filters, etc. are workstation-specific. While it's not critical that these be the same (they may be different on purpose), be aware that things may look different if the options are not the same.
3. Printing Options are workstation-specific. See Maintenance / Printing Options.
4. SMTP setup may be workstation-specific, unless you're using the "Global" option.
5. The default settings for most Reports (meter lists, occupancy report, etc), like filtering, grouping options, etc., are workstation-specific. While these are often changed each time you use them anyway, there may be common settings you are used to having set up already.

Recovering a Database from an Alternate Hard Drive

This should be a last resort recovery effort, only used if you have no current database on a computer with Campground Master, and no alternate backup file. If you have a recent backup or you have any computer that can run Campground Master and has current data, use the procedure "Copying to a New Computer" in the previous section.

This assumes you have access to the hard drive from a computer that was running Campground Master, or otherwise have copy of the hard drive or data folder that you can directly access from the new (or recovered) computer that will be running Campground Master.

Here are the basic steps:

1. Download & install Campground Master from our web site.
2. Use New database to create a database on the new computer, mainly to set up its location.
3. Copy the data files from the old hard drive / data location to the new database location.

4. Make sure the correct database file is set as a default.

No authorization code is needed for installation, since that's in your old database.

Here are more detailed steps:

These are given in general terms because specifics may vary. Only basic computer knowledge is required for most steps. If you're not sure how to do a particular step, consult your computer support person.

1. If you haven't been keeping current with updates renewals and thus can't use the latest version of Campground Master, you'll need to know what version you've been running so that you can install the same version on the other computer. If you don't know this, contact support and we can tell you the latest you're allowed to use.

2. Locate an installation disk or download file for the same version you've been running. All major versions can be downloaded from our web site if necessary. (See <http://CampgroundMaster.com/downloads.html>) If you're not authorized for the latest version, use the "Previous Versions" button at the top of that page to find your version. If you can't locate the exact version then use the next higher version, assuming you're authorized to upgrade to it -- but be sure to also update any other computers that will still be using Campground Master.

NOTE: Do not use your original installation disk unless you're sure it's the same version you've been running. There is no need to install from an older version disk if you're going to be installing an updated version from the web site anyway.

3. Install the appropriate version of Campground Master (from the disk/download in step 2) onto the new computer.

4. Run Campground Master. It doesn't matter whether you load the sample (demo) database or not. However if it loads some old database and you don't know the login password, then you may need to load the sample database so that you can get logged in (automatically). This might require downloading the "Free demo" from the web site, if you no longer have a Demo icon to start it from.

5. Go to Maintenance / New Database (create a new database file). It will ask you for a database name, so enter the same name as your database used before if you remember it. However it's not essential that it be the same, we'll handle that later. This is mostly just to initialize the proper data folder.

6. This is the most complicated part if you're not a seasoned computer user. You need to locate the old database. The easiest way to do this is to use the "Search" function in Windows (also called "Find Files and Folders" in some versions), which you can access through the Start button in Windows, for instance.

Search for files named "*.prk" on the drive with your old data (the asterisk is a wildcard that matches anything, so that means find any file with .park as the extension). That should show you a list of files, and now you need to decide which one is correct. Make sure you can see the "Date modified" for the files. For the most part you will want to find the one most recently modified, excluding the one that you just created in step 5 above. You probably won't want "demo", and also ignore any with "pre-restore" in the name.

Once you've located a likely candidate, make a note of its location (folder or path).

7. Back in Campground Master, use File / Open to open the file found in step 6. Be sure you're looking in the right folder in the Open dialog (**select the folder location in the "Look in" drop-down list**). Once you've located it, click Open. You'll probably get some warnings about it not becoming the default database, etc. You might also get a prompt saying that "Changes are present that are not in the database...", in which case you should answer Yes.

8. You will be prompted to log in. The login should be the same as you've been using, since operator logins are stored in the database. If you're sure that you're using the correct login but it does not accept it, then it's probably not the correct database file -- try another one from step 6. Also, be sure to use an Administrator level login. If you can't remember an administrator login that works, contact support.

8. Verify that the data looks correct. If not, go back to step 6 and try to find another candidate file to open.

9. If it looks like the correct data and you can log in, then you need to move the database to the correct location and make it the default. Go to [Maintenance / Database Maintenance / Move the database to shared or public documents](#). It should show you a confirmation, answer Yes. It may also say that there is already a database there by the same name (e.g. if you used the same name in step 5), which is fine -- go ahead and move it.

10. It may have told you in step 9 that the database is now the new default. If not, then you need to make it the default. Go to [Maintenance / Program Options](#), and click on the Database tab. Verify that the Current database path begins with "C:". If it starts with any other letter, then step 8 was not completed correctly, try that again. If it does start with "C:", click the long button that says "Change the Auto-open database to the Current database" and confirm the prompts.

That should be it, your old data has been successfully moved to the correct location on the hard drive.

Notes:

If you're networking multiple computers (and presumably they are not set up yet since you're using this procedure, otherwise you could have used the simpler one to copy to a new computer from a networked computer's backup), then you need to go through the Networking Setup process, including copying this database to the other computers.

Any supporting software, such as X-Charge, PC Charge, printer drivers, etc. may also need to be re-installed on the new computer.

Also keep in mind that the printer selection and options in [File / Printer Setup](#) are computer-specific, so you may need to do some tweaking there also if you don't use the default printer settings for everything.

Multiple Databases on One Computer

This explains how you can handle separate databases in order to keep reporting separate for different business entities, or for instance you get multiple databases from different parks that you need to open for accounting purposes.

IMPORTANT -- If you are also **networking** one or more of the databases, e.g. it will have a live connection to another computer, then **do not use** this example. Refer to [Setting Up Multiple Connections](#) in the Networking chapter instead.

To open multiple databases from one computer, you will first need to have a copy of each park's database, e.g. a backup copy. You will use the same procedure as [Copying Campground Master to a New Computer](#) to make a backup, create a New Database, and Restore the database from the backup. Refer to that section for details.

Setting up multiple shortcuts

Once you have the separate databases created, you can make it easy to open each one by creating separate shortcuts on your desktop.

Lets say you need to open 3 different databases. Start by copying the normal Campground Master shortcut on your desktop (and give each one a different name). Then set up each shortcut to load a different database by changing the Target in the shortcut's Properties. For instance if the databases are named "Park One", "Park Two" and "Park Three", set up the shortcut targets like this:

```
"C:\Program Files (x86)\Campground Master\CampgroundMaster.exe" Park One
```

```
"C:\Program Files (x86)\Campground Master\CampgroundMaster.exe" Park Two
```

```
"C:\Program Files (x86)\Campground Master\CampgroundMaster.exe" Park Three
```

(Note that quotes are not needed around the database names.)

Enabling multiple program instances

Normally it will only allow one copy of Campground Master to run at a time, so you could only open one database at a time. However if it's important for you to open more than one at a time, then you need to enable multiple instances of Campground Master.

In the file "Campground Master.ini", put the following setting in the **[Main]** section:

```
AllowMultipleInstances=1
```

The Campground Master.ini file will be found either in "Public Documents\Campground Master" (in Windows Vista and later), or "Shared Documents\Campground Master" (in Windows XP), or in the C:\Windows\ folder (in older versions of Windows or in Campground Master versions prior to v4.2). This is a simple text file so you should edit it with Notepad to insert the line above. It can be added anywhere after the line containing [Main], so putting it right after [Main] is simplest.

Advanced Customizations

Overview

The functions in this section can be used for many things, from making minor changes to a receipt format to making extensive changes to the system's functionality.

NOTICE:

These features are considered to be advanced development tools built in the program and are documented sufficiently for an experienced programmer or someone proficient with database design. Some sample forms and reports are provided which can be used as-is, modified for your needs, or studied as examples.

Our normal technical support will answer basic questions about the capabilities of these functions, but we cannot explain detailed examples or provide training for expressions programming, or debug changes that you've made. It can take some time to learn the details of these functions, even for experienced programmers, since they use a unique "language". If you don't have someone available with the time to experiment and learn these functions sufficiently to create the forms or reports you need, we can create forms or reports for an additional charge.

The "Advanced Customizations" functionality is considered an advanced customization system for Campground Master. Most users will be able to accomplish everything they need to without creating their own reports and forms. Before delving into these functions, we suggest that you thoroughly learn the rest of the system setup and investigate the other options -- there's a lot of flexibility already present in the various Tab View Options, Printing Options, Program Options, Data Field Definitions, Pick Lists, and Park Setup functions. If none of the normal options accomplish exactly what you want and you need to make a specific change to a tab view, receipt form, color coding or other functionality, then you can probably accomplish it through this section. However, we recommend that you do check the other options and/or contact us first to see if it can be done with normal options changes instead.

Samples

There are a number of sample Forms, Queries, and Color Schemes installed with Campground Master (in the Samples folder). These can be imported and used as-is, or you can make adjustments for your needs, or just look at them as examples. For details on importing the samples, refer to each of the following "Setup" sections according to what you want to import.

Tab Views Setup

The Tab Views in Campground Master are initially configured with all of the normal content views -- Rack, Arrivals, Departures, etc., and will include a Map and/or Query view if any maps or queries are set up. You can change the configuration of these views through Maintenance / Advanced Customizations / Tab Views. There are several reasons you might want to do this:

- To change the operator access levels for viewing or printing each view.
- To change the order, e.g. to make Map the first view so it's shown by default.
- To rename them to something more to your liking
- To make the names shorter to fit on a low-resolution screen
- To remove views that you never use
- To add multiple Query views showing specific queries by default
- To customize what happens when double-clicking in the view

Note that changes to the tab view setup apply to all workstations.

Tab View Setup

The Tab View Setup dialog lists all of the tab views with their general information. Tabs are shown here whether they're enabled or not. If there's one that you don't plan to use, we recommend that you Edit it and uncheck "Enabled", rather than deleting it from the list. This way it's easy to re-enable later.

The order of views in the list will be the order they're displayed in Campground Master (skipping disabled ones of course). Note that any Map or Query views will only appear if one or more maps or queries are set up.

You can use the typical functions to add, edit, copy, move or delete tab views in the list.

Add the default tab views

This special function will add all of the default views to the list (which may result in duplicates). The main purpose of this is if you make some changes and then want to get back the original settings.

Note that if you delete or disable all tab views, the Rack view will still be shown by default (the program can't function without any tab views). If you re-enter Setup, it will prompt you to add all default views back in. It will also add all views back in automatically when you re-start the program.

Adding or Editing Tab Views

When you Add or Edit a view (or double-click on it in the Tab View Setup list), a simple dialog will allow you to enter the name, type, access levels and notes. You can also disable or re-enable it.

Tab Name

The name you enter here will be used as the header (name) of the tab, and also for the heading if you print the view.

Note that if you add tabs or change the names, you may not be able to see all of the tabs on the screen at once. If this happens, a pair of right/left arrows will be shown on the right side, which you can use to scroll the tabs back and forth. However it's usually better to get all of the tabs to fit on the screen. You can do this by shortening the Names of the tabs -- you'll notice that the tabs must all be the same size, so it uses the largest of the tab names to determine the size of all tabs.

Likewise, if you have extra space and prefer to widen the tabs, you can use longer names or even put spaces on each side of the longest name to force the tabs wider. You may already see this in the default "Payments Due" tab, if your screen is wide enough. Remember that these settings are used on all computers, so you'll have to keep the lowest-resolution screen in mind.

Content Type

The Content type is a selection list of the standard tab view types. The only special one is Query. In this view, you have the option to select a specific query to show. This essentially allows you to create a custom tab view using a query you've defined. If you select a query here, then only that query will be shown with no option to change it on the tab view. If you don't select a query, then the tab view will have a drop-down list where you can select a query. Thus you can have some "fixed" query tab views that show reports you need most, and also have a standard "Query" tab that allows you to dynamically select any query you've created.

Note that only one enabled entry is allowed for each of the types, except Query. There's no reason to add multiple Arrivals views, for instance, because they would be the same (they can't be set up with different options just because they're on different tabs).

Access Levels

You can select the operator access level required to view and print each tab view.

Double-click actions

These settings allow changing what happens when you double-click on a Reservation or a Site, specific to this Tab View. This will override the default action specified in Program Options / Functions, This allows you to specify a different double-click action for each of the Tab Views, so for instance you can have it do Check In on the **Arrivals** tab, Check Out on the **Departures** tab, Assign Site on the **Unassigned** tab, and open Transactions on the **Transactions** tab.. You can select one of the common functions listed, or you can enter a custom Expression (e.g. to run a custom script), allowing infinite flexibility. When "Execute Expression" is selected, click on the text box to the right of the drop-down list to edit the expression.

On a Reservation -- Select an action for double-clicking on Reservations, e.g. the customer's name/label on the Rack, an occupied site on the Map, or any cell related to a Reservation on other tab views (except the Site name or Type). For the Transactions tab view, this includes any transaction field that is linked to a Reservation.

On a Site -- Select an action for double-clicking on a Site, e.g. the Site's Abbreviation or Type on the Rack, or the site's Name or Type on one of the other list-type tab views. On the Rack and Map, double-clicking on an available site/date will always open "New Reservation", however the action selected here will be used if the site is Unavailable for the date. On the Transaction tab in detail view, this action will be used if the transaction does not belong to a Reservation (which of course means it has no Site either, so if showing Site quick-info that will be empty as well).

Override default Quick-Info window text

If you still want double-click to open a "Quick-Info" window, but want different or additional information to show in the window, you can use these settings to do that. This also applies to the right-click menu functions "Reservation Quick-Info" and "Site Quick-Info", regardless of the double-click action.

By default these expressions should be empty, which means it will use the normal Quick-Info window text. If you enter any expression, it will **replace** the normal text with the result of the expression (which of course must be a text result). There are expressions that will let you get the normal default text, making it easy to still show the normal information but add additional info to it. For example to add a custom field called

Resv_User_Gate_Code to the bottom of the reservation Quick-Info (after a blank line and label), you would enter the expression:

```
ResvQuickInfoText(Resv(), ThisDate()) + "\n\nGate Code: " + Resv:Resv_User_Gate_Code
```

Reservations -- This expression replaces the Quick-Info text for Reservations. Use the function ResvQuickInfoText(Resv(), ThisDate()) to get the default text for modification as shown above, on the given date (e.g the date selected on the Rack). Note that this will include any Conflicting reservation information for the date specified (or you can use 0 for the date to exclude it).

Sites -- This expression replaces the Quick-Info text for Sites. Use the function SiteQuickInfoText(Site(), ThisDate()) to get the default text for the site on the given date (e.g the date selected on the Rack). Note that this may include a note that the site is Unavailable for the date specified if applicable (or you can use 0 for the date to exclude it).

Note that the Quick-Info expressions are set separately for each tab, and there is no global setting as there is for the double-click actions. Therefore you would need to copy your expression to each Tab View definition to make it show the same on each Tab View.

Override default mouse-over tip text

You can specify special information to appear as the "Tip Text" when you hold the mouse over the reservation on the Rack and Map (or the customer's name on other tab views), and also for sites. By default these expressions should be empty, which means it will use the normal Tip Text. If you enter any expression, it will **replace** the normal text with the result of the expression (which of course must be a text result). There are expressions that will let you get the normal default text, making it easy to still show the normal information but add additional info to it. For example to add a customer's phone number to the reservation Tip Text in parenthesis, you would enter the expression:

```
ResvTipText(Resv()) + " (" + Cust:Cust_Phone_1
```

Reservations -- This expression replaces the Tip Text for Reservations. Use the function ResvTipText(Resv()) to get the default text for modification as shown above. This normally includes either the Label field for the reservation or the customer's Last name and First Name, possibly with additional information like "+ 1 Guest" or "[Group]".

Sites -- This expression replaces the Tip Text for Sites. Use the function SiteTipText(Site()) to get the default text for the site. This is normally the Description field of the site (or Name field if the description is empty).

Note that the Tip Text expressions are set separately for each tab, and there is no global setting. Therefore you would need to copy your expression to each Tab View definition to make it show the same on each Tab View.

Expressions

Overview

The "Expressions" functionality, or more specifically the expression processing engine, is the primary mechanism which allows extensive customization of forms, queries, reports, color schemes, and other elements of Campground Master. This is essentially a programming language with many built-in functions to access data, manipulate information, and generally get at any particular information you need. Since expressions are used in all of the advanced customization functions, you will need to get familiar with them in order to do your own customization.

In simple terms, an expression can be thought of as a calculation, or mathematical expression. If you're familiar with formulas in Microsoft Excel, or expressions used in Microsoft Access or dBase queries, then you'll have a big head start. For Scripting, familiarity with programming languages like Basic or C will help.

Expressions can be very simple or very long and complex, but every expression ultimately evaluates into a single value. This value can be a number, a string of text, a date, a boolean (true/false) value, or a data record pointer. The type of expression needed depends on the situation. For instance, boolean expressions are used in many places for filtering data or where conditional logic is needed like color schemes. Numeric expressions are used where calculated numbers are needed like transaction reports, and text expressions are used where text should be displayed such as receipt forms or query columns.

Macros are single expressions that can be called by name, with optional replacement parameters. They allow re-using common expressions, or simplifying things by calling a complex expression inside another expression. If you're familiar with Macros in the C programming language, they basically work the same way.

Scripts are a list of multiple expressions for performing more complex calculations, which can be called like a function from another expression. This is similar to defining a function in C or a procedure in Visual Basic or Pascal.

Expression Syntax

An **Expression** is simply a formula with values and functions, or at least one side of a formula, which evaluates down to a single value. The primary power of expressions comes from the built-in functions for extracting data values, converting and manipulating values, and making things happen.

An expression may contain the following elements:

Operators : +, -, >, etc.

Numeric values : 2, 5.3, .005, etc.

Text values : "Hi", 'a', etc.

Boolean values : .T. or .F.

Date values : {1/1/2005}

Function calls, often with parameters : Upper("hi")

Variables, user-defined : R, Total, etc.

The lowest-level format of an expression is a single value or function, or two expressions separated by an operator.

Here are some simple examples of expressions:

```
"Hello world"
2 + 2
Pi() * (R ^ 2)
Percent( 55/100 )
Resv:Resv_Adults > 2
iif( Resv:Resv_Adults > 2, "Extra adults present", "Two or less adults" )
FieldDate( ThisResv(), "Resv_First_Date" )
"Today is " + DateToText( Today() )
"Tomorrow is " + DateToText( Today() + 1 )
MessageBox( "Last name is " + FieldText( ThisCust(), "Cust_Last_Name" ) )
```

For a complete list of operators, functions, and other expression elements you can use, refer to the Expression Elements dialog. This is available anywhere expressions are entered so that you can build expressions by selecting from a list rather than memorizing functions or typing everything in.

Operators

For most programmers, especially C and C++ programmers, the operators will be familiar. Here's a list of possible operators in expressions:

Mathematical operators (used with numeric values, numeric results)

- + or - can be used as a unary operator. There must not be a space between this and the value following it. Examples: **+5, -10 -Len(cText)**
- + -- Add. Can also be used with dates to add a # of days, and with text to concatenate. Examples: **3 + 2, Today() + 3, "Name:" + Cust:Cust_LName**
- - -- Subtract. Can also be used with dates to subtract a # of days. Examples: **3 - 2, Today() - 30,**
- *, / -- Multiply and divide, respectively. Examples: **2 * 3, 2 / 3**
- ^ -- Raised to the power. Example: **2 ^ 3** (equals 2 times 2 times 2)
- % -- Modulo, or remainder. Gives the remainder after division. Example: **10 % 4** (the result is 2)

Conditional operators (Boolean results, used in condition expressions)

- > -- Greater than. Example: **3 > 2**
- < -- Less than
- >= -- Greater than or equal to
- <= -- Less than or equal to
- =, == -- Equal to (both work the same)
- !=, <> -- Not equal to (both work the same). Example: **Len(cText) != 3**
- AND, && -- Logical "And" (for boolean values, both must be true for the result to be true). Example: **Empty(cText) AND Empty(cName)**
- OR, || -- Logical "Or" (for boolean values, result is true if either values are true). Example: **Empty(cText) || Len(cText) = 4**
- NOT -- Logical negation, e.g. makes boolean True become False. A space should follow it. Example: **NOT Empty(cText)**
- ! -- unary version of NOT. There should not be a space following it. Example: **!Empty(cText)**

Operator Precedence

As with any programming language, some operators have higher precedence, or priority, than others. This is the order of precedence, with the highest priority on top:

1. + or - unary operator
2. NOT, !
3. ^
4. *, /, %
5. +, -
6. >=, <=
7. =, ==, !=, <>, >, <
8. AND, &&
9. OR, ||

Of course you can use parenthesis around expressions to force priority, like `((23 + 5) * (3-1)) % 3`.

Value Types

As hinted at above, there are several different types of values. Expressions are largely "type-safe", which means that in most cases you must use the expected type of value or else a parsing error will occur. For instance if a function requires a numeric value argument, then any other argument type will create an error. Also most operators must have matching types on each side (see the Syntax Rules).

Numeric values -- Integer or floating point numbers, using digits, a decimal and an optional minus sign in front. Do not include commas (e.g. 10,000 should be entered as 10000). Scientific notation (e.g 2.3E+9) is not allowed.

Character/Text values -- Anything enclosed in single or double quotes is considered text. There is no difference between single-character text and text strings. Quotes of the same type cannot be nested, but mixed single/double can be nested -- e.g. "He said "Hi!" is not correct, but 'He said "Hi!" is correct. If you must use the same kind of quote in the text, it can be "escaped" with a backslash: "He said \"Hi!\"" will work. Also, text should not contain any control characters, like the return or linefeed characters.

In some special places where long text is used such as in Forms definitions or MessageBox() messages, the escape sequence "\r" can be used for return, as well as "\n" for line feed and "\t" for tab. Any other control characters can also be entered with hexadecimal escape sequences like "\x07", but again keep in mind that these are only of use in certain places like Forms definitions. If you need to have a backslash character in the text and it happens to precede a letter that would normally make it an escape sequence (like "\r"), then you can force the backslash by using a double-backslash, e.g. "\\". Thus to enter the text "set\rreset", the expression "set\\rreset" would be used.

Also keep in mind the quote-nesting rules -- each layer of nesting will do escape sequence processing, so any backslashes used for escape sequences may need to be multiply-escaped. For instance to get a carriage return in a MessageBox message that's in quotes itself, duplicate the backslashes for each level:

```
EvalQ('MessageBox("Line1\\rLine2"))
```

Note: As a shortcut, text values can be "added" together (concatenated) using the plus (+) operator -- for instance: "Hello " + TextFunction() + " World".

Boolean values -- Also referred to as yes/no or true/false values. These are represented as the letter T or F with periods on each side (.T. or .F.). Keep in mind that this is also the way they would be displayed in a Query, for instance, if used as a raw boolean value. A simple way to convert these to Yes/No text is to use the **iif** function: **iif(value, "Yes", "No")** will return "Yes" if the value is true, "No" if it's false.

Date/time values -- There isn't a specific difference between date and time values -- technically one value contains both a date and a time. However the context in which it's used will determine whether the date or

time portion is of interest. To enter a raw date in an expression, enclose it in curly-braces: **{4/15/06}**. A raw date value will also be shown this way, but you can convert a date to text using **DateToText** function. Dates are the one exception to the operator-type-matching rule. Adding a number to a date is an easy way to add (or subtract) a number of days. For instance, $\{4/15/06\} + 10 = \{4/25/06\}$.

Record values -- This is a special value type, in that records only have an internal representation (they're essentially an internal pointer), and therefore can be part of an expression as a result of a function or as a variable. The only valid operators for records are the equal and not-equal conditional operators. One common operation is to test for a record being "null", e.g. to see if the ThisSite context is valid. This must be done using the **NullRecord** function, like: `ThisSite() != NullRecord()`. Note that if a raw record value is displayed, only its record ID will be shown with a "#" prefix (you may see this when testing an expression in the Expression Creator dialog).

Unknown values -- This isn't really a "type", but you'll see reference to this in some function definitions. For instance, the **Macro** function has an unknown return value type because the result type will not be known until the macro expression is executed. Of course as the creator of the Macro you should know what the result will be, but the expression parser won't know. This can cause a parsing error if it's in an expression where a known type is needed, such as an argument to a function or on either side of an operator. In this case, you'll want to use one of the single-letter type-casting functions to force it to be a known type: **N()** for numeric, **C()** for character, **D()** for date, etc. -- e.g. `N(Macro("MyMacro"))` if the macro is known to return a numeric value.

Date Formats

When using date values in curly-braces as shown above, the date must be in a recognizable format. There are a few different formats that are recognized, shown below.

Mon dd, yyyy - e.g. Mar 25, 2007 -- Month must be 3-letter English abbreviation

mm/dd/yyyy - (or d/m/y for non-U.S.) e.g. 3/25/07, 03/25/2007

Mon/dd/yyyy - e.g. Mar/3/2007

yyyy/mm/dd - e.g. 2007/03/25

yyyy/Mon/dd - e.g. 2007/Mar/25, Month must be 3-letter English abbreviation

Note that a dash or period (- or .) can be used instead of a slash (/), and that the day or month numbers can be with or without leading zeroes (e.g. 3 or 03). Except for the formats where the year is first, the year can be either 4 digits or 2 digits. Where the 3-letter month abbreviation is used, it can be upper or lower case, or mixed.

Expression Syntax Rules

Here are the basic rules for expressions:

- Function names are not case-sensitive (Today = TODAY)
- Function names must be immediately followed by the '(' character, with no space after the function name.
- There is no distinction between integer or floating-point numeric values. Internally they are all treated as floating-point, though some functions will only use the integer (truncated) portion.
- Parenthesis may be used around expressions to force the operator precedence.
- Anything not recognized as an operator, value or a function call is assumed to be a Variable, e.g. in $2 * R * Pi()$, "R" is assumed to be a variable.
- Spaces are not required around operators, values, or variables, but they are allowed (and recommended for readability).

- Text can be enclosed in single or double quotes (" or '). These can be nested inside each other to one level, if a function call requires a quoted expression (for instance, the following are OK:
Evalq("Evalq('Str(5)')") or **Evalq("Str(5) + ' this is a 5.' ")**, but this is not:
Evalq("Evalq("Str(5)")")
- If a quote is needed inside a text string, it can be escaped with a backslash: **"He said \"Hi\" to me"**.
- All expression elements have a result "type", e.g. numeric or text, and the result type is determined by the expression's final result. For instance, **2+2** is numeric, **2>2** is boolean, **"2+2"** is text. Some types cannot be mixed, e.g. **2 + "2"** is not valid, but numbers and dates can be added or subtracted: **{1/1/05} + 30** will add 30 days to the date 1/1/05.
- Any part of an expression not enclosed in quotes is parsed and evaluated, even if the result is not used. For instance in the expression **iif(2>3, 2+2, 2+4)**, all 3 expressions inside the **iif()** function are parsed and evaluated, even though the **2+2** expression is ultimately ignored. This is especially important when using functions which do things, like **SetFieldValue()**. You may not want it to "evaluate" all of them. This is where functions like **iifq()** come in handy, since the quoted expressions passed to it are just considered text except for the one that's used as the return value.
- There is no limit to the length of an expression or the levels of nesting, e.g. within function calls or parenthesis.
- There is a shorthand that can be used for some data field values, if used on the "Operational" record. For instance: **Resv:Resv_Type** is equivalent to **FieldText(ThisResv(), "Resv_Type"**). The shorthand versions are parsed slightly slower but are executed much faster. The Expression Elements dialog or Select Fields dialog will insert the shorthand version automatically when possible.

Expression Variables

You can pass information from one portion of an expression to another through variables. There are two types of variables: **Local** and **Global**.

A **Global** variable will retain its value as long as the program is still running, so it can be referenced later. These are useful for situations where you need to transfer a value from one area to another -- for instance to set a value in a menu that will be needed in a custom dialog later. Use global variables sparingly, since it can be difficult to keep track of them.

A **Local** variable only exists as long as you're within the same Expression execution cycle where it's created, or at any level of CallScript, Macro, Eval, etc. executed within that same Expression. So it's unique to that Expression -- e.g. a local variable created in a Query's Data expression will not exist for any other expression executed separately such as the Query's Filter expression (and thus will also not conflict with local variables by the same name in other Expression spaces).

Local variables are created with the **SetVar()** function -- they do not exist in the current expression's execution space before that. Within the **SetVar** function the variable name must be given as text, e.g. in quotes, like **SetVar("Index", 1)**. However when used in an expression, the name is not in quotes -- for instance: **ThisListRec(Index)**. See the Scripts section for more examples.

Global variables are created with the **SetVarGlobal()** function. The **SetVar** function can be used subsequently to change the value of the global variable, but this is not recommended (always use **SetVarGlobal** when possible just to keep it straight).

Note that a variable used in an expression must exist when an expression is parsed, or else a parsing error occurs. Note the difference between these two expressions, which both eventually execute the two expressions contained as arguments:

```
Eval( SetVar ("Index", 1), ThisListRec(Index))
EvalQ( 'SetVar ("Index", 1)', 'ThisListRec(Index)')
```

The first expression will result in a parsing error because everything is parsed at once, and the variable "Index" used in ThisListRec() does not exist until execution time.

However the second expression will work because the arguments to EvalQ are only parsed as text initially. During execution, the first quoted expression containing SetVar is parsed and executed, creating the variable, and then the next quoted expression is parsed while the Index variable exists (it's in the same execution space).

Important: Avoid duplicate names between global and local variables! If SetVar is used to create a local variable for the first time, and then SetVarGlobal is used to create a variable by the same name, the value of the global variable cannot be retrieved as long as the local variable is still in context (using a variable in an expression will always use the local variable if it exists, and it will check for global variables only if no local variable exists by that name). Likewise, using SetVar will always set the value of the local variable as long as it's still in context.

Here are the rules for using variables:

- Variables can be of any type. Once the variable is created, its type is set also (to the type of the expression used in the SetVar function).
- Variable names must start with a letter and may contain letters or digits. They are not case-sensitive.
- Global variables will retain their value system-wide, but can be overridden by a local variable created with the same name.
- Local variables are short-lived, generally only for the current expression or expressions evaluated therein.
- Any local variable that exists before a sub-expression is parsed and executed, such as in functions like CallScript, Macro, IIFQ, EvalQ, etc., is copied into the sub-expression and available therein, and its value is also copied back out.
- Any local variable that does **not** exist before a sub-expression is parsed and executed but is created within the sub-expression will be destroyed before sub-expression returns.
- These rules apply for any depth level of sub-expressions.

Expression Context

Expressions wouldn't be very useful if they operated in a vacuum, without any knowledge of what they're being used for. For instance on a receipt form, you couldn't use an expression to show the customer's name unless you know which customer you're printing the receipt for.

Expression "context" solves this problem by giving the expression processor as much information as possible about what the expression is being used for and what information is already known. This information is accessible through a number of "context" functions, or "This" functions.

The applicable information varies depending on the situation, but you can use the various "This" functions to get what's available. For instance in a list query's data expression, you can get the date range being requested for the query (**ThisFromDate** and **ThisToDate**), the base table of the query (**ThisTable**), and the specific record of the data line that the expression is being asked to fill (**ThisRecord**, or in some cases **ThisResv**, **ThisCust**, **ThisSite**, etc.).

Note that the **ThisRecord** function (or its short equivalent, **This**) is the generic form to get the current record in context. The record it returns could be any "type" of record, depending on the situation. This may be appropriate in general cases such as just checking for a valid record, e.g. **This() != NullRecord()**, or where there isn't a more specific function available. However in a case where you need a specific record type, such as a function to get a field from the record, you should use the more specific function like **ThisCust** or **ThisResv** whenever possible. This is especially true in Forms, where a single form may be useful in the context of Reservations, Customers, or even Sites. Using the specific context function allows you to easily create a copy of a Customer-based form and change the Base Table to "Reservations" so it can be used for reservations as well.

Refer to the applicable sections to find out which context variables are available in each situation.

Expression Processing

When an expression is used, there are two stages to its processing: Parsing and Execution. It isn't strictly necessary to know about this or understand it, but it can help in some cases to know the difference.

Parsing goes through the expression (which is actually just text to begin with) and converts the elements to an internal structure that's easy to execute. You might think of this as "compiling" in a language like C++ or Pascal. The syntax is evaluated for errors, function names are looked up, and it's converted to an operation tree.

Execution goes through the operation tree, calling any functions to evaluate the elements as needed, and evaluating the operators until it gets a single result for the expression.

In many cases, these simply happen one after another and it doesn't really matter whether it takes longer to parse or execute. However, in Queries where the program knows that the same expression is going to be needed many times (e.g. once for each record used in the report), it only parses the expression once. Then it does the execution of the expression many times, each time with a different record as the context record.

Sometimes you can use this to your advantage. For instance if you have a complex expression that involves some `iif()` conditions, you may not want it to execute both possible expression results in the function. In this case, it may work best to use the quoted-expression `iifq()` version. This will delay execution (and parsing) of the result parameters and only evaluate the one result that's needed.

Expression Errors

Whenever an expression is parsed or executed, error checking is performed. Depending on the function you're using, you may be able to see any errors encountered.

When using the Expression Creator dialog, you can "Calculate" the expression to check for basic syntax errors or other problems, to a limited extent.

When using the Save & Test function for Queries, Forms, Scripts, etc., any errors encountered may be shown as pop-up tips in a query or dialogs, or inside the form where the expression was to appear.

Expression Creator Dialog

The Expression Creator dialog is used in many places for entering expressions. It's invoked for "Add Expression" functions in queries, scripts, etc., and also available anywhere expressions can be edited.

In places where a dialog contains an expression editing field already, or shows an expression as static text, a button like "Test/Edit Expression" will open the Expression Creator dialog. Besides just a window for editing the expression, this has a few special functions to assist in creating the expression.

The Expression window acts like most other text entry windows, except that it also does some basic syntax highlighting. This colors the text according to the type of expression element. This happens dynamically as you type, as soon as the expression can be parsed into recognizable elements. The meaning of the colors is as follows:

- Black** -- Basic elements like math operators, variables and commas
- Green** -- Boolean operators (AND, OR, NOT)
- Dark blue** -- Numeric values
- Violet** -- Boolean values (.T. and .F.)
- Dark Red** -- Date values (eg. {1/5/2006})
- Bright blue** -- Recognized function names, once the parenthesis is present, like : Upper(
- Magenta** -- Text values
- Bright Red** -- Mismatched parenthesis, braces or quotes (can't find the matching one)

You can type and edit the expression manually, or you can also use the Insert Expression Element button to select functions and operators to be pasted into the expression. This will open the Expression Elements dialog (explained below). If you have anything highlighted in the Expression window, the highlighted text will be replaced with the element selected (a prompt will warn you that this will happen).

Once you have an expression entered, you can test it to a certain extent by clicking the Calculate button. (For that matter, you can use it as a fancy calculator this way). It will parse and execute the expression if possible. If there are no errors, the resulting value for the expression will be shown in the Result window. If there are errors, an Errors window will be added to the bottom and will list all errors encountered. If there are many errors, you can scroll to see the rest. (Often times one typing mistake will result in many errors as it continues to try to parse the whole expression.) Note that if the result is a record, the Record ID of the record will be shown (like "#000000002").

You can edit the expression and use Calculate as many times as you like. Once you're satisfied, click Save and the entire expression will be saved into whatever function you were editing the expression for.

Note that the Calculate function won't necessarily have all of the context information needed or variables defined to successfully execute the expression. If a base table is known, then it will use the first record in that table (e.g. the first reservation) as the operating record. Otherwise, most context information will not be valid for executing the expression here, which may result in errors even if the expression will work fine in its proper context.

Expression Timing

When you use Calculate, it will show the approximate time it takes to parse and execute the expression. If you're programming a complex report, this may help you make it more efficient by modifying the expression to execute more quickly.

Timing Tip: Most expressions take too little time to measure accurately just one time through. To get a better idea of the execution time, use the EvalQRepeatWhile function to make it repeat 100 or 1000 times. Note that the EvalQRepeatWhile function takes a quoted boolean argument and a count, so you need to modify the expression to be boolean (and always return True). One way to do this is to repeat the expression twice, once on each side of =, and use half the count. For instance, to measure the execution time of the expression Upper('abc') 1000 times, enter it like this (using a repeat count of 500 since the Upper() function is repeated twice in the expression):

```
EvalQRepeatWhile( "Upper('abc') = Upper('abc')", 500 )
```

Note that with the EvalQRepeatWhile function, the expression in quotes is only Parsed once. Only the Execute portion of the processing is done multiple times. For places like queries where speed is important, execution is the time that's most important anyway.

Expression Elements Dialog

The Expression Elements dialog is used to look up and select elements to insert in expressions. All available functions, data fields, pick lists, operators and other expression elements can be found here. This dialog is primarily invoked from the Insert Expression Element button on the Expression Creator dialog, but is also accessible from similar buttons on dialogs that have an expression editing window built in, such as Edit Query Column and Edit Macro Definition.

When inserting an expression element, remember that any text selected in the expression editing window will be replaced with the element you select here. A prompt will warn you of this, so you can go back and clear the text selection if necessary.

There are three lists in the dialog, which are used for looking up an expression element in a hierarchical fashion.

- First select the general kind of element in the first column, such as Function, Main Table Field, Pick List Value, Macro, or Operator.
- The other two columns will change depending on what you've chosen -- use the second column to narrow down your choice more, for instance by Function Type needed, or which Table you need the field for, or whether you need a Macro or Script, or which Pick List you need a value for.
- Thirdly, select the element in the third column, for instance the Field Name, Pick List Value, or Operator.

If you find what you need, then finally click the Insert button (or in some cases, Insert Numeric) to automatically copy the text or number shown into your expression. You'll notice when selecting an element that two windows will show information at the bottom. This information varies slightly depending on what kind of element is selected. Also note that what's actually inserted in the expression when you click Insert will depend on the kind of element.

Functions

All functions are shown by default (with "<All>" selected in the Function Type list), but you can narrow your search by selecting the Function Type of interest. Note that some functions will appear in more than one list, if it fits in more than one category.

The Return type and the Arguments needed for the function are shown in the first line, and a description of the function is shown below. Note that optional arguments are shown in brackets. These brackets may be nested -- for instance if it shows **nVal [nVal2 [nVal3]]**, that means the function could take one, two, or three values, and that nVal3 cannot be present without nVal2 also being present. As a general rule, arguments can never be skipped over -- to include an optional argument later in the list, all previous arguments must also be included.

When the **Insert** button is used to select a function for an expression, it inserts the function name and the required parenthesis, and also the argument list. This reminds you what arguments are needed, and then you can replace each argument as needed.

Note that the first letter of an argument indicates the type of argument needed (this is similar to what's called Hungarian notation, though it doesn't follow exactly the same rules as other programming languages).

- n = Number
- d = Date
- b = Boolean (true or false, specifically **.T.** or **.F.**)
- c = Character, or Text, e.g. in quotes
- e = Expression (may have various result types)
- r = Record of the database, like a Customer record

You may notice that there are some duplicate functions -- two different function names that do the same thing. The main reason for this is to provide shortcuts for some functions are used frequently. For instance, **ThisResv()** can also be used as **Resv()**, and **ThisRecord()** can also be used as simply **This()**.

A description of each function can be seen when the function is selected in the Expression Elements dialog, so the details are not included in this printed documentation. However you can find the details of all of the functions listed in the online Help (press the F1 key when you're in the Expression Creator or Expression Elements dialog, and you'll find a link to the Function Reference near the bottom of the help screen).

Main Table Fields

This shows the five main tables that are most likely to be used, and all fields for the selected table are listed (only the fields that are enabled). The fields are in alphabetical order by the Field Name (according to Data Field Definitions).

The field's Description will be shown in the line below the selection lists, and the large window will show the shortcut field identifier that will be inserted into the expression. This is a 4-letter table abbreviation and the field ID, separated by colons.

Important: The shortcut field identifier is only valid if the context of the expression will have a "This" field of the selected table type -- e.g. if the base table is Reservations, then "Resv" is valid. If the base table is Customers, then "Resv" is probably not going to work.

All Table Fields

This shows all tables in the database (excluding pick list tables), and all fields for the selected table are listed (only the fields that are enabled). The fields are in alphabetical order by the Field Name (according to Data Field Definitions).

The field's Description will be shown in the line below the selection lists. The large window will show what will be inserted into the expression when Insert is used. This is generally a **FieldText** function to get the text of that field, using **FindRecByRecID** function to get a record of a known Record ID. This is just an example -- many times you can replace TableRecAt with a more appropriate function according to the context (e.g. **ThisListRec**). You may also want to use FieldValue instead of FieldText. The important thing is that it gives you the field name and the table name if needed, so you know how to get that field.

Pick List Fields

This shows all pick lists in the database, and the "fields" available for the pick list selected. The fields are in alphabetical order by the Field Name (according to Data Field Definitions). Otherwise it works like All Table Fields above.

Pick List Values

This also shows all pick lists, but instead of showing the fields it shows the Selection Names of all of the current pick list items. This is generally used if you're creating an expression to compare a pick list field value to one of the items in the list.

The numeric value will be shown in the first line at the bottom (which is actually the pick list item's record ID), and the pick list text will be shown in quotes below that. The text in quotes will be inserted into the expression if you use the normal Insert button, but you might want to use the numeric value in some cases (it may be faster to compare values than text, and isn't as likely to change as the text). To insert the number instead of text, use the Insert Numeric button shown to the far right of the numeric value line.

Fixed List Values

This works like the Pick List Values, but it shows all of the selection lists in the program that can't be changed like the Pick Lists. The most commonly used of these are the Reservation Status and Transaction Types. You will often use the Insert Numeric button, since the most common functions referring to a fixed list will need the numeric value, not the text.

Macros & Scripts

This allows you to select one of the built-in Macros, or a Macro or Script that you've defined yourself. When a Macro is selected, the windows below show the description (as defined in the Macro), and the complete Macro expression. When a Script is selected, only the description is shown.

When one of these is Inserted, it will also include the "Macro()" or "CallScript()" function call with the Macro or Script name filled in. In the case of a Macro, it will also include place holders for any arguments needed for the Macro.

Operators

This shows a list of valid operators of the selected type, and will show a description of the selected operator. Inserting an operator simply inserts the operator, with spaces around it. Spaces aren't usually required, but it makes the expression easier to read.

Macros

Macros are single expressions that can be called by name from within any other expression, with optional "replacement" parameters. They allow re-using common expressions, or simplifying things by calling a complex expression inside another expression. They basically work the same way as macros in the C programming language.

Macros Setup

To create a Macro, go to Maintenance / Advanced Customizations / Macros. This opens the Macro Setup dialog, which lists all current user-defined Macros and allows the typical functions for adding, editing, etc. Note that while there are functions to Move Up and Move down, their position in the list does not affect any other functionality -- it's mainly for your own preferences. However if you have many Macros defined, it may help the speed of your expressions to put the most speed-critical ones nearer the top, since they are searched in this order when executing expressions.

You can also Export one or more Macros to a text file, or Import Macros. This is primarily for you to import Macros created by the software provider, though it can also be used to transfer Macros between multiple databases.

Some sample Macros are included with Campground Master which are actually used by the sample forms. While these have specific uses for the sample forms, you can also look at them as examples. Click the Import macros button, and you'll get a typical Windows file dialog labeled "Import Macros". You need to locate the samples folder, which is typically in **C:\Program Files (x86)\Campground Master\Samples** (most likely you just need to double-click the "Samples" folder to get there). Now select the appropriate "Sample Macro" file, and click Open. Once the sample is imported, you'll see it appear in the list.

Note that the import/export files use the "CSV" file extension (e.g. Sample.csv), which means it's a comma-separated-value text file. Windows may recognize this file extension as something another program can open like Excel, but these are in a special format for importing records to Campground Master and should not be used in other functions. Also avoid opening different kinds of samples which use the same extension (e.g. don't open a Form sample from an Import Script function).

Be aware that Macros should not have duplicate names (or else it would just use the first one encountered by that name). If you make a Copy, text will be added to the name to make it unique. If imported Macros have duplicate names, the imported names are automatically changed to avoid duplication. This might affect the expressions where the Macros are used, so a warning will be shown and indicate which Macro name(s) were changed.

Note that Macro names are not case-sensitive. "MyMacro" is the same as "MYmacro".

Editing Macro Definitions

When editing a Macro, a simple Edit Macro dialog is used where you enter the Macro Name (which is used to invoke the Macro in an expression), the Description (which is shown if the Macro is selected in the Expression Elements dialog), and the Macro's definition itself. Buttons are available to Insert Expression Element and Test/Edit Expression, which invoke the corresponding dialogs to help build the Macro expression.

The Macro definition is just like any other Expression, with one difference. A Macro can have "Replacement arguments", and there is a special placeholder format you use in the definition to indicate where these arguments will go. The format for the placeholder is **#n#**, where the 'n' is the argument number starting at 1. So you may have **#1#** and **#2#**, indicating the first and second argument to the Macro. Here's an example:

```
iif( VarExists('#1#'), SetVar('#1#', #1#+1), SetVar('#1#',0))
```

This Macro takes 1 argument, which in this case is a variable name. The expression increments the variable by 1, or sets it to 0 if it did not exist.

Using Macros in Expressions

To invoke a Macro, you use the function **Macro()**. Using the example above, assuming the Macro's name is "Inc", and the variable you want to increment is called MyVar:

```
Macro("Inc", "MyVar")
```

Note that the Macro name and all arguments must be text values. The argument's text that's inside the quotes, not including the quotes, will be inserted into the text of the Macro's expression, and then the expression will be executed. So in the above example, the Macro function results in this expression being parsed and executed:

```
iif( VarExists('MyVar'), SetVar('MyVar', MyVar+1), SetVar('MyVar',0))
```

There are a few important points to make about arguments for the Macro's expression:

- The Macro's expression, after replacing arguments, is actually parsed during the execution of the expression containing the Macro() function. This can greatly affect the speed of the parent expression.
- The replacement is strictly a text replacement, so the arguments can be anything -- an expression, a variable, or even an operator or function name. It can be any length, and could also be the result of another expression as long as it's a text result.
- Since the replacement may be done multiple times as in the example above, be careful what you use. For instance, don't use an argument that should not be executed more than once. Also keep in mind that it will need to be parsed many times (avoid huge expressions as arguments).
- Be careful about quotation marks in arguments, like " 'Text' ", if the argument is intended to be a text expression. While the example here is accurate for a text expression, the macro definition might also have quotation marks that conflict, creating an invalid expression (e.g. if the argument is enclosed in other quotation marks).

Macro Return Value

The "value" of the **Macro()** function will simply be the value of the executed expression, which can be any value type. If this is used within a more complex expression, you might need to use a type-conversion function so the parser knows what type it's supposed to return. For instance, if you know the Macro will return text but the parser gives an error that it's an unknown type, use the **"C"** function to force it to text form. For example: **Upper(C(Macro("MyName")))**

Macros can be powerful tools when used correctly, but it's best to use them sparingly in places where speed is important. You could still create the Macros as a handy reference for commonly used expressions, but then copy the text out of the Macro definition into the expression where it's needed, instead of actually "calling" the Macro, so it doesn't delay the parsing until execution time.

Scripts

Scripts are mostly a list of multiple expressions for performing more complex calculations, with a couple extra flow control capabilities built in. Scripts can be called like a function from another expression, so they're similar to defining functions in C or procedures in Visual Basic or Pascal.

If you just need to do simple iterations like adding up transaction amounts, or just need to execute a couple separate expressions at the same time, then you can probably do it without a Script by using the "Flow" functions like **LoopSum()** or **Eval()**. For more complex tasks, though, a Script will allow more flexibility and will also result in a little "program" that's easier to read and modify than a large expression.

In many cases, a Script might also be more efficient because its flow control allows skipping the parsing & execution of expressions that aren't used. So even though you could probably do the same thing with carefully nested **IIF** and **Loop** functions, they might not be as fast.

Scripts Setup

To create a Script, go to Maintenance / Advanced Customizations / Scripts. This opens the Scripts Setup dialog, which lists all current Scripts and has the typical functions for adding, editing, etc. Note that while there are functions to Move Up and Move Down, a Script's position in the list does not affect any other functionality -- it's mainly for your own preferences. However if you have many Scripts defined, it may help the speed of your expressions a tiny bit to put the most speed-critical ones nearer the top, since they are searched in this order.

You can also Export one or more Scripts to a text file, or Import Scripts. This is primarily for you to import Scripts created by the software provider, though it can also be used to transfer Scripts between multiple databases.

Some sample Scripts are included with Campground Master which are used by the sample forms. While these have specific uses for the sample forms, you can also look at them as examples. Click the Import scripts button, and you'll get a typical Windows file dialog labeled "Import Scripts". You need to locate the samples folder, which is typically in **C:\Program Files (x86)\Campground Master\Samples** (most likely you just need to double-click the "Samples" folder to get there). Now select the appropriate "Sample Script" file, and click Open. Once the sample is imported, you'll see it appear in the list.

Note that the import/export files use the "CSV" file extension (e.g. Sample.csv), which means it's a comma-separated-value text file. Windows may recognize this file extension as something another program can open like Excel, but these are in a special format for importing records to Campground Master and should not be used in other functions. Also avoid opening different kinds of samples which use the same extension (e.g. don't open a Form sample from an Import Script function).

Be aware that Scripts should not have duplicate names (or else the **CallScript** function would just use the first one encountered by that name). If you make a Copy, text like "(copy 1)" will be added to the name to make it unique. If imported Scripts have duplicate names, the imported names are automatically changed to avoid duplication. This might affect the expressions where the Scripts are used, so a warning will be shown and indicate which Scripts name(s) were changed.

Script names are not case-sensitive, so "My Script" will appear to be the same as "my script".

Editing Script Definitions

When editing a Script, an Edit Script dialog is shown with each line of the script (each line being a single expression), and also a place to enter the Script Name (which is used to invoke the Script in an expression), and the Description (which is shown if the Script is selected in the Expression Elements dialog).

Creating a Script is simply a matter of adding one line (expression) after another, just like writing a program. Of course you can Insert lines, move and copy lines, etc. as needed. Each time you Add, Insert, or Edit an expression line, the Expression Creator dialog is used. Thus you can test-calculate each line, look up functions, etc. like anywhere else.

Adding/Inserting Multiple Lines

Special functions are available [Add Multiple Lines](#) and [Insert Multiple Lines](#). These open a multi-line text window where you can enter as many lines as you want, all at once. This is usually faster than entering them separately, since you can work with several lines at once in free-form fashion. More importantly, it lets you copy/paste the lines from somewhere else, e.g. if you prefer using a different editor for programming. Just make sure that each expression has a "line feed" or "return" after it (long expressions will wrap but should not have the line feeds in them). Once you've entered or pasted what you want, click [Save](#). Each line will be added as a separate line, either at the bottom of the Script (for [Add](#)) or inserted above the line you selected ([Insert](#)).

Tip: If you have a bunch of lines in the script that need to be edited, select them all, use copy (Ctrl-C), click [Add Multiple Lines](#), and paste (Ctrl-V). Make your edits, Save, and then you can delete the originals and move the new ones into place.

Save & Test Script Results

This function simply uses the Expression Creator dialog, with a CallScript function already inserted to call the script you're working on. Press Calculate to execute the script to check for errors. Of course, like any other expression, it won't necessarily have all of the context information needed or variables defined to successfully execute the script, but you may be able to catch some of the basic problems with the script format, like mismatched IF/ELSE/ENDIF sets or WHILE/ENDWHILE pairs.

Using Scripts in Expressions

To invoke a Script, you use the function CallScript(). Note that the only argument is the script name itself (in quotes of course, since it's a text argument).

```
CallScript( "MyScript" )
```

Note: Script names are not case-sensitive. "MyScript" is the same as "MYscript".

There are no optional arguments available to be passed into the Script. If you need information passed into the Script, you can use variables (see below).

Scripts can be called within other Scripts -- even the same Script can be called recursively.

Script Return Value

Each Script has a single return value, just like any other expression (technically this becomes the return value of the CallScript function). To return a value from a script, simply make sure that value is the result of the last line of the script. Remember that script lines are just expressions executed one after another. So the "value" of the last line of the script will be the returned value -- often times this is simply a variable name, if the Script sets the variable to the desired value.

The return type can be any type of value. Note that if the Script is used within a more complex expression, you might need to use a type-conversion function so the parser knows what type it's expected to return. For instance, if you know the Script will return a number but the parser gives an error that it's an unknown or

mismatched type, use the "N" function to force it to text form. For example: **N(Script("JanReceipts")) + N(Script("FebReceipts"))**.

Script Variables

It was mentioned before that you can pass information into a Script using variables. You can also pass information out of a Script through variables, for instance if you need more than just the single return value. While using a Global variable is one way to do this, you can also do it with local variables (to keep the "context" more tightly controlled). Here are the rules for using local variables for Scripts:

- Local variables are created with **SetVar()** function -- they do not exist in the current expression's execution space before that.
- Local variables exist as long as you're within the same Expression execution cycle where they're created, or at any level of CallScript, Macro, Eval, etc. executed within that same Expression. They are unique to that Expression -- e.g. a local variable created in a Query's Data expression will not exist for any other expression executed separately such as the Query's Filter expression (and thus will also not conflict with local variables by the same name in other Expression spaces).
- Any local variable that exists before the Script is invoked with **CallScript** is copied into the Script, and its value is also copied back out (it can be changed inside the Script).
- Any local variable that does not exist before the **CallScript** but is created within the Script is destroyed before **CallScript** returns. It will exist for the life of the Script, since each Expression line is parsed and executed within the same execution space.
- These rules apply for any depth level of script calling -- e.g. every CallScript creates a new level of variable scope, with any existing variables copied into it and back out of it.

Script Flow Control

There are two directives available for flow control -- **IF** and **WHILE**. Script lines starting with these are specially handled (pre-parsed), not just executed as an expression. Any text following the IF or WHILE directive (separated by a space) is parsed and executed as an expression, and must have a boolean result value. The result of course determines whether the lines following the IF or WHILE are executed.

Both of these directives must be followed in the Script by a line containing **ENDIF** or **ENDWHILE**, respectively. In the case of IF, you can also have an **ELSE** directive before the ENDIF. There is not an ENDELSE -- the ENDIF is used to terminate both the original IF prior to the ELSE directive.

These may be nested to any level, but each directive set must be properly nested. Any directive set that's not properly nested will result in an error.

These directives are not case-sensitive (e.g. "if" or "If" may be used), but we suggest using upper-case for ease of script readability. See the examples below.

Indentation & Spacing

Leading spaces in front of any text in line are ignored, so you can put spaces in front of any expression (including comments and flow control directives). We recommend indenting each level of IF or WHILE nesting by at least 3 spaces to improve readability. You can also insert blank lines to separate sections. The excerpts below show a couple examples of nesting and the use of flow control directives, and comments in scripts.

```

SetVar( "nResv", NumTran( ThisResv() ) )
SetVar( "bFound", .F. )
SetVar( "r", 1)
; Verify that this reservation contains this transaction
WHILE r <= nResv AND !bFound
  IF ResvTran(r) = ThisTran()
    SetVar( "bFound", .T.)
  ENDIF
  SetVar( "r", r+1)
ENDWHILE

```

..... Here's an example of looping through all reservations in the database:

```

SetVar("nRec", 1)
SetVar("nRecs", TableNumRecs("Reservations"))
WHILE (nRec <= nRecs)
  SetVar("pRec", TableRecAt("Reservations", nRec))
  // .... do something with pRec, e.g. check last night....
  IF FieldDate(pRec, "Resv_Last_Date") = Today()
    MessageBox("Found one ending today!")
  ENDIF
  SetVar("nRec", nRec + 1)
ENDWHILE

```

..... multi-level IF/ENDIF nesting example:

```

IF CCNum != ""
  REM always need at least 2 lines
  SetVar("nLines", 2)

  IF C(Macro("TranCCAuth", "ThisTran()")) = "Y"
    SetVar("nLines", nLines+1)
  ENDIF

  // Need more lines if a signature is shown
  IF SettingLocalBool("Print", "PrintShowCCSigLine")
    SetVar("nLines", nLines+7)
  ELSE
    SetVar("nLines", nLines+2)
  ENDIF
ENDIF
ENDIF

```

Script Comments

It's a good idea to include comments in a complex Script, so you can understand it later. Any "expression" line starting with a double-backslash ("*//*") or a semicolon ("*;*") is considered a comment. You can also use "**REM**" like in Basic (there must be a space after "rem", but it doesn't have to be upper-case). Don't worry that you're using the same Expression Creator to enter comments -- just enter the text the way you want it as if it's an expression. A comment cannot be on the same line as an expression.

Function Reference

Function Types

In the Expression Elements Dialog where you can browse for functions and select the from a list, the functions are divided into several categories. This is simply to help narrow down your search -- there isn't necessarily a difference in the way each category is used. You'll also notice that some functions appear in more than one list, e.g. if their function involves more than one category.

Each category, or type, is briefly described below. The details of each function are not included in this printed documentation, but you can find the details in the online Help (press the F1 key when you're in the Expression Creator or Expression Elements dialog, and you'll find a link to the Function Reference near the bottom of the help screen).

Context (This...)

These functions are special in that the access values related to where the function is used. See the previous Expression Context section for more details.

Conversion

These functions are used to convert one type of value to another (e.g. numeric to text, text to date, etc.)

Database

These functions are used access any kind of database information (but not change it). In addition to accessing raw data fields, etc., many functions are included to get commonly needed information, for instance the current operator or the total amount due for a reservation.

Database Modification

These functions are used to modify the database. Naturally these should be used with care, since modifications cannot be simply undone, and anything modified through functions is likely to be done without the user knowing it has happened.

There is a subtle but important issue when changing database field values -- changes are queued up and "flushed" to the logs and to other workstations only when it expects changes, e.g. in data dialogs, when a change to an entry field is noticed. If you set fields through scripting, it won't flush those until the next time a "change" is noticed. Even inside a dialog, you need to make sure you use `DlgSetChangedFlag(.T.)` if you manually change data fields directly in a record, in case no other changes are made on the dialog entry fields that would normally trigger a flush.

Date & Time

These functions are related to getting the date or time, or manipulating date or time values.

Financial

These functions are related to financial operations, such as properly rounding or formatting amounts for your currency.

Flow

These functions allow you to conditionally execute other functions, thus they can be used to affect the "flow" of the expression.

General & System

These functions give you access to general information about Campground Master, or things outside of Campground Master such as Windows functions and files.

Inspection

These functions are used to "inspect" or "test" the results of an expression, generally for use in conjunction with Flow type functions.

Math

This function category includes anything related to basic mathematical operations.

Settings

These functions access or change program settings. While the settings are actually contained within the database, these functions are separated for convenience in looking them up.

Text

This category includes any functions related to manipulating text value types, for instance to extract parts of a text string.

User Interaction

Functions that involve some kind of interaction with the user are included in this category, such as showing message prompts or opening a particular user-interface dialog like Reservation Details.

User-defined Dialogs

All of these functions are specifically for use in Dialogs definitions, to access or manipulate the controls on a dialog (and to open a user-defined dialog).

FormatDateTime specifications

The cFormat argument consists of one or more codes; the formatting codes are preceded by a percent sign (%). Characters that do not begin with % are copied unchanged to the result.

FormatInt and FormatFloat specifications

The cFormat argument of FormatInt and FormatFloat can contain any text information along with one format specification for the number being formatted. Text not preceded by a % will be copied to the result as-is. For instance, to format currency and adding "US" in front of it you could use:

```
FormatFloat("US$ %.2f", 2.5)
```

This would result in: US\$ 2.50

Color Schemes

A Color Scheme is a set of rules used to determine the color of an item in a grid or an indicator on the map view. It can define the specific conditions for any number of foreground / background color combinations.

There are several places where color schemes are used. Primarily they're used for the color of data in Query columns, but they can also be used for special coloration of the heading rows or columns of Queries or on the standard tab views like the Rack. A color scheme can be used to add custom color combinations to the standard colors used on the Rack (and other tab views where a reservation name is shown), or on the Map.

Color Scheme Setup

To create a Color Scheme, go to Maintenance / Advanced Customizations / Color Schemes. This opens the Color Schemes Setup dialog, which lists all current schemes and has the typical functions for adding, editing, etc. Note that while there are functions to Move Up and Move Down, a scheme's position in the list does not affect any other functionality except for the order they will appear in selection lists -- it's mainly for your own preferences.

You can also Export one or more schemes to a text file, or Import schemes. This is primarily for you to import Color Schemes created by the software provider, though it can also be used to transfer schemes between multiple databases.

Some sample Color Schemes are included with Campground Master, which you can use or learn from (some may also be used in sample Queries). Click the Import schemes button, and you'll get a typical Windows file dialog labeled "Import Color Schemes". You need to locate the samples folder, which is typically in C:\Program Files (x86)\Campground Master\Samples (most likely you just need to double-click the "Samples" folder to get there). Now select the appropriate "Sample Color Scheme" file, and click Open. Once the sample is imported, you'll see it appear in the list.

Note that the import/export files use the "CSV" file extension (e.g. Sample.csv), which means it's a comma-separated-value text file. Windows may recognize this file extension as something another program can open like Excel, but these are in a special format for importing records to Campground Master and should not be used in other functions. Also avoid opening different kinds of samples which use the same extension (e.g. don't open a Form sample from an Import Script function).

Color Scheme Names

Note that Color Schemes cannot have duplicate names. If you make a Copy, text will be added to the name to make it unique. Color Scheme names are not case-sensitive.

Also note that even though Color Schemes are usually selected by name, for instance when defining a Query, the record link to the scheme is used to reference it internally. Thus you can change the names of schemes already in use without affecting any function that uses the scheme. However this also means that a scheme that's already in use (linked from a Query) cannot be deleted.

Editing Color Schemes

To edit a Color Scheme, use the Add or Edit functions in the Color Scheme Setup dialog. Other functions where schemes are referenced, such as the Global Color Schemes function, have buttons to directly edit the scheme without leaving that function and going through Color Scheme Setup.

When editing a scheme, an Edit Color Scheme dialog is shown with each Color Rule of the scheme (each rule being a single expression and the colors represented), along with a place to enter the Color Scheme Name, and an optional Default Scheme.

Creating a Color Scheme is simply a matter of adding Color Rules. Of course you can Insert rules, move and copy rules, etc. as needed. When a rule is Added or Edited, the Edit Color Scheme Rule dialog will be used to enter the details.

Default Scheme

The Default Scheme is used to help define how the color scheme will be used. Think of it as an add-on scheme to either Reservation colors, Open Site colors, or a standalone scheme ("None" for the default).

If you're creating a color scheme to be used for reservations on the Rack, for instance, select "Reservations" as the default scheme. It will not only have the Resv() context available for your rules expressions so you can check reservation conditions. Also, after checking the rules in your scheme, it will also use the colors already defined in the Reservation Color Key for any conditions that don't match one of your rules.

If you're creating a color scheme to use for open (unoccupied) sites on the Rack, select "Open Sites" for the default scheme. It will make the Site() context available, and check the open site colors after checking your rules.

The "None" default scheme would be used for special case colors, for instance in coloring a special column on your own Queries, or for other Rack headers like the Site Abbr headers. The appropriate Site() context will be available when needed.

Quick-add Resv Type

If you've selected "Reservation" for the Default Scheme, this button is available to easily add a complete color scheme setup for a new reservation type. Just click that button and then select the Reservation Type you want to create a scheme for. It will automatically add all of the Color Rules needed to override the normal reservation colors with new colors for that reservation type. The number of rules will depend on the Base Type of the reservation type selected -- for instance, Normal-based types have a lot more conditions than Guest-based types. All you need to do is edit each rule and change the colors to your liking.

You can use this any number of times in the same Color Scheme, to add rules for all of your new reservation types. Just be sure to avoid adding multiple rule sets for a single reservation type -- it won't necessarily hurt anything, but only the first set would apply, and the extras would just slow things down.

Quick-add dates

This option will be available if you select "Open Sites" or "None" for the Default Scheme. This is useful for creating a scheme for Holiday dates, for instance. Just enter all of the applicable dates or date ranges that you want the scheme to apply to. A color rule will be added with the appropriate condition expression for those dates. Note that it will be using ThisDate() for the context, which should work for most uses of this (e.g. as color schemes for open sites on the Rack or for the Date headings). If the Default Scheme is "Open Sites", it will also include the condition that the site is open and available (normally white, for instance). If you need a special case, like overriding the color even if the site is marked unavailable, for instance, then it would be up to you to modify the condition.

Editing Color Rules

The Edit Color Scheme Rule dialog is invoked from Edit Color Scheme, when adding or editing rules.

Here you enter a Name for the rule, select the foreground and background colors to be used, and enter an Conditional Expression which defines when the rule is to be used. You can type the expression directly in the dialog here, or use Insert Expression Element to select and insert elements as needed. You can also use

Test/Edit Expression to open the Expression Creator dialog. The Expression Creator has basically the same functions as the Color Rule dialog, but it also has the Calculate function for testing the expression.

Note that the Name should be as descriptive as possible, explaining what that color rule specifies. If this Color Scheme is used as a Global Default Scheme for reservations or maps, then the name of each rule will be shown in the Color Key list.

You'll notice that each rule has both a foreground and a background color. You can't just define a rule for the foreground, e.g. to make any unpaid reservation have red text. You must define rules for every possible combination of colors (at least any that won't be covered by the scheme's "Default scheme").

How Color Schemes Work

When a color scheme is used for a data element, the program executes the Condition Expression for each Color Rule in sequence. If the expression results in a True (.T.) value, then the color combination selected for that rule is used. No further rules are processed for that data element. If the expression results in a False (.F.) value, then it continues checking the following color rules until a True value is found.

If none of the rules result in a True value, then it checks for a Default scheme. If a Default scheme is defined for the Color Scheme, then that will be used to determine the data color. If not, then the program will probably use whatever default is normally used for the data (e.g. as if no color scheme was specified). If you want to specify your own default color so that it never uses the program's default, then add a rule to the end with just ".T." (without the quotes) as the Condition Expression. That will force the last color to be used (since the condition is always True), if none of the previous colors apply.

Functions for Color Scheme Expressions

The context is important in most color schemes, since that's usually the basis for the color rules. For instance, if the scheme is to be used for coloring Reservations, then the **ThisResv()** context function will be heavily used in the scheme's rules. The context functions **ThisCust()**, **ThisSite()** and **ThisPark()** would also be available. If it's a scheme to be used in a Transactions query, then **ThisTran()** is also available.

The date can also be important for color schemes, e.g. to show on the Rack whether it's paid up to the given date (and scheduled Period if applicable). The context functions **ThisDate()** and **ThisPeriod()** are used to get the specific Rack column date other date of interest, for instance the "as-of" date on Payments Due.

In some cases, such as the data color schemes for Cross-table Queries, other context functions are available to get the appropriate information such as **ThisValue()** or **ThisGroupText()**. See that section for more details.

There are also some special functions that can be useful in color schemes. Remember that each rule needs to check for a precise condition for the color combination of interest, and yet those conditions should be unique enough not to use the color for the wrong things. For instance if you want to define a special color for Hourly reservations, you need to do much more than just check the Reservation Type field. You would probably want several color rules like there are for other types, to indicate different status for hourlies like pending, confirmed, guaranteed, checked in, etc. You should also make sure these colors don't accidentally apply to special cases like conflicting, canceled, checked out, etc.

So you can see that the expression for a rule might need to check quite a few things, which not only takes your time to create the expressions for but also slows down the processing of the rules. Therefore some shortcut functions have been added to get a value for the "default" color status that would otherwise be used for Reservations (**ColorStatusResv**), Map sites (**ColorStatusMapSite**) or Rack sites (**ColorStatusSite**). These return a numeric value based on one of the color-status values in the default color keys, which you can use in a Color Rule expression to determine what color would normally be used.

To get the values returned for each function, go into the [Insert Expression Elements](#) dialog, select "Fixed List Values", and select either "Site Status (color default)" or "Map Status (color default)". When a status is selected in the last column, its numeric value will be shown in the box below.

So now you can create a rule that overrides a normal color with an expression that compares the normal status and your specific condition, rather than an expression that has to check several different things. For example to override the "Resv., Pending, Don't Move, Paid" color for normal reservations to be a different color for hourlies would normally require checking at least 5 different fields for the precise condition, but you can do it with this expression:

```
ColorStatusResv( Resv(), ThisDate(), ThisPeriod() ) = 37
AND ResvBaseType( Resv() ) = "Hourly"
```

Note that the expression above is shown on two lines for clarity -- the expression itself should not be broken into two lines, but of course it may wrap automatically in the dialog's edit box.

For site-based color schemes for instance on the Rack (particularly if used for a Default Global Color Scheme), use **ColorStatusSite**. This will return one of the "Site Status" colors for the reservation(s) on the site if applicable, or the open site, for the given date and period. For a color scheme that's to be used only on a Reservation-based Query, you can use **ColorStatusResv** to get the status of a reservation as of a particular date (which may affect paid/not-paid, etc.).

If you create a color scheme to be used as the default on the Map view, use **ColorStatusMapSite** so that it handles the special map coloring for the site (and also provide the date arguments for the map range, which will be available in the context functions **ThisFromDate** and **ThisToDate**). If you're trying to color the open sites according to an attribute, for instance, be sure to have the expression check that the site would normally be shown "open" for the map as well as for the attribute. For instance to have a color rule that highlights 50 Amp sites in a different color, use the expression:

```
ColorStatusMapSite( Site(), FromDate(), ToDate() ) = 1 AND Campsites:Attrib_50A
```

Note that a Color Scheme to be used for the Map's Default Global Color Scheme does not need to have a "Default scheme" -- it's assumed to use the Map's normal colors by default.

Default Global Color Schemes

This function is accessed through Maintenance / Advanced Customizations / [Select Global Color Schemes](#). Here you can select a custom color scheme to be used by default for Reservation coloring, Map indicator coloring, open sites on the Rack or the various Rack heading rows and columns.

While this isn't the normal place to set up Color Schemes, you can use the [Edit Scheme](#) buttons to edit any selected scheme or to create a new one (if no scheme is currently selected).

Note that the color scheme selected here for the Reservations override will be used on the Rack (for sites occupied by a reservation) as well as on the other tab views where the customer's name is shown. It will also be used on the Map view if the "Use reservation color coding" option is selected there. In other words, it's used anywhere that a reservation is typically shown in a color to indicate its status. Any color scheme used for this should have "Reservations" selected as the Default scheme. In addition, the Color Key function will include the colors from the scheme, and also allows editing the colors (or the entire scheme) directly from the Color Key dialog.

The Rack headings color scheme selections can be used to override the normal static heading colors on the Rack. This can be used for instance to show the Site names or Types in different colors depending on their status, Park, or any attribute. Any scheme for site headings or open sites will use the context function **ThisSite** available, which can be used in the expressions to get the appropriate site information.

You could use a color scheme on the date headings to highlight certain days of the week, holidays, or any special situation. A special color scheme can also be used for any open sites on the Rack, for similar reasons or to indicate something about the site. There is a special context function, **This Date**, which indicates the date of the cell or heading of interest in these schemes. Here's a simple example of an expression which can be used in a Color Rule to change the color of the header for Saturday and Sunday:

```
DoW(ThisDate()) = 7 OR DoW(ThisDate()) = 1
```

Note that the default color scheme selections are also global in that they affect all workstations.

Queries

Overview

Queries are at the core of most reporting functionality. At the most basic level, a Query is defined as a data filter and a number of data extraction (field selection and formatting) specifications. In Campground Master, a query is typically represented by a grid with data in it.

Any of the Tab views (except the Map view of course), and just about every report or grid view available in Campground Master could be considered a Query even though they're built-in functions. Although these are programmed internally for the benefit of speed, you could reproduce any of them using the Query definition functionality. In some cases you may want to do just that, with minor modifications to suit your own specific needs. However if it's one of the Tab views you want to modify, there's no need to recreate the whole Query -- just create a Query with the special information columns you need to add on to the standard columns available, and select that Query as an Add-on Query in the Tab's Option function.

When any Queries are defined, you may also have a Query Tab view. Here you can select any query to be shown on the Tab, and optionally select start and end dates for filtering and possibly enter search text to use in the filtering (making it a kind of "Find" function).

Query Types

There are two general types of Query in Campground Master -- List Queries and Cross-Table Queries.

A **List Query** is like the Arrivals Tab View -- it's a list of records (specified by a filter definition) and a number of Query Column definitions which specify what fields or calculated information to show for each record. The column definitions can include custom formatting and color coding by Color Schemes (including the headings), and custom sorting rules. You can also select an expression to be shown for a pop-up tip (when the mouse is held over a cell), as well as a double-click action. This makes them interactive, and thus more useful than just a static report.

A **Cross-Table Query** is like a Transaction summary report or the Rack view -- it's also generated from a list of records, but instead of showing a single record in each row (with various details in each column) it shows calculated information in a cross-table, where the records used for the calculation of each cell of the table are filtered by two additional conditions -- one for rows and one for columns. You can specify nearly any kind of grouping you want for both the rows and the columns, making it easy to cross-correlate information in various combinations. This allows for much more creativity than just showing information by date.

Queries Setup

To create a Query, go to Maintenance / Advanced Customizations / Queries. This opens the Queries Setup dialog, which lists all current Queries and has the typical functions for adding, editing, etc. Note that while there are functions to Move Up and Move Down, a Query's position in the list does not affect any functionality other than its order in drop-down selection lists. This of course may be important to you for organizational purposes.

You can also Export one or more Queries to a text file, or Import Queries. This is primarily for you to import Forms created by the software provider, though it can also be used to transfer Forms between multiple databases. Note that the Export and Import functions will also Export or Import any Color Schemes used in the Query definition.

Queries cannot have duplicate names (or else they could not be uniquely selected from a list). If you make a Copy, text like "(copy 1)" will be added to the name to make it unique. Of course you can change this to something more appropriate. Duplicate checking for the names is not case-sensitive ("My Query" is considered the same as "my query").

When you Add or Insert a query, you will first be asked what kind of Query you want. This is because the editing of each type is quite different. Once you select the type, it will continue to an editing dialog for that type -- either for a List Query or a Cross-Table Query.

Importing Sample Queries

Several sample Queries are included with Campground Master which you can use as reports, learn from, or modify as needed. To use these samples, you must first Import them. Click the Import queries button, and you'll get a typical Windows file dialog labeled "Import Queries". You need to locate the samples folder, which is typically **C:\Program Files (x86)\Campground Master\Samples** (most likely you just need to double-click the "Samples" folder to get there). Now select the appropriate file, for instance "Sample Query - Rent Roll" to get a Rent Roll example, and Open.

Note that the import/export files use the "CSV" file extension (e.g. Sample.csv), which means it's a comma-separated-value text file. Windows may recognize this file extension as something another program can open like Excel, but these are in a special format for importing records to Campground Master and should not be used in other functions. Also avoid opening different kinds of samples which use the same extension (e.g. don't open a Form sample from an Import Script function).

When you're importing sample Queries, it may also import Macros or Scripts that are used in the Query. If these are already defined, resulting in a duplicate name, then a warning will be shown listing the duplicates and what their names were changed to during the import. These might be safe to delete, assuming the imported version does the same thing as the original version. Otherwise you will need to change any expressions in the Queries that use the Macro or Script so that it uses the correct name.

Once the sample is imported, you'll see it appear in the Queries list. You can Edit the Query to make any changes you need.

Editing List Queries

The Edit List Query Definition dialog is shown when adding or editing list queries from Queries Setup. Other functions where Queries are referenced, such as the Queries Tab view, may also have a button to directly Edit the Query without leaving that function and going through Queries Setup.

Here you can edit all of the components of a List Query. There are a few fields you can edit directly, a couple of buttons for editing the list of Default Sorting and Filter Conditions for the Query, and the main portion of the dialog for editing the "meat" of the Query -- the Query Columns. The order of the columns is also defined here, by their order in the list, which can be adjusted easily with the Move Up and Move Down buttons.

Query Name

The name should be descriptive enough for selecting the Query out of a drop-down selection list. Queries will usually be shown in the order they appear in Queries Setup, not alphabetical, so the name doesn't affect the order. Each Query must have a unique name (which is not case-sensitive).

Base Table

The base table determines the primary data table of the Query -- that is, which records are potentially going to be included in the Query. For instance, if the base table is Reservations, then the Query will include all Reservation records by default, subject to the Filtering Conditions.

Selecting the base table is important, but it's not always an obvious choice. For instance, let's say you want a list of outstanding balances. If you choose "Customers" as the base table, then you could easily show customer balances but it wouldn't be as easy to show reservation information (site or in/out dates, for instance), and the balance might not represent a current reservation. If you choose "Reservations" as the base table then you can show each reservation with a balance, and any related information, and it would show multiple lines for the same customer if they have more than one site reserved (e.g. linked reservations).

Also keep in mind that the base table affects which context functions are available for Query expressions. If "Customers" is the base table, then only ThisCust is useful (because a Customer record doesn't necessarily have a unique reservation). If "Reservations" is the base table, then you can use ThisResv, ThisCust, ThisSite, and ThisPark, because all of that information is known for each reservation.

Another function of the base table selection is to determine where a Query is appropriate. For instance, Query must have a base table of Reservations to be added to tab views like Arrivals, Departures, etc., and a base table of Transactions to be added to the Transactions tab view. It must have a base table of Sites to be added to the Rack sites headings.

Any table in the database may be selected, but only a few are useful for most situations -- Reservations, Customers, Transactions, and Sites.

Note that if you're creating a Query to use with the date headers of the Rack, then the base table does not matter since no record information is used. However for testing reasons, we suggest using Parks just because the Save & Test function will try to show all records of the selected base table, and the Parks table usually only has a few records.

Access Level

The access level simply determines which operator access level is required to view the Query. If the current operator does not have the selected access level, then the Query will not be shown in the selection list on the Queries Tab view, for instance.

Exclude from Lists

When this is checked, the Query will not be shown in any selection lists such as in the Queries Tab view. Note that this does not actually disable the Query -- e.g. if it was already selected as an add-on for a tab view then it will still be used in that function. However it won't be available as a general selection, which can be handy for keeping special-purpose Queries out of view. Of course this also means that you would need to uncheck this again (temporarily at least) if you ever did need to select the Query somewhere. Another alternative would be to set the Access Level for such Queries to Administrator, assuming that most operators are non-administrator.

Note that one place that Exclude from Lists does not affect is the Tab Views Setup (since this is assumed to be an administrator-only function anyway).

Default Sorting Hierarchy

The default sorting hierarchy is used as the lowest-order sorting when any column is sorted in the query, if the specific column sorting results in equal values.

For instance, if a Transactions-based query is sorted by Site, you may have a lot of records with the same Site. The normal Site column sorting would consider these equal, so the order of those records of the same site could be random. However if you've specified a default sorting hierarchy, then it would be used to further sort those records of the same site -- in the case of Transactions, we suggest using a default hierarchy that includes the Date, Time, and Record ID fields of the transactions, in that order.

Filtering Conditions

The filtering conditions determine which records of the Base Table are included in the Query. Without any filtering conditions, ALL records are included (which in some cases is what you want, e.g. to include all Sites). Refer to the Filter Conditions section below for more details.

Important: If this query is selected as add-on for another Tab View (e.g. Arrivals), then any filtering conditions defined here are also used to determine which records are shown. Only records that pass the filtering here **and** the tab view's normal filtering will be shown.

Includes Text Filter

When this option is checked, the user will have the option to enter search text. You should include a filter condition that checks this text against the appropriate field, e.g. a customer name, site number, confirmation number, etc. This allows you to create any type of "Find" query you can think of.

Query Columns

This grid simply shows the "columns" of the Query (although the end use may not be columns, such as when used as a date header add-on Query for the Rack). The order of the entries here determines the order of the columns when the Query is used. While only the column heading name and expression is shown here, there is actually much more information in a column definition. Each column is actually a separate Query Column record, linked to the Query.

Typical functions are available for adding, inserting, copying, moving, and deleting columns. When adding or editing a column (double-click on a column also edits it), the Edit Query Column dialog is used to enter or edit the information for that column.

Quick-Add Fields

This is a special function for quickly adding simple data fields to a query. It displays a dialog where you can select one or more fields to be shown in the Query. You can choose fields from any table that will be appropriate, e.g. any table that will be available in the context of the query.

To add a field, just double-click the field name in the left column (or select the field and click the "-->" button). To remove a field, double-click it in the right-hand column, or select it and click the "<--" button. If you don't add them in the right order, don't worry about it here -- you can fix the order once you're done and get back to the Edit List Query dialog (using the Move functions).

For each field added, a Query Column record is created and added to the Query. The various details of the column, such as the heading, expression, justification, formatting, summing and sorting details are all set up with appropriate defaults. If these aren't quite what you want, you can edit the columns added, just like any other column.

Save & Test Query Results

This function invokes the Save & Test dialog, which shows the Query in a grid. This can be used to test the query, without completely exiting the Edit function. Be aware that it **does** completely save any changes you've made to the Query, so it negates any possibility of cancelling changes you've made.

Notes

You can enter any notes for yourself here, or use this as a description of the Query -- they're only seen here and in the list in Queries Setup.

Editing Query Columns

The Edit Query Column Definition dialog is only shown when you Add, Insert or Edit a column from the Edit List Query dialog. Here you can change any of the details of the query column.

Field / Expression

This expression defines the content of this column for each record of the query. You can enter the expression directly in this editing window, or use one of the helper functions above it. Buttons are available to Insert Expression Element and Test/Edit Expression, which invoke the corresponding dialogs to help build the expression. There's also an Insert Field button, which invokes the Select Data Field dialog. Here you can simply select a table and data field, and the expression and other formatting information will be automatically filled in with some appropriate defaults.

Column Heading

This will be the name of the column and the text in the heading. This field can't be blank, but it's OK to have duplicate names if you really want to. Keep in mind that the columns will auto-size to fit the widest thing in them, whether it's the heading or the data. So if the data is typically short, like a number, then you'll probably want to keep the heading short too. It's also possible to have multi-line headings to keep the width smaller. Do to this, insert the \n line break escape, like this: `Item\nQty`

Custom Colors for Column Heading

If this option is checked, you can select custom text and background colors for the heading. This isn't commonly used, but you might want to use it to highlight a column for some reason. An "Example" box will show the current colors, and the "Text" and "Background" buttons are used to pick the desired colors.

Data Color Scheme

If you want to use something other than the default Windows colors for the data in the column, then you need to use a Color Scheme. Appropriate context will be available in the color scheme, such as the record being shown and the from/to dates selected for the Query. Thus you can create a color scheme that colors the data according to content or anything else about the record being shown.

If you haven't created the color scheme you need yet, or if you find that adjustments to the color scheme are needed, then you can use the Edit button next to the color scheme selection list.

Tip: If you just want to use the normal Reservation color coding like the other tab views do, then create a Color Scheme that has "Reservations" as the Default scheme. No rules need to be added to the scheme.

Show Group Totals

If this box is checked, then the "totals" will be calculated for the column and shown at the bottom. If there are blank lines inserted in the query due to sorting groups (see "Blank lines..." below), then sub-totals will also be inserted in those blank lines.

The calculations for the totals shown can be a Sum, Average, or Count. Sum is obviously just the sum total, Average will divide the total by the number of records involved, and Count will simply show the number of records.

Tip: To get a total number of records at the bottom like you see on most tab views, check this box for the first query column and select "Count" as the totaling method.

Format

This determines the format of numeric values, assuming the expression results in a number. For non-numeric data, the "General" option should be chosen. For numeric data, select an appropriate format, e.g. Currency, Integer, Percent, or Floating Point. If none of these quite fits your needs, then you can select Custom Format and enter an expression to format the data any way you need to.

Note that technically you could format the data in the Field/Expression itself, for instance by using "Currency(Tran:Tran_Amount)" instead of just "Tran:Tran_Amount". However this would not allow the values to be totaled since the expression no longer results in a numeric value.

The Format specification also determines the format of the total and sub-totals, if the Show Group Totals option is selected.

Custom Format Expression

This field only appears when the Format selected above is "Custom Format". To edit the format, click the Edit button or simply click on the text box below it. This invokes the dialog to edit the format expression.

For the most part, the format expression should simply convert a numeric value to text. The numeric value to be formatted will be available with the context function **ThisValue**, which will already be shown in the expression the first time you edit it. There are several functions available for formatting numeric values. For a simple example, lets say that we want to take the number and show it as a currency value rounded to the nearest dollar. The expression entered would be:

```
Currency( Round( ThisValue(), 0))
```

Technically you can do anything you want in the format expression -- the context will also have the record of interest and the from/to dates of the query. So the format could even include other fields of the record.

Remember that the format only affects the way that the number is displayed, not the way it's sorted or totaled, which is why you would do the formatting here instead of in the main Field/Expression for the column.

Align Text & Heading

Select the desired alignment, or justification, of the data (text) and the column heading. Typically the heading is always centered, but there may be cases where you want it left or right justified.

Sort this column by default

When you want a specific column in the Query sorted when it's initially displayed, check this box for the column to be sorted. If no columns have this checked, then it will be sorted by the first column. You can also select the direction of the sorting, ascending (lowest on top, highest on the bottom), or descending.

Only one column in the Query should have this option checked (if more than one column does have it checked, the first column found will be sorted).

This does not affect the method used to sort the records -- it will be the same as if the column header is clicked to sort the column.

Blank lines between sorted groups

If this box is checked, and if the query is sorted by this column, then blank (non-record) lines will be inserted between any *different* values. This is similar to the Transactions detail view, where blank lines are inserted when it's sorted by date, type, category, etc. Only one blank line can be inserted between each different value, no matter how different they are.

Note: When deciding whether the values are different, **only** the result of the Field/Expression for the column is used. If a special sorting hierarchy is defined for this column, or a default sorting hierarchy for the Query is defined, it may affect the order of records within a "group" but it will not cause extra blank lines to be inserted.

When blank lines are inserted, any columns with the Show Group Totals option will also have sub-totals inserted in the blank line.

Pop-up Tip Expression

If you want something to appear in a pop-up hint whenever the mouse cursor is placed over this column, then you can enter an expression here. To edit the tip expression, click the Edit button or simply click on the text box below it. This invokes the Expression Creator dialog to edit the tip expression.

The result of the expression should be a text string to be displayed. Typical context will be available for the record underneath the cursor, so the expression can use fields from the record being shown, or any other information.

Note that the pop-up tip can only be a single line, so be careful about its length.

Double-Click Action Expression

This can be used to make something happen when this column is double-clicked on. To edit the expression, click the Edit button or simply click on the text box below it. This invokes the Expression Creator dialog to edit the expression.

This expression could be anything from showing a message box with information about the record to executing a Script performing all kinds of functions, even changing the values of fields. For instance, you might have a "Clean" flag defined for Sites, and make double-click change the flag back and forth between "Yes" and "No". Just be careful about doing things that can't be easily undone, since a double-click might be accidental.

Special Sorting Value/Hierarchy

This allows you to change the way this particular column is sorted, for instance when the header is clicked on to sort it. This is a list of expressions used for sorting, the same way the Query's Default Sorting Hierarchy works, but is only used when this column is sorted rather than for all columns. Any current sorting expressions are shown in a list. To edit the sorting expressions, click the Edit Special Sorting Value/Hierarchy button.

By default, the column will sort based on the result of the main Field/Expression -- so that result is compared directly for each record, whether it's a numeric, text, date, or boolean value. If this doesn't result in a reasonable sorting, then enter special sorting expressions to sort the way you want. If any sorting expressions are entered here, the Field/Expression for the column will not be used at all for sorting.

The most common value needing special sorting is the Site name or abbreviation. Sorting by the text of the site name will rarely result in the order you want. In this case, you actually want to sort by their record order, that is the order they have been set up in the Sites data table. Therefore you would use this expression for sorting a Site column:

```
SiteOrder( Site() )
```

Another common issue is upper-case and lower-case values, since "Smith", "SMITH" and "smith" would all be considered different when compared directly. For this you would want to convert them to all upper-case and sort that way so they're all considered the same, without actually changing the data shown in the column. This would be done using the Upper() function -- see an example in the next section, Sorting Hierarchies.

Sorting Hierarchies

The Edit Sorting Hierarchy dialog is used to enter one or more expressions to determine a sorting order of records, for instance in Queries. Each expression is shown in a grid, with the typical functions to Add, Edit, Copy, Delete and Move the expressions.

Since the expressions are used in the order shown here, the order of expressions in the list determines the sorting hierarchy. In other words, the first expression is the most important and is compared first, and if that still results in equal values then it will compare using the next expression, etc.

There will be appropriate context information for each expression, since the expressions are used to compare specific records or other specific information to be sorted. The exact nature of the context will depend on where the sorting hierarchy is used, but for instance if it's the default sorting hierarchy in a Query with a base

table of Customers, then the context function **ThisCust** will be available (or the generic version, **ThisRecord**, can also be used).

When sorting is done, it actually executes each expression twice (once with the context of each record to be compared), and then compares the results. Therefore the expressions can result in any type of value -- text, numeric, date, etc. -- the program will know how to compare them. You don't have to actually do the comparison in the expression, just make the expression be the values to be compared.

Lets say we have a Query with the Reservations base table. To have a default sorting of customers by last name, and then secondarily sort by first name if the last names are the same, and a third level of sorting by the number of nights in the reservation (if the same customer), the sorting expressions would be:

```
Upper( Cust:Cust_Last_Name )
Upper( Cust:Cust_First_Names )
Resv Nights( ThisResv() )
```

Note that we used the Upper() function on the names so that it doesn't matter whether the names are upper or lower case (or mixed-case). Also note that the shorthand field descriptor is used (e.g. Cust:Cust_Last_Name) instead of a function like FieldText(ThisCust(), "Cust_Last_Name"). The shorthand should generally be used everywhere possible, since it does more work during parsing and less during execution

Filter Conditions

The Edit Filter Conditions dialog is used to enter one or more filtering expressions for Queries. Each expression is shown in a grid, with the typical functions to Add, Edit, Copy, Delete and Move the expressions. Since the expressions are used in the order shown here, this can be a speed consideration but otherwise is not an issue (see below).

Filtering conditions determine which records of a Query's Base Table are included in the Query. Without any filtering conditions, ALL records are included (which in some cases is what you want, e.g. to include all Sites).

Each filter condition is an expression that results in a boolean value (True or False). It's important to remember that **all** of the conditions must be "met", or "True", for a given record to be included in the Query. When filtering a record for the Query, each expression is executed in the order specified, until a False condition is found. If no condition returns False, then the record passes the test and it's included in the Query. If a False is found, it stops executing filter expressions (to save time) and the record is not included.

The most common elements of the filter conditions are the context functions for the data range that the user selects for the Query (e.g. the From and To dates on most Tab views). For instance, in a Reservation Query you can include only Reservations that exist in the date range with the following filter condition:

```
Resv:Resv_Last_Date >= FromDate() AND Resv:Resv_First_Date <= ToDate()
```

This is just like the On Site view date filtering. By changing the Last or First date fields, you can change it to include reservations arriving or departing on the selected dates. Similar filtering would be done for Transactions using the **Tran:Tran_Date** field descriptor.

Other common filter conditions would be for including only active reservations (using the **ResvsActive** function), including only checked-in reservations (using the **Resv:Resv_Status** field descriptor), or including only reservations on a site (using the expression **Site() != NullRecord()**).

Quick-Filter Auto-Builder

This is a handy shortcut to adding common filtering to a Query. Click that button, and you will be shown the normal Filter dialog according to the Base Table you're using for the Query. This may be used for queries based on Reservations, Sites, Transactions, Inventory Items, or Purchase Orders.

In the Filter dialog, select the filtering you would like to use, for instance just as if you're using the Find Reservation function. When you click OK, one or more Expressions will be added to the filter conditions which will emulate the filtering you selected.

You can use this multiple times if needed, and it will keep adding the appropriate expressions. While once is usually enough to cover everything, you may need to do this to select more than one type of date range filtering for reservations (for instance to select reservations Made during a certain range that were also Cancelled during a certain range).

You'll also note that when a date filter is selected on one of those filters, a special option will be shown to use the Query 'From and 'To' dates rather than a fixed date range. This is important so the Query's From and To dates are adjustable and will affect the filter appropriately, if you want that ability.

Text Search Conditions

If the Query includes a Text filter, then you need to include a condition for that. The text to be searched (entered by the user with the F9 key or Search button) is available in the context function **ThisSearchText**. Here's an example filter expression to look up transactions that include the entered text in their receipt number:

```
ThisSearchText() != "" AND Find(Tran:Tran_Invoice,ThisSearchText()) != 0
```

Note that the expression above also checks for the search text being blank, so that if no text is entered then it will result in False -- no records will pass the test. That keeps the Query from showing *all* records until search text is entered (which could be rather slow if this is the only condition).

Speed Considerations

Note that any number of filter condition expressions can be used. Technically, you could include all filter conditions in one expression (using "AND" logic), but this can actually result in a slower query because it has to execute every part of the expression. If the filtering is broken up into multiple expressions, then it only executes the expressions until a False condition is found and then it can skip the rest.

If speed is a significant issue, you can rearrange the conditions to put the most likely "False" conditions at the top (so less expressions are executed for most records). Or if some expressions are more complicated than others, you can put the "faster" expressions at the top and leave any really slow ones for last, which would only be executed if the record passes all other "quick" tests.

Also note that all filter expressions are pre-parsed -- that is, the parsing portion of the expression processing is done only once each time the Query is refreshed, so it doesn't have to be done every time the expressions are used to filter a record.

Filter Expression Errors

It's important to know that if a filter expression results in an error, then the record is considered to have passed the test (the same as the condition resulting in True). The reason for this is that it's easier to locate the problem if it shows too many records than if it shows none at all.

Save & Test Query

This function is invoked from the Edit dialogs for either List Queries or Cross-Table Queries. This dialog may also be shown for a particular Query through the **ShowQuery** Expression function. It simply shows the Query in a grid, with From and To date selections like the Queries Tab View would. If the Query has a text filter, you can also enter the text to filter. This allows quickly testing the query to see what it will look like, without completely exiting the Edit function.

Note: Be aware that clicking Save & Test from an Edit Query dialog **does** completely save any changes you've made to the Query, so it negates any possibility of canceling changes you've made.

When you use the Save & Test function from an Edit Query dialog, any errors in the expressions of the query will be shown here as pop-up tips on the cells (when you put the mouse over the cell). Sometimes an error will mean that a cell appears blank when it should otherwise have data, so try holding the mouse over any blank cells to see if there's an error message. Note that errors also appear this way when the Query is shown elsewhere also, but only if you're logged in as an Administrator.

This dialog simulates the Queries Tab View in nearly all respects, including the right-click menu functions and double-click actions.

Editing Cross-Table Queries

The Edit Cross-Table Query Definition dialog is shown when adding or editing cross-table queries from Queries Setup. Other functions where Queries are referenced, such as the Queries Tab view, may also have a button to directly Edit the Query without leaving that function and going through Queries Setup.

Here you can edit all of the components of the Query. The top portion has a few basic fields you can edit directly and buttons for editing the Filter Conditions for the Query and Testing the Query. Next is a grid for editing the "Axis/Grouping" definitions, and the main portion of the dialog for editing the "meat" of the Query -- the Data Expression and various formatting/action information.

Query Name

The name should be descriptive enough for selecting the Query out of a drop-down selection list. Queries will usually be shown in the order they appear in Queries Setup, not alphabetical, so the name doesn't affect the order. Each Query must have a unique name (which is not case-sensitive).

Base Table

The base table determines the primary data table of the Query -- that is, which records are potentially going to be included in the Query. For instance, if the base table is Reservations, then the Query will include all Reservation records by default, subject to the Filtering Conditions.

Any table in the database may be selected, but only a few are useful for most situations -- Reservations, Customers, Transactions, and Sites.

For more details about base table selection, refer to Editing List Queries in a previous section.

Save & Test Query Results

This function invokes the Save & Test dialog, which shows the Query in a grid. This can be used to test the query, without completely exiting the Edit function. Be aware that it **does** completely save any changes you've made to the Query, so it negates any possibility of canceling changes you've made.

Access Level

The access level simply determines which operator access level is required to view the Query. If the current operator does not have the selected access level, then the Query will not be shown in the selection list on the Queries Tab view, for instance.

Exclude from Lists

When this is checked, the Query will not be shown in any selection lists such as in the Queries Tab view. Note that this does not actually disable the Query -- e.g. if it was already selected as an add-on for a tab view then it will still be used in that function. However it won't be available as a general selection, which can be handy for keeping special-purpose Queries out of view. Of course this also means that you would need to uncheck this again (temporarily at least) if you ever did need to select the Query somewhere. Another alternative would be to set the Access Level for such Queries to Administrator, assuming that most operators are non-administrator.

Note that one place this does not affect is the Tab Views Setup (since this is assumed to be an administrator-only function anyway).

Filtering Conditions

The filtering conditions determine which records of the Base Table are included in the Query. Without any filtering conditions, ALL records are included. Refer to the Filter Conditions section above for more details.

Includes Text Filter

When this option is checked, the user will have the option to enter search text. You should include a filter condition that checks this text against the appropriate field, e.g. a customer name, site number, confirmation number, etc. While not necessarily useful for most cross-table queries, you can use it as a free-form filter, e.g. to show the results for only a certain operator, or only a certain reservation type (assuming you have the Filter Conditions set up accordingly).

Axis/Grouping Definitions

The Axis/Grouping definitions determine what kind of cross-correlation the query is going to show. These are shown in a grid, and the Add/Edit/Delete buttons to the left are used to modify them as needed. Note that the order of these in the grid does not matter. Currently there must be exactly two axis definitions, one for rows and one for columns, although the grid is designed to hold more than two (for future expansion, e.g. to allow sub-totaled cross-tables).

The most common combination of groupings uses one axis for dates (e.g. daily or monthly totals) and another for some other grouping of interest (e.g. transaction categories, reservation types, site types, etc.) This equates to the "Group by" and "Summ by" selections in transaction summary reports and most statistical reports available in the Reports menu. However it's also possible to make both groupings non-date, e.g. to cross-correlate reservation type with discount type, or how-heard with rig type (use your imagination!).

For more details, refer to Cross-Table Axis/Groupings.

Calculated Data Expression

This defines the "meat" of the Query. To edit the expression, click the Edit button or simply click on the text box below it. This invokes the Expression Creator dialog to edit the data expression.

After all of the cross-axis grouping is done to figure out what records are to be used to calculate each cell of the Query, the Data Expression is executed for each cell (each row and column combination). Obviously you need a way to get the list of records in the cell, and a way to do calculations from those records. The context functions **ThisListCount** and **ThisListRec** are used to access the records for each cell. Most cross-table Queries will involve summing up something about the records, so here's a simple example to add up the amount of Transactions for each cell (assuming the base table is Transactions):

```
LoopSum(1, ThisListCount(), "#i#", 'TranBalAmount( ThisListRec( #i# ))')
```

The expression above simply sums up the transaction amounts for each record in the list (**ThisListRec**) from 1 to the number of records in the list (**ThisListCount**).

There may be cases where you don't need to do anything with the records in the list, just show how many are in the list (included in the group), like in an Arrivals Statistics report. In that case the data expression can simply be **ThisListCount()**, which returns the number of records in the grouping.

While the expression's results don't need to be numeric, keep in mind that if you plan to show any kind of totals for the rows or columns then it must be numeric.

Data Color Scheme

If you want to use something other than the default Windows colors for the data in the grid, then you need to use a Color Scheme. Appropriate context will be available in the color scheme, such as the list of records being shown for the cell and the from/to dates selected for the Query. Thus you can create a color scheme that colors the data according to content or anything else about the record being shown. There are other context functions available specifically for cross-tables, which usually start with "ThisGroup". For instance, **ThisGroupText** will contain the heading text of the cell's group, and **ThisGroupFromDate** will contain the starting date for the cell.

The most common use for this in Cross-table Queries is to show negative values in red. This can be done easily using the **ThisValue** context function to get the value being shown in the cell. For example, create a Color Scheme with this expression for rule with red text:

```
ThisValue() < 0
```

If you haven't created the color scheme you need yet, or if you find that adjustments to the color scheme are needed, then you can use the Edit button next to the color scheme selection list.

Format

This determines the format of all numeric values in the Query, assuming the Data Expression results in a number. For non-numeric data, the "General" option should be chosen. For numeric data, select an appropriate format, e.g. Currency, Integer, Percent, or Floating Point. If none of these quite fits your needs, then you can select Custom Format and enter an expression to format the data any way you need to.

The Format specification also determines the format of the row and column totals, if they are used in the Query.

Custom Format Expression

This field only appears when the Format selected above is "Custom Format". To edit the format, click the Edit button or simply click on the text box below it. This invokes the Expression Creator dialog to edit the format expression.

For the most part, the format expression should simply convert a numeric value to text. The numeric value to be formatted will be available with the context function **ThisValue**, which will already be shown in the expression the first time you edit it. There are several functions available for formatting numeric values. For a simple example, lets say that we want to take the number and show it as a currency value rounded to the nearest dollar. The expression entered would be:

```
Currency( Round( ThisValue(), 0))
```

Align Text

Select the desired alignment, or justification, of the data in the query grid (including any totals shown).

Pop-up Tip Expression

If you want something to appear in a pop-up hint whenever the mouse cursor is placed over a cell, then you can enter an expression here. To edit the tip expression, click the Edit button (or simply click on the text box below it). This invokes the Expression Creator dialog to edit the tip expression.

The result of the expression should be a text string to be displayed. Typical context will be available for the cell underneath the cursor, so the expression can use the value in the cell, group information, or fields from the list of records being shown.

Note that the pop-up tip can only be a single line, so be careful about its length.

Double-Click Action Expression

This can be used to make something happen when a cell is double-clicked on. To edit the expression, click the Edit button or simply click on the text box below it. This invokes the Expression Creator dialog to edit the expression.

This expression could be anything from showing a message box with information about the cell's contents to executing a Script performing all kinds of functions, even changing the values of fields. Just be careful about doing things that can't be easily undone, since a double-click might be accidental.

Notes

You can enter any notes for yourself here, or use this as a description of the Query -- they're only seen here and in the list in Queries Setup.

Cross-Table Axis/Groupings

The Edit Cross-Table Query Axis/Grouping Definition dialog is only shown when you Add or Edit an axis/grouping from the Edit Cross-Table Query dialog. Here you can define the grouping criteria for a row or column of the Query.

The term "Axis" comes from mathematical X/Y graphing, where one axis is horizontal and one is vertical (in this case, rows and columns of values in a grid). From here on, we'll just refer to them as "Groupings", since in the context of this dialog you're really defining how the records are grouped to form rows or columns.

A Cross-table Query must have a Row grouping and a Column grouping, creating a cross-table grid of values where each cell in the grid results from records that meet both the row and column condition for that cell. For instance, let's say you have a Reservation-based cross table, with the column grouping being months and the row grouping being Reservation Type. So for each month you'll have a column, and for each Reservation type you'll have a row, and each cross-table cell contains the records meeting the month and type conditions for that column and row.

Note that whenever we refer to "base table records" or "all records" here, this is of course subject to the Filter Conditions of the Query itself.

So with that in mind, remember that this dialog only defines **one** of the two groupings at a time, either the rows or the columns. You'll be adding each of the groupings from the Edit Cross-Table Query dialog.

Axis name

This is just a name for your reference, which will be displayed on the Edit Cross-Table Query dialog. Keep it simple but relevant, like "Dates" or "Types".

Axis Type

This is either "Rows" or "Columns", whichever this grouping defines. Later versions may allow other options for sub-groupings.

Grouping Type

There are several types of default groupings available, which mostly just help you define the conditions of the query more easily than raw expressions alone, but also may affect what context information is available for the group's expressions.

Each type of grouping requires different information to define it, as described below.

- None (single result) -- If you only want a single row or column, without any grouping.
- Dates -- Group by date, e.g. daily, monthly, etc.
- Records of a Table -- Create a group for each record in a selected table, e.g. each Site.
- Items of a Pick List -- Create a group for each item in a selected Pick List, e.g. each Site Type. The "Selection Name" text of the pick list will be shown.
- Items of a Fixed List -- Create a group for each item in a selected Fixed List, e.g. each Transaction Type.
- Expression, Filtered or All -- Create groups with headings according to an expression you define (see below for details).
- Custom Groupings only -- Don't create any default groups, but use the ones you defined.

When a grouping type is selected, you'll see two things happen -- Other fields may appear for entering the details, and a default Group Conditional Expression is supplied to help you get started (which in some cases is already exactly what you need).

Date Grouping

If the "Dates" grouping type is selected, you can select a Date Grouping of Daily, Monthly, Quarterly or Yearly. The date grouping of course defines what groups are created (limited to the From and To date range in effect for the Query), and the date range that will be included in each group. When any date grouping is used, the context functions **ThisGroupFromDate** and **ThisGroupToDate** can be used to get the date range included in the group, in any of the group expressions.

You can optionally provide a Group Headings Conditional Expression. This expression will be executed for each date range being considered as a group, so that you can filter which groups in the overall date range will be included in the report (for instance you could use this to only include certain days of the week). The context functions **ThisGroupFromDate** and **ThisGroupToDate** will be available for this conditional expression.

Note that no matter what date grouping type is used, the From and To dates selected for the query will limit the actual groups created (and will most likely limit the records included in the query, since they're most likely being filtered by date in the Query's Filter Conditions.) Thus a Monthly column grouping will show a month for each column, but the data contained in the column may still only include one day.

Table & Heading Field

When "Records of a table" grouping is selected, you need to select the Table to be used and the Heading Field to be used for the group headings (row or column headings). For instance you might select the "Sites" table and the "Site Name" for the heading field so it shows the site names. A group will be created for each record of the selected table, regardless of any filtering -- **every** record of the table considered a group even if none of the Base Table records are related to it (e.g. even if a Site is inactive or has no reservations, it would be included). The default sorting of the records is the actual record order in the table.

The context function **ThisGroupRec** will be available to get the group's record (e.g. the Site for this row) in the group expressions, and **ThisGroupText** can be used to get the text of the record's selected field for (the group heading).

Pick List or Fixed List

When the "Items of a Pick List" or "Items of a Fixed List" grouping type is selected, you need to select the list to be used. A group will be created for each pick list or fixed list item (subject to the optional conditional expression as described below). For fixed lists, the headings will be the common item selection text. For Pick Lists, the Selection name field of the pick list items will be used. The default sorting of the groups is the order of items in the pick list or fixed list. The context function **ThisGroupText** can be used to get the list item's text (the group heading). Note that if you need the report to use the "Report Heading" text of the pick list instead of the "Selection Name" text, then you must use the "Records of a Table" grouping.

Group Headings Conditional Expression (for Date, Record, Pick List and Fixed List groupings)

This optional expression allows you to filter which groups are actually included in the report. For instance in a Records of a Table grouping, a group would normally be included for every record (e.g. every Site). By specifying a conditional expression here, you can limit the report to only show certain records (e.g. filter out by site type, park, etc.).

This expression is executed for each potential grouping, e.g. each record, date group, or list item. As with any Conditional expression, it should have a boolean (True/False) result -- if the result is True, then the group (record or item) will be included. The context available depends on the grouping type -- for Records of a Table use **ThisRecord()**, for Items of a Pick List or Items of a Fixed List use **ThisGroupText()**, and for Date groupings use **ThisGroupFromDate** and **ThisGroupToDate**.

Group Headings Expression (for "Expression" grouping types)

When "Expression, Filtered" or "Expression, All" is selected for the grouping type, you also need to enter a Group Headings Expression. This expression will be executed for each record of the Query's base table (**ThisRecord** will have the record context) and must have a text result type (within this expression. Each unique text result created will be used as a group definition, the result text being used for the actual row or column headings. The context function **ThisGroupText** can be used to get the expression's resulting text (the group heading) in other functions such as the Group Conditional Expression and Group Sorting Hierarchy. By default these headings are sorted in the order that the unique values are found (e.g. no sorting is done).

If "Expression, Filtered" is selected then only records that pass the Query's Filter Conditions will be used to determine the groups (i.e. the Group Headings expression is only executed in the context of those filtered records, and only those results will be used as groups). If "Expression, All" is used, then the filtering is ignored and all records of the base table are used.

A common use of this type of grouping is to group transactions by Operator, since the Operator field of transactions is just a text field. If the "Expressions, Filtered" grouping type is used, then you would expect the report to only include operators involved in at least one transaction in the date range of the report. If the "Expressions, All" grouping type is used, then the report will include all operators who were ever involved in a transaction, even if they didn't have any for the transactions in the Query's date range. Either way, the Group Headings Expression in this example would simply be **Tran:Tran_Oper**, which returns the operator name for the transaction. Of course this assumes that the base table for the Query is "Transactions".

Show totals for each group

If this box is checked, then the "totals" will be calculated for the column or row and shown at the bottom or side. If the Axis Type is "Columns", this determines whether totals are shown at the bottom (totaling each column). Likewise, if the Axis Type is "Rows" then this option will show totals on the right-hand side, totaling each row.

The calculations for the totals shown can be a Sum, Average, or Count. Sum is obviously just the sum total, Average will divide the total by the number of records involved, and Count will simply show the number of records.

Align headings text

This is simply the text justification used for the headings. Usually "Center" is best for columns and "Left" for rows.

Group headings color scheme

If you want to use something other than the default Windows heading colors, then you need to use a Color Scheme. Appropriate context will be available in the color scheme for the grouping (as described above), in addition to **ThisListCount** and **ThisListRec** for access to all records included in each group. Thus you can create a color scheme that colors the data according to group's heading, record or date information, or anything about the records being shown (e.g. the color could be based on how many records are included in the group or even the total transactions amount).

If you haven't created the color scheme you need yet, or if you find that adjustments to the color scheme are needed, then you can use the Edit button next to the color scheme selection list.

Group Conditional Expression

This is the most important aspect of the grouping -- The Group Conditional Expression determines which records (from the Query's Base Table) are to be included in each group. The expression is executed for every record to be included in the Query (subject to the Filter Conditions for the Query), with the context of each group (the row or column grouping information, from context functions as described above). The expression must return a boolean value -- True if the record should be included in the group and False if it should not.

Note that the expression is executed for every grouping expression (for each record) to see if it's included in the group, not just until it finds a True result -- thus it's possible that a record might be included in more than one group, or even all groups. This is normally not desired, but it's certainly possible with the appropriate expressions.

When the Grouping Type is selected, a basic default expression appropriate for that grouping is entered here automatically. In some cases where it can't determine what needs to be used, it will include text like "<fill in field name>". You just need to edit the expression and insert the appropriate field name. Of course these are just basic assumptions, and may not be what you need, but it's intended to provide a hint of what's needed in the expression.

Group Heading Sorting Hierarchy

If the order of the groups is not what you want by default, then you can use one or more expressions to determine the group order in the rows or columns. The context of the group is available for the sorting expressions as described above (e.g. the heading text, record or date information). To edit the sorting hierarchy, click the "Edit group heading sorting hierarchy" button above the list.

Note that this sorting is only done for the "default" groupings as defined by the Grouping Type. It does not affect any Custom group Definitions -- all custom groupings will appear after the sorted default groupings.

Context for Expressions

The context functions available for each grouping type are detailed below. These context functions are available to any expression executed for a particular cell in the cross-table:

- The Group Headings Expression (if using an "Expression" grouping type)
ThisRecord() / ThisResv(), etc for the base table record being grouped
- The Group Headings Conditional Expression (for non-"Expression" grouping types)
ThisRecord(), if "Records of a Table" grouping, for that table's records
ThisGroupText(), if "Pick List" or "Fixed List" groupings, for the list's selection name
ThisGroupDate() / ThisGroupFromDate, if "Dates" grouping used
- The Group Conditional Expression
ThisRecord() / ThisResv(), etc. for the record being tested for inclusion in the group
ThisGroupRec() if it's by table,
ThisGroupText() if it's a records of a table, pick list, fixed list, or expression
ThisGroupFromDate() / ThisGroupToDate() specify the group's range for a date grouping
- The Group Heading Sorting Hierarchy expressions
ThisGroupRec() if it's by table,
ThisGroupText() if it's records of a table, pick list, fixed list, or expression
ThisGroupToDate & ThisGroupFromDate if it's grouped by dates

- The Group headings Color Scheme
 ThisListCount() & ThisListRec(n) of the records
 ThisGroupRec() if it's by table
 ThisGroupText() if it's a table, pick list, fixed list, or expression
 ThisGroupToDate & ThisGroupFromDate if it's grouped by dates
- The Calculated Data expression (in the Edit Cross-Table Query dialog)
 ThisListCount() & ThisListRec(n) of the records
 ThisGroupRec(), ThisGroupText() for the non-date axis
 ThisGroupFromDate() & ThisGroupToDate() for the date axis
 ThisGroupRowRec(), ThisGroupColRec(), ThisGroupRowText() & ThisGroupColText()
- The Data Color Scheme (in the Edit Cross-Table Query dialog)
 ThisListCount() & ThisListRec(n) of the records
 ThisValue() & ThisTextValue() for the body results & totals
 ThisGroupRec(), ThisGroupText() for the non-date axis
 ThisGroupFromDate() & ThisGroupToDate() for the date axis
 ThisGroupRowRec(), ThisGroupColRec(), ThisGroupRowText() & ThisGroupColText()
- The Pop-up Tip expression (in the Edit Cross-Table Query dialog)
 ThisListCount() & ThisListRec(n) of the records
 ThisGroupRec(), ThisGroupText() for the non-date axis
 ThisGroupFromDate() & ThisGroupToDate() for the date axis
 ThisGroupRowRec(), ThisGroupColRec(), ThisGroupRowText() & ThisGroupColText()
- The Double-Click Action expression (in the Edit Cross-Table Query dialog)
 ThisListCount() & ThisListRec(n) of the records
 ThisGroupRec(), ThisGroupText() for the non-date axis
 ThisGroupFromDate() & ThisGroupToDate() for the date axis
 ThisGroupRowRec(), ThisGroupColRec(), ThisGroupRowText() & ThisGroupColText()

Note that the **ThisGroupRec** / **ThisGroupText** / **ThisGroupDate** context functions are only useful outside the group-specific expressions when there is one date group/axis and one non-date group axis (text or record). If you have a cross-table where both groupings are non-date, then use the row and column specific context functions like **ThisGroupRowText**, **ThisGroupColText**, etc..

Cross-Table Custom Groupings

The Edit Custom Grouping Definition dialog is invoked from the Add or Edit Custom Group button in the Edit Cross-Table Axis/Groupings dialog. This dialog has a Group Heading field (the row or column heading text) and a large window to edit the Grouping Expression. It also has buttons to Insert Elements and Test/Edit the expression, which work like the Expression Creator dialog.

You can add any number of custom group definitions to a cross-table grouping definition. Each one is simply a column heading and an expression. A list of any already defined is shown on the Cross-Table Query editing dialog with the typical buttons for adding, editing, moving, copying and deleting them. The order of the definitions in the list determines the order in the Query, and any defined as custom groups will appear "after" any default groups as defined by the Grouping Type -- e.g. they will be the bottom-most rows or the right-most columns (not including Totals). Of course if "Custom Groups only" is selected as the grouping type, then only these custom groups will be shown in the Query.

A typical use of custom groups is to include a "(none)" group when the normal grouping is by Sites, How Heard, Discount, etc. where there might be records with no value for this information. For instance to include a no-site grouping, add a custom grouping with the expression **Site() = NullRecord()**. They also allow adding special columns to transaction reports like Previous and All-Time, or create any type of special groupings you can come up with, providing complete flexibility in the creation of summary reports.

The custom group expressions should have a boolean result, just like the Group Conditional Expressions -- that is, the expression should return True if the record should be included in the custom group, and False if not. Each custom group expression is executed for each record in the Query's base table, just like the Group Conditional Expressions. However the only context information available besides the general query information is the base table record (**ThisRecord**) and the custom group's heading text.

Forms

Overview

The Forms functionality in Campground Master encompasses nearly all types of printable formats that aren't grid types of reports. All customer receipts, envelopes, mailing labels, window tags, purchase orders and even E-mail message formats are part of the Forms definitions. Note that we define Forms only as printable output formats, not as user input formats the way "Forms" are defined in Microsoft Excel or Visual Basic. We refer to input forms as Dialogs, which are set up in a separate section.

Previous versions of Campground Master had a set of receipts, etc. available as "canned" or pre-programmed formats with a few formatting or content options. These are all still available as a pre-configured set of default Forms, so that upgrading will be seamless and new installations have a base set of common forms to start with. These use the same internal code to ensure that no change will be noticed in most cases (there are a few enhancements, such as multi-page receipt support, which affect the "old" receipt formats). All of the previous settings from Printing Options, Notice text, etc. are still used and they still affect these default formats (and in some cases will affect customized versions of these as well).

The Forms Setup functionality adds several levels of customizability not previously available (each "level" of customization below requires more technical knowledge):

1. Any of the default receipts can be disabled, renamed, or rearranged in the selection lists to suit your preferences.
2. Form elements such as text, data or graphics can be added on top of existing "canned" receipt formats.
3. A format can be modified more extensively by importing custom Form templates, which replicate the canned Forms in most respects, and making changes to them.
4. Completely custom Forms can be created from templates or from scratch.

Any modifications other than the first level above will require at least some knowledge of Expressions, and a fair amount of programming expertise is recommended for the 3rd and 4th levels.

Multi-page forms

In addition, a special "Section" feature allows creation of multiple-page Forms with different information on each page. (We don't call it "pages" because a normal form with a single "section" can go to multiple pages automatically based on the number of transactions.) For instance you could create a single 4-section "receipt" format which includes 2 copies of the Ticket Form (one requiring a signature for your records), a Window Tag, and a letter explaining all of your policies (however all sections in a single Form must go to the same printer). So it would print 4 separate pages (or more, if necessary for the number of transaction lines needed). See *Editing Forms* for more details.

Forms Setup

To create a Form, go to Maintenance / Advanced Customizations / Forms. This opens the Forms Setup dialog, which lists all current Forms and has the typical functions for Adding, Inserting, Editing, etc. Note that while there are functions to Move Up and Move Down, a Form's position in the list does not affect any functionality other than its order in drop-down Form selection lists that the user sees. This of course may be important to you for organizational purposes.

You can also [Export](#) one or more Forms to a text file, or [Import](#) Forms. This is primarily for you to import Forms created by the software provider, though it can also be used to transfer Forms between multiple databases.

Forms cannot have duplicate names (or else they could not be uniquely selected from a list). If you make a [Copy](#) of a Form, text like "(copy 1)" will be added to the name to make sure it's unique. Of course you can change this to be more appropriate. Duplicate checking for the names is not case-sensitive ("My Form" is considered the same as "my form").

Add the default forms

This special function will add all of the default receipts to the list (plus other Forms like envelopes and labels). The main purpose of this is in case you make some changes and then want to get back the original settings. Note that it will only add defaults that do not already exist, according to the Form names, since duplicate names are not allowed. Thus if you make changes to a default that you want to undo, you need to delete the original first before adding the defaults. A "fresh" copy of any deleted will then be added to the end.

Renaming Forms

If you want to change the name of a Form (for the selection lists), then select the Form in the list and click [Edit Form definition](#). The Edit Form dialog will show the current Form name at the top. Just change the name as needed and [Save](#) it.

Rearranging Forms

The order in which the Forms appear in selection lists, for instance in the Transactions dialog, is determined by the order that they appear here in Forms Setup. If you want to move them around, for instance to make the most-used Forms appear at the top (or nearer to the default Form selected in Printing Options), then use the [Move Up](#) and [Move Down](#) buttons to move one or more selected Forms.

Disabling Forms or changing access levels

If you don't want so many Forms in the receipt selection lists, you can disable the ones you don't use. Technically you could also [Delete](#) them, but it's better to just disable them in case you want to use them later. To disable a Form, select it in the list and click [Edit Form definition](#). Then in the Edit Form dialog, uncheck the "Enabled" box and then click [Save](#).

Changing the access level for a Form is basically done the same way -- go into [Edit Form Definition](#), and select the desired [Access Level](#).

Changing the number of transactions printed on a page

The space available for transactions on the receipts can vary depending on the number of "Additional sites" (linked reservations) or Receipt #'s (separate transaction sessions), as well as other factors like including credit card information. Each Form is set up with a specific maximum number of transactions that it can print per page (it's not "intelligent" enough to figure that out automatically for each receipt), but this may be too many in some cases, or perhaps you find that it can fit more. To adjust this, select the Form in the list and click [Edit Form definition](#). Then in the Edit Form dialog, change the "Trans rows/page" value and then click [Save](#).

Adding elements to the default formats

Each of the default format entries is set up as an "Add-on" Form, essentially as a blank custom Form on top of the corresponding canned default Form. This means that it still uses internal code to create the receipt Form, instead of using custom Form elements, so that all Forms still work the way they did in previous versions. These "canned" Forms are also a little more flexible than a custom Form could be, and also faster.

However since they are still Form definitions, you can add Form Elements to them. Anything you add will be printed "on top" of the Form selected in the "Add-on" field. Thus you can add a logo image, some extra text, or data fields to otherwise blank areas of a Form. (Technically you could overwrite existing Form information, but this is very tricky.) To do this, just select the Form and Edit it, and add Form Elements as required. Just keep in mind that the position of fields on most canned Forms isn't fixed -- much of the information will move around depending on what information is actually needed for the given reservation or customer.

Making other changes to the default formats -- Importing and changing templates

As mentioned above, the default formats are just set up as "Add-ons" to the canned Forms, which don't allow changes to the canned part of the Form other than additional elements. If you need to make changes to the Form, such as moving, renaming or deleting elements, or adding things to it that won't have a fixed position, then you need to be able to edit the actual Form elements. This isn't possible with the canned Forms, so we've created sample templates that duplicate the canned formats as close as possible. See the following section *Importing and Editing Sample Forms* for details.

Creating custom Forms from scratch

If none of the standard forms or sample forms work for you, then of course you can create a Form from scratch. Just click [Add Form](#) or [Insert Form](#), enter the name and basic information and start adding Form elements. See the following Editing Forms section for details.

Importing and Editing Sample Forms

Sample templates that duplicate the canned formats as close as possible have been created, so you can edit the form as a fully customized form with all of the individual elements. There are a few aspects that aren't quite possible to duplicate (or were too difficult to be worthwhile), but for most users this won't be a problem.

To use these templates, you must first Import them. Click the [Import Form\(s\)](#) button, and you'll get a typical Windows file dialog labeled "Import Forms". You need to locate the sample Forms folder, which is typically **C:\Program Files (x86)\Campground Master\Samples** (most likely you just need to double-click the "Samples" folder to get there). Now select the appropriate file, for instance "Sample Form - Custom versions of Ticket Forms" to get the Ticket Form template, and [Open](#).

Note that the import/export files use the "CSV" file extension (e.g. Sample.csv), which means it's a comma-separated-value text file. Windows may recognize this file extension as something another program can open like Excel, but these are in a special format for importing records to Campground Master and should not be used in other functions. Also avoid opening different kinds of samples which use the same extension (e.g. don't open a Form sample from an Import Script function).

When you're importing sample Forms, it may also import Macros or Scripts that are used in the Forms. If these are already defined, resulting in a duplicate name, then a warning will be shown listing the duplicates and what their names were changed to during the import. These might be safe to delete, assuming the imported version does the same thing as the original version. Otherwise you will need to change any expressions in the Forms that use the Macro or Script so that it uses the correct name.

Once the sample is imported, you'll see it appear in the Forms list (probably with a name starting with "Custom". You'll probably want to move it to the top of the list for easier location. Now you just need to Edit the Form to make any changes you need. You'll notice that the sample Forms make heavy use of Regions to

sub-divide the Form's data areas. This is recommended so that you can do things like export/import regions, move entire areas easily, and "name" regions for easy reference when editing.

Note that these sample templates do contain the entire Form defined as Form Elements, so any aspect of the Form can be changed. Even if you want to create your own Form that's nothing like one of the others, for instance a letter that's nothing like the normal confirmation letter, you might as well import the confirmation letter template and delete everything except the header regions (the park & customer address information) so you have a good starting point.

You may also notice that the sample Forms use the settings from Printing Options and Park Setup wherever it's applicable, e.g. to show the site name, abbreviation or type, and to get the text to be shown at the bottom of receipts. This is done by using functions like **SettingText()** or **SettingLocalBool()** in the Data or Condition expressions of the Form elements. If you're making your own custom versions, you may want to replace these with your own text or conditions as appropriate, or you may prefer to leave them so that changes to Printing Options still affect your custom Form.

E-mail Forms and HTML E-mail

One of the common issues is creating or enhancing new E-mail forms, e.g. for confirmation letter variations, other types of E-mail like cancellation letters, thank-you letters, etc. There are several sample forms available for import that will help you get started with making your own set of E-mail forms, including several varieties of confirmation letter formats, a cancellation letter, and a thank-you letter. For details on what is required for using HTML E-mails, see the section under Maintenance Functions, E-Mail Setup, E-mail Form Customization and HTML Forms.

Editing Forms

The [Edit Form Definition](#) dialog is shown when adding or editing Forms from Forms Setup. Other functions where Forms are referenced, such as the Form Selection dialog, may also have a button to directly edit the Form without leaving that function and going through Forms Setup.

Here you can edit all of the components of a Form. There are a few fields you edit directly here, and the main portion of the dialog for editing the "meat" of the Form -- the Form Elements.

Form Name

The name should be descriptive enough for selecting the Form out of a drop-down selection list. Forms will usually be shown in the order they appear in Forms Setup, not alphabetically, so the name doesn't affect the order. Each Form must have a unique name (which is not case-sensitive).

Enabled

The Form can be disabled so that it does not appear in receipt selection lists (just uncheck this option). Technically you could also delete the Form, but it's better to just disable it in case you want to use it later. This is also handy to disable Forms you haven't finished, so the users don't try to use it (giving it a high Access Level may also be helpful for this).

Form Type

There are several Form types to choose from, which primarily determine where the Form will be shown as a selection. For instance a Reservation Receipt format won't be shown if printing a receipt for Unbound Transactions, and Label Forms will only be shown where it's possible to print a labels (where multiple records are involved, e.g. the Reports / Mailing Labels function or Find Customers).

Besides being useful for keeping Forms organized according to their use, some types affect what the Form can contain or what other settings it will have. For instance, only the Receipts Form types can have transactions in them (at least for the normal purposes of showing them in a Transaction Table element). Other special situations are mentioned below.

Labels print multiple "Forms" per page (e.g. one instance for each record in a list), and thus have settings for position, spacing, and the number of rows and columns per page. Of course this technically doesn't have to be just mailing labels -- you could use this for any special Forms where several records need to be printed per page, such as a reservation summary report with many details per reservation that wouldn't fit in a single-row-based Query.

E-mail Form types must have "Text output" for the Printer selection (they can't actually be printed), and "Character positions" for the Format (their elements can't be positioned in absolute coordinates on a page).

The Window Tag type has a special situation -- if the "Print Window Tag" button is used on the Reservation Transactions dialog, it will auto-print the top-most Form with this type. This is a special case where the order of Forms is also important. Note also that Window Tag Forms should always be Reservation-based.

Add-on

If this is checked, you can select one of the "canned" formats as a base for the Form. Nothing about this canned Form can be modified, but you can add elements on top of it. This is a means to make simple add-on changes to one of the canned Forms, and of course it's also how all of the default Forms are set up (ass add-ons with no added elements). Be careful to select an appropriate Form Type for the add-on selected, or else the results may be unpredictable.

If the format of the Form is Character-positions, such as a 3" receipt or E-mail, be aware any elements are added on at the end of the canned Form, not in a specific positions.

Format

The format of a Form determines how things are positioned on it. There are basically two choices -- "Variable positions" (in inches or millimeter units), and "Character positions". Note that the inches / millimeter choices for variable can be changed any time, it won't affect the Form (all Forms are actually stored with inches, and conversions are done only for your convenience in the editing dialogs).

Any Form that's used with a Windows printer driver, e.g. for an ink jet or laser printer, can use the Variable positions format. This allows you to place Form Elements anywhere on a page based using absolute positions, and also allows you to use "Region" elements to sub-divide the Form definition.

The Character position format is primarily for use in E-mail Forms and 3" receipt printer Forms where the direct-to-port functionality is used. Forms with this format must position the Form Elements using character positions (line and character column), and can't use Regions. Generally you want to define the lines of these Forms in order, top to bottom (the same order it's going to be printed), but this isn't strictly required since the Form's output character array is "built" internally before sending it to the printer. Note that a Character format Form must select a printer type of either Text Output or 3 Printer - Direct to Port.

Fixed-Pitch Text

This option only appears/applies if the Form Type is E-mail. When selected, the E-mail will actually be sent as HTML with the "pre-formatted" tag (<pre>), so that it displays as fixed-pitch text (the user will not see this when sending the E-mail, it's done behind the scenes). This is especially important if the E-mail has a transaction table in it, so that the column with the amount lines up neatly. When previewing the E-mail you will also see it as fixed-pitch text.

Character columns

This is only shown for Character format Forms. An appropriate number of columns should be entered so that the "bounds" of the printer is known. This is important for aligning text (e.g. right-justified or centered), and also for auto-wrapping long text.

For 3" receipts, 40 columns is recommended (though some might only work with 39 columns).

For E-mail, we suggest using 70 to 80 columns, though it may work also to put 0 or 9999 columns so that text is not wrapped around automatically (assuming the receiver's E-mail program will wrap appropriately) -- and this also assumes that you never use right-justified or centered text, or a Transaction Table.

Trans rows/page

This is only an option for Add-on Forms where a canned receipt is selected. Since these have transaction tables in them (but not as editable elements), you must choose how many rows of transactions can be printed on each page. If the number is too high, transactions may be cut off or overlap text at the bottom of the page.

Since some receipts may have a lot of "extra" stuff pushing down the transactions or appearing below it (like credit card info, "Additional sites", or multiple Receipt #'s), it's best to enter a lower number and let it print multiple pages even when there's some extra room.

Printer

This simply determines which printer from the Printer Setup selection is used for printing the Form. If you print everything on a single printer then this may not matter, but it does allow selecting different printers or have different settings for each type of Form. For instance you might prefer to print some Forms in landscape mode and others in portrait mode, so you need to use different Printer selections. Also, Envelopes and of course 3" receipt formats should use the appropriate type.

There are also 4 custom printer selections in case you have special Forms that need specific printer settings.

One of the Printer settings is "Text output (or E-mail)". This must be selected for any E-mail Forms, or any Character-format Forms that don't go to the 3" receipt printer. It can't be used for Variable-format Forms.

Sections (unique pages in a multi-page Form)

The Sections functionality allows for Forms to have multiple pages with different information on each page. Or instance you can create a custom Form with several parts on different pages, and they will all print at once when the Form is printed. Of course most Forms will just have one section.

Note that this does not affect multiple-page printing due to transactions table overflow -- e.g. if it has 2 sections but one section requires 3 pages due to the number of transactions, then it will print that section 3 times (with appropriate transactions) plus the second section, for a total of 4 pages. Of course it also does not affect printing multiple records -- printing a 2-section Form for 3 records will result in 6 pages.

To use the Sections functionality, you need to include the context function **ThisFormSection()** in the Condition Expressions of your Form elements. Ideally, the main Form will simply have one Region for each section (for logically sub-dividing the Form and making the definition of each section easier), and the Condition Expression for each of those will just check for the section. This each Region is only printed for the appropriate section (page) of the Form -- in other words, the Section is the page number of the Form, not counting the effects of transactions tables overflowing.

For instance: **ThisFormSection() = 1** for the first section, and **ThisFormSection() = 2** for the second section. If you include this in the region's condition, then there is no need to include it in every element contained in each region.

If the Form is an Add-on Form, the receipt type selected will only be in section 1. So you can add an additional custom section to a canned receipt format, but you cannot create a multi-section Form containing more than one canned format.

Access Level

This is used to restrict Forms to certain operator access levels, for instance if you don't want store clerks to be able to print Window Tags. Just select the minimum access level you want to be able to print the Form.

Base Table

The base table determines the primary data table of the Form -- that is, what type of record this Form is going to show information about. This is mostly used for two things -- where the Form is displayed as an option, and what context functions are available for expressions. Any table in the database may be selected, but only a couple are used for most situations -- Reservations and Customers. If you use the Point of Sale, you might also have Forms for Vendors and Inventory Items.

When printing reservation receipts, for instance, only Forms with "Reservations" as the base table can be displayed (selections are also limited by the Form Type as described above). When using Print from Customer Details, the Form Selection dialog will only show "Customers" based Forms, and so forth.

Regarding the context functions, these follow the general rules for expressions. For instance if "Customers" is the base table, then only **ThisCust** is useful. If "Reservations" is the base table, then you can use **ThisResv**, **ThisCust**, **ThisSite**, and **ThisPark**, because the Form is assumed to be in the context of a reservation and all of that information is known for a reservation. For some tables, such as Inventory Items, only **ThisRecord** is useful (the generic record context function).

E-mail Subject Expression

If the Form Type is "E-mail", then this option will be available where you can enter an expression to be used in the Subject line of the E-mail. If this is blank, then the subject specified in the SMTP setup will be used. Otherwise the expression is executed for the applicable context and the result (assumed to be text) will be used for the subject. If you simply want to specify text, then enter the quoted text as the expression, like this: **"Thank you for visiting"**. However you can also include reservation-specific information using the expression, like: **"Thank you for visiting, " + Cust:Cust_First_Names**.

Attach File(s)

If the Form Type is "E-mail", then this option will be available where you can select one or more files that will always be attached to the E-mail.

Caution! The file selection is stored with the specific path on your computer. If you're using more than one computer, or move the database to another computer later, then you need to make sure that the file path will still be correct and that the files exist on the other computer(s). The files are not part of your database so they will not transfer automatically.

Save & Test Form

This function does a test Print of the Form, showing a Print Preview window first. This can be used to test the Form repeatedly without completely exiting the Edit function.

You should be able to do most testing just in the preview without actually printing (Close the preview to avoid printing the Form), though some details will require printing to see the actual result. For instance if text seems to be too long or gets cut off, or lines in a table seem to be obscured by text, this could just be an inaccuracy in the preview.

Be aware that it **does** completely save any changes you've made to the Form as soon as you click the button, so it negates any possibility of canceling changes you've made.

Records (for testing)

There's a Records setting next to the Save & Test Form button, which determines how many records (of the given Base Table) are used for testing. Thus if it's set for 10 records, it will attempt to print the Form for 10 reservations, or Customers, or whatever the base table type is. The default is always 10 records, so if you need more or less, be sure to change it before testing. This number will be remembered for each Form.

This is especially useful for Label Forms, but also handy for other Forms. For full-page Forms, this means that multiple pages will be printed -- in the Preview window, use the "Next page" button to step through them. This is a handy way to check Forms for several situations at once, e.g. different types of reservations with different numbers of transactions. But be careful if you actually Print -- it may print more pages than you realize!

Note that it always uses the most recent records for testing, starting from the last record. For instance it will test using the last 10 reservations entered (assuming 10 is entered for records, and "Reservations" base table). This allows you to add some test reservations before testing and it will use those. If you need to test with a specific record, you can go to the editing function for that record (e.g. Customer Details), and print from there using the normal functionality (be sure to enable "Always preview before printing" in Printing Options / Receipts so that you get a preview).

As E-mail (for testing)

For any Forms with "E-mail" as the Form type, this option will appear next to the Save & Test Form button. When this is checked, the Form will be tested in an E-mail window instead of a Print Preview window. This shows it in the proper context, but this also limits testing to a single record. Note that it will be tested with the most recent Reservation for which the customer has an E-mail address (or if the Base table is Customers for this form, then the most recent Customer record with an E-mail address is used.).

Note that E-mail Forms tested in the Print Preview window will be limited to one page -- anything more than that is cut off. This is because an E-mail Form (or any Character-format Form) is assumed to be unlimited length so it cannot split it up into multiple pages.

Notes

You can enter any notes for yourself here, or use this as a description of the Form -- they're only seen here and in the list in Forms Setup.

Form Elements List

A list of Form Elements appears on the Edit Form Definition dialog, as well as on the Edit Form Element dialog if the element is a Region. It operates the same way in either place, since a Region element is essentially a Form-within-a-Form.

Form elements are actually "Element" records linked to the Form (or region element), so this list shows those linked element records. As with most places where record lists are manipulated, the typical functions are available to Add, Insert, Edit, Copy, Delete, and Move elements in the list. In addition, there are a few special functions as described below.

The element list contains the Condition and Text of the elements, but depending on the element there's no guarantee that either one of these will be filled in. So putting in good Notes for the elements can help later. Also note that the Text column may show different things, e.g. the Expression for data elements or the file name for Bitmap elements.

Note that the Condition and the Text columns may be truncated (with "..." at the end). This is done automatically to limit the column widths and keep long text from making the other columns hard to find. (Even if the columns or the whole dialog is enlarged, it won't show these fields any longer here.)

Form Element Order

When a Form is processed, the elements are processed one after another in the order they appear in this list. Any Region elements are "recursively" processed -- that is, all of a region's sub-elements are processed before moving on to the next element at the same level (more is explained about "levels" below). While this in itself doesn't always make a difference, the order of elements in a Form is actually very important for at least two reasons.

First of all, it's possible for elements to overlap. Think of an element as "painting" on the page. If one element overlaps another, it's painted on top of it and can potentially cover up the previous element. (Regions can partially prevent this for text and data elements, since they clip the text and act like a "cage" for anything written in the region.)

Secondly and possibly more importantly, it's very common to use relative positioning of elements instead of absolute page positioning. For instance, one element can "follow" another so it's placed on the page relative to where the previous element started or stopped. This way you don't always have to figure out exact page positions -- just arrange the elements in the order you want them to appear on the page. Obviously if the order of these is changed, then it will affect their eventual position on the page (or worse, result in an error due to an unknown "previous" position).

Expand Regions

As mentioned above, Region elements are like a Form within a Form. As such, a region has a list of elements of its own that are relative to that region. This can include another region, and so forth, resulting in multiple "levels" of regions, each with their own list of elements.

By default, the Edit Form dialog or Edit Element dialog for a region will only show the elements linked directly to it -- i.e. the current "level" of elements. As you may see in some of the examples, it's common to define an entire Form inside a region (so the margins can be changes easily), and then have various areas of the Form defined as regions inside that.

This is good organizational practice, but makes it a little more difficult to "explore" the regions to find a particular data or text element -- the top level (the Edit Form dialog) may have just one Region element, then you would need to Edit that region element to see the elements inside it. which may just be a few more sub-regions, and so forth. It may take 3 or 4 levels of "Editing" to get to the actual data and text elements of the Form.

However if you check the Expand Regions box, all regions at or below the current level are expanded into a tree-like list. This allows you to see all elements in the entire Form (or current region) in a single list. To make it easier to read, each level will have a "--->" prefix and will be indented according to the depth, like a tree view. Also, each level will be shaded differently.

You'll notice that some list functions are not available in expanded mode. You can't Insert or Move elements, because it can't handle the multiple-level complexities of this. However you can Copy elements from any level (the new copies will always be placed in the current level). You can also Edit an element from any level, which is the primary reason for expanding the list -- you can quickly locate the element of interest and edit it directly without going through each region above that. (Don't forget that double-clicking an element in the list also does the same thing as Edit).

Import and Export Elements

These functions will import or export any selected elements to a CSV (text) file. The main purpose of this is to copy the elements to a different Form or to a different level (region) of the Form. You can also export commonly used sets of elements for importing to Forms you create later. Basically it's like doing a copy/paste of elements, but going through a file instead of just the clipboard. Note that it's not the same as the import/export function for a complete Form -- it's strictly for copying or moving selected elements. However if an element is a Region, then all of the elements contained in that region are also exported (recursively to any level), and of course they would be imported intact the same way.

When exporting, any elements visible in the list can be exported (even if Expanded as described above), but they must all be of the same expansion level. You cannot select some elements in one level and some elements in another level to be exported at the same time.

When importing, all elements imported are placed in the current level (regardless of expansion). For instance if you're editing a region, then all imported elements are added to that region. If you're editing the Form (the top level), they are added to the Form. Careful manipulation of importing and exporting elements allows you to move elements around between levels, for instance to move some elements to a higher or lower region level.

Editing Form Elements

The Edit Form Element dialog is shown when adding or editing elements from the Edit Form Definition function. It's also used for adding or editing sub-elements for a Region element's Edit Form Element dialog, so you could potentially be multiple levels deep into the same dialog.

Here you edit all of the components of a Form Element. This one dialog is used for all types of elements, even though different information is needed for each type. To help avoid confusion, it will only show the fields that apply to the element type that's currently chosen. Choosing a different Element Type will completely change most of the fields available on the dialog.

The common fields available to all elements are described first, followed by the type-specific fields for each element.

Element Type

Select the type of element you want to show. There are four basic element groups:

Region -- Essentially a Form within a Form, a region contains other elements that are positioned within the region, relative to the region's position. Thus an entire area of a Form can be moved by simply moving the region. Any text elements within the region are also "clipped", so they can't go outside the region. We recommend using regions for any logically similar "part" of a Form to make rearrangement easy. Regions can also be used for the purpose of minimizing condition checks (the region's condition expression only has to be checked once for the whole region, rather than each element), or to help position things in columns (use a region for each column, and text within the region can be auto-wrapped and still stay within the column).

Text / Data -- Anything shown as text characters, either static text or text generated from a Data Expression.

Bitmap / Line / Box graphic elements -- Use a bitmap to include pictures or non-text elements of any kind on the Form. Lines and boxes can also be drawn as needed.

Transaction table -- These are line regions but with specific content, which is basically a canned transaction table. The table can be in several formats. While the flexibility of the data shown in this element is somewhat limited, it's the only easy way of showing transactions on a receipt Form.

Note that Forms with a Format of "Character positions" cannot have regions or graphic elements, and are more limited in the transaction table formats available.

Top / Left

These specify the position of the element on the page (or within the region). Each of these can be specified in one of 5 different ways, which you select from a list. Most will also need a numeric parameter for the position/offset in inches, millimeters or characters depending on the Form's Format, or a percentage value. If it's a character-position Form, character positions start at 1 (e.g. line 1, column 1). For variable-position Forms, positions start at 0 inches or millimeters.

Absolute (in region) -- The numeric value indicates an absolute position on the page (or relative to the parent region's position).

Relative to Prev. element -- The value indicates an offset from the position (top / left) of the element before it.

Percentage (of region) -- The numeric value indicates a percentage (e.g. 0 to 100) of the page or parent region's width / height.

Next avail. (+ offset) -- The numeric value indicates an offset from the "ending" position of the previous element. See notes below.

Offset from right/bottom -- The numeric value indicates an offset from the bottom or right limits of the page or parent region.

These allow a lot of flexibility in positioning elements, often without having to know the exact size of a page.

Note that the offset values for "Relative" and "Next avail." positions can also be negative if desired (e.g. to partially overlap or show a superscript, for instance).

"Next avail." positioning

The "Next avail" positioning option is a very important one for text (but also useful for other elements).

For Text and Data elements, the next available position is pretty straightforward (unless the Angle is non-zero as described below). It's the next character or line position, whether the Form is character based or not. For instance when used for a Top position in an element after a text element, it means the next normal line available or single-spaced text. You don't have to worry about the size of the text or anything about where the previous text ended. If you want a little gap, just include an offset of .05 for instance. Or use -.05 to scrunch the text a little closer together. Likewise, using it for the Left position will start at the next available character position. Of course you wouldn't normally use it for both the Top and the Left, just one or the other depending on whether you want the next text to be on the next line below or on the same line right after the previous text.

For other elements, there are some special considerations:

Transaction Tables -- The next available Left position is the right side of the table's area (not necessarily the last character printed), but the next available Top position is the actual next text line position. This is because it's common to want the next text to start just below where the transactions ended, but there's no way to know how many lines will be in the table beforehand.

Lines and Boxes -- The next available top/left position will be the exact bottom/right of the line or box (mostly useful for positioning the next line or box to be drawn).

Bitmap images -- The next available top/left position will be the exact bottom/right of the image according to the element definition. However this is not necessarily the bottom/right of the image as drawn because of the special cases for zero height or width (see below). In other words if you specify a 0 width, then the next left position will also assume that the bitmap was 0 width even though that really meant to keep the correct aspect ratio. Also note that this may change in the future, so it's best not to use next available positioning after a bitmap at all unless you're specifying the exact size.

Regions -- At the "receiving" end, regions are considered a Form-within-a-Form so the "Next available" position coming into a region, that is for the first element inside the region, will always be zero (which of course is the starting position of the region, not the actual corner of the page). However coming out of a region it remembers the "Next available" position of the last element inside the region. Therefore the next element after the region will know where the actual printing inside the region left off. Thus it's perfectly fine to make a region larger than you expect it might need, and then after the region you can pick up where the last text inside the region actually stopped.

Finally, don't forget the effects of the Condition -- as mentioned below, the "Next avail." position only counts the last element that's actually printed.

Condition

This Expression determines whether the element is included in the Form, and must return a True or False boolean value. If used for a region, it affects all sub-elements in the region also (the entire region is skipped if the condition is False). To edit the condition expression, click on the text box or click the Edit button next to it. The Expression Creator dialog will be used to enter the expression.

Note that if the element is excluded due to the condition, then it's considered non-existent for purposes of positioning also. That is, the "Relative" and "Next Avail." positioning mentioned above refers to the last element that's actually used, not necessarily the one just above it in the list.

Notes

These notes are for your reference, and will also appear in the list of elements. We recommend putting notes in especially for Region elements so you can see what's included in the region, but it's a good idea for any element that's not obvious so you can tell what's going on if you need to edit the Form later.

Region Element Fields

Fields specific to Region elements:

Border

When this is checked, a simple black line will be drawn around the region. Even if you don't plan on having borders in the final Form, this is very helpful in determining whether your region is positioned and sized properly while you're testing it.

Bottom / Right

Regions must have a bottom and right boundary. As with the Top / Left position there are several ways to specify the bottom / right boundaries, with a few minor differences as described here:

Relative (height / width) -- The value indicates an offset from the Top / Left position of **this** element (so it's effectively a height or width value).

Absolute (in region) -- The numeric value indicates an absolute position on the page (or relative to the parent region's position).

Percentage (of region) -- The numeric value indicates a percentage (e.g. 0 to 100) of the page or parent region's width / height.

Percentage, relative -- The numeric value indicates a percentage of the space remaining on the page or parent region, starting from the top / left of the region.

Offset from right/bottom -- The numeric value indicates an offset from the bottom or right limits of the page or parent region.

Sub-elements in Region

All elements contained within the region are shown here, with typical editing functions. This works the same way as the top-level Form Elements List, so refer to that section for details.

Text and Data Expression Element Fields

These fields are specific to text and data elements (with only a couple differences as mentioned below).

If the Form uses Character-position format, most of the font and formatting options are not available -- only the alignment and auto-wrap options can be used. Also note that for Forms using direct-to-port printing, the Text (or Expression result) may have "escaped" hexadecimal characters such as for auto-cutter or cash drawer control. These must be in the form `\xHH`, for instance `\x07` to send the BEL character. Note the direction of the slash (backslash), and that the "x" is lower-case. Also note that if any such escape sequences appear in center-aligned text, the alignment is based on the resulting single character, not the 4-character escape sequence.

Text (only in Text elements)

This is the static text to be displayed. It can actually be any length -- click the Edit Text button to open a larger window to edit long text. Note that the text can also include multiple lines, as long as the Auto-wrap option is also checked (of course this also results in auto-wrapping any lines too long for the region or page). Multiple lines will be shown as-is in the large editing window, but the line breaks will be shown as " \ " in the single-line edit box.

Expression (only in Data Expression elements)

This is an expression which will be executed and the results will be shown as text, subject to the Format below. Once the expression is evaluated and formatted, all other aspects of the element work the same as a text element (e.g. the return value of the expression becomes the "static text" to be shown). To edit the Expression, click on the expression text box or click the Edit Expression button. The Expression Creator dialog will be used to edit the expression.

Format (only in Data Expression elements)

This determines the text formatting of numeric values, assuming the expression results in a number. For non-numeric data, the "General" option should be chosen. For numeric data, select an appropriate format, e.g. Currency, Integer, Percent, or Floating Point. If none of these quite fits your needs, then you can select Custom Format and enter an expression to format the data any way you need to.

Custom Format Expression (only in Data Expression elements)

This field only appears when the Format selected above is "Custom Format". To edit the format, click the Edit Custom Format.. button or simply click on the text box below it. This invokes the Expression Creator dialog to edit the format expression.

The format expression should simply convert a numeric value to text. The numeric value to be formatted will be available with the context function **ThisValue**, which will already be shown in the expression the first time you edit it. There are several functions available for formatting numeric values. For a simple example, lets say that we want to take the number and show it as a currency value rounded to the nearest dollar. The expression entered would be:

```
Currency( Round( ThisValue(), 0))
```

Color

This determines the color of the text and the background of the text. An example is shown with the current colors selected. Click the Text or Background button to change the combination as needed, and these will allow you to choose any color. Of course black text and white background is the default, and the background is typically white (unless you want to use a lot of ink!).

Font

Any font that's installed in Windows can be used, in any size supported, with any combination of Bold, Italic, or Underlined attributes. The most common font names are "Arial" and "Times new Roman", and occasionally "Courier New" for fixed-pitch text. To change the font using the standard Windows font-selection dialog (which usually shows an example of the font), click the **Select Font** button.

Note that new elements will default to the most recent font selected, or the last font used in a Form element, so you don't have to constantly change the font for every element in the Form.

Shrink to fit available width

When this is selected, it can automatically re-size the text to keep it on a single line, within the borders of the page or parent region. You also specify the smallest font size to which you'll allow it to shrink (anything smaller than 8 can be very hard to read). If even the smallest size doesn't allow it to fit, then the text will be truncated (this can't be used with the auto-wrap option).

Align Text

Choose how to align the text on the page (or within the parent region), either Left, Right, or Center. You can also choose to center the text vertically within the region.

Auto-wrap

When this is selected, text that's too long for one line will auto-wrap (without breaking words) to multiple lines as needed. This is also required for supporting text with forced line breaks in it -- essentially any text that you don't want limited to a single line.

Angle

Using this is rather tricky, but it does allow support for drawing text at any angle. Enter a number from 0 to 360 (0 is normal horizontal, 90 is "up", 180 is upside down, etc.). Note that the text may or may not obey the bounds of any region, and the Auto-wrap, Alignment, and Shrink-to-fit options will be ignored. Only single lines are supported. Also, the "Next Avail" positioning of the next element may or may not have the results expected.

Basically it's fine for single-line text, but if you want multi-line text you'll need to manually figure out the absolute position for each line for the given angle, and how much will fit on each line.

Bitmap Element Fields

The following fields are specific to bitmaps:

File name

Enter the file name or use Browse to select it. Note however that the file must reside in the same folder as the current database, and it's not backed up with the database (basically just like Map files). Thus you may need to copy any files used to all computers using Campground Master.

The bitmap image file must be in a specific format for Campground Master to read it:

Windows Bitmap (.BMP) with RGB encoding, in either 16 or 256 colors

Note: The 16 above refers to colors, not "bits" -- a 16-bit format will not work. In terms of "bits", it must be 4-bit or 8-bit format.

If the image is not in this format, an error will be shown when attempting to load the image. Note that an RLE-encoded (run length encoded) bitmap cannot be used, it must be RGB encoded. If your image is not in this format, use an image editing program to change the format, such as the Windows "Paint" program (see Start / Programs / Accessories for the Paint program). When saving the file, use File / Save As and be sure to change the File Type to "256 color Windows BMP" (wording depends on the specific application, but look for "256" and "BMP" or "bitmap"). In some image programs, like Paint Shop Pro, you need to use the "Decrease # of colors" option to make it a 256-color image, and then save as a Windows BMP file.

Bottom / Right

Bitmaps must have a bottom and right boundary. This indicates the area on the Form that the image will occupy, and if the original image is not exactly that size then it will be stretched to fit in this space (height and width are stretched separately, which can distort the image).

The same Bottom / Right options are available here as for Region elements, so refer to those above for details.

However there are a couple special case for bitmaps -- if both a height and width of 0 is specified (e.g. using the Relative option), then the actual image height and width is used for that dimension. This allows a 1:1 image sizing, however this will be in "pixels" -- so it may appear smaller than expected on the page.

Another option is to use one of the other options for one dimension and a Relative / 0 option for the other. The image will be stretched to fit the non-zero height or width specified, and also stretched in the other dimension to keep the aspect ratio. For an example, if you want the image to be in the upper left corner and exactly 4 inches wide, keeping the correct aspect ratio, then use the following settings:

Top : Absolute / 0
Left : Absolute / 0
Bottom : Relative / 0 (which means keep the aspect ratio)
Right : Absolute / 4.0 (make it 4 inches wide)

Line Element Fields

The following fields are specific to lines:

Bottom / Right

Lines must have a bottom and right position to specify the "end" of the line. The line will be drawn straight from the top/left to the bottom/right, which can be any direction. The same Bottom / Right options are available here as for Region elements, so refer to those above for details.

Color

This determines the color of the line. An example is shown with the current colors selected. Click the Line button to change the color of the line. Note that the (background) is not actually used in drawing the line, but if the line is to be white then you can select a black "background" just so the example shows up.

Line width

Enter a number for the width of the line. Of course 1 is the skinniest. The number is generally in printer-dots, so the actual width in physical size may depend on the printer used.

Box Element Fields

The following fields are specific to boxes:

Bottom / Right

Boxes must have a bottom and right position to specify the other corner of the box. The same Bottom / Right options are available here as for Region elements, so refer to those above for details.

Color

This determines the color of the outline of the box and the fill color. An example is shown with the current colors selected. Click the Outline button to change the color of the line around the box, and the Fill button to change the interior filled color of the box.

Line width

Enter a number for the width of the outline of the box.

Transaction Table Element Fields

The following fields are specific to transaction table elements. Note that for character-position format Forms, only the Bottom/Right and Table Type fields are available and the narrow paper format option is assumed.

Bottom / Right

Transaction tables must have a bottom and right position, similar to regions, which specifies the bounds of the table. The same Bottom / Right options are available here as for Region elements, so refer to those above for details.

Font / Shrink to fit

You can choose the font as well as the shrink-to-fit option just as for text elements above. Note however that the shrink-to-fit option applies to each cell of the table individually, not the table as a whole. Also, the font attributes for bold, italic and underlined cannot be chosen for table.

Table Type

There are four different types of tables available (only two of them can be used for character format Forms).

Standard receipt -- The basic receipt-type table used for most receipts, invoices, etc., where the charges and discounts are shown on the first section, then taxes, then any credits, and finally any payments.

Register-style statement -- In this format, the transactions are shown in their original order, with columns for Charges, Payments, and Balance after each transaction.

Credit card slip -- This is designed to just show the credit card payment -- it will only show the most recent payment transaction on the slip with the total amount paid.

Purchase order -- This is for use only in Point of Sale purchase orders, where it uses purchase order transactions instead of customer transactions.

Narrow paper format

This flag is generally for 3" receipt printer output where the space is limited, but can also be used for E-mail forms if you don't want the table very wide. Note that if you do not select this option with an E-mail form (or even if you do for that matter), make sure that you have the Fixed Pitch option selected for the Form. It uses two lines for transactions, with the transaction description on one line and the quantity, each and total on a second line. The total will be right-justified according to the number of columns (or boundary of the table element).

Grid lines

Select this option if you want grid lines for the table. Don't forget that this can make receipts print much slower on ink jet printers.

Shade / color cells

Select this option if you want the Total column background shaded grey and the Total / Balance label in a black background. Don't forget that this does take more ink.

Shrink to fit more lines

This option allows it to use an overall smaller font for the table as the number of lines increases, so more lines can fit on a page. It's more efficient than printing multiple pages while allowing short receipts to have larger text, but it does make them less consistent. When this is selected, you also specify the minimum font size to use. It will shrink the font when needed to fit the rows within the table's area.

Max rows / page

You need to specify the maximum number of that can be printed rows per page. If the number is too high, transactions may be cut off or overlap text at the bottom of the page. Since some receipts may have a lot of "extra" stuff pushing down the transactions or appearing below it (like credit card info, "Additional sites", or multiple Receipt #'s), it's best to enter a lower number and let it print multiple pages even when there's some extra room.

Note that if the Shrink-to-fit option is enabled, assume that the smaller text size will be used by the time it reaches the maximum, and do some testing to see how many you can really fit with the maximum amount of "other" stuff printed (resulting in the smallest area available for the table).

Date / Qty / Each / Total widths

Enter the width desired for each of these columns. You may enter 0 for the Date width to exclude that column, but the other columns will always be included. You could enter 0 for their widths, but some remnants would still remain.

Note that for the Register-style statement, there is no Qty or Each column so this information is added to the Description, like "(6 @ \$10.00)". The Each width is used for both the Charges and Payments columns, and the Total width is used for the Balance column.

For E-mail forms and 3" receipts with Character positioning instead of Variable (inches/mm's), the widths specify # characters. Also note that the element width as defined by the Left and Right parameters will be used as the total width of the table. The recommended widths for E-mail would be 0 for Date, 6 for Qty, 10 for Each and 12 for Total.

Note that if the "Narrow paper format" option is selected for the table, these options will not be available as it uses a specific formatting.

You'll notice that there's no setting for the Description column -- the Description column will use any of the table's overall width left over after sizing the other columns.

Form Selection Dialog

A general Form Selection dialog is used in many places throughout Campground Master, typically for selecting a Form to print (e.g. from Find Reservations, Customer Details, Sites Setup, etc) or for selecting an E-mail format to use (from Transactions / Send E-mail Form).

In some cases, the Form Selection dialog will also have an option at the top to print a Grid format instead of a Form. This will typically print a list of fields for the current record (e.g. if invoked from a single-record dialog like Edit Site or Customer Details), or it will print the entire list of records being shown (e.g. if invoked from a multiple-record dialog like Find Customers).

If the grid option is not selected (or not available), then a drop-down list will contain one or more Form types to choose from. When a Form type is selected, any available Forms of that type will be shown on the list below. Just double-click on that Form (or select it and click the OK, Print, or Use button as appropriate) to use that Form.

There may also be an Edit Form button available if the current operator has sufficient access permissions to edit Forms. This allows you to edit the Form and then come back to print it again, without going back to the Maintenance functions.

Note that if Print Preview is enabled for receipts (through Printing Options), then of course it will show a preview of the Form when the Print button is clicked. An added benefit is that if you Cancel the preview instead of Printing, you'll still be in the Form Selection dialog where you can choose another Form, or Edit the Form and try again.

For E-mail forms, there will be an option to Preview before sending. If this is checked, then when you click OK it will open the E-mail sending form where you can preview and edit anything about the E-mail before sending it.

Also, if an E-mail form is selected that includes a Transaction table then there will be options at the bottom to select which transactions are printed (the same as are usually available for printing receipts).

Menus

Overview

Almost any of the drop-down or right-click menus in Campground Master can be customized with additional functions defined by expressions. Any number of menu selections can be added to the menus, which can also be organized in sub-menus any number of levels deep.

In addition, existing selections in the menus can be conditionally renamed or deleted to clarify or simplify the functions seen by most users.

Note that all menu customizations are done within the existing menu structure, modifying the standard menus -- it's not possible to create a completely "new" menu, simply because the program wouldn't know when or where to show it. However you can modify the very top menu bar, which means you can add a new drop-down menu to it (as well as add sub-menus in any of the drop-down menus), and you can modify almost any of the right-click menus in the system to add functions or sub-menus.

Menus Setup

To modify a Menu, go to Maintenance / Advanced Customizations / Menus. This opens the Menu Setup dialog, which lists all current Menu Definitions and has the typical functions for Adding, Inserting, Editing, etc. Note that while there are functions to Move Up and Move Down, a Menu Definition's position in the list does not usually affect the functionality. However if you create multiple definitions which modify the same menu, then the order in the list can determine the position of any new Menu Items added to the menu.

You can also Export one or more Menu Definitions to a text file, or Import Menu Definitions. This is primarily used for importing Menu Definitions created by the software provider, though it can also be used to transfer them between multiple databases.

Note: We refer to the entries as "Menu Definitions", but they're not actually "new" menus and don't even necessarily add anything to a menu (it could just modify the text of an existing selection in a menu). A Menu Definition is simply a list of "Items" to change in a specific menu, where each "Item" defines some change to the selected menu. The change could be to add a new selection in the menu which performs an "Action" when it's clicked, or the change might just be a command to remove or rename an existing selection, or it could be a complete sub-menu structure.

Menu Definitions cannot have duplicate names (this is primarily just to avoid confusion during setup). If you make a Copy of a Menu Definition, text like "(copy 1)" will be added to the name to make sure it's unique. Of course you can change this to be more appropriate. Duplicate checking for the names is not case-sensitive ("My Menu" is considered the same as "my menu").

Some common modifications are described below, to give you an idea of what can be done.

Removing menu selections (e.g. based on access levels)

While most functions in the menus can have their allowable access level changed through the standard Access Levels setup (Maintenance / Park Setup / Access Levels), this will only disable the menu selection rather than remove it from the menu. If you prefer to remove the disallowed functions, in order to simplify the menus for your users, then you can do it through the Menu Definitions.

To disable a menu selection, Add a Menu Definition for the appropriate Base menu. Then in the Edit Menu dialog, Add a Menu Item. In the Edit Menu Item dialog, select "Remove selection". Now select the option to find the selection by "ID/Command", and choose the menu selection from the large drop-down list.

Now set the Condition expression for when to remove the item. (If the Condition is blank, it will always remove it.) For instance if you only want to remove the selection if the current operator has a low access level (e.g. non-administrator), then you would enter a Condition expression like this (note that access levels are 0 to 5, where 0 = Guest and 5 is Administrator):

```
FieldValue(CurrentOpRec(), "Oper_Access") > 4
```

You can add as many Menu Items as needed in the same Menu Definition, to remove other items in the same menu.

Renaming menu items

If you prefer to use different text in the menus, either for clarification or to localize it to your language as much as possible, you can use the same procedure as described above for removing items. The only difference is that you would select "Rename selection" instead of "Remove selection" as the item type, and you would probably not have a Condition. Then just enter the new name in the Selection Name field.

Adding new functions to a menu

While the possible actions are limited by what can be defined with Expressions, there are many expression functions available for typical operations that will probably do anything you would want to do.

For instance there may be something you do often that takes several steps, which could be simplified by adding a custom Action to a menu which does it all at once. Or you might need to do some complex manipulations with the data on a regular basis and output that to a file -- this could be done with a Script, and adding a Menu Item somewhere to execute the Script makes it easy to perform the function whenever you need to. Likewise, you could read a file and process the data in a Script, such as reading the output of a phone system and adding the charges to the appropriate reservations.

Remember that right-click menus will have the context available for the expression defining the action, so for instance you can access the specific reservation that was clicked on. Top-level menus don't have any context to work with, but potentially some very complex actions could be created through scripts -- for instance to scan the entire database for a certain condition and show that information in a pop-up window or even a custom Dialog.

As a quick example, lets say that you want to add a command to the right-click menus to send a simple "Thank you for staying" E-mail (e.g. you could do this whenever you check them out).

First Add a Menu Definition for the appropriate Base menu -- in this case, "Right-click - Reservation, on other views" so it appears in the Departures tab view (you could do the same for the Rack right-click menu). Then in the Edit Menu dialog, Add a Menu Item. In the Edit Menu Item dialog, select "Execute Action". Enter an appropriate Selection Name, like "Send Thank-you E-mail".

Naturally this only makes sense if the customer has an E-mail address, and lets assume we also don't want this selection to appear in the menu until after the Check-out has been done. We can add this Condition so that the selection only appears when needed:

```
Cust:Cust_Email != "" AND Resv:Resv_Status = "Checked Out"
```

Now add the Action Expression, which will use the SendEmail function. (Note that this only works if you have the SMTP E-mail settings configured -- see Online Setup.) Obviously a real message would be longer than the one below, and you may want to include some fields from the reservation in it to personalize the message, but this should give you the general idea:

```
SendEmail(.T., "", "", Cust:Cust_First_Names, Cust:Cust_Email,  
"Re: Your recent stay", "Thank you for staying with us. Come Again!")
```

Save that Menu Item and you'll be back in the Edit Menu Definition dialog. Here you might want to fill in the "Insert at position" field so that the item you just added doesn't go at the very bottom. For instance, a value of 8 should put it right after the Check Out function on the Departures tab. Then Save the menu definition.

Editing Menus

The Edit Menu Definition dialog is shown when adding or editing Menus from Menus Setup.

Here you can view and edit all of the Items in a Menu Definition. There are a few fields you edit directly here, and the rest of the dialog lists the Menu Items.

Menu Definition Name

The name should be descriptive enough for identifying the Menu in Menus Setup, but that's generally the only place it's used. Each Menu Definition must have a unique name (which is not case-sensitive).

Enabled

The Menu Definition can be disabled by unchecking this box, so that it does not get processed. Note that if it's disabled, it doesn't just mean that the items added to the menu are disabled (greyed out) -- it means that the Menu Items in the definition won't be processed. Therefore it won't modify the base menu at all, as if the definition is not even there.

Modify Base Menu

Each Menu Definition is simply a list of things to do to an existing menu, so you need to select which menu it will modify from this list.

Main menu definitions can modify the top level menu (the menu bar across the top) or any one of the drop-down menus from there. Note that only the direct (first-level) drop-down menus can be selected, so any additions to the menu can only be made to that level. Of course you can add your own sub-menu at that level, and the sub-menu can contain any number of levels beneath it. However you can't add an item directly inside the Printer Setup under the File menu, for instance.

Note that while you can't add new selections (e.g. Actions or Sub-menus) at lower levels, it's still possible to modify existing selections at any level in the menus. For Remove or Rename item types you can choose the menu selection (ID) at any level below the base menu. So for instance you could completely remove all Printer Setup selections for non-administrator users.

Most right-click menus can also be selected as the Base Menu to be modified. Some right-click menus are specific to a particular view (e.g. for the Rack or Map) because the conditions there are unique, while the other views and situations are more general -- those base menu selections will affect the menu on any of the other tab views. For instance the same "Transactions" right-click menu is used for any view where a Transaction is selected, e.g. in the Transaction tab view and any user-defined Query based on Transactions.

Context for Expressions

Any right-click menu will have some context information available for the expressions in its Menu Items. Naturally the information available depends on which menu is the selected as the base, and in some cases the record selected when right-clicking will determine the context available.

For instance in a Transactions menu, **ThisTran()** will always be available, plus there might be **ThisCust()** and **ThisResv()** context info if the transaction is for a customer or reservation. A Customer menu will only have **ThisCust()** available, and the right-click for queries of "Other record types" will just have the generic **ThisRecord()**.

On the Rack, **ThisDate()** will be available for the cell clicked (and **ThisPeriod()**, if applicable, when viewing Scheduled reservations).

The Cross table Query menu will have a list of records "included" in the clicked cell (e.g. used for the calculation in that cell), so **ThisRecList()** and **ThisRecCount()** are available to access those. For List Queries and list-type tab views (Arrivals, Transactions, etc.), **ThisRecList()** and **ThisRecCount()** will reference all records being shown in the view (e.g. all reservations in Arrivals, all transactions in the Transactions tab, etc.). For a menu on the Map view, this list will be a list of the reservations in the site clicked on, for the date range shown. There is no context list available for menus on the Rack tab view.

The context functions **ThisFromDate()** and **ThisToDate()** can be used to get the From and To dates selected in the tab view or query report.

Menu Items List

A list of Menu Items appears on the Edit Menu Definition dialog, as well as on the Edit Menu Item dialog if the Menu Item is a Sub-menu. It operates the same way in either place, since a Sub-menu Item is essentially a Menu-within-a-Menu.

Menu items are actually "Item" records linked to the Menu (or sub-menu item), so this list shows those linked item records. As with most places where record lists are manipulated, the typical functions are available to Add, Insert, Edit, Copy, Delete, and Move items in the list. In addition, there are a few special functions as described below.

The item list shows the Condition and Text of the items, but depending on the item there's no guarantee that either one of these will be filled in. So putting in good Notes for the items is recommended.

Note that the text in some columns may be truncated (with "..." at the end). This is done automatically to limit the column widths and keep long text from making the other columns hard to find. (Even if the columns or the whole dialog is enlarged, it won't show these fields any longer here.)

Menu Item Order

When a Menu Definition is processed, the items are processed one after another in the order they appear in this list. Any Sub-menu items are "recursively" processed -- that is, all of a sub-menu's sub-items are processed before moving on to the next item at the same level (more is explained about "levels" below). While this in itself doesn't always make a difference, the order of items in a Menu Definition determines the order they're added to the menu (assuming the item isn't just a Rename or Remove item).

Expand Sub-menus

As mentioned above, a Sub-menu item is like a Menu within a Menu. As such, a sub-menu has a list of items of its own that are relative to that sub-menu. This can include another sub-menu, and so forth, resulting in multiple "levels" of sub-menus, each with their own list of items.

By default, the Edit Menu dialog or Edit Item dialog for a sub-menu will only show the items linked directly to it -- i.e. the current "level" of items.

However if you check the Expand Sub-menus box, all sub-menus at or below the current level are expanded into a tree-like list. This allows you to see all items in the entire Menu Definition (or current sub-menu) in a single list. To make it easier to read, each level will have a "--->" prefix and will be indented according to the depth, like a tree view. Also, each level will be shaded differently.

You'll notice that some functions are not available in expanded mode. You can't Insert or Move items, because it can't handle the multiple-level complexities of this. However you can Copy items from any level (the new copies will always be placed in the current level). You can also Edit an item from any level, which is the primary reason for expanding the list -- you can quickly locate the item of interest and edit it directly without going through each sub-menu above that. (Don't forget that double-clicking an item in the list also does the same thing as Edit).

Import and Export Items

These functions will import or export any selected items to a CSV (text) file. The main purpose of this is to copy the items to a different Menu Definition or to a different level (sub-menu) of the Menu Definition. You can also export commonly used sets of items, for importing to Menu Definitions you create later. Basically it's like doing a copy/paste of items, but going through a file instead of just the clipboard. Note that it's not the same as the import/export function for a complete Menu Definition -- it's strictly for copying or moving selected items. However if an item is a Sub-menu, then all of the items contained in that sub-menu are also exported (recursively to any level), and of course they would be imported intact the same way.

When exporting, any items visible in the list can be exported (even if Expanded as described above), but they must all be of the same expansion level. You cannot select some items in one level and some items in another level to be exported at the same time.

When importing, all items imported are placed in the current level (regardless of expansion). For instance if you're editing a sub-menu, then all imported items are added to that sub-menu. If you're editing the Menu Definition (the top level), they are added to the end of the definition. Careful manipulation of importing and exporting items allows you to move items around between levels, for instance to move some items to a higher or lower sub-menu level.

Editing Menu Items

The Edit Menu Item dialog is shown when adding or editing items from the Edit Menu Definition function. It's also used for adding or editing sub-items, from a Sub-menu item's Edit Menu Item dialog, so you could potentially be multiple levels deep into the same dialog.

Here you edit all of the components of a Menu Item. This one dialog is used for all types of items, even though different information is needed for each type. To help avoid confusion, it will only show the fields that apply to the item type that's currently chosen. Choosing a different Menu Item Type will completely change most of the fields available on the dialog.

The common fields available to all items are described first, followed by the type-specific fields for each item type.

Menu Item Type

The item type defines what will be done to the base menu -- either adding something to it (an action, separator or sub-menu) or changing something already in it (remove or rename a selection).

Execute Action -- This adds a selection to the menu, which executes an expression when the selection is clicked on.

Sub-menu -- This adds a selection which doesn't do anything itself, but opens another menu. You also define all of the selections which will be in that sub-menu.

Separator -- This just adds a line in the menu, used for separating groups of selections.

Remove selection -- This will completely remove an existing selection from the menu.

Rename selection -- This will change the name of an existing selection in the menu.

Condition Expression

All Menu Item types can have an optional condition expression. If a condition is entered, this determines whether the item is processed, e.g. whether the selection is added or not, or whether the selection is removed/renamed or not. It doesn't just disable the item (that's done by access level -- see below).

The condition expression must return a True or False boolean value. If used for a sub-menu, it naturally affects all sub-items too (the entire sub-menu is only added if the condition is True). To edit the condition expression, click on the text box or click the Edit button next to it. The Expression Creator dialog will be used to enter the expression.

Notes

You can add Notes to any item to help clarify its use. The notes will only show up in the list of menu items (the user will never see the notes).

Execute Action Items

Action Items are the main part of a menu -- the selections that actually do something useful. Anything you see in a menu that's not a sub-menu or separator is an "Action" item, whether it does something immediately (e.g. Save the database file) or opens a dialog prompting for more information (e.g. Log In).

Access Level

Select the lowest access level that should be able to do this action. If the current operator does not have this level or higher, the selection will still be in the menu but it will be disabled (greyed out).

Menu Item Selection Name

This is the text that will appear for the action item in the menu. You can either enter static (non-changing) text, like "Delete reservation", or you can create an expression such that the menu text will change depending on the situation or the record in question (e.g. "Extend by 1 month (to April 30)").

You need to select which way you want to enter the selection name (click one of the radio buttons), and then the appropriate entry field will be shown. If it's static text, then just enter it in the Selection Name field. If you choose to enter it as an expression, the Selection Name box will be greyed out -- to edit the condition expression, just click on the greyed-out box or click the Edit button next to it. The Expression Creator dialog will be used to enter the expression.

Underlining Hot-key letters

You can specify which letter is underlined, to be used as a hot-key for the menu selection, by inserting an ampersand ("&") in the text. For instance if you enter "Delete re&reservation", the "s" will be underlined and will be the hot-key, and it will be shown as "Delete reservation". Then in the resulting menu you can just press "s" on the keyboard instead of using the mouse to click on the selection in the menu.

Be careful about underlining a letter that's already used as a hot-key. If there's more than one selection in the same menu that uses the same hot-key letter, pressing that key will only move to that selection (highlight it) -- it won't execute it. Pressing the key again would move to the next one with that hot-key, etc.

Note: If you actually want to show "&" in the menu, like "This & That", then you need to use two of them in the selection text: "This && That". This tells Windows that you want to show the & instead of underline the next letter.

Important: There's an option in Windows XP to hide the underlines until you press the Alt-key, and in Microsoft's wisdom they seem to have enabled that option by default in some cases (why confuse the user with all those underlines, right?). So if you don't see any letters underlined in the menu, just press the Alt key and the underlines should show up (this applies to all menu selections, not just the ones you add). You can also disable this option in XP by going into Desktop Properties (right-click on an empty desktop area), click the "Appearance" tab, click the "Effects" button, and uncheck the "Hide underlined letters" option.

Action Expression

This defines what will actually happen when the menu item is selected. Simply put, this expression is executed when the item is clicked. The result of the expression is not used, so it doesn't have to return any particular type of value. To edit the action expression, click on the text box or click the Edit button next to it. The Expression Creator dialog will be used to enter the expression.

Naturally the expression should "do" something useful. Many useful functions are available to do things like show a message, open Queries, send E-mail, print Forms, open Dialogs, or even just execute another menu command. To browse some of the possible actions, select the "User interaction" function type (through Insert Expression Element, in the Expression Creator dialog).

Of course it doesn't necessarily have to do anything visible -- for instance you can just set a field value. But we recommend that you always show some indication that the action was performed, e.g. with a **MessageBox()** confirming the action and perhaps showing the details or results, so the operator knows that something actually happened and that they clicked the right thing.

If you do anything complex, e.g. more than one function, then it may be a good idea to create a Script for it and then just use **CallScript()** to call the Script from the Action expression here.

Note that for right-click menu items, there may be context information available -- for instance the **This()** function may give the reservation, site or transaction that was clicked on, and for the Rack there will be **ThisDate()** and **ThisPeriod()** context.

Sub-Menu Items

A sub-menu is used to organize menu functions in logical groups, and to keep each level of a complex menu from getting too long. A sub-menu will have a name in the menu just like an action item, but clicking on it will simply open another menu (usually to the right of the sub-menu item, if there's room for it there). A right-arrow indicator will be added to the right edge of the menu automatically (by Windows), to indicate that it will open another menu.

A sub-menu item needs a Selection Name to be shown in the menu, which is described above for Execute Action items (see "Menu Item Selection Name" above).

A sub-menu also needs Menu Items of its own, so a list of Menu Items will be shown here with applicable editing commands, just like the Edit Menu Item dialog. See the previous section about the Menu Items List for details.

Separator Items

A separator is just a line in the menu used for organizing selections into groups, so there's no more information needed for a separator.

Remove Selection / Rename Selection Items

These item types are used for modifying existing selections in a menu. Generally this is done for standard selections that the program includes, but it's also possible to do it for selections that you've add yourself (though it's better to handle this with the Condition or Selection Name expression of the original Menu Item definition).

If it's a Rename Selection item, it needs a new Selection Name that the original menu selection will be renamed to. This field is described above for Execute Action items (see "Menu Item Selection Name" above).

Finding the Item to remove/rename

For both Rename and Remove selection items, it needs to know which item to act on. You can have it find the item by name or by its internal ID/command, so first select which way you'll find it.

Whenever possible, e.g. whenever it's for a standard menu command, choose the ID/Command option and select the appropriate command form the list. The list shows all menus in the system that can be modified, with all sub-menu command items. Note that the "ID to remove" will be shown for the selected item, but only for reference -- it cannot be modified directly.

Tip: You can use this to find out the command ID of a menu item, for instance if you want to execute the command through the expression function **MenuCommand()**.

While you could choose to find the item by name, that might not always work -- sometimes a selection's name is changed based on the condition (e.g. "Check out" vs. "Undo check-out"), and it's also possible that the menu selection name may change in future versions of the software (but the command ID should never change).

There are some cases where you do need to find it by name. If it's an item you added through a Menu Definition yourself, the ID is not known at this time so the name must be entered. Also, sub-menu names don't have an ID, so they would have to be located by name. For instance if you wanted to rename the "Park Setup" sub-menu selection under Maintenance, you would have to find it by name.

Note that in either case, the "search" for the selection is recursive -- it will look at all levels of sub-menus below the base menu of the Menu Definition until it locates the selection to be renamed or removed. Of course if it doesn't find a match, then nothing happens.

Important: When searching by name, any ampersand characters ("&") in the menu selection will be ignored. For instance if the original menu selection name is "&File" so that it's shown as "File" in the menu, you should only enter "File" in the text to search for.

Dialogs

Overview

Through the Dialogs Setup functionality, several of the main data entry dialogs can be customized to a large extent -- new entry fields can be added to a dialog (e.g. for new data fields added to a table through Data Field Definitions), existing controls can be disabled, deleted, moved or renamed, and the dialog can be enlarged to accommodate new fields. Additional actions can be taken when any control is activated (e.g. when a button is clicked, edit field changed, etc.), supplementing the normal program operation with your own special functionality.

In addition, completely new dialogs can be created for displaying information or for data entry. A custom dialog can be displayed by calling the Expressions function **DlgOpenUserDialog()**, for instance when a new button is clicked on another dialog, or through a custom Menu Definition or when an Event Action is triggered.

As with all advanced customizations, this requires a rather technical understanding of the system. **It must also be emphasized that modifications to existing Dialogs are more "dangerous" than most other customizations because they change the operation of the program, and can also cause a system malfunction.**

Dialogs Setup

A "Dialog Definition" is a list of instructions for modifying a particular dialog. Create a Dialog Definition for each system dialog that you want to modify, or for each new dialog you want to add.

Note that only one Dialog Definition can be enabled for each system dialog, e.g. for the Edit Reservation dialog, but the definition can contain as many Dialog Elements as needed to make all of the customizations you want.

To create a Dialog Definition, go to Maintenance / Advanced Customizations / Dialogs. This opens the Dialogs Setup dialog, which lists all current Dialog Definitions and has the typical functions for Adding, Editing, etc. Since the order of the definitions doesn't affect any functionality, there is no Insert command -- but you can Move the dialogs up or down in the list if you want to rearrange them.

You can also Export one or more Dialog Definitions to a text file, or Import Dialog Definitions. This is primarily for you to import Dialog Definitions created by the software provider, though it can also be used to transfer Dialog Definitions between multiple databases.

Dialog Definitions cannot have duplicate names. If you make a Copy of a Dialog Definition, text like "(copy 1)" will be added to the name to make sure it's unique. Of course you can change this to be more appropriate. Duplicate checking for the names is not case-sensitive ("My Dialog" is considered the same as "my dialog").

Expression Functions for Dialogs

Most expressions in dialog element definitions need to do something with the controls in the dialog -- such as get and/or set a dialog control's current value, change which control has focus, modify controls or perform other functions within the dialog. A whole set of functions are available for this, all of which start with the letters "**Dig**". Refer to the function types "User-defined dialogs" in the Expression Elements dialog (through the Insert Expression Element function of the Expression Creator) for all of the functions available for accessing and working with dialog controls.

Note that there are separate sets of functions for new controls (added by the dialog definition) vs. standard controls (in an existing dialog), because new controls must be referenced by name whereas existing controls must be referenced by a numeric control ID. Be sure to use the functions with "User" in the name to access a new control added in this dialog definition, and use the function without "User" in the name for standard controls that are in the existing dialog.

"Changed" Flag

Each dialog keeps track of a "changed" flag so that it knows whether anything needs to be saved back to the record when it's closed. When you add a new control to a dialog, the program already handles this flag internally for obvious changes, e.g. when the value of the control is changed. However there may be times that you need to change something internally and need to let the dialog know it. There is an expression function **DigSetChangedFlag()** for setting the "Changed" flag when needed. There's also a function to get the current status of the flag, in case you want to see if something has changed before performing an action of your own.

Opening a Custom Dialog

Once you've created a new dialog, you need some way to open it. Use the function **DlgOpenUserDialog()** with the dialog name to open the dialog. You can also give it the record to be used (in context). You might want to do this from a Menu definition, an Event, or from a button action in another dialog.

This function returns True if the "Save" or "OK" button is clicked (or more specifically if the **DlgClickSave()** function is called within the dialog expressions), or else it returns False if "Cancel" is clicked or if it's closed with the "X" button.

Editing Dialogs

The Edit Dialog Definition dialog is shown when adding or editing Menus from Dialogs Setup.

Here you can view and edit all of the Items in a Menu Definition. There are a few fields you edit directly for the definition, and the rest of the dialog lists the Dialog Elements.

Dialog Name

The name should at least be descriptive enough for identifying the Dialog in Dialogs Setup, but if it's a new dialog rather than an Add-on, then this name will also be the title of the dialog when it's displayed and also the name used to open it from the **DlgOpenUserDialog()** function. Each Dialog Definition must have a unique name, whether it's an Add-on or not. The name is not case-sensitive, so "My Dialog" is considered the same as "my dialog".

Add-On

To define changes or additions to a standard dialog, check this box and select the appropriate dialog from the list. To create a brand new dialog, leave this box unchecked.

Only one Add-on Dialog Definition can be Enabled for each standard dialog in most cases, e.g. for the Reservation Details dialog -- but you can actually create multiple definitions for the same dialog as long as only one is Enabled at a time. Thus you could experiment with a new definition without taking it "live" by changing which one is enabled.

There is a special dialog template called "Edit Generic Record", which is used as an Add-On but must also have a Base Table (see the "The Edit Record Dialog" section for details). This is the one case where more than one Add-on of a dialog type may be used (and enabled), but each one must have a different Base Table.

Enabled (Add-on only)

An Add-on Dialog Definition can be disabled by unchecking this box, so that it does not get processed. This is only applicable to Add-on dialogs, because non-add-on dialog definitions aren't automatically used (only opened explicitly through an expression function). If an add-on dialog definition is disabled then it won't modify the base dialog at all, as if the definition is not even there.

Base Table (non-Add-on only, or Add-on for the "Edit Generic Record" type)

A Dialog Definition that's not an Add-on needs to have a Base Table selected (any Add-on has a base table already defined by the dialog it's modifying). Select the table for the type of record will be shown (and possibly modified) in the dialog. In general, any new dialog is assumed to be operating on a single record of the selected type, and this context record is specified when the dialog is created through the **DlgOpenUserDialog()** function.

The Base Table selection also affects which fields are available in the Quick-Add Fields function (described in the Dialog Elements List section to follow).

Width & Height

The units for these values are screen pixels, so you should know the resolution of the screen (or screens) to be used. As a general guide, Campground Master typically uses dialogs that will fit on 640x480 screens, but some will be sized for 800x600 screens automatically if the current resolution is high enough. Since most modern systems have a resolution of 1024x768 or higher, it's possible that you can use much larger dialogs to allow for more fields.

Note: If you're using Campground Master on multiple computers, be sure to design for the **lowest** resolution in use, otherwise the dialog may not be completely visible on some displays. Don't forget to take into account any computers you use as backups or off-season work, for instance your laptop computer. You can check the resolution on any computer by right-clicking on the Desktop and selecting Properties, then go to the Settings tab.

For Add-on dialogs, the Width & Height specify how much the original dialog is enlarged, if at all. You can enter 0 for either or both values if you don't need it enlarged for the changes you're making.

For non-add-on dialogs, the Width & Height specify the entire size of the dialog. This defaults to 600 x 400 by default, to make sure it fits on the smallest typical display (640x480, allowing for margins, task bars, etc.).

Quick-Add 'Save' & 'Cancel' buttons (non-Add-on only)

When you create a new dialog, you usually want to have Save and Cancel buttons on it for saving or canceling the changes to the data fields. Clicking this button will automatically add Dialog Elements for Save and Cancel functions in the typical upper-right positions in the dialog. The elements added will include the Action expressions needed for typical functionality.

If you decide to change the size of the dialog after adding these, you can delete the previous Save and Cancel elements and then click this button again to add them in the correct position for the new size. (Or you could just edit the Left positions manually in the elements.)

If you add these before adding other Dialog Elements, then you might want to move them down to the bottom when you're done so they're the last things controls in the tab order (more on that later).

Save & Test Dialog

This function allows you to quickly test the dialog, or at least see the results of your modifications. This function can be used to test the dialog repeatedly without completely exiting the Edit function.

The appropriate host dialog will be opened (if it's an Add-on definition), or it will create and open your new dialog, using the first record of the appropriate Base Table type as the context record. This allows you to basically see where new items are positioned, what the data looks like, test its functionality, etc.

Be careful when testing, because any changes to the data in the dialog (or other functions activated) will be real changes!

Also be aware that it **does** completely save any changes you've made to the Dialog Definition as soon as you click the Save & Test button, so it negates any possibility of canceling changes you've made to the definition.

Dialog Elements List

A list of Dialog Elements appears on the Edit Dialog Definition dialog. Dialog Elements are actually records linked to the Dialog Definition, so this list shows those linked records. As with most places where record lists are manipulated, the typical functions are available to Add, Insert, Edit, Copy, Delete, and Move items in the list. In addition, there are a few special functions as described below.

The list contains several fields of the elements, but depending on the element type there's no guarantee that each of these fields will be applicable. So using good Notes for the elements can help later.

Note that some columns (e.g. any expressions) may be truncated (with "..." at the end). This is done automatically to limit the column widths and keep long text from making the other columns hard to find. (Even if the columns or the whole dialog is enlarged, it won't show these fields any longer here.)

Dialog Element Order (& Tab Order)

When a Dialog Definition is invoked, the items are processed one after another in the order they appear in this list. While this in itself doesn't always make a difference, e.g. for "modification" or "action" element types, the order of New Controls in the list determines the order the controls are added to the dialog. This in turn affects the "Tab order", i.e. the order in which the fields are selected in the dialog (get input focus) when the Tab key is pressed. In other words, for text input fields the order determines the sequence that the cursor moves from one input field to the next.

In addition, the order of controls on the dialog is important for hot-key use. For instance if you define a label for a text field as "&Name", so that the "N" is an underlined hot key, then the text input control for that field must be the very next element in the list so that the cursor goes to that field when **Alt-N** is pressed.

Finally, the order is important for Radio type controls since it affects their grouping. This is covered in more detail later, under Editing Dialog Elements.

Quick-Add Fields

This is a special function used to easily add the necessary Dialog Elements for entering (or modifying) database fields. You will be able to select multiple fields, and it will automatically add the elements (with appropriate labels for input fields) positioned in a neat column on the dialog.

First you will need to specify several parameters for positioning the entry fields. The defaults will be set for typical positioning, starting in the upper left of the dialog. You can leave these defaults alone and Continue, at least for the first batch, if it's a new dialog. However if it's an Add-on, or if you've already added some elements, then you'll probably need to adjust the starting left and top position. You can also adjust the vertical spacing (to put multiple fields closer together or farther apart), as well as the left position and maximum width of the entry fields.

Next, a list will be shown with fields for the appropriate table(s) for the type of dialog you're adding to, or for the Base Table of a new dialog. Select as many fields as you want to add in one column of input fields. If you need to add multiple columns, e.g. if they won't all fit in one column, then you need to do it in separate sessions of Quick-Add Fields since this function won't automatically wrap to another column -- it will continue adding elements even if they go past the bottom of the dialog.

While it will do some auto-adjustment (restriction) of the positioning specified based on the dialog size, you may still end up with fields that go off the end of the dialog. You might also end up with overlapping controls, since no overlap-checking is done. These can be modified individually, or you can delete all of the new elements and try again.

Import and Export Elements

These functions will import or export any selected elements to a CSV (text) file. The main purpose of this is to copy the elements to a different Dialog Definition. You can also export commonly used sets of elements for importing to Dialog Definitions you create later. Basically it's like doing a copy/paste of elements, but going through a file instead of just the clipboard. Note that it's not the same as the import/export function for a complete Dialog Definition -- it's strictly for copying or moving selected elements within a Dialog definition.

When exporting, only the elements selected are exported (they don't need to be sequential, e.g. you can use Ctrl-click to select each element to export). When importing, all imported elements are added to the end of the definition.

Editing Dialog Elements

The Edit Dialog Element dialog is shown when adding or editing elements from the Edit Dialog Definition function.

Here you edit all of the components of a Dialog Element. This one dialog is used for all types of elements, even though different information is needed for each type. To help avoid confusion, it will only show the fields that apply to the element type that's currently chosen. Choosing a different Element Type will completely change most of the fields available on the dialog.

The common fields available to all elements are described first, followed by the type-specific fields for each element.

Element Type

Select the type of element you want to add. The dialog elements fall into several different categories:

Add a New Control -- This adds a new "control" to the dialog, such as an entry field, text, checkbox, selection list, etc. Naturally the control is only added once, when the dialog is created, but any Action expressions in the elements are still active as long as the dialog is open.

Modify a control -- Elements can be used to rename, move, re-size or hide an existing control. These can only be done for standard controls on the dialog, not new controls that you add. Multiple elements can act on the same control, e.g. you can rename, move, and re-size the same control using 3 different elements. These elements are executed only once, when the dialog is created.

Action on input -- Data-entry types of controls can trigger an action when something is changed (when the text is changed, a box checked, etc). You can define an expression to be executed when the action is triggered, e.g. to do something when a button is clicked, or auto-format text as it's entered. This element can only be added for standard controls, since the Add New Control element already contains an Action expression for new controls. Any action elements stay active for the duration of the dialog.

Action on focus change -- This can be used to trigger an expression when a control gains or loses input focus (e.g. due to a mouse click or Tab to the next control). These elements can be defined for either standard controls or for new controls you add.

Action on data saved -- This element is triggered when data is saved to the record being edited. This is usually done when "Save" is clicked on the dialog, but other things can trigger it too. This element can be used to do special validation of the data, for instance.

Action on dialog initialization -- This element is triggered when the dialog is being initialized. You can use this element to perform any other actions you want to when opening the dialog. Note that this is only executed once, not for each record change (e.g. if changing records in Reservation Details), so the record context is not necessarily useful. For instance It could be used to do initial validations, modify controls, or show messages.

Condition

This optional expression determines whether or not the element is used, and must return a True or False boolean value. To edit the condition expression, click on the text box or click the Edit button next to it. The Expression Creator dialog will be used to enter the expression.

If the condition returns False, then the element is considered non-existent -- if it's for a New Control element, then the control won't be added. If it's for an element that modifies other controls, the modification won't take place. And if it's for an action type of element, then the action will not take place.

Note that for action elements, this condition is checked only when the dialog is first created, not each time there's a possible trigger, so a condition based on changes in the dialog cannot be checked here. If you want the element to only execute an action if certain changeable conditions are satisfied at the time of the input or focus trigger, then you need to check these conditions within the Action expression.

Notes

These notes are for your reference, and will also appear in the list of elements. We recommend putting notes in especially for action type elements if the expression isn't obvious, but it's a good idea for any element that's not obvious so you can tell what's going on if you need to edit the Dialog later.

Context Available in Dialogs

There are some special considerations for the expression context in dialog definitions.

In most cases, the **ThisRecord()** context is obvious, e.g. it's the Site for a Site Details add-on, the Customer for Customer Details, etc. Likewise, in Reservation Details, you have the obvious **ThisResv()** context and also a corresponding **ThisSite()** and **ThisCust()** available.

For dialogs that aren't add-ons, the **This()** record is defined when you call **DlgOpenUserDialog()** to open it. In addition, any existing context would be inherited from the expression or script that it's being called from -- for instance, if you create a custom dialog that's called from a right-click menu function on a query or tab view, you have access to all of the query's context such as **ThisListCount()** and **ThisListRec()** for the list of records in the query, as well as **ThisFromDate()** and **ThisToDate()** for the dates selected in the query.

Note that in the case of Site Details, Customer Details, etc., while you do have the record context available, it's not guaranteed to be a real record in the database. For instance, when editing a customer, it will just be a temporary record except during the Action on Data Saved expression. So be careful not to assume that setting values in the record will stick (other than in the Action on Data Saved), or that the record itself will be saved (e.g. if they click Cancel when adding a new customer).

Additional context is available for add-on definitions for New Reservation / Assign Site. The context list accessed by **ThisListRec()** and **ThisListCount()** will have the list of sites currently selected. Also in New Reservation / Assign Site, when saving data (BeforeSaveAction), **This()** will be the Customer if creating a New Reservation, or it will be the Reservation if Assigning a Site. There is also a special function

ThisTempRec(), which will be a temporary reservation record with the current preferences selected, so you can act on the current selections before the reservation is saved.

In a New Reservation dialog add-on, if multiple reservations are created (multiple sites selected), then the OK/Save Expression for any controls will be executed for **each** reservation created, with the appropriate **Resv()**, **Site()** and **Cust()** context of the real, created reservation. This allows any fields to be saved to each reservation. (If they are Customer fields, it will probably set the value to the same customer multiple times but that should have no adverse effects.) Just be careful about doing things in the expression that should not happen more than once. However, if you added an "Action on data saved" element, that element's Action expression will still only be executed once. The context **Resv()** for that expression will be the "primary" reservation (the first site added).

In the Point of Sale Entry dialog, the **Resv()** and **Cust()** context may be available if a reservation or customer have been selected.

"Add New Control" Elements

New control elements are used to add new data to a dialog, either to show the value or to allow the user to change a value. You can also add your own buttons to the dialogs, perhaps to perform special functions or to open a new dialog for entering a lot more information.

Control Name

This is a name to be used for the control internally, but is not the text shown for the control. A control name should be unique within the dialog definition, so that it can be referenced in expressions (e.g. to set or save the field's value) and referenced in other dialog elements. It may also help to indicate the type of control in the name for easy reference. Typical control names might be "EmailButton", "LastNameEntry", "LastNameLabel", "SiteDirtyCheckbox", etc. Using multiple words without spaces like this also serves as a reminder that the Control Name is not the text that gets displayed, but if you prefer to use spaces then you may do so.

Note that the names may be case sensitive when referenced (e.g. "ButtonA" is not the same as "buttona"), though this is not guaranteed. It's good practice to always assume the case must match.

Control Type

Select the type of control from the list. Naturally the type of control determines what's shown on the dialog as well as what it can do, how it acts, what kind of action it triggers, etc., so familiarity with Windows controls is helpful. A brief description of each is given below.

- Static text - Simple text (not editable), which will wrap as needed within the control's size
- Edit text - A single line text input field
- Edit text multi-line - A multi-line text input field (but the Tab key goes to the next control)
- Edit text multi-line w/Tab key - A multi-line text input field, with Tab key support
- Edit text, Read-only - Similar to static, but has a box around it like an edit field
- Edit text multi-line, Read-only - Same as above, for multiple lines.
- Button - A clickable button with text in it.
- Check box - A square checkbox input field for yes/no or true/false values
- Radio button - A round check-button field for multiple-choice input values
- Date selection - A date input field with a drop-down calendar selection
- Date selection with checkbox - A date field that has a checkbox (unchecked = no date selected)
- Time selection - A time entry field, with up/down buttons
- List box - A multi-line list of items to choose from
- Drop-down list box - A list of items to choose from, in drop-down form

- Combo list box - Similar to a drop-down list, but any text can also be entered

Start of a group

This is generally only important when Radio button controls are added, since a set of radio buttons must be in a "group" to act properly. In particular, when one radio button of a group is checked, it will automatically uncheck any others in the group. Also, it allows the arrow keys to be used to select which item in the group is checked, and the Tab key will move on to the next control outside the group.

Every new control has this option checked by default. When adding radio buttons for a multiple-choice option, you should **uncheck** this for each button except for the first one. It's also important that the next control in the dialog element list does have this option checked, so that it knows a new group (not part of the radio group) is starting.

Left & Top position

Specify the upper left corner position of the control, in pixel units. The position 0,0 is in the upper left corner of the dialog. It's usually desirable to leave a margin of about 10 pixels, so the default starting position is 10,10.

Width & Height

Specify the size of the control, in pixel units. Note that for drop-down list boxes and combo boxes, the height specified is the maximum height after it's dropped down -- the control height when it's not dropped down cannot be changed.

Control Text

This is the text that will appear in the control by default for text controls, buttons, check & radio boxes, and edit controls. It's not applicable to date or time controls, or list & combo boxes. These types need to be "filled in" from an Initialization expression, for instance.

Initialize Expression

This expression is executed for each control, after the control is created and shown on the dialog. This is where you should "populate" the value of the field if it's a data field. You can also use this to set static text fields to a value that depends on the context record, for instance. To edit the expression, click on the text box or click the Edit button next to it. The Expression Creator dialog will be used to enter the expression.

There are **DlgSetUserCtrl...()** functions for each type of control, so you should use the appropriate expression to set the value of the control. Here's an example, setting an Edit control to the current value of the "# Adults" reservation field:

```
DlgSetUserCtrlText("# Adults Input", FieldText(ThisResv(), "Resv_Adult"))
```

For list and combo box fields, you'll also need to populate the list of selections, using **DlgAddUser...()** function calls. Here's part of an example for a Site Type list, including a blank entry at the top (assuming you want the option to leave it blank). Here the **Eval()** function is used so that many expressions can be executed in sequence, in order to add all of the necessary options:

```
Eval( DlgAddUserDropListText("Type Input", " "), DlgAddUserDropListText("Type  
Input", "Normal RV"), ....
```

If you're not sure how to handle a particular type of input, use the Quick-Add Fields function in Edit Dialog Definition to add a similar type of field. It will fill in an appropriate expression for you.

OK/Save Expression

This expression is executed for each control when the "Save" function is done for the dialog (e.g. when **DlgClickSave()** is called in a new dialog, usually done when the "Save" button is clicked). This is where you would get the final value of the control and put it into the data field of the appropriate record. To edit the expression, click on the text box or click the Edit button next to it. The Expression Creator dialog will be used to enter the expression.

It may be tempting to do validation here, but there's no way to abort the saving here if the value isn't valid. See the other element type, "Action on data Saved", for a good place to do validation. Of course if you just need to modify the value, e.g. convert the typed text to upper case, then you can do that here.

You should use appropriate expression functions to get the value of the control. There are **DlgGetUserCtrl...()** functions for each type of control. Here's an example, getting an Edit field for the "# Adults" reservation field and setting the data value:

```
SetFieldText( ThisResv(), "Resv_Adult", DlgGetUserCtrlText("# Adults Input"))
```

If you're not sure how to handle a particular type of input, use the Quick-Add Fields function in Edit Dialog Definition to add a similar type of field. It will fill in an appropriate expression for you.

There is a subtle but important issue when changing database field values -- the "Save" function is done only when it detects changes, e.g. when a change to an entry field is noticed. If you change database field values through scripting or any change to a record's value besides what's manually changed by the operator on the dialog entry field, you need to make sure you use `DlgSetChangedFlag(.T.)`, in case no other changes are made on the dialog entry fields themselves that would normally trigger a flush.

Action Expression

This is optional expression which will be executed when the control's value is changed by the user (e.g. a button or checkbox clicked, text edited, or a list selection changed). As with any expression, appropriate context will be available. To edit the action expression, click on the text box or click the Edit button next to it. The Expression Creator dialog will be used to enter the expression.

Control is NOT a data field

Usually when you add a control such as Edit Text, Check box, Drop-down List box, etc, it will be used for a database field. Thus any change to the field needs to be recognized as a "Data changed". However there are some cases where you use a field for some other function (e.g. a List Box used to just show a list of options to choose from). To avoid making the dialog think the database should be updated when the control is clicked on, set this option. Technically it wouldn't hurt anything if you never check this option, but using this option can help avoid extra "Save changes?" prompts when nothing has really changed.

"Modify Control" Elements

These element types, Rename, Move, Resize and Hide, allow you to change the standard controls of an existing dialog. These cannot be used with new controls you add, since all of this can be specified in the new control's element definition already.

Control ID

This specifies which dialog control will be modified. It must be entered as the internal ID of the control. To find out what the ID is for a given control, you will need to refer to the program's Help (press the F1 key when you're in any of the Dialog customizing functions and you'll find a link to the Dialog Control ID Reference near the bottom of the help screen).

Position, Size, or Control Text

Depending on the type of element, fill in the appropriate information -- the new Left and Top position for moving a control, or the new Width and Height for resizing a control, or the new Control Text for renaming a control.

"Action on Input" Elements

These element types allow you to perform some action when the standard controls of an existing dialog are clicked or the values changed (depending on the control type). These types of elements cannot be used with new controls you add, since the action expression is specified in the new control's element definition already.

Note that "Action on button click" is used not only for button controls, but also for checkbox controls and radio buttons. If the wrong type of action element is used for a control (e.g. a "button click" action for an Edit control), the results are unpredictable.

Any number of Action elements for a given control can be defined, and will be executed based on the order in the Dialog Elements list. However, note that any "Execute action before..." elements will be processed first, then the normal action of the control will be done, and finally any "after" elements will be executed (elements that do not have "Execute action before..." checked). If at any time one of the elements aborts the processing for that control (through the Abort option below), then it will also skip all remaining Action elements defined for that control.

Control ID

This specifies which dialog control will be modified. (See "Modify Control" Elements above for details.)

Action Expression

This is the expression which will be executed when the appropriate control change is triggered. As with any expression, appropriate context will be available. To edit the action expression, click on the text box or click the Edit button next to it. The Expression Creator dialog will be used to enter the expression.

Execute action before normal processing

If this option is checked (and an Action expression entered), the Action expression will be executed before any normal processing that might happen for the action. This may or may not be important, depending on what you want to do.

The "normal processing" refers to the internal processing that the program normally does when this action is triggered. In many cases it's nothing, e.g. when entering text for most fields. However in many cases there is something done such as validation of the value, or changing what other fields are visible. And of course any buttons clicked will do something important.

As an example, you might define an element to execute an action when the "+1M" button is clicked in Reservation Details. If you need to make sure it's OK to do this before allowing it, then you would check this "Execute action before..." option so you can do your check and keep the function from happening if needed). However if you want the normal action to take place first (updating the date) before executing your expression, then don't select this option.

Abort the operation which triggered this action

If this is checked, then the Action Expression should return a True or False (boolean) value. If the value is False, then any normal processing is aborted. Obviously this is only useful if you also check the option to execute your action before normal processing, since there's nothing to abort after the normal processing.

As an example, you can do some validation or prompt the user when a button is clicked (e.g. to Check In a reservation), which would naturally need to be done before the normal processing, and return False in your Action expression to abort the operation if you don't want it to continue.

"Action on Focus Change" Elements

These elements can be used to trigger an expression when a control gains or loses input focus (e.g. due to a mouse click on the control, or the **Tab** key pressed to get to the next control). These elements can be defined for either standard controls or for new controls you add.

As described for "Action on Input" elements, only the first applicable focus change element will be used for a given dialog control.

Control ID or Control Name

This specifies which control will be modified. If it's for a standard (existing) control, fill in the Control ID (see "Modify Control" elements above for details.) If it's for a new control, fill in the Control Name of the new control (which must match the Control Name in the new control element definition).

Action Expression

This is the expression which will be executed when the control loses or gains focus. To edit the action expression, click on the text box or click the Edit button next to it. The Expression Creator dialog will be used to enter the expression. The expression is always executed after the focus change actually happens (so for instance you can set focus somewhere else).

The focus change cannot be aborted, so the return value of this expression is not used.

"Action on Data Saved" Elements

For add-on Dialog Definitions, this element is triggered when data is saved to the record being edited.

For new dialogs, this is triggered when the **DlgClickSave()** function is executed. This is usually done in the Action expression for the "Save" button, so it will happen when "Save" is clicked on the dialog.

Action Expression

This is the expression which will be executed when the data is saved to the record being edited. Note that for add-on dialogs this isn't necessarily just when the dialog is closed -- for instance when used in the Customer Details dialog (Edit Customer), this is done whenever the customer being viewed is changed also, e.g. through the Next and Prev buttons.

To edit the action expression, click on the text box or click the Edit button next to it. The Expression Creator dialog will be used to enter the expression.

Execute action before normal processing

If this option is checked, the Action expression will be executed before any normal processing that the dialog does for saving -- generally this means before the data is actually saved into the record. Thus you can do any validation of your own before anything is saved, with the option to abort the changes before actually saving them.

If this option is not checked, then the Action expression is not executed until all of the normal "Save" processing is performed by the dialog, e.g. the data validated and saved.

Note that it is possible to have two "Action on Data Save" elements, one to be executed before and one to be executed after the normal processing.

Abort the operation which triggered this action

If this is checked, then the Action Expression should return a True or False (boolean) value. If the value is False, then any normal processing (validation and saving data) is aborted. Obviously this is only useful if you also check the option to execute your action before normal processing.

Dialog Control ID Reference

Base Dialogs ID Reference

When you're customizing an existing dialog (by creating a Dialog definition that's an "Add-on" to a base dialog), you may want to move, hide, or rename one of the controls that already exist on the standard dialog. To do this, you need to know the ID's of the existing controls. There's no guarantee that these ID's will remain the same in future versions, but we've included a reference of the ID numbers for the current version.

The dialogs that can be added-to are listed below. The control ID's of each dialog are not included in this printed documentation (partly because they can change as mentioned above), but you can find the details in the online Help (press the F1 key when you're in any of the Dialog customizing functions and you'll find a link to the Dialog Control ID Reference near the bottom of the help screen).

- Customer Details
- Reservation Details
- Site Details
- Park Setup
- Edit Vendor
- Edit Inventory Item
- New Reservation / Assign or Change Site
- Transactions (Unbound, Customer, or Reservation)
- Point of Sale Entry
- Edit Work Order

- Edit Journal Entry
- Edit Generic Record

Event Actions

Overview

Event Action definitions allow you to "inject" functionality into Campground Master by trapping, or intercepting, a specific change or activity in the program. There are many pre-defined "Events" in the program that can be intercepted and acted upon, and you can conditionally execute any expression in the context of that event. In many cases you can not only perform an action but also stop the event from completing. For instance, you can check new reservations for meeting certain criteria like minimum stays on holiday weekends, and not allow it to be saved unless it meets this criteria.

Most reservation status changes are trappable events, as well as some customer and transaction changes and dialogs. There are also some general actions like operator log-in and log-out, program start and stop, and timer events to allow an action to be performed every second, minute, hour or day.

As with all advanced customizations, this requires a rather technical understanding of the system. **However it must also be emphasized that Event Actions are much more "dangerous" than any other customizations because they define actions that happen automatically, potentially changing the overall operation of the program, and also potentially causing a serious system malfunction.**

Event Actions Setup

To create an Event Action, go to Maintenance / Advanced Customizations / Event Actions. This opens the Event Actions Setup dialog, which lists all current Event Actions and has the typical functions for Adding, Inserting, Editing, etc.

You can also Export one or more Event Actions to a text file, or Import Event Actions. This is primarily for you to import Actions created by the software provider, though it can also be used to transfer Actions between multiple databases.

Event Actions cannot have duplicate names. If you make a Copy of an Action, text like "(copy 1)" will be added to the name to make sure it's unique. Of course you can change this to be more appropriate. Duplicate checking for the names is not case-sensitive ("My Action" is considered the same as "my action").

Rearranging Event Actions

The order in which the Event Actions appear here in Event Actions Setup will determine the order in which they're processed, in particular if there's more than one Action defined for the same Event Trigger. While this is not likely to matter in most cases, if more than one Action is triggered by the same Event, then the results of one could affect other. If you want to move them around, use the Move Up and Move Down buttons.

Editing Event Actions

The Edit Event Action dialog is shown when adding or editing an Action from Event Actions Setup.

Action Name

The name should be descriptive enough for selecting the Action from the Setup list -- the name is not used anywhere else. Each Action must have a unique name (which is not case-sensitive).

Enabled

The Action can be disabled so that it does not get triggered regardless of the conditions. Technically you could also delete the Action, but if you might want to use it later or keep it for reference then it's better to just disable it. This is also handy for disabling Actions you haven't finished or tested sufficiently.

Note that Event Actions don't have an access level setting (presumably most actions should happen no matter who is logged in) -- if an action should depend on an access level, then include an expression to check the level of the current operator in the Condition (see below).

Event Trigger

Select the event from the list that you want to trigger your action. Note that most events have both a "before" and "after" option, so for instance you can do an action before and/or after the event is processed internally. As an example, you can have an action that does some validation before a reservation is checked in (optionally preventing the check-in with the Abort option below). You could also have an action that's triggered after the check-in is complete, such as printing a form (which would not get triggered if the check-in was aborted).

Note that there are some grey areas as far as exactly when the action will be triggered, which means the internal sequence is not strictly defined and could change in future versions. For instance an after-check-in action is guaranteed to be triggered after the "Checked In" status is changed for a reservation, but it whether it's triggered before or after the charges and payments are applied, a receipt is printed, and other synchronized reservations are updated is all grey area -- so try not to assume anything about related changes.

While there are events for viewing customer and reservation details and transactions, don't forget that the Dialog customizations can also allow expressions to be executed when entering or exiting these dialogs (after the dialog is opened and before it's closed, as opposed to before it's opened and after it's closed). The exact nature of what you need to do might make using one or the other of these customizations more appropriate.

Time Triggers

There are triggers for "Every Second", "Every Minute", "Every Hour" and "Every Day". They sound self-explanatory enough, but there are several caveats to these.

Generally these are triggered at the "change" of the minute, hour, and day (when the system first notices that it has changed, e.g. the "Every Hour" trigger will happen as soon as the hour digit changes on the clock).

However, timed events are suspended when any dialog is open so that the operator is not interrupted (and because the data could be in an inconsistent state while a dialog is open). Once all dialogs are closed, then event checking is resumed. For "Every Second" events, this generally means that all intervening triggers are lost (e.g. it won't try to catch up with possibly 100's of "missed" triggers). However it does check against the last time an event was actually triggered, so for instance if the Minute or Hour rolled over while a dialog was open, then that event will immediately be triggered as the change is noticed. Of course this also means that the event is not guaranteed to happen "exactly" at the roll-over time.

It can be difficult to get events to happen at regular intervals with any consistency. For instance if you want something done every 30 minutes, one method would be to define an "Every Minute" trigger, and use the Condition expression to check for the current time's Minutes being either 0 or 30. However, if a dialog is open for more than a minute, e.g. from 3:59 to 4:01, then the event completely misses the 4:00 check and the condition won't be met until 4:30 (assuming a dialog is not open then also...). One way around this is to create your own Setting that stores the last time your Condition expression was executed, and check for that being 30 minutes ago (or longer). Then you don't rely on the exact time the event is triggered, but it's still subject to how long a dialog is left open, so intervals would commonly vary from 30 minutes to perhaps 45 minutes or more, depending on how long an operator works on something.

Important Note: It may be tempting to do something like this Every Second to make sure it's checked as often as possible. However you don't want to execute a complex expression every second, since it could significantly lock up the system, so be conservative on how often something needs to be done. For instance, setting the value of a Setting can take significant time because it involves a database change (which means immediately saving the database to the hard disk, refreshing views, synchronizing other workstations, etc.), which could completely lock up the system. (In fact it would be more efficient to use a file to read & write the last-checked time, since it won't affect anything else and is much faster than writing the whole database.)

Condition

This expression is executed when the action is triggered, and the result determines whether the Action is executed. Naturally the result should be a boolean (True or False) value, or else leave the expression blank to always execute the Action.

To edit the condition expression, click on the text box or click the Edit button next to it. The Expression Creator dialog will be used to enter the expression.

Action

This is the expression to execute for the event (if the Condition is met, of course). If the event involves a particular record, e.g. a Reservation being checked in, then the appropriate context information will be available to the expression. The result of the expression is ignored and can be any type of value unless the Abort option is selected (below).

To edit the action expression, click on the text box or click the Edit button next to it. The Expression Creator dialog will be used to enter the expression.

Context

If the event involves a particular record, e.g. an event for a particular Reservation, then the appropriate context information will be available to the expression from the **ThisRecord()** function. If the event also involves a specific date, for instance the events for right-click functions on the Rack like Extend Reservation, then **ThisFromDate()** and **ThisFromPeriod()** context will also be available. There are also some special cases -- for instance in the Monthly billing, Meter reading, Select Rates and Auto-Rates "before" events, **ThisListCount()** and **ThisListRec()** can be used to get the transactions about to be added (allowing you to change the transaction details before they're added).

However there are also some exceptions to the general rules. For instance, the Edit Customer event may be triggered from Add Customer, in which case **ThisCust()** will not be valid -- it would only be valid if the event is triggered when a customer is already known, such as from a right-click "Customer Details" action. Also, for the Split Reservation event and possibly some other events triggered from right-click menus, the normally intuitive **ThisDate()** is not set -- instead, use **ThisFromDate()** (this is because some cases may involve both a From date and a To date).

Abort the Event....

If this option is selected, then the result of the Action expression is checked for a False (.F.) value (the result of the Action expression should be a boolean value, of course). If it's False, then any further processing for the event which triggered this action will be aborted. Obviously this is usually only useful for a "before" type of event trigger, since the "after" triggers only happen after all of the important stuff has already happened. However if you define more than one "after" action for the same event, then aborting will stop any following Actions from being processed.

This is generally used to check some special condition before continuing with an event like checking in, checking out, etc. You could even open a special dialog or prompt for the user (e.g. "Is the customer over 18 years old?"), and decide whether or not to continue based on the results.

Note: It's usually a good idea to include a **MessageBox()** function in the Action expression to show a message if you're going to abort further processing, so that the user knows that the event is going to be aborted (and why).

User-defined Tables

Overview

The ability to add fields to the existing pre-defined tables like Customers, Reservations, Sites, etc, is usually enough to meet the customization needs of a typical campground. However, we have added the ability add completely new tables to the database so its functionality can expand just like any general-purpose database system (Access, SQL, etc). The most common use of this will be to add your own Pick Lists, i.e. to add a field for which specific values can be selected rather than allowing the user to enter any text.

When you add a new Table, you will of course also be able to add whatever Fields you want to it, and also set up links to it from other tables (Relationships).

As with all advanced customizations, this requires a rather technical understanding of the system as well as database functions in general.

Tables Setup

To add or modify a user-defined Table, go to Maintenance / Advanced Customizations / User-defined Tables. This opens the Setup Tables dialog, which lists all current user-defined Tables and has the typical functions for Adding, Editing, etc. Note that while there are functions to Insert or Move Up and Move Down, a Table's position in the list does not affect the functionality in any way.

You can also Export one or more Table definitions to a text file, or Import Table definitions. This is primarily used for importing Table definitions created by the software provider, though it can also be used to transfer them between multiple databases. Note that the Field Definitions for the table are also Exported and Imported along with the basic table definition, but any user data in the actual tables is not exported or imported with these functions (that can be done elsewhere).

Tables cannot have duplicate Unique Names (Internal Names), since that is how the system will reference them. If you attempt to create a Table with an existing name, it will not allow it. Likewise, if you try to import a Table with an existing name, the import will fail. While it is allowed to have tables with duplicate Display Names, this is not recommended since of course it would be hard to tell which table you're using in certain functions, and could make it impossible to select one of them when building expressions.

In addition, there is a Unique ID field which cannot be duplicated. User-defined tables can be from 100 to 999. The ID is also used for internal reference (e.g. for Audit Trail entries).

Managing Tables

To Add a new Table, use [Add table definition](#) (or [Insert table definition](#)). That will open the Edit Table dialog so you can enter the table specifics, as well as manage Data Field Definitions.

Important: Once a Table is added or imported, the Names and ID (and whether it's a Pick List or not) cannot be changed. If a mistake is made, the only recourse is to [Delete](#) the table and create it again.

There is also a function here to [Edit Raw Data](#) of an existing table. You can use this to set up a user-defined Pick List (like standard Pick List editing) or manage any table's contents, just like the Raw Data Table functions for standard tables.

You can also [Delete](#) tables, but of course if there is any data in the table, that will be deleted as well. Any other functions that reference the table would also cease to function. You could, however, add a new Table definition with the same Unique Name, Unique ID, etc, essentially starting it from scratch again. Since the tables themselves are never referenced by their "Record ID", adding a table back in with the same information would restore the functionality including any linkages to it.

Referencing Tables

A Table by itself isn't very useful. You'll probably want to refer to it from some other table, or at least be able to list the records in it, add new records, etc without having to use the Raw Data Tables.

You can add functions (e.g. to the Menus) for adding records to the table, viewing the records and editing them, etc. See below for more details.

In addition, there are maintenance-type functions to view & edit the raw table (using **ShowRawData**) and modify the data fields (using **ShowDataFields**), so you can add those to the Menus as well.

One primary use of a custom table would be as a new Pick List to use in a table like Reservations. This requires a Relationship to be set up so that it can be used like other Pick Lists. See the User-defined Relationships section for details.

Another reason for creating a table would be so that you can link a number of items with specific details to another table -- for instance you could have a "Children" table with details of each child, and a Customer could have a list of Children (links to multiple records in the "Children" table). Again, that requires a Relationship setup.

Of course all other customization functions can reference your user-defined table just like any other table, e.g. Queries, Forms, Dialogs, Menus, etc., so the functionality is virtually unlimited.

Dialogs for Editing, Browsing, and Listing User-defined Tables

Once you have created a custom table (other than a Pick List), you'll want to be able to easily view and manage the records in it, like Campground Master has with functions such as Site Setup to list the Sites, and Site Details to edit the fields of a Site. Some standard functions and templates have been set up so that you don't have to create all of those functions from scratch.

First you need a way to Edit a record of your custom Table. To get a dialog for editing a record, complete with the typical browsing functions at the top like Site Details has (Next/Previous, Add, Delete, Print, etc.), you have to create a Dialog Definition for an Edit generic Record dialog. See the "The Edit Record Dialog" section later for more details.

Once you've created that dialog, there are a few ways to access it:

- **AddEditRecord** and **EditRecord** functions -- use these in a Menu definition or anywhere needed to add a new record and edit it, or edit a known record. More details are in the "The Edit Record Dialog" section.
- **ShowRecordList** function -- use this in a Menu definition to show a typical record-list function (like Sites Setup). It will use your Edit Generic Record add-on dialog when the Add/Edit functions are used. More details are in the "Record List Dialog" section.

Editing Tables

The Edit Table Definition dialog is shown when Adding or Editing a Table from Tables Setup.

When adding a new table, you will enter the identifying information for it, select whether it's a Pick List or some other table, and start adding Data Fields to it. If you're Editing an existing table, the only things you can change are the Unique Identifier Field, Notes, and Data Field Definitions.

Displayed Name -- This would be the user-friendly name for the table, used when editing records of the table, etc. This would typically be something like "Membership Type", using capitalization and spaces between words in order to be consistent with the rest of the system.

Internal Name -- This is the name used within the system (and whenever using Advanced Customization functions for the table), so it must be unique. We also don't recommend using spaces in it. So for instance it may be something like "MemberType" to be consistent with other tables in the system, or even just "MT" to make it easier to use in expressions.

Short Name -- This is a unique 4-letter abbreviation for the table (e.g. "Memb"). While this is not currently used for the user-defined tables, there may be functionality added later that uses it for expressions, etc.

Pick List? -- Check this box if the table is to be used as a Pick List, rather than a general-purpose table. There are some differences in the way Pick Lists are handled, for instance when adding them to a dialog for user selection (see below). Also, when a Pick List is created, all of the standard fields required for Pick Lists are automatically added.

ID -- This is a unique ID number for the table. It must be a 3-digit number not used for any other table. It's primarily used to identify the record type in things like the Audit Trail.

Unique Identifier Field -- Once you have fields defined, you can select a field here to be a unique identifying field for each record. For instance if it's a Pick List, this should be "Selection Name". It means that this field must be different for every record in the table, and that this field can be used to uniquely identify the record. Note that this is not the same as an "index" in database terms. The Record ID is always used as the record index for instance when linking to the record from another table (see Relationships). The Unique Identifier should be a user-friendly text field. Note that this field is also used if Importing records of this type to see if it should enforce unique record "names".

Data Field Definitions -- This button opens the typical Data Field Definitions dialog where you can add and edit the fields of your new table. Note that if you're adding a new table, clicking this button will immediately "create" the table and make it a real system table, so no further editing of the name, ID, etc is possible.

Edit Raw Data -- You can use this to enter (or edit) data in the table, for example to set up a user-defined Pick List (like standard Pick List editing) or manage any table's contents, just like the Raw Data Table functions for standard tables. Note that if you're adding a new table, clicking this button will immediately "create" the table and make it a real system table, so no further editing of the name, ID, etc is possible.

Print -- This will simply print the fields shown on this dialog, for reference.

Special Handling of Pick Lists

In most respects a Pick List is the same as any other table, but is generally only used to present a fixed list of values/options for a particular data field, e.g. the Site Type of a Site, or the Category of a Transaction. This makes it easy to use and eliminates errors (the user doesn't have to type it every time), saves space in the database (only the item's record ID is stored, not the whole text), and makes it simpler to do filtering and reporting based on the pick list options.

When you have a Pick List table and its associated Relationship set up, you would refer to it by adding a field with the type "Pick List item (Enum)" to some other table, e.g. Customers. This allows the system to automatically know how to handle this kind of field, relationship, and table combination. One particular place this happens is when adding the new pick-list field to a custom Dialog Definition. Using the Quick-Add Field function, it will automatically add all of the code necessary to create a drop-down selection list on the dialog with all of the enabled pick list items in it, so you can use it just like any other pick-list in the system. (If you use the generic "Link to Record" field to refer to it, then you will only get a read-only text control showing the current value, so the special Pick List functionality is lost.)

Also, a Pick List has a specific set of required fields, such as Selection Name, Report Heading, Enabled, etc, that the system uses for various functions. Those fields will be added to your new table automatically if it has the "Pick List?" option selected. You can add any further fields you want, but of course it would be up to your custom code to utilize any extra fields. For more details on Pick List fields and managing Pick Lists, see that section in the documentation.

In order to manage the items in the Pick List, use the Edit Raw Data (on Tables Setup), or you can create your own Menu selection to use the **ShowRawData** function.

The "Record List" Dialog

A generic "Record List" dialog template is defined that can be used with User-defined Tables.

To invoke this dialog, use the **ShowRecordList** expression function in a Menu definition. It will show a typical record-list function (like Sites Setup and similar dialogs) complete with functions to Add, Insert, Delete, Copy, Move Up/Down, Import and Export, and Print List. An "Edit Generic Record" add-on dialog should also be defined for the same User-defined Table, which will be used when the Add/Edit functions are used on this Record List dialog.

You also need to provide a list of field ID's to include in the list (each field will be a column in the list). The complete syntax of using this dialog is:

```
ShowRecordList(cTableName, cFieldList [, bAllowAdd [, bAllowDelete]]
```

Example using a user-defined "Children" table and showing the first and last names, allowing adding but not deleting:

```
ShowRecordList("Children", "User_Child_First,User_Child_Last,User_Child_Last", .T.,  
.F.)
```

The "Edit Record" Dialog

A generic "Edit Record" dialog template is defined that can be used with User-defined Tables (though it could technically be used to create a custom editing dialog for any record type).

To create an Editing dialog for your custom table, you must create a Dialog Definition as an "Add-on" to the dialog type "Edit Generic Record", with the Base Table set to your user-defined table name. It will have the typical browsing functions at the top like Site Details has (Next/Previous, Add, Delete, Print, etc.), which you

can optionally enable when invoking it. This uses a standard template so that the browsing controls are handled for you. By default the dialog is only large enough for the top browsing controls, so put in some number (try 500 to start) for the Height to make it taller). Then use Quick-Add fields to add all of the necessary fields from your table, using 80 as the starting top position. Adjust the size and field positions later as needed.

Once you've created that dialog, there are a few functions available to access it:

AddEditRecord

Use this in a Menu definition or from a button on another Dialog definition to add a new record of this type and open your custom Edit Record dialog to enter the data. The only argument is the table name, for instance:

```
AddEditRecord("Children")
```

It will return the record that was created (or NullRecord() if it was canceled).

EditRecord

Use this where needed to open your Edit dialog with a known record. For instance in a Query definition, set up a Double-click Action expression with **EditRecord(This())**. Or you can create a Menu definition using **EditRecord(TableRecAt("MyTable",1))** to browse starting at the first record in the table. You can also specify which functions are enabled on the dialog (all are enabled by default, if not otherwise specified). The full syntax is:

```
EditRecord(rRecord [, bBrowse [, bAllowAdd [, bAllowDelete]])
```

ShowRecordList

This will actually show the Record List dialog as explained in that section, but it will use your custom Edit Record dialog if the record is edited from that dialog, just as if EditRecord is called. More details are in the "Record List Dialog" section.

User-defined Relationships

Overview

Anyone familiar with relational databases or setting up a database in Microsoft Access or SQL should be familiar with "Relationships". For all of the standard tables in Campground Master, the relationships are pre-defined -- e.g. the Customers-to-Reservations relationship, Customers-to-Transactions, Sites-to-Types, etc. However if you want to add your own Pick Lists or add completely new tables for special purposes (through User-defined Tables), you'll need to be able to define the relationships between them. This functionality enables such definitions.

As with all advanced customizations, this requires a rather technical understanding of the system as well as database functions in general. Since this is a very advanced topic, only the basic details of how to create them are given here. It's assumed that if you're manipulating tables and relationships then you understand relational databases and how relationships work.

Relationships Setup

To add or modify a Relationship, go to Maintenance / Advanced Customizations / User-defined Relationships. This opens the [Setup Relationships](#) dialog, which lists all current user-defined Relationships and has the typical functions for Adding, Editing, Importing/Exporting, etc. Note that while there are functions to Insert or Move Up and Move Down, a Relationship's position in the list does not affect the functionality in any way.

Note that the pre-defined relationships in Campground Master cannot be modified. This function only manages your custom-defined relationships. As such, at least one of the tables you're linking with them will likely be a custom table you've set up through User-defined Tables (there should be no reason to add a new relationship between the standard Campground Master tables).

You can also [Export](#) one or more Relationships to a text file, or [Import](#) Relationships. This is primarily used for importing new Table definitions along with their Relationships created by the software provider, though it can also be used to transfer them between multiple databases.

Adding a Relationship

Before you can add a new relationship, you need to already have tables with appropriate "from" and "to" fields ready to be selected. For instance, if setting up a custom Pick List (like the Membership Type mentioned in previous sections), add the new Table first (as a "Pick List"), and also add a linking field to the table that will be using it (eg. add a Membership Type "Pick List item" field to the Customers table through Data Field Definitions). Now you're ready to create the relationship -- click the [Add relationship](#) button (or [Insert](#) if needed in a particular order). That will open the Edit Relationship dialog to enter the details.

Editing a Relationship

A relationship can be changed any time if needed, but presumably only to fix something done incorrectly before and the relationship was not being used yet -- all kinds of bad things can happen if you arbitrarily modify a relationship that has already been in use. Simply select the one to edit, and click [Edit relationship](#).

Deleting a Relationship

Presumably this would only be done if you made a mistake or you're no longer using the field or table referred to by the relationship, or have never used them. While it will have no affect on the actual data stored, it would of course not show data the same way without the relationship and could cause system errors if the field is still displayed somewhere.

Editing Relationships

The [Edit Relationship](#) dialog is shown when adding or editing a relationship from Setup Relationships.

Here you define the From and To details, and optionally designate it as a "unique" relationship. Mechanically it's as simple as selecting the tables and fields from drop-down lists. However it's important that you understand what to select and hopefully why (as well as how relationships work in databases, which is beyond the scope of this document).

[From Table](#) -- Select the table in which the "link" field is located that will refer to the related table. In the example of a Membership Type pick list for customers, this would be the "Customers" table.

From Field -- After selecting the "From Table" (so this list is filled with the appropriate fields), select the "link" field. In the Membership Type example, this would be the User field you added to customers for membership type, with the type "Pick List item (Enum)". The field selected here must be one of 3 types:

- Pick List item (Enum) - specifically for use with Pick Lists, but technically could be used for any relationship where you would normally want to have the user select one record from the related table, and multiple records could refer to the same record in the related table. This is usually a many-to-one relationship.
- Link to Record - a general link to a single record in the related table. For instance, the Reservation record has a single link to a Customer record. This is often a one-to-one relationship but can be a many-to-one back-link in a one-to-many relationship (as in the case of Reservation-to-Customer).
- Linked List of Records -- a general link to any number of records in the related table. For instance, the Customer record has a linked list to many Reservation records. Naturally this is a one-to-many relationship.

To Table -- Select the table being referred to by the link in the "From Table". In the Membership Type example, this would be the Membership Type table (pick-list).

Note: there is no "To Field" selection, because the To Field is always the Record ID. Every table has a Record ID as its index field.

Display Field -- After selecting the "To Table" (so this list is filled with the appropriate fields), select the field in the "To Table" that will be shown as the text for the linked record, e.g. when displaying the From Field. In the Membership Type example, or for any Pick List type table, this would be Selection Name. So for instance in a Query or a Form definition or anywhere you use the expression function **FieldText()** for the "From Field", instead of just displaying the Record ID of the linked record it will show the text from the field you have selected here.

'To' record is only referenced by the 'From' record -- This should only be selected if the related record ("To" record) will only be linked from one and only one "From" record (i.e. a one-to-one or one-to-many relationship), and there's no reason to keep the "To" record if the "From" record referring to it is deleted. If this box is checked, it is considered a "unique relationship", which means several things are generally handled automatically by the system (see exceptions below):

- Whenever the "From" record is locked (e.g. for editing), the "To" record is also locked.
- If the "From" record is deleted, the "To" record is also deleted.
- If the "From" record is Exported, the linked "To" record is also Exported (and Imports along with it as well, as a new record).

Naturally this option should not be used for Pick Lists, since many records will refer to the same Pick List item. One typical application having this option selected would be a list of Children linked from a Customer. Presumably each child record only belongs to one customer (and thus only linked to that customer and no others), so if the Customer is deleted their linked children should be deleted along with them and not left in the system as orphans.

Exceptions to automatic functions -- The automatic locking or deleting of the linked record only occurs with "normal" user interface functions, such as through the standard Record List or Edit Record dialogs. It will not occur if using Raw Data Tables to manipulate the data, or if using functions like **DeleteRecord()** directly within a Script.

Import Package

This function, available through Maintenance / Advanced Customizations / Import Package, is primarily for you to import customizations created by the software provider. This difference between this function and the "Import" functions available on the various Setup dialogs (e.g. Setup Forms) is that this function will import every record in the selected file no matter what kind it is -- so it can import Forms, Dialogs, Menus, Color Schemes, etc in one step instead of going to each function separately.

13 Network Functions

Overview

This Network section only applies if you have purchased a license for networking more than one workstation. You can use the [View / Product Authorizations](#) function to see how many workstations your license authorizes you to network. If the number is 1, then you are not authorized for networking.

Network setup parameters and options can be found under [Maintenance / Network Functions / Network Setup](#), while some diagnostic and administrative functions can be found under [Maintenance / Network Functions](#). These are explained in more detail below.

Networking allows Campground Master to run on 2 or more connected computers (workstations). While you can install and run Campground Master on a network (or even on more than one computer) without a networking license, you cannot access the same database at the same time without losing data. The networking functionality is required for the different workstations to communicate their changes to each other and stay synchronized.

Note that the sample database ("demo") is not authorized for networking, thus it is safe to load at any workstation and will not affect others. If you are evaluating the software or want to try the networking before purchasing the upgrade, you may request a free 30-day trial license enabled for networking.

Setting up for a Network

Setting up Campground Master for networking is very simple, as long as your network meets the requirements. Network setup parameters and options can be found in the menu: [Maintenance / Network Functions / Network Setup](#).

EXTREMELY IMPORTANT!

DO NOT "SHARE" THE DATABASE FILE BETWEEN MULTIPLE INSTANCES OF THE SOFTWARE. THIS WILL RESULT IN A CORRUPTED DATABASE!

Campground Master uses TCP/IP communications to synchronize all data between computers in real time, rather than sharing the database file itself.

Because most computer administrators expect networking to be accomplished through a shared database file, it may take some effort to get past this assumption. Do **not** attempt to network multiple computers by loading the database through a mapped or shared drive, or in any way open or save the database through file sharing on the network. Please read through this entire networking section before attempting to set up networking for Campground Master. It's a very simple process, but must be done correctly.

Every computer running Campground Master must have its own copy of the database, on its own hard drive or other non-shared location. Never under any circumstances open a database file from more than one instance of Campground Master at the same time. If you're not sure how this will work, please read the section *How Networking Works*.

Here's a typical local network setup with the master and one laptop connected directly to a router and one laptop through WiFi (it doesn't matter to the setup whether it's wired or WiFi):

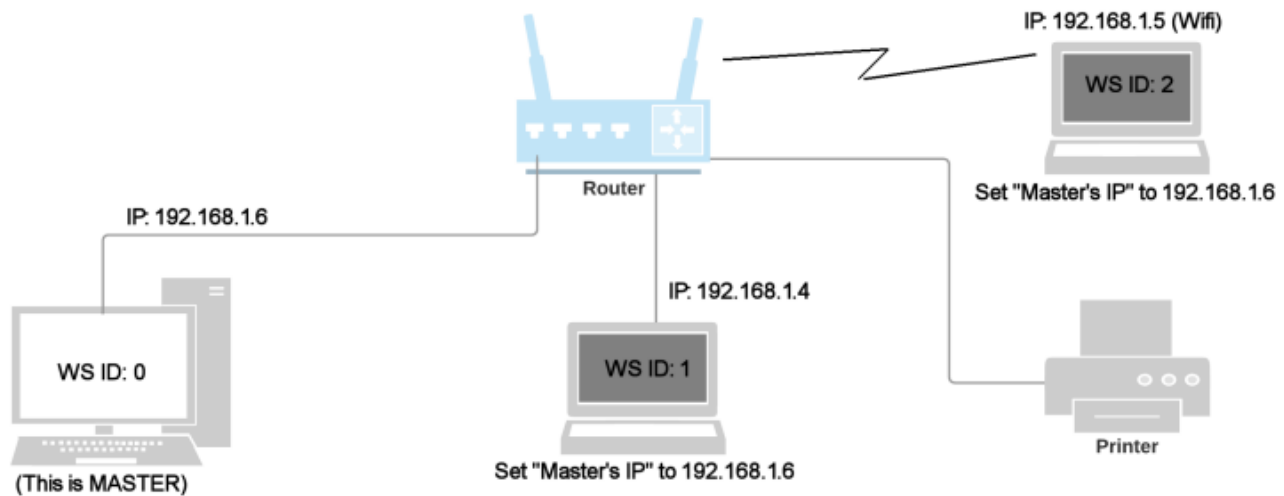

Quick Version of Network Setup (see below for more detailed steps)

These are useful for troubleshooting if it stops connecting, or when replacing or adding another computer.

This assumes that Campground Master is already set up (installed, database open, etc.) on the Master workstation (server).

1. Install the Campground Master software on each additional computer (workstation), and copy the database to each one.

Note: The computers do **NOT** all have to be running the same version of Windows. It makes no difference to the Campground Master networking.

2. On the Master workstation ("server"), go to Maintenance / Network Functions and select Show IP address for this workstation. Make a note of this number. (In the above diagram, it would have been 192.168.1.6)

Important: You do **NOT** need to use this "Show IP" function on any computer besides the master! All too often, people use this function on the client computers and worry that it shows a different number. Of course it does! It is normal, and in fact **required**, that each computer have a different IP address (just like your house has a different address than the one next door, so the mail goes to the right house), so don't use this function on the client computers and worry about them being different. That's normal! The **ONLY** function you should be using in the client computers is Network Setup, as explained in step 4.

3. On the Master workstation, go to Maintenance / Network Functions / Network Setup and note This workstation's ID (usually 0 for new installations) and the TCP/IP port number (usually 6010).
4. On each of the other workstations, go to Maintenance / Network Functions / Network Setup and change the Network Settings accordingly: The workstation ID should be different for each one (1, 2, 3, etc.), the Master IP address should be the address of the Master computer from step 2, and the Master's ID and port number should be as noted in step 3. Once you click OK (assuming changes were made), it should attempt connection.

Note: If you're attempting connection through the internet (not on the same local network as the master), see Networking through the Internet.

More Detailed Setup Information:

Networking Requirements:

- Every workstation or terminal must have its own place to save the database (e.g. its own hard drive) -- do not share the database file with other terminals.
- TCP/IP network -- the workstations must be connected via TCP/IP (which can also be through the Internet). We recommend using a switch (or router), rather than a hub, since a hub results in more load on the computers. Some installations have reported communications problems when using a simple hub.
- A known IP address for the master workstation -- The Master workstation must have a known IP address that can be accessed by the other workstations, so setting a static IP address on the local network is best. See the section following this one for more details. If you will be using the internet, you should also get a static IP address from your Internet provider (to avoid setup changes every time you connect).
- An unblocked port -- you can use any TCP/IP port number you wish, just make sure it's not blocked by any security software or routers in the system. We recommend a port in the 6000 to 12000 range, to minimize the potential conflicts with other software. The default is 6010.

Master workstation:

You don't need a separate computer for the Master. Any of the workstations can be used as the Master workstation. This workstation will automatically operate as a "server" for the Campground Master network, and all other workstations will operate as Clients. (Internally, they actually run different code depending on whether they are a server or a client.) However, it's not an actual "Server" in the traditional sense of networking. Also note that it should be turned on and running Campground Master all the time since it's the hub of communications, otherwise the other workstations cannot operate. The Master should have all power-saving and any sleep/hibernate/standby functions disabled as well.

Since the Master workstation will not have to request locks from other workstations and will operate "offline" automatically if the other workstations are disconnected, you may want the most-used workstation to be the Master. It should also be the fastest computer, since it has to do more work (routing all of the changes from each workstation to all other workstations).

Alternatively, you may decide that the master should be a "protected" computer separate from the reservation center, since it's the most important computer to keep running and should have the most reliable network connection. The decision will depend on your environment and whether speed is an issue. Since the master designation can be changed any time through the settings, you can always change it later.

Except for a few maintenance functions that can only be done on the master workstation, all workstations have equal abilities. Only the master workstation can perform the New database function and edit Field Definitions. Also, while any workstation can edit Raw Data Tables and Pick Lists, these should be done on the master workstation whenever possible due to the number of records that need to be locked.

Notes on using a real Server as the Master Workstation:

Because certain functions must be done at the Master workstation (the network master), and because Campground Master must be running as an application on the Master workstation, we don't recommend using a separate "server" computer as the Master. Campground Master cannot be run as a service, and someone should be able to access the Master at any time for maintenance and other functions. Also remember that each workstation has the entire database, so besides having automatic redundancy, backups can be done from any of the workstations. And of course it should not be a "cloud server", since Campground Master is not designed as a cloud system.

Setup Procedure:

1. Install the Campground Master software on each computer (workstation), and decide which one will be the master. Note that you will also need to get the database copied to each computer before they can be configured for networking (see step 5), but don't do that until the authorization code is entered (step 3).
2. If you're not familiar with configuring program and/or port exceptions in firewall software and routers, **temporarily** disable all firewalls and other security software on each computer (they can be re-enabled with proper "exception" configurations once you get the network operational). Some typical programs that can block TCP/IP networking are Windows XP's firewall or Security Center, Norton's Antivirus with Internet Worm Protection, McAfee's Antivirus, ZoneAlarm, and various other antivirus software, spyware blockers, pop-up blockers, etc. If you're using a switch or router that has firewall/gateway/blocking capability, either disable it or make sure that the TCP/IP port you'll be using (see step 7) is not blocked.
3. After you have a database set up and authorization code entered on the master, make sure the database is authorized for networking. This can be checked through the View / View Product Authorizations function -- the "Max Workstations" value will be greater than 1 if you are authorized for networking.
4. To make sure that the printer options, tab view options and other settings will be the same on each workstation (especially if you have already been using the program on a single computer for awhile), synchronize the settings for all workstations. This can be done at any time, but doing it before you copy the database to the other workstations will ensure they are set up correctly to begin with. Note that this is essentially a database function and does not require the other workstations to be connected yet -- it simply copies the master's settings to the other workstation's settings in the database. This function is under Maintenance / Network Functions / Synchronize local options to other workstations.
5. Copy the database to each workstation. A step-by-step guide to copying the database to another computer can be found in the Maintenance chapter. Do NOT set up Campground Master to open the database file through a mapped drive on the network! If more than one workstation is accessing the same database file, the data will become corrupt. **Each workstation should be loading and saving the database from its local hard drive.** It's also important that the database have the same name on every workstation. Note: If you get an error when connecting that the names don't match, use the File / Rename Database command to change the name. Afterwards you might also need to go to Maintenance / Program Options / Database to change the auto-open database to the current one.
6. Find the IP address(es) of the master workstation (configure it for a static IP address if possible -- this is done in the Windows system, not in Campground Master). If you don't know its IP address, you can use the Show IP address(es) function under Maintenance / Network Functions. If it shows more than one address, you will need to figure out which one is for the local network and will be visible to the other workstations. Local network IP addresses often start with 192 or 169. The **IPCONFIG** command from a Command Prompt (DOS window) can also indicate the local area network's IP address.

Important: You do **NOT** need to use this "Show IP" function on any computer besides the master! All too often, people use this function on the client computers and worry that it shows a different number. Of course it does! It is normal, and in fact **required**, that each computer have a different IP address (just like your house has a different address than the one next door, so the mail goes to the right house), so don't use this function on the client computers and worry about them being different. That's normal! The **ONLY** function you should be using in the client computers is Network Setup, as explained in step 9.
7. Decide on a TCP/IP port number. You can use the arbitrary default port (6010), or if that is known to conflict with other software you can change it.

8. On the master workstation, open the database and make sure the Network Settings (Maintenance / Network Functions / Network Setup) are set accordingly: This workstation ID should be 0, and the Master ID should be 0. (The master ID can be another number, but this is the easiest way to keep track of it -- just make sure that the "This" ID and the "Master" ID are the same, that's what tells it to be the master.) The other options are covered later, but all of the check boxes should be checked. Note that you must be logged into Campground Master as an Administrator to get into this function.
9. On each of the other workstations, open the database (if not already open) and go to Maintenance / Network Functions / Network Setup to change the client's Network Settings accordingly: The workstation ID should be different for each one (1, 2, 3, etc.), the Master ID should be 0 (assuming that's the Master's ID set in step 8 above), and the Master IP address should be the address of the Master from step 6. You do **not** normally need to use "Show IP address for this workstation" on a client, but if you do then be aware that it is **normal** for the last number of the IP address to be different on each computer (just like each person will always have a different phone number).

You can also specify various heartbeat frequency, timeout, and other options if you prefer. See the *Network Setup Dialog* section for more details.

If the master workstation is running at the time you perform the last step for each workstation, you should see it immediately connect after you change the settings and click OK. You're done!

If a connection error is shown, double-check your network settings and refer to the following sections, or contact us for support. If you are running a firewall, try disabling the firewall -- if connection is successful with the firewall disabled, you will need to determine how to enable the selected port for the firewall (consult the documentation for the firewall). Likewise, other security software may need to be disabled or configured to allow Campground Master to communication, such as Norton Internet Security, ZoneAlarm, McAfee, the Windows Firewall, or various antivirus or anti-spyware software. Some firewall configuration examples are given later.

IMPORTANT: Once every workstation is connected, start re-enabling any security software that was disabled previously -- enable one program at a time, and double-check to make sure it doesn't interfere with networking by closing down both the Master and Client workstation(s) and restarting them. If it prevents connection, see if you can configure exceptions in the security software to enable the Campground Master software and/or the IP port you're using (see step 7 above). **Under no circumstances should you leave your computer unprotected by keeping the firewall completely disabled.**

Network Troubleshooting Tips

Here are some basic troubleshooting steps you can perform any time you get an error message when attempting to connect. These do assume that the basic Networking Setup has been done, or at least getting to the point that it is attempting to connect. Note that you must be logged in as an Administrator to perform these functions.

Any of the 5 error messages below are usually self-explanatory and only require minor changes to fix, since they indicate that it is getting a response from the master but something else is wrong:

- **Mis-matched software version** -- means you need to install the same version on each computer.
- **Mis-matched database name** -- means you need to use File / Rename Database on either computer so the database names match.
- **Date format mis-match** -- means the Region settings in Windows for the location / date format on the computers don't match (e.g. US vs Canada).
- **Incorrect network password** -- means the passwords don't match under Network Setup, so enter new ones.
- **Date or time too different for proper synchronization** -- means the Time & Date settings on the client do not match up to the master, or are too different (according to the setting in Network Setup on the master).

However, if you get a connection error message like "**Verify that the IP and port settings are correct**", that means it can't get a response from the master. Of course the Master computer should be on, and Campground Master should be running, so that's the first thing to check. It wouldn't hurt to close Campground Master and restart it to make sure it's not locked up. Then you need to check the IP addresses.

If you don't know which computer is the master, then go to [Maintenance / Network Functions](#) and select [Network Setup](#). If it shows an IP address (numbers) next to "Master's IP address", then it's a client. The Master computer will show "(This is Master)" instead of an address.

Assuming a local connection, not through the internet:

Checking the IP addresses and connection

The first step is to re-check the IP addresses (since this can change due to power outages, etc):

1. On the Master workstation ("server"), go to [Maintenance / Network Functions](#) and select [Show IP address for this workstation](#). Make a note of this number.
2. On each of the other workstations (clients), go to [Maintenance / Network Functions](#) and select [Network Setup](#). Make sure the "Master's IP address" is set to the address from the master as seen in the above step. Especially pay attention to the last number. If it's different, correct the address and click OK to see if that fixes it.

Note that if that solves the issue, and if you have to do this often to correct the problem (i.e. the Master's IP keeps changing), then you should have your IT person set a Static IP on the master so it doesn't keep changing. See the next section, Setting a Static IP in Windows, for details.

Checking the Port

If the IP address is set correctly and it still doesn't connect, you should also verify the Port setting. While this is usually not a problem since it should never change, it's an easy check. On each of the computers, including the Master, go to [Maintenance / Network Functions](#) and select [Network Setup](#). Make sure they all show the same number for "TCP/IP port". This should be a number above 6000 (usually 6010, which is the default Campground Master uses, but in some cases there is a need to set it to a different number). It should never be a number less than 6000, which is likely to conflict with other commonly used ports. Regardless of the number, the important thing is that they are all set to the same number.

Checking that it can Ping the Master

If the IP address and Port are both set correctly and it still gets the same error connecting, then on each client use the Ping command from Network Setup (under [Maintenance / Network Functions](#), click "Test (Ping IP)" and follow instructions). This will make sure the master's IP address is reachable from the other computer.

If a Ping is successful, it just means that a computer is at that IP address -- it doesn't mean that it's the right computer, and it doesn't mean that there isn't a firewall that might Campground Master. Double-check the IP address (of the Master computer, not the client!) using the steps above. If that all looks correct, a firewall is probably blocking Campground Master on either computer. If you're not familiar with firewalls and the Firewall Configuration information in this documentation doesn't help, you'll need to contact a professional.

If a Ping fails, then you may have the wrong Master's IP address entered, or some other hardware or Windows issue exists with the network. If the settings are correct, it may be time to get a networking expert involved. However, you should also try completely rebooting the Master computer (perform a Windows "Shut Down" so

it does a full power-down) and then start again with checking the IP address (the reboot could "fix" the IP address, causing it to change).

If connecting through the Internet (the computers aren't on the same local network):

This is more complicated, since the Master's IP address is just the Internet connection IP, not the Master computer itself. (If you have the Master's IP address setting starting with 192 or 169, that's definitely wrong.) The Ping would only indicate that the modem or router is reachable, not the Master computer, and Ping may show failure even if the setting is correct. First make sure you've reviewed the Networking through the Internet information, to make sure you're using the correct IP address and have Port Forwarding set up. If you've gotten this far and either don't understand what we're talking about or it still doesn't work, it may be time to get a networking expert involved.

Setting a Static IP in Windows

The IP address of the master computer will keep changing (due to router power outages, for instance) if you don't configure the master workstation (server) to use a "static IP address". You have to reconfigure all of the client workstations to the new IP address whenever it changes. So we recommend configuring a static IP on the master computer (the other computers don't need a static IP).

Since this is a function of Windows, and of the details change slightly with every version, we can't provide a detailed walk-through. Ultimately we recommend having a computer professional set it up for you, but if you're willing to dig through some technical jargon then you can probably find the information yourself.. We've used Google to search for tutorials on the web, and came up with a few examples. We can't guarantee the links still work or whether they apply to your particular setup, so you might want to also try your router's documentation and/or your own Google search for "setting up a static IP in Windows".

Information for Belkin routers, but appears to be generic Windows instructions. Covers all versions of Windows up to XP (and may be fine for later versions):

<http://www.belkin.com/us/support-article?articleNum=157348>

Another example, from Netgear, for later versions of Windows:

<https://kb.netgear.com/27476/How-to-set-a-static-IP-address-in-Windows>

IMPORTANT: Making mistakes in configuration can disable networking entirely, so if you're not the "experimenting" kind, then we suggest calling a computer technician to do it for you.

Networking through the Internet

Campground Master can be networked through the Internet because it only needs a TCP/IP connection to the master computer. There is no need to have file sharing enabled, and no need for a VPN or WAN network setup.

Here is a typical setup of a network with an additional laptop accessing Campground Master through the internet.

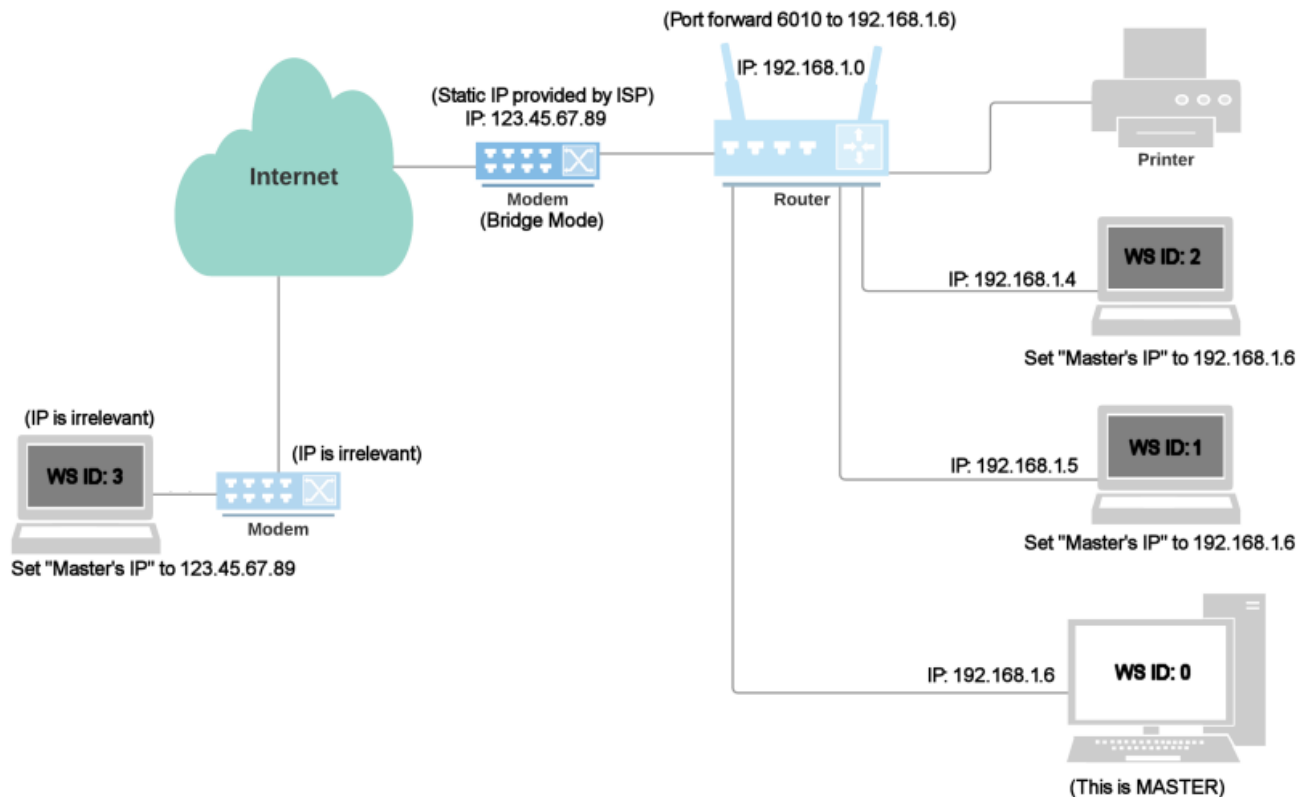

The basics of setting up a remote/internet client computer are the same as for a locally networked computer -- install Campground Master, copy the database to it, and configure the Network Settings as needed. However there are a few differences you need to know about:

1. The Master's IP address will be different -- on a local network it's usually a number starting with 192 or 169. However when connecting through the Internet, you need to use the IP address as seen through the Internet -- typically this is actually the modem's IP address, which can be shared by any other Internet-connected computers in the office (more on that below). The easiest way to get this address is to open a web browser on the network master and go to <http://WhatIsMyIP.com>. In the diagram above, this is shown as 123.45.67.89. (Of course your own internet connection IP address is different, don't just use this IP address.)
2. Because the client needs to know the master computer's Internet IP address, it's a good idea to arrange to have a "Static IP" from your Internet Service Provider (ISP, such as your DSL or cable network provider). Otherwise you may find that your IP address changes daily or any time the connection is broken.
3. If you're using a router, e.g. if your computer is not connected directly to the modem or if the modem has a router built in, then the router needs to be configured for "port forwarding". Think of the Internet IP as the main phone number of a large company and the local IP as the extension of the office you need to reach -- you router acts like the switchboard operator or PBX system, forwarding the outside call to the appropriate local computer's extension. In the diagram above, since the master's IP is 192.168.1.6, that's the address you would forward port 6010 to. (Of course your master's IP is probably different, don't just use this IP address.)

First you need to make sure that any router firewall settings have an exception for the IP port being used (6010 by default). Secondly, you need to set up port forwarding in the router to route that port to the master computer (more specifically, to the master computer's local IP address). You will need to set the protocol option to TCP (or TCP/UDP), for the single port. If there is an option for connection type (e.g. DSL vs Ethernet), that probably needs to be set to Ethernet. Refer to your router's documentation or call the manufacturer if you need assistance with router configuration. Also, this web site is an excellent guide:

<http://portforward.com/>

This web site has step by step configuration information for nearly all router models, detailed specifically for Campground Master -- just select your router/modem model from the long list on the main page (or click on "Router List"), then select Campground Master from the list of programs. You'll just need to know the master's local IP address (usually a 192.168... number from Maintenance / Network Functions / Show IP address). Note that the web site also sells a program that will supposedly do it for you automatically -- we have not tested that program so we don't know if it will work correctly.

Note: It's also important to set up the Master with a static IP address in Windows, so its local IP address doesn't change. Otherwise, if the router loses power or something else changes the master's local IP address, then the Port Forwarding will have to be changed again before you can access it remotely.

Also note that if there is a modem with routing capabilities between the master-connected router and the internet, you may need to set that for "Bridge Mode", so that it doesn't try to do additional routing. Otherwise you may need to configure that router for port forwarding also, making a hop between the routers. It can get very complicated with multiple routers involved.

Another handy tool is this open-port tester:

<http://www.yougetsignal.com/tools/open-ports/>

Enter your internet IP address and the port (e.g. 6010), and make sure the master (server) is running, and that should show "Open" if your port forwarding is set up correctly. If it shows "closed", there may still be issues with the setup. However it will sometimes still show "closed" even though port forwarding is correct and the connection will work. So it's a good indication of success if it shows "open", but does not necessarily mean there's a problem if it shows "closed".

Ping test note -- The Ping test may or may not work for remote connections even if you have the IP address correct (routers can have ping-response disabled), but if it does succeed then that's only an indication that you're reaching the router. It doesn't mean that port forwarding is working correctly.

Those are the primary issues with networking through the internet. On rare occasions there may be problems with an ISP blocking certain ports or causing further routing issues, but the 3 things listed above are usually the only issues different than local networking.

If you have a laptop that you take on the road but also want to connect locally when in the office, that can be easily done by changing the Master's IP address in the Network Settings back and forth as needed, between the local IP address to the Internet IP address.

Note: While networking is possible through a dial-up or other slow connection, you may experience problems if you're not connected on a regular basis. The synchronization process when connecting can result in the transfer of large amounts of data if you have been disconnected for more than a day. Even satellite connections such as Direcway through as Hughes can be an issue due to the slow uplink speed.

Setting up Multiple Connections or Databases

Some of this information pertains to networking multiple parks/databases, but this also explains how to work with multiple databases on one computer even if networking is not used. This can be used to manage multiple parks from one location, or to simply handle different business entities in separate databases in order to keep reporting separate.

Networking multiple parks/databases:

If you want to access multiple databases from one computer, you will need to have a copy of each park's database available (at least an initial version of it, with the same filename), and of course the IP address, port, etc. for the connection to the master computer of each park. This can be either over a local network or through the internet (see the "Networking through the Internet" section for the technical details of making remote connections).

The network parameters are normally set in the Network Setup Dialog, and saved in the Campground Master INI file. However, these parameters need to be different for each park you want to connect to, and there's only one INI file. Rather than having to go into Network Setup every time you change databases, these can be changed automatically by setting up desktop shortcut icons in Windows with the network parameters and database name in the Target field. This is done through Windows:

1. Right-click on the Campground Master icon (on the Windows desktop), select Copy.
2. Right-click on an empty area of the desktop, select Paste.
3. Right-click on the new copy of the Campground Master icon, select Rename, and enter an appropriate name (e.g. the park or database it will be used for).
4. Right-click the icon again, select Properties, and on the Shortcut tab you'll have the Target field where you enter the command line parameters mentioned below and also add the database name.

The available "command line parameters" are listed below. Note that these should start after the quoted executable file (CampgroundMaster.exe), e.g. after **.exe**" at the end of the existing text. There must be a space before the slash (/) for each parameter.

/Workstation= This is equivalent to "This Workstation's ID" in the network setup.

/WorkstationName= This is equivalent to the "Nickname" setting.

/MasterIP= This is equivalent to the "Master IP address" setting.

/MasterID= This is equivalent to the "Master (server) workstation ID" setting.

/IPPort= This is equivalent to the "TCP/IP Port" setting.

If a setting will be the same for all connections, it does not need to be included. For instance if the "master" for all databases you're connecting to will be the same computer, then the IP address is always the same and need not be included in the parameters. The database name can appear after all of the other settings, and can contain a complete folder path if necessary. Below are a couple examples (excluding the CampgroundMaster.exe portion of the Target line):

```
/Workstation=1 /WorkstationName=remote /MasterID=0 /MasterIP=192.169.34.55 /IPPort=6010 Marina.prk
```

```
/Workstation=2 /MasterIP=66.123.45.67 /MasterID=1 D:\Data\Hilltop.prk
```

Important: Note that there must be a space before the slash (/) for each parameter.

Multiple Databases on One Computer

If you're using Campground Master for multiple businesses, with separate databases for each, you might want them all to reside on a central server (that would be the network "master"). While this isn't generally recommended (since each one would need to be connected to the server to work with the software), this is possible if your organization requires it.

There are a couple special steps required for this. You need to enable multiple instances of Campground Master to run on one computer (which is normally not allowed, to prevent problems sharing a database), and you need to set up multiple shortcuts with parameters such that each instance loads a specific database and communicates on a specific IP port (they need to use different ports because they would all be at the same IP address). See the section above for details on setting up the shortcut icons.

If the master workstation or server is unattended, you may want to do this as shortcuts in the Startup group so they all start up when the computer boots. You could also include log-in information in the parameters so it doesn't show the Log In window, but be sure to use a low-level login to prevent tampering (set up a Guest operator to use as the default login).

To enable multiple program instances:

In the file "Campground Master.ini", you need to put the following setting in the **[Main]** section:

```
AllowMultipleInstances=1
```

This file will be found either in "Public Documents\Campground Master" (in Windows Vista and later), or "Shared Documents\Campground Master" (in Windows XP), or in the C:\Windows\ folder (in older versions of Windows or in Campground Master versions prior to v4.2).

To set up multiple shortcuts:

Lets say you need to set up the server to run Campground Master with 3 different databases. Start by copying the normal Campground Master shortcut on your desktop (and give each one a different name). Then set up each shortcut to load a different database and use a different IP Port by changing the Target in the shortcut's Properties. For instance if the databases are named "Park One", "Park Two" and "Park Three", set up the shortcut targets like this:

```
"C:\Program Files (x86)\Campground Master\CampgroundMaster.exe" /IPPort=6010 Park One
```

```
"C:\Program Files (x86)\Campground Master\CampgroundMaster.exe" /IPPort=6011 Park Two
```

```
"C:\Program Files (x86)\Campground Master\CampgroundMaster.exe" /IPPort=6012 Park Three
```

(Note that quotes are not needed around the database names.)

If you have a default "guest" login setup, with operator and password both "guest", then add this to the target line (before the database name):

```
/Operator=guest /Password=guest
```

In addition, you could have it minimize each instance to the taskbar tray by adding this to the target:

```
/Hide=1
```

You could also include the Workstation, MasterIP, and MasterID parameters, but if these are the same for all three instances then it's not necessary (once it's set for one of them, those settings are saved in the INI file that's shared by all instances).

Of course, you also need to configure the Network Settings in the respective client workstations to connect to the appropriate port for its database.

Important: Note that there must be a space before the slash (/) for each parameter.

Changing the Master Computer

You may occasionally need to change which computer is being used as the Master -- for instance if the previous Master computer isn't working. This is easy to do, but it's also easy to cause problems if it's not done correctly. Follow these steps for a clean switch over.

1. At the computer you're going to use as the new Master, do a "Request full database refresh" under the Network functions, to make sure it's fully in sync. This is assuming of course that the old Master is still functioning. If not, just make sure that the new Master has what you consider a "good" database on it, e.g. restoring from a backup if necessary. Actually it's a good idea to do this on all workstations, just don't do them all at once (wait for one to finish and refresh the screen before moving to the next).
2. Make a note of the workstation ID of the one that will be the new Master (See "This workstation's ID" under Network Functions / Network Setup) This will be the new Master workstation ID. Also make a note of its IP address (Network Functions / Show IP address(es) for this workstation). You will need to enter these numbers into all of the other local workstations.
3. Now you're ready to make the switch, which should only be done when nobody else is using the system. This should only take a couple minutes, not counting any router configuration that might be needed for a remote connection. Starting with the new Master that you just looked at in step 2, go into Network Setup and change the "Master (server) workstation ID" to the ID # noted in step 2. Now that the "Master" ID is the same as "This" workstation's ID, that computer is a Master. At the moment, that means there are 2 computers operating as a Master (and thus they are operating independently -- that's why this needs to be done when nobody is using any of the computers).
4. Now in each of the other workstations (including the old Master, if or when it's functional), go into Network Setup, change the "Master (server) workstation ID" to that same number, and also enter the IP address of the new Master computer (also from step 2). They should immediately connect to the new Master when you click OK to save the changes.
5. If you're using X-Charge for credit card processing, or Hercules for online reservations, see the notes below.

Important Reminder -- At no time is the "This workstation's ID" number changed on any workstation. This should never be changed (except for when installing a new computer), because it can cause synchronization problems.

Remote computers -- Once all local workstations are reconfigured as above, any remote computers need to be reconfigured the same way as the local workstations (change the master workstation ID #). If the new Master is still in the same location (same internet IP) as the old one, then that setting won't change -- but you'll need to reconfigure the router to forward port 6010 to the new Master computer's IP address. However if you have changed the Master from being at one location to another location (on the internet), then of course the IP address will be different because its internet IP address is different. If you don't know the internet IP address of the new Master, you can get this through WhatIsMyIP.com (refer to the Networking through the Internet section). You'll also need to make sure the router(s) in the new Master's location are configured properly to port forward port 6010 to the new Master.

Reverting back to the old Master -- If the old master is now working and needs to become the new master again, you should first configure it as a client (as in step 4 above) and allow it to connect -- this way it will connect to the current master and get synchronized. Once it's synchronized, go through the same process as before to change the master.

Multiple databases/connections using desktop icons with network settings -- If you have icons set up with specific network settings for connecting to each database, as described here, then you will also need to update the Target of each shortcut accordingly (e.g. new Master's ID and IP address as needed).

X-Charge note -- If you're using X-Charge for credit card processing, then you will also need to contact X-Charge support about changing the master for their software. (The X-Charge settings should not need to change in Campground Master.)

Hercules note -- If you're using Hercules for online reservations, then you need to change the workstation ID that it polls from (it should always be the master for best functionality). Go into Maintenance / Online Reservations / Hercules / Hercules Setup, and change the "Workstation ID to poll from" to the Master's ID from step 2 above. After you change it, restart the old master (if it's still available) and make sure it recognizes the change in Hercules Setup, and then do a Hercules / Request Full Sync from the new master.

Network Setup Dialog

This function under Maintenance / Network Functions will only be available if you are authorized for networking (more than one workstation), and changes can be made only if you're logged in with an Administrator access level. Note that these options are stored in the file **Campground Master.ini**, so they must be set up separately for each workstation.

The descriptions here give basic information about the options -- for complete information on network functions and options, refer to the other **Network Functions** sections.

Connection

Maximum number of workstations authorized -- This value is determined by your authorization (the number of workstations for which you purchased a license. It is not editable.

This Workstation's ID -- Each workstation must have a unique numeric ID, which starts at 0. So for instance in a 5-workstation system, this number will be in the range 0 to 4. The workstation ID will be shown in the caption bar for easy reference.

Nickname -- You can give a workstation a nickname, which will show in the caption bar and is also used in diagnostic messages. This is optional, so you can leave this field blank. The nickname will also be shown in the caption bar.

Master (server) workstation ID -- One and only one workstation is designated as the master, and will be running the server side of the network. This is usually the workstation with the ID of "0", but may be changed if necessary. It's critical that this is the correct ID -- it must be the ID of the workstation at the given IP address!

Master IP address -- This is the IP address of the master workstation (server). This value is not used on the master itself, so it will be greyed out for the master, but all other workstations must have this set properly. While this is usually a numeric IPv4 address, it's possible to enter a URL in case you have a custom DNS setup (an advanced procedure that would be up to your network specialist).

Show IP address button -- Shown if this is the master (according to the ID's entered). You can use this button to show the IP address of this computer.

Test (Ping IP) button -- Shown if this is a client workstation. You can use this button to test the connection to the IP address entered for the master.

TCP/IP port -- This is the port number used for communicating. All workstations must use the same port number. A number above 6000 is recommended to reduce the change of conflicting with other communications software.

Password -- You should choose a suitable password to protect access to your data (especially if connected to the internet). A default will be used (which is different for every database), but it can be changed here. It must be at least 8 characters long. We recommend changing this password every 90 days or less, or whenever an employee leaves the company, to minimize risk of unauthorized access.

Max allowed client time diff -- This setting (for the master workstation only) specifies how many seconds the clocks can be different between the master and a client computer and still allow the client to connect. This is important for proper database synchronization between the computers. This is initially set for 120 seconds to minimize connection issues, however we recommend that you lower this as much as possible to improve synchronization. If the computers are all on a local network and have internet connection, this can usually be very low, like 5 seconds, since the computers will automatically synchronize their time from the internet. Note that different time zones are automatically accounted for, assuming the computer's time & date settings are configured correctly.

Show "Connecting" progress window -- When this is enabled, a window will automatically open any time the a workstation (excluding the master) is attempting to make connection with the server. This should be left on to server as an indication whenever the connection is lost. (The window will automatically close 5 seconds after a connection is made.) However if the network is unstable and workstations require reconnecting often, this window may be disabled to reduce the annoyance.

Timing

Time-out for requests (3 to 600 seconds) -- Enter the number of seconds to wait for a response from the server when communicating (requesting a record lock or sending changes). Typically this should be about 3 to 5 seconds, but for slow (internet) connections you may raise this. It may also need to be raised if you're running a large number of very active workstations.

Remote update refresh delay (0 to 600 seconds) -- This determines how long to wait before the program is considered "idle" and can refresh the screen when an update comes in from another workstation. It does not mean that the data update itself is delayed. The purpose of having a refresh delay is so that the screen doesn't refresh frequently when you're trying to look at something or click on a function. It also determines the minimum time to wait between updates while idle, avoiding network delays for instance if the refresh takes significant time and there is a lot of network activity that would otherwise cause constant refreshing. Any time the mouse is moved or clicked, the program is considered "active" and screen refreshes from other workstations will be delayed until activity stops for the indicated number of seconds. If you open and close a dialog or change tab views, the screen will refresh immediately, so an easy way to force an immediate refresh is to click on another tab view and then click back, or to press **F9** for the Search function and then **Esc** to close it.

"Heartbeat" frequency (3 to 600 seconds) -- This time determines how often an "alive" message is sent to the server (or to other workstations from the server). This must be at least 3 seconds to avoid networking bottlenecks. This frequency also determines how often a workstation will check to see if it has been disconnected and will attempt to reconnect automatically (if the auto-start function is enabled). If all workstations are idle, this also serves to keep communications happening on the network, and will affect how frequently the network status indicator changes on the status bar.

Min. Delay between saves (1 to 600 seconds) Typically a 10-second pause in network activity is recommended before the database is saved, to avoid undue delays when there is a lot of activity. This setting specifies the minimum time it will wait after a change is received from the network before saving the database to the hard drive. It will wait for there to be no further network changes or keyboard & mouse activity before saving the data. If this is larger than the normal Auto-save time set under Program Options, this value takes precedence (unless the auto-save delay in Program Options is set to 0). However if this is smaller than the Auto-save time set in Program Options, then the Auto-save time is used.

Max. delay between saves (0 to 600 seconds) -- In case the network activity never has a pause long enough to meet the minimum delay setting above, this setting will force it to save the data after the period specified (assuming a delayed save is pending), so it's at least saved occasionally.

Max. block size for sending large files (kbytes) -- This sets the size to use when splitting up large files, like when sending the full database. The default size is 128K. Using a larger size might be slightly faster in total time to send, but at a certain point (over 200K), it can start causing delays in responsiveness. It's more efficient for the networking if it can process small messages, so it can handle multiple workstations at once without delaying other workstations from getting a response.

Diagnostic Options

Networking Enabled -- Unchecking this option will completely disable all network functions.

Auto-start Networking on program startup (and reconnect if disconnected) -- This should be left enabled for normal operations, but may be disabled to avoid repeated connection attempts for workstations known to be disconnected from the network.

Force Autosave of the database -- The auto-save function under Database options should be enabled, but just in case it's disabled by accident, this function will make sure the database is still saved after every operation. While it's recommended that the database should always be auto-saved after every change, this can cause delays in very active network environments or for very large databases.

Log all network activity -- This option can be enabled to create detailed network activity logs for troubleshooting. These logs are generally small and can be created without any noticeable affect on the system. Like other logs, they are automatically deleted after 30 days (or whatever the auto-delete setting is under Database options).

Log record locks -- This is only for extreme troubleshooting, and should not be selected unless directed by support. This will generate much larger log files and slow down the system, but may be needed for certain troubleshooting issues.

Request a database update every time connected -- This can be a dangerous option, so be sure you understand it before using it! When this is enabled for a client, it will request the full database from the server every time it reconnects. This can be useful for seldom-connected workstations, since it may be quicker to get the whole database than to get all of the changes since last connected. However, this also means that any changes made on this client while offline will **not** be sent to the master and will be lost. So only use this option if you know that the client never is used offline to make changes.

Show an Alert when a network synchronization error is detected -- Normally you want to leave this enabled, since any synchronization problems need to be remedied promptly. If for some reason these Alerts are more of a nuisance than a help, then they can be disabled.

Auto-fix orphans when detected -- If any orphan-causing network sync errors are detected, will auto-fix any orphans (after waiting for 5 seconds of idle time). This action is generally "silent" but will be recorded in the audit trail and will be shown in the status bar as it's doing it, in case it takes awhile. This should help eliminate most Orphan problems, or at least make them get corrected quickly. If you suspect this is causing a problem for some reason you can disable it, but it's recommended that you leave it on.

Delete all old log files (except today) and **Delete ALL log files** -- These should only be done if directed by technical support, and only if you're sure that a verified working backup is available. These functions will delete all logs except the current day, and is typically only used to solve problems with network synchronization due to excessive log size (e.g. when a workstation has been offline for a long period of time). Without the log files, networking cannot automatically synchronize individual changes made on each workstation, so the server may need to send the entire database to each client.

Connecting Progress Dialog

Non-master workstations will display this dialog any time a connection to the master is being made or is terminated (either upon starting up, whenever the connection is lost, or if a connection is manually initiated through the network functions). If this becomes an annoyance rather than a benefit, it can be disabled through [Maintenance / Network Functions / Network Setup](#).

During normal start up, assuming the auto-start network option is enabled, this dialog will appear to show the progress. Once a connection is made, the dialog will close automatically after 5 seconds (you will see the countdown). You can also close it immediately by clicking the Close button. Note that this will **not** close the connection, just the dialog!

If a disconnect or network error is detected, for instance due to network errors or if the master workstation is shut down, the Connection dialog will automatically appear to show that it has been disconnected. If a connection is not in progress or already established, the "Connect to Server" button will be enabled. You can click this to attempt a connection any time. However if auto-start is enabled, it may automatically start reconnecting immediately, or after the "heartbeat" time. Once it's connected you can again wait for the 5 second timeout or close it at any time (even if it's not finished connecting -- it will continue even with the dialog closed).

If a connection cannot be made, the dialog will show an error after a few seconds. Again, you can either wait for the heartbeat to reconnect automatically, click Connect to reconnect immediately, or Close the dialog and let it work on its own.

If your workstation is disconnected and auto-start is not enabled, you can use the [Connect to Server](#) function under [Maintenance / Network Functions](#) to initiate a connection (which will also show Connecting dialog).

Troubleshooting

See "Setting up for a Network" for Quick Troubleshooting Tips and other details on network setup procedures.

Request a Full Database Refresh

This function is available only to operators with Administrator access, and is available through [Maintenance / Network Functions / Request a full database refresh](#). It can only be done on a client computer, since the Master doesn't need to be refreshed from itself.

This requests that the entire database be refreshed (copied) from the master. This might be needed if log files become corrupt preventing resynchronization, or if the workstation has been offline so long that logs no longer contain all of the changes needed. (Generally these are detected automatically and a full refresh will be done as needed -- however this function is provided in the menu just in case things don't seem to be synchronizing correctly.) Note that this can cause significant delays at the master as well as this workstation while the database is being transmitted, so use only when workstation activity is minimal.

Make sure you only do it on one client at a time. A dialog will appear showing the status of the request as it is working, e.g. "Received part 1 of 10" . It cannot be aborted once requested -- while you can close the dialog if you want to try to exit the program, nothing else should be done on the client while it is being requested & received. Typically it can take 10 to 30 seconds for each "part" (each part is about 1 Megabyte), and for large databases there may be 50 or more parts. If it seems to get stuck shows that it failed, you may need to restart the master and client and try again, or manually copy the database from the master.

Once it is finished, the database will be reloaded and it will reconnect to the server, and everything should be synchronized.

If you still experience problems, for instance if the master repeatedly tries to synchronize a workstation or simply gets continually locked up in a synchronization loop when a particular workstation is connected, a Full Network Resync may be needed.

Full Network Resynchronization

Sometimes just using Request a Full Database Refresh isn't sufficient -- sometimes log files get corrupted or there is some issue where a workstation can't figure out how to get in sync.

If you're on version 10.0 or later, there's a one-step option that should work. Otherwise, there's a quick manual version that may work, and then a last-resort full re-sync that may be required.

Important: All methods assume that the Master computer has the most correct / up-to-date information. If not, that must be corrected first by copying the database from the most up-to-date client to the master.

The One-step Option

As of version 10.0, you can initiate a full resync in one step -- on the Master (server), make sure you're logged in as an Administrator and go to Maintenance / Network Functions / [Initiate a Full Network Resynchronization](#). After a couple conformation prompts, it will start the process, which is similar to the Quick Version (deletes log files on each computer and sends a full database). This can be a lengthy process, and it's still recommended to start with the clients disconnected and then connect them one at a time. However it should still work even if some are still connected.

The Quick Manual Version

Note: We recommend that you use this quick version only if you're using version 9.1 or 9.2. Earlier versions do not have the enhancements needed for this to work most of the time. This is also best used if you can first identify which client is causing the problem.

1. Shut down the master (server).
2. If the client is locked up, restart it. Campground Master will fail when attempting to connect... continue (close the connection window) and log in as an Administrator.
3. Go to Maintenance / Network Functions / [Network Setup](#). Under the Diagnostic Options tab, click "[Delete ALL log files](#)", and confirm the prompt.
4. Close the client.
5. Restart the master (server). Log in as an Administrator.
6. Go to Maintenance / Network Functions / [Network Setup](#). Under the Diagnostic Options tab, click "[Delete ALL log files](#)", and confirm the prompt.
7. Restart the client. Once it connects, watch to see if it Requests a Full Database automatically. If it does not, then go to Maintenance / Network Functions / [Request a Full Database Refresh](#).

Assuming that was the only client with a synchronization problem, this will likely resolve the problem. If not, then proceed to the full version below.

The Full version (last resort)

1. Shut down ALL clients.

2. On the master (server):

Make sure all orphans are fixed -- Maintenance / Database Maintenance / Report and repair Transactions orphaned from Reservations, and click the "Fix" button. Repeat for the other 2 "Report and repair" functions.

Also go to View / Alerts, and if any are shown then highlight them all and select "Dismiss".

Go to Maintenance / Network Functions / Network Setup.

- Under Timing, make sure the "Max delay between saves" is at least 600.
- Under Diagnostic Options, uncheck the box "Show an alert...". Also make sure the top 3 boxes ARE checked (Enabled/Auto/Force). The "Request full database" box should NOT be checked.
- Click "Delete ALL log files" (under Diagnostic Options), and confirm the prompt.

3. Under Maintenance / Program Options / Database, make sure "Automatically save the database..." is checked, and that "History Logging Enabled" is checked.

4. Make a backup from the master (Maintenance / Back up database), e.g to a thumb drive or somewhere you can access it easily. IMPORTANT: Be sure to use a unique name for the backup file so there's no mistaking the correct file when you restore from it below, and pay attention to the "Save In" location to be sure it's going where you want it to go (e.g. the thumb drive).

5. Shut down the master so clients can't connect.

6. On each client:

Start Campground Master.

If any alerts come up, use the "Close/ignore" option to close them.

Go to Maintenance / Network Functions / Network Setup.

- Under Timing, make sure the "Max delay between saves" is at least 300.
- Under Diagnostic Options, uncheck the box "Show an alert...". Also make sure the top 3 boxes ARE checked (Enabled/Auto/Force). The "Request full database" box should NOT be checked.
- Click "Delete ALL log files" (under Diagnostic Options), and confirm the prompt.

Go to Maintenance / Restore from Backup, and restore from the backup you made above -- paying attention to the "Look In" location and the file name so you now that you're getting the correct file.

... Repeat for each client.

7. Once this is done on each client, restart the master.

That should guarantee they are in sync. Start the master, and they should all connect immediately without a problem.

You might want to open the Networking Diagnostics window for awhile to make sure things are going smoothly. Keep an eye out for any issues like re-sending things repeatedly, workstations disconnecting, sending a full database, etc...

Other Network Functions

There are several functions under Maintenance / Network Functions that can be used when diagnosing network problems or for maintenance. Most of these are only available for operators with Administrator access.

Network Setup... -- This opens the Network Setup Dialog for setting various network options.

Show IP address(es) for this workstation -- This is just a utility function for determining the IP address of the master workstation, and will show all known IP addresses for this computer. This may be a single address or multiple addresses, depending on your network setup (e.g. one address may be visible to the internet and another visible to the LAN).

Connect to Server -- For non-master workstations, this will initiate a connection if it's not already connected to the master. A Connecting Progress Dialog will be shown (if it's not disabled in Maintenance / Network Functions / Network Setup).

Disconnect from Server -- For non-master workstations, this will immediately disconnect from the master. If you have the auto-start option enabled, you will be given an option to disable this option so it will stay offline (until the next connection is made manually).

Work Offline -- If this is a non-master workstation, you must specifically select this function to enable offline changes. You must also first Disconnect from Server if not already disconnected. Once working offline, changes can be made at will. They will be logged, so that when you reconnect to the server, the changes will be transmitted to the server to synchronize the database.

However, working offline is **not completely safe!** Even though it will synchronize the changes, there are limits to what can be synchronized. For instance, since locks cannot be acquired for changes, it's possible that a change you make will conflict with a change made by another operator. The results of this are unpredictable -- either change may take precedence depending on internal circumstances, but usually the earlier change will be kept because by the time your change arrives, the value has been changed already. Previous values are compared as an integrity check, so if the value is different than your previous value, your change will be ignored. Obviously it's also possible that a record has already been deleted before your changes are received (though this is rare). In general, record additions are safe because each workstation uses unique record ID's, and changes to different customers or reservations will be safe. However, be sure to avoid making any changes (including adding transactions) to the same customer or reservation on different workstations.

Start Server (allow connections) -- if the server has not been started, use this function to start the server (master workstation only).

Stop Server (work offline) -- This function for master workstations is similar to the Work Offline function, but in this case it will stop the server completely so all workstations will be disconnected.

Clear all record locks -- This master workstation function will immediately clear all record locks for **all workstations**. This can be useful if a workstation becomes disconnected before releasing its locks (during editing), and a record it had locked needs to be edited by another workstation. However, you should make sure that all other workstations are in an idle state (no dialogs are open) when you do this, otherwise it could unlock records that really should still be locked. An alternative would be to stop the server before clearing locks. When you restart the server, all workstations will re-request locks for records currently being edited. Likewise, any time the software is closed, all locks are automatically removed.

View all record locks -- The master workstation function allows you to see if there are any records locked (by other workstations). Only the raw information is shown -- the record type, record ID, and which workstation has it locked. This is mainly for diagnostic purposes. You can double-click on a line to see raw field information (for instance to see the customer name on a locked customer record). Note that the list does not refresh automatically -- after the initial display, click "Refresh" to update it.

View Network Diagnostics Window -- This will open either the Net Client or Net Server diagnostics window (depending on whether this is the master workstation or not). Unlike most other dialogs in Campground Master, this diagnostics window can be left open while you work. Actually, the window always exists and is functioning (recording messages), it's just hidden unless you view it.

Synchronize local options to all workstations -- This is used to copy this workstation's "local" settings to all other workstations. This will copy this workstation's settings to all other workstations' settings in the database, and of course send the changes to each workstation. It can be done on the master even if the other workstations aren't connected -- the changes will be synchronized just like other database changes when the workstation is reconnected. Use this with care if there is any reason that other workstations might require different settings. The local settings include: Printer Options, all tab view options (from their Option buttons), tab view default site filters, and default settings for Reports (meter lists, occupancy report, etc.).

Initiate a Full Network Resynchronization -- This is a shortcut function that can be initiated from the master (server) workstation only to complete the "Full Network Resynchronization" process in a single step. It will delete all log files and then tell each client to delete their log files and request a full database. Once initiated, each client will be disconnected and will go through the normal "Join" process, at which time it will be commanded to delete the log files, request a full database and then reconnect. This can be a lengthy process, and it's still recommended to start with the clients disconnected and then connect them one at a time. However it should still work even if some are still connected.

Check Full Resync Status -- This will show the status of each client workstation, whether it has completed the full network resync process. Note that it does not know which clients are actually in use, so any licensed workstation ID's that have not connected will show "Not completed". If they ever do connect, they will be told to finish the net resync process.

Net Client Diagnostics Dialog

This dialog can be opened on non-master workstations to view the activity on the network and perform a couple diagnostic functions. This dialog may be left open while working in the program (though it will stay on top unless it's minimized), or closed/hidden at any time.

This function is available only to operators with Administrator access, and is available through [Maintenance / Network Functions](#) / [View Network Diagnostics Window](#).

Network settings are shown for reference -- to change them, you must use the [Maintenance / Network Functions / Network Setup](#) function.

The large window will show status messages, indicating messages received and sent by this workstation. It will not show activity from any other workstation. In general, this can be used to see if it's getting and sending "Alive" messages, see the results of record lock requests, changes sent and received, and error messages. Sequence numbers are shown where appropriate, for comparison to logs if needed.

If you want to see the Alive messages, you must check the "Include details" box. (Unchecking this will help minimize the messages shown and allow easier inspection of the messages.) Also, when details are included you will see the details of every change transmitted or received, in the same format as the log.

By default the message window will hold 100 lines. You can increase this if necessary, however this can dramatically affect the speed and possibly cause networking problems due to extra delays (up to about 1000 lines should be tolerable without problems). Note that the number of lines will still be saved even if the window is closed / hidden (so the messages are still there when it's opened again. However, once the program is closed it will revert to 100 lines to avoid adverse effects.

Net Server Diagnostics Dialog

This dialog can be opened on master workstations to view the activity on the network and perform a couple diagnostic functions. This dialog may be left open while working in the program (though it will stay on top unless it's minimized), or closed/hidden at any time.

This function is available only to operators with Administrator access, and is available through [Maintenance / Network Functions / View Network Diagnostics Window](#).

Most of the functions are the same as the Net Client Diagnostics Dialog, but the server has a few additional functions.

The server diagnostics will show each of the workstations connected (by nickname if they have nicknames set up). There is a button to forcefully disconnect one or all of them, e.g. if it seems "stuck". (Remember that they will automatically attempt to reconnect if they have the auto-start network option enabled.) To completely disconnect and not allow reconnection of any client, click the Stop button to stop the server.

If you see a Start button instead of Stop, that means the server is currently stopped. The server will not automatically restart (even if auto-start is enabled) if you stop it manually. To restart the server and wait for client connections, click the Start button.

How Networking Works

This section describes in detail how the real-time networking functionality in Campground Master works. It may be helpful to understand what's going on behind the scenes, to get a better idea of why some things work the way they do.

Real-time Networking

Each workstation will have its own copy of the database, both on the hard disk and in RAM memory. This allows each workstation to operate quickly and independently when viewing data, running reports, etc. This also allows workstations to be operated offline if necessary -- though not recommended in general, this allows operation even if the network is down, or for instance if you want to do some reports offline. Note that non-master workstations can only work offline if the [Work Offline](#) function is specifically selected (administrator access is required for this).

Unlike most networked database applications, Campground Master operates as a real-time system. When changes are made at one workstation (reservations added, dates changed, etc.), those changes will be immediately sent to all other workstations so that they will be up to date. If the changes affect the current tab view, the screen will be updated immediately to reflect the changes, just as if they were done at each workstation (subject to a refresh delay setting, which can be used to prevent numerous screen refreshes when the workstation is in use).

As mentioned in earlier sections, Campground Master does not depend on a shared database file for networking -- every computer must have its own copy of the database, preferably on its own hard drive. Networking is done entirely through TCP/IP communications, with simple notification messages. This is similar to the way "Chat" programs like ICQ, AOL Instant Messenger, or MSN Messenger program work. Therefore it can work just as well through the Internet as it does through a local area network.

Naturally it's important to keep changes synchronized and to prevent two workstations from making different changes to the same information at the same time. This is achieved through three mechanisms -- record locks, sequence numbers, and logs.

Record Locks

Before any changes can be made to a record in the database, it must be "locked" by the workstation. All locks are requested through the master workstation (which also acts as the network server). If a record is already locked by another workstation, then the lock request will be denied, and the operator at that workstation will be informed that it can't be edited. If the lock is granted, then editing proceeds normally. For the most part this is transparent to the operator as long as there is no conflicting locks, except for a small delay when requesting the lock (e.g. before the editing dialog is opened).

Once the editing is complete, the changes are sent to the master workstation for distribution to the other workstations, and the locks are released so other workstations can edit the record if needed. If a workstation gets disconnected or goes down while it has records locked, these locks will be "stuck" in the master workstation -- but they will be cleared automatically when the workstation comes back online, or they can be manually cleared at the master workstation by an administrator function.

Sequence Numbers

Whenever changes are made, they are tagged with a sequence number and logged, as well as sent to the master workstation. If changes are missed for any reason, the gap in sequence numbers will be detected. The master workstation will request any missed changes from a workstation and will make sure they are applied in the correct order. Likewise, the master makes sure that a workstation is up to date before allowing it to lock any record, so that data integrity is maintained. Sequence numbers are checked often (along with the "heartbeat"), so a change missed due to network problems (extremely rare, but possible) will be quickly detected and corrected.

The other benefit of logging changes with sequence numbers is that it can allow automatic synchronization after a workstation has been offline. For instance, if you could call in to your network via the internet from home, all changes since the last time your home workstation was connected will be synchronized automatically. Likewise, you could work offline (preferably after getting synchronized), then call in to the network -- all of your changes will be downloaded to the master and the database will be synchronized.

If a workstation cannot be synchronized for any reason, there is a fail-safe mechanism -- the entire database can be transferred from the master to a workstation. This will be done automatically if the master can't find all of the changes needed by a workstation (e.g. if the log file becomes corrupt due to a computer crash), or it can be done manually any time if the workstation doesn't seem to have the correct data. Note that this can only be done **from** the master workstation -- if a client workstation, rather than the master workstation, is determined to have the only "good" copy of the database, then it must be transferred manually to the master and then synchronized to the other clients.

Logs

Sequence numbers indicate when changes are missed, but in order for a workstation to "catch up" on missed changes, they must be logged so that they can be retrieved. Each workstation maintains log files of all changes, both for its own workstation and for all other workstations. Thus if changes are requested for a specific range of sequence numbers, it can read them from the log and send them to the requesting workstation. If the log entries for the requested sequence numbers can't be found, the only recourse is to refresh the entire database -- this will be done automatically when needed, but can cause a significant delay. Therefore make sure that history logging is enabled and that disk space doesn't run out.

A new log file will be started each day, and named according to the database name, date, and workstation ID. Log files are automatically deleted after a specified number of days to keep disk space to a minimum, but you should keep logs for at least 7 days if possible. Another reason to keep logs for a longer period is that they can serve as a complete audit trail. Every single change to the database is recorded, and every entry has the date, time, and operator responsible for the change. The logs are in tab-delimited text format, so they can be examined if necessary (some knowledge of the database structure is required). In addition, network problems could be diagnosed by comparing the logs of different workstations.

You can optionally log record locks and unlocks as well as the changes. While this is not required for any functionality (and in fact will make other functions slower and use more disk space), it can be useful for diagnostic purposes if a software bug is suspected. In general, you can leave this option turned off.

Finally, one great side-benefit of the logs is the ability to completely recover after a crash, even if the crash destroys the database. As long as the log files are intact (for at least one workstation), you can restore from a previous backup and have Campground Master automatically re-apply all changes made since the backup was made.

Firewall Configuration

Firewall Basics

Since Campground Master networking uses TCP/IP communications, it's often treated as an unknown "threat" by firewall software. This is usually simple to correct by directing the firewall to allow the communications.

For most software firewalls, you simply "Allow" or "Grant" access for Campground Master when it first prompts about the unknown program, and tell it to remember this choice. If you miss this opportunity to unblock it, then you can go into the configuration of the firewall(s) you use and add Campground Master to the list of exceptions (allowed programs). Specific examples are available below. Be sure you do this on all computers running Campground Master.

Note: If a new version of Campground Master is installed, or you change between master and client, the firewall may block it even though the exception rule is still there. In this case, you'll need to go into the firewall's configuration and remove the exception rule for Campground Master. Then restart Campground Master and let the firewall ask about it again so you can grant access.

If you're using a hardware firewall (in a router box, for instance) or any firewall or gateway setup outside of the computer running Campground Master, then you may need to unblock the port being used. It uses port 6010 by default, but this is set up in the Network Setup so be sure to check which port you're using.

Windows Firewall

The Windows Firewall is standard with Windows XP and later. You need to create an "Exception" for Campground Master.

When Campground Master starts up and tries to access the network for the first time (or possibly after any update), you'll see a "Windows Security Alert" window from the firewall. Click on the "Unblock" button to enable Campground Master.

Unblocking Later -- If you missed the chance to unblock it initially, or need to see if it's being blocked, then you can go into the firewall configuration. Campground Master should be running when you do this, so the firewall can recognize it. Have our computer tech perform this procedure if you're not familiar with it.

ZoneAlarm

ZoneAlarm Pro is a common security program, and one we highly recommend. You need to include Campground Master in its list of allowed programs.

For an illustrated tutorial, see this topic on our web site:
<http://www.campground-master.com/help/zonealarm.html>

When Campground Master starts up and tries to access the network for the first time (or possibly after any update), you'll see a "ZoneAlarm Security Alert" window from the firewall. Check the "Remember this setting" box and then click on the "Allow" button to enable Campground Master.

Unblocking Later -- If you missed the chance to unblock it initially, or need to see if it's being blocked, then you can go into the ZoneAlarm program configuration. Have our computer tech perform this procedure if you're not familiar with it.

McAfee

McAfee Personal Firewall is a common security program. You need to include Campground Master in its list of internet programs and allow full access for it.

For an illustrated tutorial, see this topic on our web site:

<http://www.campground-master.com/help/mcafee.html>

When Campground Master starts up and tries to access the network for the first time (or possibly after any update), you'll see a window from the firewall stating "Application Wants to Access the Internet". Click on the "Grant Access" option to enable Campground Master.

Unblocking Later -- If you missed the chance to unblock it initially, or need to see if it's being blocked, then you can go into the McAfee SecurityCenter configuration. Have our computer tech perform this procedure if you're not familiar with it.

Norton

Norton Internet Security is a common security program. You need to include Campground Master in its list of programs and permit full access for it.

For an illustrated tutorial, see this topic on our web site:

<http://www.campground-master.com/help/norton.html>

When Campground Master starts up and tries to access the network for the first time (or possibly after any update), you'll see a window from Norton Internet Security stating "Security Alert". Under "What do you want to do?", select "Always allow connections to this program on all ports" to enable Campground Master.

Unblocking Later -- If you missed the chance to unblock it initially, or need to see if it's being blocked, then you can go into the Norton Internet Security configuration. Have our computer tech perform this procedure if you're not familiar with it.

14 Point of Sale

Overview

Point of Sale, or "P.O.S.", is an added-cost option available for Campground Master. If you have not purchased this option, then this chapter can be completely ignored (none of the included functions will be available, unless you're using the sample database demo with the P.O.S. functions enabled). The simplest way to determine if you have purchased the P.O.S. option is look at the main menu of the program. If there is not a P.O.S. menu item after Transactions on the top menu bar, then your license does not include the P.O.S. option.

P.O.S. Summary

The goal of the P.O.S. functionality is primarily two-fold -- to take the place of a cash register, with bar-code scanning capabilities, and to provide inventory database functions. It's typically recommended for use in a store or registration office check-out counter that sees a fair amount of traffic with a large number of items sold, where the required rate of sales is too great to enter each item's charges manually. However it can greatly aid convenience and reduce errors even if only a dozen or so items are sold on a regular basis.

The P.O.S. functions are separate from the reservation functions in some ways, but they also fully integrate with Campground Master. P.O.S. transactions are combined for reporting and exporting to QuickBooks, and P.O.S. sales can be added to a customer or reservation receipt (by using the added "P.O.S." button to jump into P.O.S. sales-entry mode temporarily). It's basically just another function in Campground Master -- by default, the "cash register" icon will open the P.O.S. dialog for making sales, which is similar to the Transactions entry dialog but has inventory item scanning support and other features to aid in rapid sales. P.O.S. transactions are also included in the Transaction tab view reports, with additional filtering and grouping options available for detailed inventory sales reporting.

The P.O.S. option also adds support for a bar-code scanner and pole display (both optional). The pole display is also used by the normal Transactions dialog for reservation check-in, etc., if the P.O.S. option is present. (While hardware support for a receipt printer, cash drawer, and credit card reader are also important for P.O.S. functions, those are included even without the P.O.S. option.)

The key features added by the P.O.S. option are:

- A cash-register-like interface for entering sales
- Bar-code scanner support
- Pole display support
- Inventory database for scanner support, price/descriptions, quantity on hand, etc.
- Automatic discount pricing based on several factors
- Inventory tracking and reporting functions
- Inventory reporting/filtering of Transactions
- Inventory import from CSV or tab-delimited text files
- Vendor purchase order printing, receiving and reporting

Setting Up For P.O.S. Use

You'll find most of the setup functions for P.O.S. in a special section of the Maintenance menu, with some settings appropriately located under new "P.O.S." tabs in Program Options and Printing Options. Setting up the P.O.S. falls into 3 general areas:

- Hardware setup
- Database fields and options setup
- Inventory setup (and/or importing from another database)

For complete information on setting these up, see the P.O.S. Setup section.

P.O.S. Functions

Overview

Basic P.O.S. functions include sales entry, reporting, and purchase order functions. Most of these can be found under the P.O.S. menu on the main menu bar. The one exception is transaction (sales) reporting, which is done using the Transactions tab view along with all other financial reports in Campground Master.

Added Shortcuts and Helpful Tips

There are some additional shortcut keys added for the P.O.S. functions:

- **Ctrl-T** -- Re-opens the last **Transactions** added or viewed (sales ticket)
- **Ctrl-I** -- Find Inventory
- **Ctrl-L** -- Find (Look up) Receipt

Here are some other helpful keys you can use in various functions. They're not all new, but listed here as a refresher:

- **F4** -- This hasn't changed, it's still the same as clicking the cash register icon on the toolbar. But with the P.O.S. option it now opens the new Point of Sale dialog instead of the normal Unbound Transactions dialog (unless this is changed through Maintenance / Program Options / Functions). So at a busy P.O.S. workstation, you'll be using F4 a lot (or you should be), unless you prefer clicking the icon with the mouse.
- **F4** inside Transactions -- F4 also opens the P.O.S. dialog when you're inside the Transactions dialog for Reservations or Customers (same as clicking the P.O.S. button inside that dialog).
- **F8** -- Use this to print a receipt in the P.O.S. dialog (it also does the default Print function in just about any other dialog, as it did before).
- **Ctrl-Enter** -- This is the same as clicking the Done button (or Save) on most dialogs.
- **Esc** -- This is the same as clicking Cancel on most dialogs (or Close, if there is no Cancel button).

Sales Entry -- Point of Sale Dialog

The Point of Sale dialog is the "cash register" interface of the program, where you enter sales or return items.

This dialog can normally be opened with **Alt-.** (the Alt key with the period key), or with the **F4** key, or by clicking the cash register icon on the toolbar. (This depends on the settings in Maintenance / Program Options /

Functions -- it might be set to open reservation transactions instead.) You can also open it from the menu, P.O.S. / Sales Entry.

Many of the functions in this dialog work the same as the Transactions dialog for reservations, customers, and unbound transactions. Functions that work the same won't be covered again here, like printing receipts, opening the cash drawer, viewing transaction details, entering payments and refunds, etc. -- see the main Working with Transactions chapter for the details of those functions.

This dialog has some special features to save time and support functions more like a cash register. It supports entering special charges, credits and discounts just like the Transactions dialog, but those can be disabled or restricted to certain operators to further simplify the interface.

Note that if this dialog is opened for previous transactions (a sale already completed), most functions will be disabled -- you can't add more inventory items or charges, and may not be able to delete any transactions. This is usually only done for reference purposes or to return items.

Entering sales for customers or reservations

If you want to add P.O.S. transactions to a reservation (to combine them with their reservation receipt for instance), or if you want to add the merchandise to the customer or reservation balance without entering payment in full at this time, then you can open the normal Transactions dialog for that reservation or customer first -- then click the P.O.S. button at the top of the Transactions dialog (or press **F4**).

Alternatively you can use the Select Customer or Select Reservation button to choose where the POS transactions will go. You can do this any time before printing or closing the P.O.S. dialog. Once a customer or reservation is selected you can also Change the selected customer or reservation if necessary, but again this must be done before saving the transactions or printing a receipt.

If you find that you almost always want to apply P.O.S. transactions to reservations instead of anonymously, then you may want to change the settings so that the cash register icon (and the **F4** key) open Reservation transactions first. This will allow you to find the reservation to apply it to at that time. You can still enter anonymous P.O.S. sales by going through the P.O.S. menu when needed. Alternatively you could leave the settings for the cash register to do anonymous sales, but always use the Rack or On Site list to locate the reservation first, and right-click to get to its Transactions before entering P.O.S. sales.

Scanning or entering search terms

The main feature of the P.O.S. dialog (in fact the primary benefit of the P.O.S. system as a whole) is the easy selection of inventory items from the database and automatic addition of those items to the "ticket", with the price, taxes, and any applicable discounts. With the addition of a bar code scanner, and optionally a receipt printer, cash drawer and pole display, it becomes a fully functional cash register which is also tied into the inventory tracking. This is all handled through the simple "Scan" text entry box.

Note: If you prefer, you can allow sales entry with no inventory tracking at all. This would be done using the Other Charges button, with Continuous entry enabled. See below for details.

If you're using a bar code scanner, all you have to do is make sure the text cursor (a little blinking vertical line) is in the Scan box, then scan the item's bar code. The cursor is actually returned to the Scan box after every action, so you rarely have to worry about that in.

If you don't have a scanner, or if the item doesn't have a bar code, simply enter some word or partial word that should be part of its item code or description, like "ice" or "shirt", and press the **Enter** key.

When an item is scanned or a word is entered, one of four things can happen:

- If the item scanned is found in the database, and it's an exact match with the item's code, and it's the only exact match -- the item will be automatically added to the ticket, just like in store check-outs. The description and price will be shown, with any known discounts, and applicable taxes added at the bottom. If sounds are enabled, a beep will indicate that it was added automatically. (If an item has multiple codes entered, it will check each of them for being a match.)
- If more than one exact item code match is found (for instance if you have the same item listed more than once because it requires selection of color), then all matches will be shown in a list. If sounds are enabled, a different sound will indicate that your attention is required to select the appropriate item.
- If no exact match is found, it will check the database to see if the item code or description for any items contain the text or code you entered (a partial match). If only one partial match is found, and if the Program Option is set to auto-add a single partial match, it will be used automatically. Otherwise, if any partial matches are found they will be listed for you to select one. Even if only one partial match is found, unless the Program Option is set to auto-add single partial matches it will not be automatically added because it's only a partial match -- you must confirm it by selecting it from the list.
- If no exact match or partial match is found, the selection list will appear but will show a message that there is no match. A different sound will indicate no match, if sounds are enabled.

In addition, you may be able to view your entire inventory list by simply pressing Enter without entering any text. This is an option that can be disabled if your inventory is very large (see [Maintenance / Program Options / P.O.S.](#)).

Selecting Items

If a list is shown to choose from after scanning or entering text, just use the arrow keys or the mouse to select the one you want, press **Enter** (or double-click on the item), and it will be added to the ticket. You can also [Cancel](#) if you want to just try again, or click [Details](#) after selecting an item to see more information before making a selection, or even to make changes in the inventory data (if your access level allows it).

If you want to try finding the item a different way, for instance if you don't know the name but want to browse items by Item Class, click [Find More](#). This will open the [Find Inventory](#) dialog to help you locate and select the item to use.

You may also have the option to [Add New](#) if your access level is high enough. In this case, the Edit Inventory dialog will open with a new inventory record and the code you entered or scanned will already be inserted. If you complete the information and [Save](#) it, then that new item will immediately be added to the ticket. Or you can [Cancel](#) to simply return to the P.O.S. dialog without saving or adding the item.

Adding or Changing Quantities

If more than one of an item is being sold, you can save time and space on the receipt (and space in the database) by entering a quantity for it instead of scanning/entering it multiple times. To do this, enter a number in the [Quantity](#) field **before** scanning or entering it. The quantity cannot be changed once an item is added to the ticket.

Tip: Press **Shift-Tab** or **Alt-Q** to move from the Scan field to the Quantity field, then just type the number and press Enter to get back to the Scan field.

If you forget to enter the quantity before scanning an item, you can also change it later. Make sure the item to be changed is highlighted in the list, and click the [Change Item Qty](#) button. A window will appear where you can enter the new quantity.

Discounting Items

If you have set up Item Discounts for items that are always applied or depend only on the quantity purchased, those discounts will be deducted from the ticket and added to the receipt automatically when applicable.

If there are automatic discounts that only apply to certain Discount Types, such as seniors, employees, club members, etc., then you must select the discount type used **before** scanning the items. This is important -- discounts will not be automatically applied if you change this after adding the items to the ticket. (This also allows you to change it for different items, for instance if you know a senior discount is best for some items and the member discount is better for others.) To select the discount, click on the Discount type used field with the mouse and select the discount from the list. You can also press **Alt-U** to jump to the list and use the arrow keys to select the appropriate item (**Alt-down** arrow will open the list up to make selection a little easier).

There is also a function to manually discount items. (This can be disabled or may only apply to certain operator access levels.) To add a manual discount, select the item in the transaction list to be discounted and click the Discount Item button. An "Enter Special Discount" dialog will appear, where you can select the appropriate category, discount type, description and amount or percentage of discount. The category will default to the same as used for the item (recommended). After making the selections, click Save and the discount transaction will be added.

Note that there are no safeguards in discounting items, so this should only be allowed for managers or other trusted people. For instance, a discount can be entered that's larger than the price of the item, or multiple discounts can be added for a single item. Of course they are all recorded as entered, so accountability is still there.

Discounting multiple items at once (percentage only)

It's also possible apply a percentage discount to many items at once. Just select the item(s) to be discounted, click Discount, and enter the discount information as above. The main difference is that you will only be able to enter a percentage, not a fixed amount per item (since they may be different prices). Note that it will not combine all of the discounts to a single line -- it will still add individual discounts to each item as if each was done separately. This allows you to remove/return individual items later, and also generate correct reporting for sales of each item.

Non-Taxable

If the Program Option has this option enabled, and if the operator has a sufficient Access Level, then this option will be shown at the top next to the Discounts selection. Check this box to enter items as Non-Taxable.

Note that it only applies to items added to the sale while the Non-Taxable box is checked -- so you could do a sale where some items are taxed and others are not. For tax-exempt customers, you would check this box before entering any items. It will remain checked and apply to items added until unchecked, or until the sale is completed. It will always start a new sale with this box unchecked.

Voiding Items

If you entered an item and want to remove it from the sale, there are two ways to do it - Void or Delete.

If you have a sufficient access level, then you can select the item in the transaction list and click the Delete Selected Items button at the bottom. Simply confirm the prompt and it will be removed, along with any applicable taxes and discounts.

If you don't have access to delete items, or if you prefer to show that it has been voided on the receipt, then select the item and click the Void Selected Item button. Instead of removing it from the list, an additional

transaction will be added with a negative quantity to credit the item, and it will show "Void:" in the description. Voids done this way are also recorded in the transactions, for reporting and historical purposes.

Voiding the Sale

If you wish to void the entire sale instead of individual items, simply click the Cancel button. All transactions entered will be deleted without saving them. Note that it's possible to void the sale even after a payment is entered (depending on the settings and your access level), unless it was a credit card payment that was already processed and authorized.

Other Credits

If the function is enabled and you have sufficient access, you can use the Other Credit button to enter special credits. This is usually used for coupons or other special cases. Note that credits entered this way are not applied to any particular item and will not reduce the price of an item, so the item's full price will still be counted in sales reports. It also won't reduce the taxes calculated. However it will reduce the amount to be paid and will thus affect Receipts reports appropriately. Credits are generally reported in their own category, so they can be applied to your accounting as needed.

As with discounts, there are no safeguards on entering credits, so you may want to only enable this and allow access as you feel comfortable.

Other Charges

If the function is enabled and you have sufficient access, you can use the Other Charge button to enter charges without selecting an item from the inventory.

This function can be used to enter miscellaneous charges (sales) that have no related inventory items. It works basically like the Charges on the main Transactions dialog, opening the Enter Charge dialog for the details, but with a couple extra features. The main addition is the Continuous entry option. With this checked, the Enter Charge dialog will re-open immediately after each charge is entered, until you click Cancel to stop entering charges. You can also select the Same Category option to make it keep the same category selected subsequent charge entries.

For even more rapid price entry, you can select a default Transaction Category for other charges (see Maintenance / Program Options / P.O.S.). When this is set, the category is pre-selected on the Enter Charge dialog and the cursor starts in the Amount field. Simply enter the amount and press **Enter** (assuming quantity 1, and assuming the taxes selected by default are correct). In this mode, it's basically like a cash register where you can just enter one amount after another. You may even use this mode to skip inventory tracking altogether if you prefer.

Memo

As with the main Transactions dialog, you can use this function to enter notes with the ticket. Memos don't appear on the receipts unless you select the 'Print' option when you enter the memo.

Refund Payment

This is only enabled if there is a credit balance (e.g. after returning an item), so you can enter the refund given to the customer.

Cash / Credit Card / Other Payment

Use one of these to enter the payment for the sale. This is basically the same as for Transactions, but there are a couple a special options that apply only to the P.O.S. dialog. Depending on the options selected, it may print a receipt and/or close the P.O.S. dialog immediately after entering the payment.

The difference between the cash/credit/other buttons is that the cash & credit buttons will pre-select the payment type and start the input cursor in a more appropriate field. Other Payment is the general purpose payment entry which can be used for any payment type.

If you're processing credit cards with Debit Cards enabled, then instead of one "Credit Card" button there will be 2 buttons -- "Credit" and "Debit". The Debit button pre-selects the debit card payment type and is ready for you or the customer to swipe the debit card.

Note: If you are accessing the Point of Sale from the P.O.S. button on a reservation's or customer's Transactions dialog, you don't need to enter the payment here. Just click Done to go back to the Transactions dialog, and enter a payment for their complete bill at one time. (This is the only time the Point of Sale dialog can be closed without payment in full, without canceling.)

Shortcut Keys

The following function keys can be used as shortcuts:

F5 - Enter Other Charge

F6 - Enter Cash Payment

F7 - Enter Credit Card Payment (or Other Payment if credit card processing is not enabled)

F8 - Print

F9 - Open cash drawer

F10 - Done

Temporary Operator Override

If you're entering a POS sale but you're unable to complete a function due to your Operator Access Level, you don't necessarily have to go all the way out to have a manager log in. Just right-click in the caption bar, and select "Temporary Operator Override". That will allow someone to log in for this function only -- after leaving this dialog, it will revert to the previous operator automatically.

Returning POS items

Returning POS items is done through this P.O.S. Sales Entry dialog. You can either just start normally with a blank sale, or you can locate the original receipt and re-open it to return items. The latter method is recommended, so you can verify the amount paid, any discounts applied, etc., especially if they don't have their original receipt.

To return an item without finding the original receipt first, enter the POS Sales Entry and simply enter a **negative** Quantity (e.g. -1) and then scan or enter the item. A negative charge will be shown, with appropriate taxes also deducted. Then enter a Refund Payment and print a receipt if they need one.

To return an item and record it with the original receipt, use the Find Receipt function to locate the original receipt. This can be located by the receipt number or item code, and/or date. See the Find Receipt section for details. Once the item is located, this P.O.S. dialog will be opened with the complete original receipt. Then you can select the item to be returned (click on its "Charge" transaction line) and click the Return Selected Item button.

When you click Return Item, a dialog will show the description to be used on the receipt for the return, and allow you to enter the quantity returned (in case the original entry was for multiple items). Click Save, and new transactions will be added with appropriate negative charges and taxes. Any automatic discounts that were based on quantity may also be adjusted. Then enter a Refund Payment and print a receipt if they need one.

Note: The Return Item function adds new transactions, never affecting old ones. This way it's impossible to affect reporting for previous days or shifts -- the return is a new transaction. While it may be possible to use Delete if your access level allows it, this should not be used for simple item returns.

Also note that when viewing an old receipt, there is a new option next to the Print Receipt button, "Print only new transactions". This is the default, and recommended for returns. Only the returned item and refund transactions will be printed, instead of the entire original receipt.

Sales Entry - Enter Item Price

A small dialog for entering a price will appear if you've selected an inventory item having the "Ask for price" option (see Inventory Item Setup). This would typically be for miscellaneous fees or other items that don't have a fixed price. Simply enter the total price and press **Enter**.

Sales Entry - Enter Item Qty

A small dialog for entering the quantity sold will appear if you've selected an inventory item having the "Ask for Qty each sale" option (see Inventory Item Setup). This would typically be for bulk-type items like gasoline or propane or items sold by weight. Simply enter the total qty and press **Enter**. It defaults to 1, so you can just press Enter (or click OK) to leave it as 1. Clicking Cancel will cancel that item completely.

Selecting a Reservation or Customer

Depending on how you use the Point of Sale functionality, you may never need to select a reservation or customer for the P.O.S. transactions. In this case, they're treated like Unbound transactions, or simple cash register sales.

However there may be times when you're ringing up a sale and realize that the customer wants to put it on his reservation account instead of paying for it now. If you know this ahead of time, then it's generally easier to bring up the Transactions entry dialog from the reservation itself, then go to P.O.S. from there. But if you're already in the Point of Sale dialog then you can also select the reservation (or customer) account from there.

When you use the Select Customer or Select Reservation button from the Point of Sale, a Find Customer or Find Reservation dialog will appear where you can select where the P.O.S. transactions should go. Simply enter the name or other criteria to find the desired customer or reservation, make the selection and click Use (or just double-click on the desired customer).

Credit Balances and Limits

After selecting a Customer or a Reservation, it will check to see if they have a credit balance. (If a Customer is selected, it checks for a credit applicable to **only** the Customer, ignoring any balances on Reservations for that customer). If there is a balance, it will show you the amount of the balance (so you know how much can be applied without additional payment).

Depending on the Access Levels settings and your operator level, you might be limited to that credit balance, i.e. it may not let you finish the sale with a balance greater than the credit available. If that's the case, you need to enter a payment for at least the difference, to avoid going over the credit balance. However if your operator level allows you to go beyond that credit balance, you will be able to complete the sale and have the

balance due be added to the Customer or Reservation balance. In that case, it may show you a warning or continue with no warning, again depending on the Access Level settings.

Changing the Customer or Reservation selected

If a reservation or customer has already been selected, their name and site number will appear on the Sales Entry dialog instead of the Select buttons, along with a Change button. However the Change button will be disabled if it's too late to change the account for this sale (e.g. if editing an old receipt, or if you're already coming from the Reservation Transactions dialog). When the Change button is clicked, a different dialog will appear so you can select either a reservation or customer, or simply clear the selection.

To select a reservation, click Find Reservation and locate the desired reservation with the normal Find Reservation functions. Once selected, that reservation's information will be shown for verification. You can change it by using Find Reservation again.

Likewise, use Find Customer to select a customer's account -- remember however that this will only put it on the customer, not their reservation, so this should only be used in special cases (for instance if they don't have a reservation).

If you decide not to put the P.O.S. sale it on an account, click the Clear Selected Reservation and/or Customer button to clear the selection and then click Use for POS to reset it to a basic P.O.S. sale.

There are Access Levels that can be configured to not allow P.O.S. sales on customers and/or reservations unless they're paid in full at the time (with a warning prompt if not paid), or to not allow them at all. There's also an access level that will allow an unpaid sale without prompting at all.

Find P.O.S. Receipt

The Find P.O.S. Receipt function is opened through P.O.S. / Find Receipt on the main menu. This is exactly the same as the Transactions / Find Receipt, except that it opens with the "POS Only" option selected already. For details, refer to the Find Receipt function under *Working with Transactions*.

This function is used to locate a previous P.O.S. receipt. This is especially helpful for returns, but it can also be used for other purposes. For instance, by entering an item code and perhaps a date range, you can get a list of all receipt line-items for that item.

Find Inventory Item

The Find Inventory Item function is opened through P.O.S. / Find Inventory Item on the main menu. It can also be opened by pressing the **Ctrl-I** key.

This dialog is generally used to locate an inventory item in the database for performing some function, and is also used from inside other functions such as Edit Inventory, Create Purchase Orders, Enter Inventory Adjustment, as well as when Find More is used inside the P.O.S. Sales Entry dialog search results list.

It can also be used to print simple inventory list reports according to a specific filter (or no filter at all, to list all items). While that's also possible with the Inventory Check-list report, there is a difference -- In this dialog, each item shows its price and price with tax (public information). The Inventory Check-list report is designed for internal use, showing Cost and Total Cost for inventory valuation. As with all other reports, the items listed can be printed, exported, or copied to the clipboard.

Normally you would just enter a search term or scan an item into the text box. However you can also filter items using the Inventory Filter, either in combination with a search term or instead of a search term. The filtering allows you to locate items by many different criteria.

When you find the inventory item you're interested in, double-click on the line or select the item and press the View or Use button -- depending on how it's invoked, this "OK" function is different. If it's used from inside another function, then the "OK" function is to close the Find dialog and use that item for the indicated function (e.g. add it to the purchase order). If it's invoked from the top level (main menu or Ctrl-I), then the OK function is to view the item's details.

Also, if the Automatically use/act if unique match box is checked, and if the search results in a single match when you press Enter (or scan an item), then you won't have to select it from the list -- it will perform the "Use" action on it automatically (e.g. View the item).

When you're finished with finding items, or don't want to use any of those found for the function you came from, click Close.

Once a list is displayed, you can print the entire list, or print a Form for any inventory items selected, by clicking the Print List / Forms button. Therefore this dialog can also be used to print out filtered item list, or for batch-printing Forms or labels for selected items. Once this button is clicked, the Select Form dialog will allow you to choose what to print -- the list in grid format or a form for each selected item.

Inventory Filter

This dialog is used from several different places. It's used to define a filter for finding or listing only particular items from the inventory database.

Nearly every field in the inventory database can be filtered using this function. The "Reset" state will be no filtering at all (include all items) **except** inactive items. Note that even a reset filter must have some things checked, so that all possible combinations of conditions are included (e.g. all cases of what taxes apply).

The filter selections should be simple enough to understand. It's just a matter of figuring out which conditions you want to check. Quantities can be filtered by any range (minimum and maximum values. Keep in mind that **all** "Filter by" conditions selected must be met for an item to be included. For instance if you enter both a price and a cost range, an item will not be included unless it meets **both** the price and the cost criteria.

To filter by class, category, park (if applicable) or vendor, just select the ones that you want to include -- use Ctrl-click to select multiple items. If no items are selected, than that's actually the same as selecting none of them (all items cases be included). You can filter by more than one field at a time also -- for instance to show only items belonging to a particular class **and** from a particular vendor.

Text Filtering -- Click this button to set up a text search so it only include inventory items that have a data field matching certain text. See Text Filtering for details.

Inventory Reports

Overview

Several different inventory reports are available, for various functions. Most have some common functionality, such as Inventory Filtering to select which items are shown in the report.

Note: Any changes to a report's Inventory Filtering is remembered, local to the workstation. While this allows you to customize the conditions of each report, even to be different on each workstation, this also can result in a report being "broken" if the filter is tampered with or changed by accident. If this happens, simply change the filter according to the default filter for the report, as indicated for each report below.

Inventory List Reports

There are 3 different "List" reports that list individual items with details of each item appropriate for the report. You can then [Print](#) the report or use [Export List](#) to save it to a CSV file. Whenever you have finished generating reports of a particular type, just [Close](#) the dialog.

There are a couple options on each of the reports:

[Change Inventory Filtering](#) -- Each report has a default filter for that particular report, but you can use this button to change the Inventory Filtering to determine what items are shown.

[Show 'calculated' current cost](#) -- By default, the [Cost](#) value set in the Inventory Details of each item will be used for the "Cost" and "Total Cost" columns (unit cost and total on-hand cost, assuming you purchased at the current cost). However if you've set a Cost Accounting Method (other than "None") in Program Options, this option will be available to show the current on-hand cost calculated according to that accounting method.

Inventory Check-list report

This report simply lists all inventory items (except inactive ones, unless Filtering is changed to include them), with the quantity on hand, cost and total cost of the complete inventory. This can be used as a simple list of all inventory items, or as a check-list for taking inventory.

The default filter is simply a "reset" filter -- Click the [Change Inventory Filtering](#) button and click [Reset Filtering \(include all\)](#) to get it back to the default.

Items below re-order threshold

This report lists all inventory items which have a quantity on hand lower than (or equal to) the re-order threshold. It won't show any inactive items, and it won't show any that don't have an on-hand or re-order quantity entered. It shows the on-hand and re-order quantity, along with the minimum re-order quantity, cost, and vendor. This can be printed or exported for placing orders (assuming you're not using the internal purchase orders).

The default filter is a reset filter with only one change. To get the filter back to the default, click the [Change Inventory Filtering](#) button and click [Reset Filtering \(include all\)](#), then **uncheck** the box to [Include if qty > re-order threshold](#).

Old stock

This report lists all inventory items that have not been sold in the past 30 days, that show at least one remaining in stock. It won't show any with no quantity on hand, and it won't show any that haven't been sold in the past 30 days. The price, last sale date, and qty/cost information is shown so that you can determine the value of the old stock.

Note that if an item has no sales in the system (no transactions for it), then it will be listed because it's assumed that it has never been sold since it was entered in the system. This may list items recently entered in the database, so be sure to take that into account when it shows a blank last-sold date.

The default filter is a reset filter with two changes -- To get the filter back to the default, click the [Change Inventory Filtering](#) button and click [Reset Filtering \(include all\)](#), check [Filter by the number of days since last sold](#) and enter 30, and check [Filter by qty](#) and enter 1 for the minimum, 0 for the maximum.

Inventory Sales Reporting

As with all other transactions, reporting for sales and receipts for point of sale transactions is done through the Transactions tab view. These are meant to be accessed through the Transactions Tab view, but there's an entry in the menu for people looking for it for the first time.

With the P.O.S. option, some special settings and filtering options are available for reporting inventory sales, and for separating P.O.S. transaction reports from non-P.O.S. reports if necessary. For details on using the Transactions tab view for reports, see that section in the main *Dynamic Interactive Report Screens* chapter.

Most sales summary reports needed are available by clicking the Summary Options button on the Transactions tab view. This options dialog has a number of Quick-Reports for the most common tasks, and a number of other options available for customizing reports.

The most common reporting task for a P.O.S. system is a report for balancing a cash drawer after a shift or at the end of the day. This is no different for the P.O.S. as it is for other transactions (presumably all types of transactions take place on the same computer or computers). Use the Receipts by Payment Method button to generate a report showing the net amount of receipts for each payment method (cash, check, Visa, etc.). This will show the daily total for each day selected in the dates. If you need a report for a particular operator shift, then open the Filter (or More Filters) and select the operator for which to report totals.

Another common report is an inventory sales report. Two new quick-reports available with the P.O.S. option -- Inventory Sales by Amount and by Quantity. Simply click the appropriate button and set the dates or other filtering as needed. These will report sales for each inventory item. If you have a lot of inventory items, you'll probably want to go back to the Summary Options and select the Hide items with zero totals option, so it only shows the items sold that period. By default, these reports show both the inventory item code and the description. You may prefer to show it by only the code or only the description -- this is another summary option.

You can also report inventory sales according to class or vendor instead of by item. Class is probably more interesting if you have a large inventory. A Vendor report might be useful for showing which vendors are supplying you with the hottest items, or that you might be able to get a better deal from by leveraging your the volume of sales. For either of these reports, select the Inventory Sales quick-report and then go back to Summary Options to change the Group totals for each selection.

P.O.S. Transaction Filtering

A few special options are available in the Filter for P.O.S. transaction reports. You can opt to include either P.O.S. transactions or non-P.O.S. transactions (or both), in case you want to see separate totals for reservation income vs. merchandise income. (Of course this is also usually apparent if you report by transaction category, but that only works for reporting charges, not receipts.)

If you include P.O.S. transactions, you also have the option to filter the transactions by inventory. Thus you can report sales details for a single vendor or certain vendors, selected inventory item classes, filter by tax categories, and other possibilities.

Detail Reports

Transaction details are reported as usual, but with the P.O.S. option you can add columns for inventory item code, description, class, and vendor. Use the Detail Options button to select these columns in detail mode.

On-Hand Report

This report is accessed through the menus *P.O.S. / Inventory Reports / On Hand by date*.

Select the desired options in the dialog, then click the Generate Report button (if Auto-Generate is not enabled). You can then Print the report or use Export List to save it to a CSV file, or adjust the options to generate other reports. Whenever you have finished generating reports of a particular type, just Close the dialog. The last options you selected (except for the dates) will be saved for that report and used as the default the next time you open that report dialog.

The report is a grid-based summary report similar to the Summary Transaction reports in the Transaction tab. Thus it uses the same print option settings and have the same look.

Pre-requisites for Accurate On Hand Reporting

On Hand can be an important accounting report, and Campground Master has powerful features for tracking it -- however, as they say with computers, "garbage in, garbage out". In order to use this effectively, a lot of things need to happen. Most of this is essentially the same requirements as Cost of Goods Sold, so see that report for more details (especially if you need to see Cost on hand, not just Quantity).

At the very minimum, you will need to have the On Hand Quantity field enabled for inventory items, and each item will need to have an accurate count in it. Even if you don't use Campground Master for cost accounting, this will allow you to at least get total units on hand. If you also have the Cost field enabled and enter a Cost for each item, you can get the approximate value on hand using that cost, using the default Cost Accounting method of "None" (set in Program Options / P.O.S.). However this is not likely to be sufficient for tax purposes if you're not using the full inventory tracking functionality.

Report Values

The basic function of the report is to report the Inventory On Hand at the end of each date, month, quarter, or year as needed.

Value to Report -- This selection allows you to report by quantity, cost, or price, as needed for accounting:

Quantity -- Reports the quantity on hand at the end of each period.

Cost -- Reports the total calculated cost of all items on hand at the end of each period. Note that the values shown will be the cost calculated according to the **Cost accounting method** selected in Program Options. Thus it can change in unusual ways day by day depending on the method being used, especially if using the Weighted Average method.

Price -- Reports the total value of all items on hand using the sale price known at the time. Note that this uses the Price field currently in the Inventory Item record, as well as any adjustment entries with price changes (working backward) to get previous prices on earlier dates. It does not use the actual price that items sold for in Transactions.

Remember, the value shown under each date column is the on-hand value at the **end** of that period -- e.g. if it's by Month, that's the value at the end of the last day that month.

Show the change in value each period -- You can check this to get a quick look at what items are changing inventory on a regular basis, especially since any cells with no change will be blank.

Show "Average" column / Show "Total" column -- You can have it show a final column with the Average value (or "Total" if showing changes). Be aware that this will be the **Average** value over the time period reported (unless you're using the "Show the change" option). Make sure you don't accidentally use this as the ending total for the period -- use only the values under the dates, and the values under the last date (or month/quarter/year) will be the "final" On Hand value.

Report Options

The report has some common settings as you see throughout Campground Master:

From/To Dates -- You can select any start and end date for the report. There are also helper buttons to quickly select Month-to-Date, Year-to-Date, Last Month and Last Year date ranges. Note that if you accidentally try to report on future dates, the results will be zero or undefined.

Summarize period -- You can summarize the reports by days, months, quarters, or years. This results in one column (or row) for each day, month, or year of the selected date range. Keep in mind that the date range selected takes precedence. So for example if you summarize by month and selected the range 4/1/2001 to 5/1/2001, it will show April and May months in the report but will be reporting for only one day in May due to the 5/1/2001 ending date.

Auto-Generate -- By default, you must click the Generate Report before it will calculate a report and fill the grid, since some reports can take a significant time to generate. If you're reporting on a small date range or using a fast enough computer, you can select the auto-generate option so that the report is refreshed every time you change one of the options. This can be useful for experimenting with the controls to see how they affect the report before generating a report for a large date range.

Group Total for Each -- The results can be grouped by Inventory Item, Transaction Category, or Item Class.

Hide groups with zero totals -- This will prevent showing group rows or columns (but not date summaries) that have a zero value for the entire date range.

Show Item: Codes / Descriptions -- Select whether you show the Item Code or Item Descriptions, or both, in the first column. If neither is selected, it will use the Description. This only has an effect if grouping by Inventory Item.

Inventory Item Filtering -- This button will open the Inventory Filtering dialog and allow a variety of filtering options.

Note that the "Use filtering" box must be checked in order for the filtering to take effect -- this is checked automatically if you edit the filter, but you can easily toggle this option on and off to see how the filtering affects the report.

There's also an option to "Save filter" for next time, which can be checked when you set up a filter that you want to use as the default. If this is checked when you close the report, then the filter will be saved and re-used the next time you run the report (and "Use filtering" will be checked automatically.) If you make changes to the filter but this box isn't checked upon exit, then the changes won't be saved but the previous filter will still be loaded (but will no longer be used automatically -- just check "Use filtering" again to re-activate it next time).

Cost of Goods Sold report

This report is accessed through the menus *P.O.S. / Inventory Reports / Cost of Goods Sold*.

Select the desired options in the dialog, then click the Generate Report button (if Auto-Generate is not enabled). You can then Print the report or use Export List to save it to a CSV file, or adjust the options to generate other reports. Whenever you have finished generating reports of a particular type, just Close the dialog. The last options you selected (except for the dates) will be saved for that report and used as the default the next time you open that report dialog.

Pre-requisites for Accurate Cost Accounting

Cost of Goods Sold is an important accounting report, and Campground Master has powerful features for tracking it -- however, as they say with computers, "garbage in, garbage out".

At the very minimum, you will need to have the On Hand Quantity field and the Cost field enabled for inventory items, and each item will need to have an accurate On Hand count in it. If you have a Cost value entered for each item that represents the average cost of each item, you can get approximate results using the default Cost Accounting method of "None" (set in Program Options / P.O.S.). However this is not likely to be sufficient for tax purposes, especially if you're not using the full inventory tracking functionality.

In order to use this effectively for tax purposes, a lot of things need to happen:

1. Select your Cost Accounting Method, in Maintenance / Program Options / P.O.S., so it knows how to calculate it. There are several popular methods, and Campground Master has implemented all of the common methods.

We won't define these in detail here, since your accounting person should already understand these in depth. Just know that these calculate the cost using information from sales, purchases and other Adjustments entered throughout the year. For most methods, the order of actions is important. For the order, Campground Master uses the Date (and in some cases, the Time) of the record, whether it's a sale Transaction, Purchase Order "received" date, or the date & time of the Adjustment entry.

- FIFO (First In, First Out) -- assumes the earliest purchased items are the first sold, using the "perpetual inventory system" method.
- LIFO (Last In, First Out) - assumes the last purchased items are sold first, using the "perpetual inventory system" method.
- Moving Average -- uses an average that is recalculated each time purchases are made. Also known as the AVCO Perpetual inventory system.
- Weighted Average -- calculates an overall average at the end of each accounting period. Also known as the AVCO Periodic inventory system.

There is also a "None" option, selected by default, which just uses the Cost from the inventory record and assumes no real-time tracking is done. This is not a valid accounting method, and is only used to make things faster for those who don't care to use the more advanced tracking and reporting functions. You can also get approximate results with this if you are not looking for perfect accounting results.

2. Initial inventory setup / starting point. Beginning Inventory must be known to calculate COGS. If you started out setting On Hand inventory properly which you first used Campground Master and have maintained this ever since using Purchases, etc, then you may be all set. Otherwise, you will likely need to enter **retro-active adjustments** to get to a good starting point.

3. Tracking Purchases. It will need to know when you purchased items, how many and at what cost. If you use the Purchase Orders functionality, and also use the Receiving function, then this will also do the tracking for you (once you've started using version 11 or later). Otherwise, you will need to Enter an Adjustment for each purchase to properly track it for cost accounting. It should go without saying that entering the accurate Cost of each purchase is also important.

4. Tracking Sales. As long as you're using the P.O.S. Sales Entry dialog for all merchandise sales, then this is being tracked for you. However if you enter a sale without using the P.O.S. (or use "Other Charge" to enter an item's charges instead of properly scanning or selecting it from inventory), then inventory will not be properly adjusted.

5. Tracking other Adjustments. To have a proper inventory count, it will need to know about any other changes to inventory on hand -- theft, removed for use, damage, etc. These should be entered as Adjustments whenever possible. The closer to the actual time of the event that you enter it, the better.

6. Final Inventory Count. -- For the absolute best accuracy, any business should be doing an inventory count at the end of the reporting period. If you do this, enter the results of the Count through Enter Adjustments so it can update the inventory and track that as a change in on-hand quantity.

IMPORTANT -- This and other inventory reports assume that the current On Hand quantity, based on the current quantity for the item in the Edit Inventory Item dialog, is correct. It then works backwards from that to "back out" sales, purchases, and other Adjustments each day. Therefore it's extremely important that the you maintain the on-hand quantity by entering adjustments (purchases, losses, inventory counts, etc) as they occur. See the section on Entering Inventory Adjustments for more details.

What this doesn't track

Campground Master does a good job of tracking the "cost" of items and quantities. What it won't do is more complex and detailed accounting for things like materials used to manufacture items for sale, etc., or other expenses involved in inventory management.

Report Values

This report has columns for the primary amounts needed for Cost accounting for tax purposes (assuming of course you've been using the system properly to track all inventory changes so that it has all of the necessary information). Except for Cost of Purchases, these values all use the appropriate calculations as described above for the selected Cost Accounting Method.

Beginning Cost -- Total cost of all inventory on hand for that item, class, or category, as of the beginning of the first day of the report range.

Cost of Purchases -- Total cost of all purchases during the reporting period.

Ending Cost -- Total cost of all inventory on hand for that item, class, or category, as of the end of the last day of the report range.

Total COGS -- Cost of Goods Sold, equals Beginning Cost + Purchases - Ending Cost.

Note that it's possible for COGS to have a negative value. This can happen for instance if the calculated value of current inventory is larger than what was paid for it, e.g. due to a large cost increase being applied to older inventory -- essentially a capital gain on inventory, which would show up as income when you subtract the negative amount on your taxes!

Report Options

The report has some common settings as you see throughout Campground Master:

From/To Dates -- You can select any start and end date for the report. There are also helper buttons to quickly select Qtr-to-Date, Year-to-Date, Last Qtr and Last Year date ranges. Note that if you accidentally try to report on future dates, the results will be zero or undefined. naturally you should set these properly for your accounting reporting period.

Auto-Generate -- By default, you must click the Generate Report before it will calculate a report and fill the grid, since some reports can take a significant time to generate. If you're reporting on a small date range or using a fast enough computer, you can select the auto-generate option so that the report is refreshed every time you change one of the options. This can be useful for experimenting with the controls to see how they affect the report before generating a report for a large date range.

Group Total for Each -- The results can be grouped by Inventory Item, Transaction Category, or Item Class.

Hide groups with zero totals -- This will prevent showing group rows or columns (but not date summaries) that have a zero value for Cost of Goods Sold. Note that this will also hide items that have starting and ending inventory, but if the start and end are the same then the total COGS will be zero, so they will be hidden.

Show Quantities -- Select this option to show various quantities that may help explain where the totals come from -- it will show the quantities for beginning & ending On Hand, as well as the number sold, purchased, and any Adjustments. (You can refer to the Adjustment reports to investigate those details).

Show ending Unit Cost -- Select this to see the ending calculated cost per unit for the period. Note that this will depend on the Cost Accounting Method selected (not the Cost value from Inventory Item details). It's primarily useful for Weighted Average reporting.

Show Item: Codes / Descriptions -- Select whether you show the Item Code or Item Descriptions, or both, in the first column. If neither is selected, it will use the Description. This only has an effect if grouping by Inventory Item.

Inventory Item Filtering -- This button will open the Inventory Filtering dialog and allow a variety of filtering options.

Note that the "Use filtering" box must be checked in order for the filtering to take effect -- this is checked automatically if you edit the filter, but you can easily toggle this option on and off to see how the filtering affects the report.

There's also an option to "Save filter" for next time, which can be checked when you set up a filter that you want to use as the default. If this is checked when you close the report, then the filter will be saved and re-used the next time you run the report (and "Use filtering" will be checked automatically.) If you make changes to the filter but this box isn't checked upon exit, then the changes won't be saved but the previous filter will still be loaded (but will no longer be used automatically -- just check "Use filtering" again to re-activate it next time).

Adjustment Detail Report

This report is accessed through the menus *P.O.S. / Inventory Reports / Adjustment Details*.

This report shows "raw" Adjustment record information. While it was intended as more of an auditing tool, it can also be useful for getting a list of all Purchases or Loss adjustments, for instance. You can then Print the report or use Export List to save it to a CSV file. Whenever you have finished generating reports of a particular type, just Close the dialog.

The report has some common settings as you see throughout Campground Master:

Find by Date -- You can select any start and end date for the report, or uncheck the option to show all dates.

Filter by Inventory Item -- You can enter a search term or scan an item into the text box to only show adjustments with items matching that code, or with the "scan cost" field containing the text entered.

Filter entries according to ... Adjustment Filtering -- You can further customize the report for the Types or Reasons of adjustment, or even the Operator who entered it, as well as ranges of adjustment values, etc. Inside this filter, you can also set up Purchase Order or Inventory Item filtering.

There's also an option to "Save filter" for next time, which can be checked when you set up a filter that you want to use as the default. If this is checked when you close the report, then the filter will be saved and re-used the next time you run the report (and "Use filtering" will be checked automatically.) If you make changes to the filter but this box isn't checked upon exit, then the changes won't be saved but the previous filter will still be loaded (but will no longer be used automatically -- just check "Use filtering" again to re-activate it next time).

Show Item: Codes / Descriptions -- Select whether you show the Item Code or Item Descriptions, or both, in the first column. If neither is selected, it will use the Description.

Adjustment Summary Report

This report is accessed through the menus *P.O.S. / Inventory Reports / Adjustment Summary*.

This report can summarize "raw" Adjustment record information. While it was intended as more of an auditing tool, it can also be useful for getting a total of all Purchases or Loss adjustments, for instance. You can then Print the report or use Export List to save it to a CSV file. Whenever you have finished generating reports of a particular type, just Close the dialog.

Value to Report

For all Adjustments found according to the date and other filtering, the report can total various values from the adjustments. Note that in all cases, zero values will be shown as blank in the grid, to make it easier to see what changes actually took place.

Change in Qty on hand -- If the adjustment changed the quantity, will show the amount that the quantity changed.

Change in Cost each -- If the adjustment changed the cost, will show the amount that the cost changed from the previous cost value. Note that this is cost values in the Inventory Item record, not a calculated cost using the cost accounting method.

Change in Price each -- If the adjustment changed the price, will show the amount that the price changed from the previous price value. Note that this is price values in the Inventory Item record, not related to actual sale transactions.

Number of adjustment entries -- the number of Adjustment records found in the time period.

Adj. effect on total Cost* On Hand -- This calculates the total effect (of all inventory on hand at the time) in total Cost On Hand -- in other words, the difference in Cost On Hand before and after the adjustment. This uses the Cost Accounting method selected in Program Options. Note that this is generally due to an On Hand Quantity adjustment, since a Cost adjustment is ignored for most accounting methods (since it's only a change in the inventory record's cost, not real accounting cost). However for Weighted Average accounting, Weighted Average Cost adjustments can have an effect.

Adj. effect on total Price On Hand -- This calculates the total effect (of all inventory on hand at the time) in total price of all items on hand -- in other words, the difference in Price On Hand before and after the adjustment. Note that this is generally due to an On Hand Quantity adjustment, but could also be due to a Price adjustment.

Adj. total raw cost (Qty x Cost) -- This is the non-calculated cost change of the adjustment. Instead of a calculated cost as mentioned above, this calculates using only the Cost from the Inventory Item record (and could also report a change due to a Cost adjustment).

Report Options

The report also has some common settings as you see throughout Campground Master:

From / To Date -- You can select any start and end date for the report.

Adjustment/Item Filtering -- You can further customize the report for the Types or Reasons of adjustment, or even the Operator who entered it, as well as ranges of adjustment values, etc. Inside this filter, you can also set up Purchase Order or Inventory Item filtering.

There's also an option to "Save filter" for next time, which can be checked when you set up a filter that you want to use as the default. If this is checked when you close the report, then the filter will be saved and re-used the next time you run the report (and "Use filtering" will be checked automatically.) If you make changes to the filter but this box isn't checked upon exit, then the changes won't be saved but the previous filter will still be loaded (but will no longer be used automatically -- just check "Use filtering" again to re-activate it next time).

Summarize period -- You can summarize the reports by days, months, quarters, or years. This results in one column (or row) for each day, month, or year of the selected date range. Keep in mind that the date range selected takes precedence. So for example if you summarize by month and selected the range 4/1/2001 to 5/1/2001, it will show April and May months in the report but will be reporting for only one day in May due to the 5/1/2001 ending date.

Auto-Generate -- By default, you must click the Generate Report before it will calculate a report and fill the grid, since some reports can take a significant time to generate. If you're reporting on a small date range or using a fast enough computer, you can select the auto-generate option so that the report is refreshed every time you change one of the options. This can be useful for experimenting with the controls to see how they affect the report before generating a report for a large date range.

Group Total for Each -- The results can be grouped by Inventory Item, Transaction Category, Item Class, Adjustment Type or Adjustment Reason.

Hide groups with no adjustments -- This will prevent showing group rows or columns (but not date summaries) that have a no adjustments for the entire date range.

Show Item: Codes / Descriptions -- Select whether you show the Item Code or Item Descriptions, or both, in the first column. If neither is selected, it will use the Description. This only has an effect if grouping by Inventory Item.

Purchase Orders

Overview

Campground Master isn't designed to be a complete accounting system like QuickBooks, so it doesn't handle things like cost accounting, inventory valuation, average-cost or LIFO inventory cost updates, etc. However, some basic functionality has been included for easily entering order details and printing purchase orders that you might be able to use when re-ordering inventory -- or at least serve as a list for each vendor that you can give to the person in charge of ordering.

Of course these are simply called purchase orders due to their basic function, as an "order" to purchase inventory items. If you don't actually issue purchase orders but rather pay up front, that's between you and the

vendor. Basically a "purchase order" here is a list of inventory items that you want to order from each vendor, with basic vendor information included to look like an official purchase order. You can add some specific information on the orders, either by vendor or for all orders. You can also add extra line-items like shipping or other charges so that they appear on the printed orders.

The basic procedure for handling purchase orders is:

1. Select the items from inventory you want to order (and/or automatically add all items below their re-order threshold or other filter criteria).
2. Adjust the quantities and cost of each item if necessary, and perhaps change vendors as needed.
3. Add any extra line items (shipping, fees, etc.)
4. Create the purchase orders (this creates the order records and puts them in the Print dialog ready to be printed).
5. Print the purchase orders.
6. Print mailing labels or envelopes if needed.

Later...

7. When an order is received, go into the Receiving function, verify the quantities, and 'Receive' the items to update inventory and confirm the order has been fulfilled.

Note: The Campground Master database doesn't store complete purchase orders as a unit -- it works just like transactions, so that it simply keeps a list of the line items. Each line item is given an appropriate P.O. #, and that's what ties the line items together. It's smart enough to assign the same P.O. # to every line item ordered from the same vendor (in a single session), and when these are printed they will come out as coherent orders for each vendor. However there is no function that will show a complete purchase order on a single dialog -- they will always be listed as individual line items, similar to the Transaction History for a customer, or the Transactions tab view. You can locate purchase order items by P.O.# of course, to show all items that were on an order and even re-print it if necessary.

Create Purchase Orders

This dialog is accessed through the main menu: P.O.S. / Purchase Orders / Create Purchase Orders.

Here you will create a list of line-items that you need to order. This is usually for items in your inventory database, but you can also add any non-inventory items you need to.

Each line item can be ordered from a different vendor, and they can be all mixed up. When the orders are printed, it will group all items for a given vendor into a single order, assign an appropriate P.O. # to all of the items for that vendor/order (unless you enter P.O. #'s manually), and print out one order form for each vendor represented. If there are 10 line items from 3 different vendors, it will gather those items into 3 orders, one for each vendor. (Technically it groups them by P.O. number, but those are generated automatically to be different for each vendor so it's the same thing if you're leaving those as "automatic" -- see below for more information.)

The order of the items does not matter as far as vendors, but the order is preserved for the items of a single vendor. Therefore you should make sure that additional items like shipping charges are added at the bottom (and be careful about re-sorting them, which could move items around in the list).

Order Date

You can specify the actual date of the order by setting the date at the top of the dialog. Normally it's the current day, of course, but you may have a reason to change the date, for instance if you need to keep it consistent with the date of the check.

P.O. Numbers

Unless you already have a P.O. # system that you maintain, you'll probably want to let Campground Master automatically assign P.O. numbers. The numbers are created based on a format that you specify in Maintenance / Printing Options / Purchase Orders. Until you actually create the orders, the number will be shown in this list as "(automatic)".

If you prefer to assign specific P.O. numbers, simply click on that field and type the P.O. number you want. Be aware that if you enter your own P.O. numbers, then it will print separate orders based on those, not based on the vendors. For instance, If you enter different P.O. numbers for two items from the same vendor, two different orders will be printed. Likewise, it will combine any with the same number -- so if you enter the same number for items from different vendors, they will be printed on the same order anyway!

Adding Items to an Order

There are a few different ways you can add items to your order, described below. Remember that none of this is saved until you click the [Create & Print Orders](#) button at the bottom, so you can add and delete order items as needed until you get it the way you want, or cancel it altogether by closing the dialog without creating them.

Any time an item is added from inventory, the Qty (to order) will be set to the item's re-order minimum value, if it has one. The Cost will also be filled in with the cost value in the database, and the vendor information will be filled in. Note that the Vendor's Stock # and Vendor's Description may default to the Item Code and Item Description if those fields are blank for the inventory item, depending on the Printing Option settings.

Once an item is added, you're free to edit some of its details -- the Qty and Each values can be changed, you can select a different vendor, and change the Vendor's Stock # and Vendor's Description if needed. The P.O. Number can be set also, if necessary (see above).

If you hold the mouse cursor over the Inventory Item field of any item, the description and quantity on hand will be shown in a pop-up window. Note that if an item does not have an item code, its record number will be shown instead, like "<#4>". This doesn't matter to the order (the Vendor's stock #/description will be used), and you can see the description by holding the mouse over it. However we generally discourage entering items without an inventory code of some kind, even if it's a just word like "shirt".

If you need to see the Inventory Details or Vendor details for any item, click on the row once to highlight a field, then click the corresponding [View](#) button at the bottom. You can edit the inventory or vendor record if needed. Note that changing the item's cost or re-order minimum will **not** change the order cost or qty for line items already added. Changing vendor information will affect the corresponding information printed on the orders, however.

The four different ways to add items to an order are described below:

Auto-Add all items below threshold

For "automatic" ordering, just click this button. It will add all inventory items that show a current on-hand quantity equal to or less than the re-order threshold for that item. Of course this must be used with care -- it won't know if items have already been ordered, so it could result in duplicate ordering.

- **Adjusting the filter** -- You can also adjust the criteria for this auto-add function, for instance if you only want to include items of a certain class, or items that have less than a certain quantity (regardless of the re-order threshold). This is done by changing the filtering -- click [Adjust Filter for items to auto-add](#). After the filter is changed, the Auto-add button will change to "Auto-add all filtered items" to indicate that it's not just items below the re-order threshold anymore. Note that any changes to the filter will be saved, and used next time also.
- **Resetting the filter** -- If you want to reset this filter to just be items below the re-order threshold, then open the filter ([Adjust Filter](#)) and click [Reset Filtering \(include all\)](#), and **uncheck** the box for [Include if qty <= re-order threshold](#).

Find Inventory Item to Order

Use this function to locate and add a particular item to the order. This will open the Find Inventory dialog, where you can scan an item or enter a search term, or list items according to a filter specification. (Or show all inventory items by unchecking both check-boxes.) Once the desired item is located, double-click on that row (or select it with the keyboard arrows or mouse, and press Enter or click Use). It will be added to the order with the cost, re-order minimum, and vendor information from the inventory record.

Find Previously Ordered Item

Use this function to locate a previous order and add an item to a new order, with the same quantity, price, and vendor as before. The Find Purchase Order dialog will be shown, where you can use various search methods to locate the item you want.

Add a Non-Inventory Item

Use this function to add any miscellaneous items to an order, such as products not in the inventory database, shipping charges, fees, etc. It will add a blank line to the order, and you simply fill in the information for each field. These will appear on the order like any other items.

Creating the Orders

Once you've added all of the items you want to order, click the Create & Print Order button. If there are any errors (missing information), you will be prompted to correct the errors and try again. When everything is validated, all of the order items will be saved and it will open them in the Print Purchase Orders window (see that section for details). The list there will be nearly identical, except that the real P.O. number will be filled in for any that were automatic, and the items cannot be edited.

Print Purchase Orders

This dialog is accessed through either the Create Purchase Orders function or the Find/Print Purchase Orders function, from the P.O.S. / Purchase Orders menu.

If no items are selected in the list, then it will print orders for all items shown. If you only want to print orders for some items, select those items before clicking a Print button.

When the orders are printed, it will group all items with a given Purchase Order Number into a single order. Generally all orders created for the same vendor at the same time will have the same P.O. number.

Note that there is limited space on an order form for items, and it won't automatically print multiple pages. If there are too many items for one page, you can separate them into two order pages by selecting some of them to print each time. Tip: If they are all grouped together in the list, just click, hold the button down, and drag the mouse to select all of the ones you want to print.

Notes

You can enter notes to print on all of the orders, below the list of items. If it's a short note, you can just type it on the Notes field. Otherwise, click the "..." button next to the Notes field to open a multiple-line window and enter the information to be printed. If you need different notes for each order, then select and print only the appropriate items at once, changing the Notes text for each selection group you print.

When you're ready to print, just click the Print Orders button. You can also print labels or envelopes for the associated vendors if needed, and print or export the list of order items.

Find / Print Purchase Orders

This function is accessed through the main menu: P.O.S. / Purchase Orders / Find/Print Purchase Orders. This same dialog is also used for the Find Previously Ordered Item in the Create Purchase Orders function.

This function is generally used to locate previous purchase order items, either for reference, reporting, or to re-print an order. You can search for orders by several options, including date, inventory item code (which can be scanned from a bar code), P.O. numbers, vendor stock numbers, or a variety of Purchase Order Filtering options.

All of the relevant information about each order item will be shown. You can sort the items by any column if needed, and print or export the list you want it for a report.

If you want to view the inventory or vendor details for any item, simply select the row and use the appropriate View function at the bottom. You can also Delete items if necessary, but remember that this actually deletes the order -- it doesn't just remove it from the list!

If this was invoked from the Create Purchase Orders function to find a previously ordered item, then select the item you want and click Use (or press **Enter**).

If you're locating purchase orders to print, select all of the items you want to print and then click the Print Orders button at the bottom. (Or to print all of them, just click Print Orders without selecting any.) This will copy the order items into the Print Purchase Orders dialog, where they can be printed.

Purchase Order Filter

This dialog is invoked from either the Find/Print Purchase Orders function, the Purchase Orders Outstanding function, or Print Vendor Labels/Envelopes. It's used to help locate specific orders, and perhaps to generate a specific report.

Order items can be filtered by nearly any of the order information by selecting the appropriate options. For instance you can select a particular vendor (or multiple vendors), select orders by quantity ordered, date, or the operator who created the order.

You can also use inventory filtering to look for orders according to the item ordered -- particular classes, cost, and so forth.

To reset the filter to include all purchase orders, click the Reset Filters button (this also resets any inventory filtering).

Text Filtering -- Click this button to set up a text search so it only include purchase orders (or their linked inventory items) that have a data field matching certain text. See Text Filtering for details.

Purchase Orders Outstanding (Receiving)

This dialog is accessed through the main menu: P.O.S. / Purchase Orders / Purchase Orders Outstanding (Receiving). This function is the easiest way to update your inventory to reflect an order received (assuming you generated the orders through Campground Master to begin with).

When this dialog is opened, it will be ready to take a scan code or other search term to find purchase orders for. If you're using a scanner, you can simply scan the item. If there is only one outstanding P.O. found for it, then it will immediately open the dialog to enter the quantity received (or click the "All Received" button if all received). If more than one match is found, it will list any found so you can select the one to receive. Alternatively, you can search by P.O. number or the Vendor's stock number, assuming you have that information in the database.

If you prefer, you can uncheck the "Find by" box and it will show all ordered items in the system that have not been completely fulfilled, sorted by date. (Order items that have no quantity will not be shown, such as shipping). If necessary you can change the filtering criteria by clicking Change Purchase Order Filtering. Note that unlike most other functions, changes to this filtering are **not** saved -- it's reset each time the dialog is opened.

When entering the quantity received, you can also change the Cost of the received items, just in case the cost is different than what was on the order.

Note that when you receive items through this function, an Adjustment record for tracking and reporting is also created automatically. The Adjustment Type will be "Purchase", and the Reason will be set according to the defaults in Program Options.

Receiving All Items

If an entire order is received from a vendor, the easiest way to "receive" it is to sort by P.O. number, locate the items for the order received, select all of those items (click on the first one, and Shift-click on the last one), and click Receive All of selected items. The Qty Received values will be updated and the inventory on hand is immediately updated for those items (if it's an inventory item).

Items are not immediately removed from the list when received, so you can print a report if needed. If you want to clear all of the items that have now been received in full, click the Refresh List button.

If only part of an order is received, you can also just select those items received (use Ctrl-click to select individual items if they aren't contiguous in the list). Again, you can use the Receive All of selected items function if the entire quantity was received for each of the selected items.

Entering Qty Received

If only some of an individual item were received (for instance 25 out of 100 ordered), then select the item and click Enter qty received of item selected. A dialog will appear showing the number ordered and previously received. Enter the amount received **this shipment**, and the remainder will be shown. Press **Enter** or click Save and the inventory will be updated.

Deleting Order Items

If necessary you can completely delete an order item. While not generally recommended (because it loses all record of the item being ordered), you may need to do this if an item you ordered will never be received. Select the items to delete and click the Delete Selected Items button to delete the ordered items. Note that if a quantity has already been received, the inventory on hand has already been updated -- so deleting the order item will **not** subtract the items from inventory.

Print Vendor Labels & Envelopes

This dialog is accessed through the main menu: P.O.S. / Purchase Orders / Print Vendor Labels (or Print Vendor Envelopes). It's also used if Print Labels or Print Envelopes is done from Find/Print Purchase Orders.

Vendor labels and envelopes are basically printed the same way as Customer labels and envelopes (from the Reports menu), so some of the details can be found in that section.

If you're accessing this function from the main menu, all vendors will be shown by default. You can also select which vendors to be printed by using either Purchase Order filtering or Inventory Item filtering, or both. If both

are selected, a vendor must meet both criteria (pass both the filtered orders and the filtered items) in order for it to be included.

If you're accessing this function through [Find/Print Purchase Orders](#), then only vendors for those orders will be listed (if you uncheck the option to filter out duplicates it will show a separate line and print a label/envelope for each order item, but that would probably be pointless). The filtering options will not be shown.

Note that the vendor contact names are not printed on the labels, since it's assumed that the contact names could contain multiple names or other information that wouldn't be appropriate for the labels.

You can view or edit any vendor's information by double-clicking on the corresponding line.

When ready to print, select the vendors to be printed (or don't select any to print them all), select the format to use from the drop-down list, and click the [Print Labels](#) or [Print Envelopes](#) button.

Entering Inventory Adjustments

Campground Master tracks "Adjustments" to inventory on-hand quantity, cost, and price. This Adjustment tracking, which includes the time and date of the adjustment, is essential for reporting functions such as On Hand by Date and Cost of Goods Sold. Adjustments can also be reported separately to get things such as a Loss report or Purchases report -- see Adjustment Reporting.

IMPORTANT -- Some Inventory Reports assume that the current On Hand quantity, based on the current quantity for the item in the Edit Inventory Item dialog, is correct. It then works backwards from that to "back out" sales, purchases, and other Adjustments each day. Therefore it's extremely important that you maintain the on-hand quantity by entering adjustments (purchases, losses, inventory counts, etc) as they occur. If you have not been doing this (e.g. because your previous version didn't support it), see below for **retro-actively adjusting inventory**.

Entering Adjustments

When you are in Edit Inventory Item, you can click the "Adjust..." button to change the On Hand quantity. You can also manually change the Cost or Price on that dialog directly, to change the "current" cost or price, which will also be tracked with an Adjustment entry.

There are also several functions for entering Adjustments to inventory on-hand quantities or costs, accessed in the menu under P.O.S / Enter Inventory Adjustments. These will open the Find Inventory Item dialog, where you can scan an item or search for an item to adjust.

Once an item is scanned/selected, a dialog will open to enter the [Adjustment Type](#), a [Reason for the adjustment](#), and the changes in quantity/cost/price as appropriate. Note that depending on the adjustment type being entered, some values may not be available for entry -- for instance, when entering an Inventory Count adjustment, only the Quantity can be entered, not a Cost or Price change.

"Cost" note -- The Cost value set in the Inventory Details of each item will be used for the "Cost" column (current unit cost for purchasing). However if you've set a Cost Accounting Method (other than "None") in Program Options, there will be an option available to **Show Calculated cost** as of a particular date. This will add an extra "Calc. Cost" column, showing the unit cost according to the selected cost accounting method, as of that date. This is especially important if using the Weighted Average method, and wish to create a new accounting period set-point cost (see below).

There are several fixed Adjustment Types. These determine how the adjustment is handled for various calculations, and can also be used for reporting to get all adjustments of a particular type.

Inventory Count -- This is used when you're doing a physical inventory count and need to manually correct the On-Hand quantity to the physical count.

Loss -- This can be used to enter known losses to inventory on hand due to theft, gifting, etc.

Purchase (Receiving) -- If you're using the Purchase Order system, then an Adjustment is automatically created when you do Receiving through Purchase Orders Outstanding (Receiving). If you're not using Purchase Orders, or when you purchase inventory without a P.O. entered in Campground Master, then you should enter the purchase through this Adjustment type. Otherwise it cannot calculate Cost of Goods Sold or Cost On Hand correctly.

Weighted Average Cost -- This is a special type of Adjustment that's only used if you're using the "Weighted Average" method for Cost of Goods Sold accounting. It should be used to "set" the cost at the end of an accounting period, which will be used as the beginning inventory cost for the next period. Otherwise the Cost of Goods Sold report will not be correct.

There is also a special button "Reset Weighted Average Cost to the shown calculated cost" available, which should be used at the end of each accounting period to fix a "set-point" cost for the next accounting period when using Weighted Average cost accounting. You can use it to automatically create Weighted Average Cost adjustment entries for all items (or items currently 'selected' in the list) in one step, assuming the "Calculated cost" shown is correct (which it should be if the proper procedures have been followed since the beginning of the accounting period). Before using this button, also make sure that the "as of" date show for "Show Calculated cost as of" is the *last day of the previous accounting period*, since that's both the date used for calculating the cost shown (and used for the adjustment) as well as the date used for the adjustment entries.

Other adjustment (Manual adjustment) --This can be used for some other kind of change in quantity, cost, or price that you want to track but doesn't fall into one of the categories above.

Once a Type is selected, the Reason will be set to the Default Reason selected for that type in Program Options. However you can select a different Reason as needed, or Edit the pick list to add more reasons for your reporting needs.

If you are attempting to enter a correction on some past date, you can enter the appropriate Date of the adjustment (beware of how this will affect the reporting, though).

When changing the Quantity for an adjustment, you can either enter the Quantity to add amount (which can be negative for reductions, such as a Loss adjustment), or you can enter the New quantity directly (it will calculate the added number accordingly). Note that only the Quantity to add number is actually recorded in the adjustment -- so for instance if you're entering an old adjustment for a loss (e.g. back-dating it), then the New quantity is not necessarily what the quantity would have been on that past date, since the "Old quantity" shown is always the current on-hand quantity.

Finally, you can optionally enter reference information or notes, which will only be seen on the Adjustment Details report for historical/auditing purposes.

Retro-actively adjusting inventory to correct quantity and cost

Prior to version 11, Campground Master did not "track" inventory other than through sales. It was up to you to update the quantity on hand manually (or by using Purchase Orders with Receiving). There was no facility for entering adjustments, and no way to report an On Hand amount for prior dates, let alone Cost of Goods Sold.

Starting State

If you wish to use the On Hand reporting or Cost of Goods Sold, then the first thing you need to do is get your inventory to a correct "starting state". For the purposes of the Cost of Goods Sold calculations, the starting values of Cost and On Hand for each item (in Edit Inventory Item), before any Adjustments are applied, is treated as the beginning inventory and purchase cost of those units. Once you get the starting state set, all you have to do is enter Adjustments when an event occurs (usually a purchase or inventory count, but you can also enter adjustments such as removing damaged inventory), and Campground Master will take care of the rest.

If you are about to start a brand new accounting period and don't need to report prior periods, then all you may need to do is make sure the current On Hand quantity and Cost is correct. However, if you want to try to use Campground Master for reporting the current period that started in the past, then a little more care must be taken when making adjustments.

Important -- If you change the Cost (or Price) of an item through Edit Inventory Item, that will actually create an Adjustment. Likewise, if there is already an On Hand quantity for the item, it can only be changed on Edit Inventory Item by entering an Adjustment. If the accounting period of interest has not started yet, then that won't be a problem. Otherwise, you need to be sure to back-date any Adjustments created when getting those values to the desired "starting state" to some date prior to the accounting period. For On Hand quantity, you can do this when entering the adjustment. For Cost changes, you will need to do this through Raw Data Tables / Point of Sale / Inventory Adjustments. Alternatively, if you don't want to mess with Adjustments to get to your starting state, you can use Raw Data Tables to edit the inventory On Hand and Cost values manually, spreadsheet-style.

By the way, don't forget to set your Cost Accounting Method in Program Options!

Entering Historical Adjustments

Depending on how precise you want to be on daily amounts and various reports, you can either enter one massive adjustment or try to enter "transactional" adjustments to re-create history.

Note that as you enter Adjustments, the current On Hand quantity will change for the adjustment as if it happened today, even if the adjustment itself is back-dated. For instance if the current on-hand quantity shows 100 and you enter a back-dated Adjustment where you purchased 200 units, then the quantity will change to 300 (even though you may really only have 100 left due to later sales). This will be dealt with at the end -- for now, only worry about the quantity "added" for each adjustment

Purchases

If you have been using the Purchase Orders already, and assuming you use the Receiving function through Purchase Orders Outstanding to update the on-hand quantity as items are received, then you're in luck -- Campground Master will automatically create Adjustment records for all past Purchase Order "Received" amounts. This will give you instant purchasing history accurate to the date received.

If you have been using Purchase Orders but not Receiving them, or if you don't use Purchase Orders at all, you would enter Adjustments (through Enter Inventory Adjustments / Receiving). For the most accurate reporting, enter each purchase with its associated, quantity, cost, and date received, for each item. If you receive items often and don't want to go to that trouble, then you could enter one Purchase Adjustment, dated to the beginning of the period, for the total quantity purchased for the period. Be aware however that some Cost accounting methods are sensitive to when a purchase is made, especially if the cost has changed.

Losses and other manual adjustments

These are generally important for cost reporting, and depending on the cost method and the reporting needed, the timing could also be important. As with Purchases, you need to decide whether it's important to replicate history with accurate timing on these. If not, then skip them and just do the final Count entry.

Count adjustments -- Final adjustment

As with other adjustments, Count adjustments only record the **change** in quantity -- so it's probably not useful as a historical entry of prior re-counts -- however this is an easy way to get your on-hand quantity correct again after entering other historical adjustments that likely changed it.

What you want to do is enter a Count adjustment, setting the New Qty to the actual current quantity. However, you're really wanting to fix the starting quantity before your other adjustments were entered (assuming your on-hand quantity was reasonably accurate prior to entering back-dated adjustments). Therefore it's important to set the Date of this count to be 1 day (or more) **before the beginning of your current accounting period**. For instance, if you plan to use reports for the year of 2020, enter December 31st 2019 as the date of the count. That will enter an "adjustment" on that date of whatever quantity was needed to get the current on-hand set back to the New Qty after all other adjustments.

Set Weighted Cost

This is a special kind of adjustment that's only needed if you're using the Weighted Cost accounting method (it's ignored if that method is not selected in Program Options). This only sets a Cost "set-point" -- it does not change a quantity, and does not change the "current" Cost for an inventory. It's used exclusively for Cost of Goods Sold or other Cost reports.

To set a prior weighted cost starting point, enter an adjustment back-dated to the day before the current accounting period (and of course enter your Weighted Cost to use for beginning inventory, as calculated by your accountant for the end of the prior period). This must be known separately for each item in order to set proper starting costs.

P.O.S. Setup

Overview

This section covers the setup functions added by the P.O.S. option for setting up your inventory database, various options for sales entry and receipts, and hardware.

Note that the setup for a cash drawer, credit card reader and credit card processing software are covered in the main Maintenance section since they are part of the main Campground Master program, not optional features.

Receipt printer setup is generally a matter of just connecting it like other printers and installing driver software. You will probably also need to adjust the various settings under [File / Printer Setup](#) and [Maintenance / Printing Options](#) for the 3" receipt printer. There is also a configuration for the message at the bottom of the receipts, under [Maintenance / Park Setup](#).

Hardware Selection

Below is a list of suggested equipment to use for the P.O.S. system, with choices in some areas depending on your budget and preferences. If you need help locating a supplier, please contact us. Also see our web site for updated lists and [hardware purchase information](#). We can't support any hardware you purchase elsewhere (other than the setup in Campground Master itself), so we recommend purchasing from us unless you have a local computer technician to help with hardware setup.

Which items you need for your system depend on your situation. Technically the P.O.S. can be operated without any external hardware other than a standard PC printer. In a high-traffic situation, however, we recommend that you use a bar-code scanner, a receipt printer, and a cash drawer, possibly with a pole display added for a nice touch.

A magnetic stripe reader for credit cards is only needed if you plan to process credit cards through Campground Master, and then you also need compatible processing software that works with your merchant account. See the Credit Card Processing section under Maintenance Functions for details.

Choosing Hardware Interfaces

The bar-code scanners and mag-stripe readers usually interface through USB, and the cash drawers interface through the receipt printer (assuming you use a receipt printer) which is also usually USB. If you don't plan to use a receipt printer but do want a cash drawer that opens automatically, then you will need to use a USB or serial port for the cash drawer.

Parallel or serial ports will work for receipt printers, but you need to make sure the computer has a real parallel or serial port, not a USB port conversion device.

Suggested Equipment

The items listed below are models that we sell -- see our web site for more details. You can contact us directly to purchase these items, or contact your own vendor. These are all "basic" models, so there may be additional options available (for instance different colors, added stands, etc.). The sales person can help you with options and other questions.

Bar code scanners (USB "keyboard emulation", triggered or auto-trigger, decoded)

Metrologic 9520 laser, long range

Receipt Printers (USB, with cash drawer port)

Epson U200 series, a basic impact printer

Epson TM-88iv, a fast thermal printer

Cash drawers (interface to receipt printer or USB)

APG Multipro Series, various sizes and media slot options

Pole display

Logic Controls PD-3000, serial or USB

Mag stripe readers (track 1,2 & 3)

Magtek USB "keyboard emulation" 2-head bidirectional mini-swipe

Important: For the mag stripe readers and bar code scanners, it's imperative that they are "keyboard emulation" interface types, not "HID" (Human Interface Device).

If you're unsure about whether a particular device not listed here will work with the software, please contact us. Also see our web site for updated lists and vendor information.

Pole Display Setup

If you want to use a pole display with your P.O.S. system, so the customer sees the merchandise prices and descriptions, total due, etc., then you have to configure it through this dialog (Maintenance / Pole Display Setup).

When a pole display is properly set up, it will show items as they are entered or scanned, payments made, total amount due, etc. This will work in both the Point of Sale dialog and the normal Transactions dialog for reservations, etc.

Campground Master will work with nearly any pole display that can be connected to a serial or parallel port, presuming it's a 2-line, 20-characters-per-line display. It will also work with USB pole displays, provided a "serial emulation" driver is used -- contact technical support for details. Every brand of pole display is controlled with a different set of commands, but you simply need to enter those commands here so Campground Master knows how to communicate with it. The seven commands required are described below.

Settings

Important -- All of these settings are local to each workstation. If you have more than one workstation on a network, each one must be set up individually (so they can have different displays or use different ports on each workstation as needed). Also note that the settings are saved according to the workstation's ID (see Network Setup), so if that is changed for any reason then the pole display settings may need to be changed also.

Since many commands contain non-printable characters like ESC, CR, LF, etc., they must be entered in a special code. This code is a backslash, followed by an 'x', followed by 2 hexadecimal digits representing the character (byte) to be sent. For instance a linefeed (LF), which has the value 10 (0A in hexadecimal), should be entered as **\x0a**.

Note: Use the backslash (\), **not** the forward slash (/), for the special codes. The forward slash is usually on the key with the question mark (?). The backslash, which you need to use, is sometimes above the **Enter** key, and sometimes located other places.

Pole display is present -- this must be checked in order for Campground Master to send data to a pole display. All other settings are disabled unless this is checked. Note that if a pole display is removed, or the database is moved to a computer without a pole display, it's a good idea to uncheck this so it won't send pole display commands to the port. Otherwise it may lock up the program or affect other devices that are connected to the same port number.

Interface port -- select the port that the display is connected to. If it's a USB pole display, and assuming you have installed the serial emulation driver (required), select the com port assigned to the emulation driver.

Baud, Parity, Data bits, Stop bits -- These only apply if the interface port is a serial port (com1 through com8). Enter the appropriate values according to your pole display manual. (Most are set up for 9600 baud, no parity, 8 data bits, 1 stop bit.)

Reset Command -- Enter the command sequence you want to send to the display to clear it and get it ready for other commands. This often includes commands to turn off the cursor, put it in a non-scrolling mode, and clear the screen. This command will actually be sent every time something new needs to be displayed. To make sure it's correct, you can press the Test button next to it to see what happens.

Note -- Some displays have multiple modes of operation, like scrolling vs non-scrolling, auto-scrolling, horizontal scrolling, etc., so perhaps no commands at all would be needed in some circumstances. However, since this behavior is unpredictable (by the software), it's best to make sure the display is put in a non-scrolling mode, and use whatever commands are necessary to force the text to show on line 1 and line 2.

Line 1 command, before and after -- Enter the command sequence required (if any) that needs to be sent before and after any text that you want to display on line 1 of the display.

Line 2 command, before and after -- Enter the command sequence required, after the first line is displayed, to display text on the second line. Some displays simply need a CR character (\x0d) to get to the second line. Others require that both the first and second line are surrounded by certain command characters.

Test Line 1 & Line 2 -- after entering all of the necessary commands above, click this button to reset the display and send sample text "Line 1" and "Line 2" to the display.

Automatically wraps to 2nd line -- In some cases, the text written to Line 1 will be the full 20 characters. On some displays, it will wrap to the 2nd line automatically so the Line 2 command can be skipped before the 2nd line is displayed. If this is the case, check this option.

Idle message / Command -- After a sale is complete, you may want a special message to show on the display all the time. If the display supports automatic scrolling, you could even have a message scrolling constantly across the display. Enter whatever message text you want displayed during this idle time, along with any command characters necessary to get it displayed. You should also include the commands to reset the display (it doesn't sent a Reset command before the idle command, so if you just want to leave up the last total or balance due on the display, you can just leave this blank.). You can also use the Test button to make sure it's right.

Tip: for a scrolling message, don't forget to include some extra spaces at the end to separate the end from the beginning of the repeated message.

Pole Display Example Commands

Here are examples of the recommended command settings, for 4 different brands of pole displays.

Logic Controls PD-3000:

Reset command: \x1f\x14\x11
Line 1 before text:
After text:
Line 2 before text: \x0d\x0a
After text:
Automatically-wraps: Yes
Idle message: \x1f\x14\x05 Scrolling message here \x0d

EMAX:

Reset command: \x0d\x0d!#1 \x0d
Line 1 before text: !#1
After text: \x0d
Line 2 before text: !#2
After text: \x0d
Automatically-wraps: No
Idle message: \x0a\x0a!#4 Scrolling message here \x0d

IEE:

Reset command: \x14\x0c\x0e
Line 1 before text:
After text:
Line 2 before text: \x0d\x0a
After text:
Automatically-wraps: Yes
Idle message: \x14\x0c\x0eStatic message here (no scrolling is possible)

DynaPOS:

Reset command: \x1b\x40
Line 1 before text: \x1b\x51
After text: \x0d
Line 2 before text: \x1b\x52
After text: \x0d
Automatically-wraps: No
Idle message: \x1b\x40Static message here (no scrolling possible)
 Alternatively: \x1b\x51Line 1 message\x0d\x1b\x52Line 2 message\x0d

Program Options - P.O.S.

These options are found through Maintenance / Program Options / P.O.S. (assuming you're authorized for the P.O.S. option). All of these settings affect the way that the P.O.S. sales entry dialog operates. You can set it up the way that best suits your operation, depending on whether you want to keep it simple, minimizing clicks needed to complete a sale, or whether you want all possible features available and the ability to decide exactly in what order you do things.

Note that these settings are global, so they affect all workstations in a networked environment. Also note that some of these options are further affected by the Access Levels, so even though an option is enabled here, it may not be available to certain operators.

Hide transactions for taxes on P.O.S. entry dialog -- When this is checked, the running total for taxes will show at the bottom, but the list will not show taxes. If this is not checked, then one or more tax lines will also appear in the list and will be updated after each item added. This might cause confusion, so it's best to leave this checked.

Allow a sale to be entered as non-taxable -- When this is set, a "non-tax" checkbox will be added at the top of the POS Sales Entry, so you can skip sales taxes on items even if they are normally set as taxable in Inventory Setup. An Access Level is also available, so it can be limited to certain users.

Auto-add item scanned or searched if it's the only partial match, even if it's not an exact match -- Normally if the scanned code or search term is not an exact match for the item's code or description, it will show the matching item(s) in a list to be selected. If you set this option, then if only one partial match is found, it will be added automatically rather than showing a list with just one item to select.

Warn if sale exceeds known inventory for an item -- This won't prevent the sale of an item, but pops up a warning message which must be acknowledged. While this can be annoying, it's unlikely to happen without a good reason. It's especially useful if you sell items that aren't brought up to the counter first, like ice or firewood. For instance if someone says they need 5 bags of ice, this will tell you if there aren't that many out in the freezer (assuming inventory is correct).

Warn if sale results in low inventory for an item -- This will show a pop-up warning if the item just entered is getting low. This is not recommended for a high-traffic location, since it can be annoying and time-consuming. However for lower traffic situations, especially if the manager is likely to be the one handling sales, this can be a handy reminder that something needs to be re-ordered soon.

Enable Discount Item function -- This does not affect auto-discounts (set up through the Inventory setup), but enables a special button on the P.O.S. dialog allowing one-time special discounts to be entered. This is usually only desired in a small shop where the manager has the authority to offer discounts to preferred customers, for instance.

Enable Other Credits function -- This adds a button on the dialog to allow entering special "Credit" transactions. This is typically used for coupons or gift certificates, where you need the full price of the items to be recorded for reporting (so you can't use Discount), but you want to enter a Credit so the amount actually paid by the customer is reduced.

Enable Other Charges function -- This adds a "Charge" button so that you can enter sales outside of your inventory. This is usually needed for miscellaneous charges that can't be easily inventoried. It will open the standard Enter Charge dialog where you select a category, enter a quantity and amount each, and select the taxes to apply. This can also be used to operate the P.O.S. like a simple cash register instead of entering any inventory at all, just entering amounts one after another (with the "continuous" box checked on the P.O.S. dialog).

Default transaction category for Other Charges -- This is important if you use the Other Charges for rapid sales entry. It will select this category each time the Other Charges function is used, allowing you to simply type the price and press Enter to enter a sale. Typically this would be a general category like "Misc Sales". If you want the operator to select a category each time, select the blank entry at the top of the drop-down list.

Default Adjustment Reasons -- This will open a separate dialog where you can select the "default" Reason for each of several Adjustment Types and functions. Refer to Entering Inventory Adjustments for details.

Automatically save transactions when a payment is entered -- This helps prevent "missing" transactions by accidentally clicking the Cancel button, especially if a receipt is not needed.

Automatically print the receipt as soon as the payment is entered -- This simply saves a mouse click to speed up operations, presuming that you always want a receipt printed. As soon as a payment is entered, even if it's not paid in full, a receipt will be printed.

...only if it's a credit card payment -- Select this along with the option above if you only need a receipt printed for credit card sales.

Automatically save transactions when a receipt is printed -- This option is designed to help prevent fraud (or mistakes). Once a receipt is printed for a customer, it will record the transactions immediately so that they can't be cleared out by simply canceling the dialog. The dialog will remain open, but will show the transactions as "old" -- items can still be returned and a refund issued if necessary, but that will all be recorded too. (This option does not need to be checked if the next one is checked.)

Automatically close the P.O.S. dialog when a receipt is printed -- This is commonly enabled just to save a step, since printing the receipt generally signals that you're done. However you might not want to do this, for instance if it's common for the customers to have a question about it after you print the receipt, and want the transactions to remain displayed until they leave. (Tip: **Ctrl-T** will bring up the last transactions entered, so the last sale is still only a keystroke away if you remember this shortcut.)

Automatically re-open the P.O.S. dialog after a sale is completed -- Enable this in a high-traffic situation where you just want it to keep the P.O.S. dialog up and ready for sales. If you need to close the P.O.S. dialog for other functions (assuming it's currently empty and waiting), just press the **Esc** key (or click Cancel or Done).

Allow closing the dialog (Done) without printing a receipt when a Payment or Refund is entered -- If it's common that your customer doesn't need a receipt (or you're doing some testing and don't want to waste paper), enable this option so that a sale can be saved without printing a receipt.

Enable sounds when scanning or entering items -- Some people find beeps and bonks helpful, others find them annoying. This is mostly useful if you're using a bar-code scanner, and don't want to have to look at the

screen each time you scan an item. With this enabled, a sound will indicate whether the scanned item was found (uniquely) and the charge added automatically, or whether no match was found, or whether multiple matches were found and you need to select one of them. (The sounds used are the same sounds used throughout the program and Windows in general for "Attention", "Error", and "Warning" messages.)

Show entire inventory list if Enter pressed with no scan/search text -- This should only be used when your inventory list is small, so it doesn't cause unexpected delays. If you only sell a couple dozen items and don't use a bar code scanner, then it may be just as easy to press **Enter** and then select an item from the list as it would be to type in an item code or text to search for. Of course it could be enabled even for large inventory lists, but in that case it might be better to require that at least some text be entered (e.g. they could enter "App" if they're looking for a particular kind of apple), so if they press **Enter** by mistake it doesn't cause a delay while the whole list is being loaded and sorted for them.

Inventory cost accounting method (e.g. for Cost of Goods Sold) -- This determines the calculation method used for the "Cost" figures in reports such as On Hand by date and Cost of Goods Sold. This should only be set once, and should be set according to your accounting methods. See the Cost of Goods Sold report for details.

Printing Options - P.O.S. Receipts

These options are found through Maintenance / Printing Options / P.O.S. (assuming you're authorized for the P.O.S. option). These settings are basically identical to the Receipts settings, but affect only the receipts printed from the P.O.S. sales entry dialog. Thus the P.O.S. receipts can have different defaults than receipts printed for reservations.

Before printing receipts, you should go to File / Printer Setup to configure the appropriate printer (especially if using a 3" roll paper receipt printer). See the chapter "*Setting up your Campground Database*" for details.

Note that these settings are local to each workstation, so they can be set differently for each workstations in a networked environment. They will be synchronized (applied to all workstations) along with other settings if the "Synchronize local options..." function is used under Network Functions.

These options apply mainly to the "default" receipts and Forms or any custom Forms derived from them. Custom Forms can also incorporate these settings if desired, or they may be completely ignored -- see the Forms Setup section for more details.

Point of Sale Receipt default format -- Select the receipt format you will use most often for P.O.S. sales. You can select the format any time you print a receipt (without coming back here), but setting the most common one here will save steps later, and of course is very important if you configure the P.O.S. to auto-print receipts. See the section Working with Transactions for details on each format.

Copies -- If you usually print duplicate receipts, you can change this to **2** so that you don't have to change the number of copies every time you print a receipt. (You can still change the number of copies on the print dialog when printing -- this just determines the default number.)

Always Preview Receipts Before Printing -- When this option is set, you will get the chance to preview the printout before actually printing a receipt. (This option is the only way to get a preview for receipts.) This is usually disabled for P.O.S. receipts because speed is important.

Show printer setup dialog when printing receipts -- When enabled, a dialog will appear every time you print with options for printer selection, layout, number of copies, etc. This requires an extra step to "OK" this dialog each time. By disabling this option, that dialog is skipped so there's one less mouse click required. It will use the default settings from Printer Setup for the selected receipt type and the number of copies selected above. A small "Printing" message will appear momentarily just to let you know that it's printing, since there may not be any other indication if you're not near the printer.

Combine taxes of the same kind into a single line on receipts -- When entering transactions, taxes are usually added automatically. While P.O.S. taxes are generally all combined into one transaction anyway, if you come back in to return an item, for instance, this can result in multiple Tax transactions of the same kind. This option will combine all taxes of the same type into one line (total) on the receipt. Different tax types, for instance Sales Tax and Liquor Tax, will still be on separate lines.

Show tax details on receipts -- by default, each line for sales tax or other tax category will show the amount taxed and the percentage rate, like (\$20.00 @ 8.25%). If you prefer not to have that information printed on the receipt (for simplicity), you can disable this option.

Show 'Change' amount on receipts for payments with amount tendered/change due -- When a Cash payment or other payment method with an "Amount tendered" is entered different than the amount to pay, the receipt will normally show the full amount tendered and then a separate "Change" amount that was given. You can disable this option to avoid printing the Change on the receipts and instead just show the single payment amount.

Show Receipt # on receipt -- If this is checked, a receipt number will appear on the P.O.S. receipts. This is very useful for P.O.S. receipts because if they bring back a receipt to return an item, the transactions can be found easily by entering the receipt number. Note that "Receipt #" is the default name of this field, but if you prefer "Invoice #" or some other name, you can change this by editing the name (Short Label and Report Heading) of this field under Maintenance / Define Data Fields / Transaction Fields.

Limit to the ?? most recent unique #'s -- Enter the max number of unique receipt #'s to show on the receipts. Normally it will show a list of receipt #'s for the printed transactions (see above), but if it's more than a few then it can cause the receipts to be too long for the page, shoving other information off the end. Use this to limit the number of lines used for receipt #'s. Note that POS receipts rarely contain more than one receipt # anyway (even transactions added later use the original receipt #) so this setting will usually not have any effect, but is included for consistency.

Printing Options - Purchase Orders

These options are found through Maintenance / Printing Options / Purchase Orders (assuming you're authorized for the P.O.S. option). These settings affect only the purchase orders printed from the P.O.S. / Purchase Orders functions.

Note that these settings are local to each workstation, so they can be set differently for each workstations in a networked environment. They will be synchronized (applied to all workstations) along with other settings if the "Synchronize local options..." function is used under Network Functions.

These options apply mainly to the "default" receipts and Forms or any custom Forms derived from them. Custom Forms can also incorporate these settings if desired, or they may be completely ignored -- see the Forms Setup section for more details.

Copies -- designates a default number of copies to print for each purchase order.

Always Preview Orders Before Printing -- When this option is set, you will get the chance to preview the printout before actually printing orders. This is a good idea so you can verify what's on each order, and in particular make sure that the orders aren't too long, filling up and overflowing a page.

Show printer setup dialog when printing orders -- When enabled, a dialog will appear every time you print, with options for printer selection, layout, number of copies, etc. This requires an extra step to "OK" this dialog each time. By disabling this option, that dialog is skipped so there's one less mouse click required. It will use the default settings from Printer Setup for the selected receipt type and the number of copies selected above. A small "Printing" message will appear momentarily just to let you know that it's printing, since there may not be any other indication if you're not near the printer.

Creating Purchase Orders -- While the settings in this section aren't strictly printing options, they are only used when creating and printing purchase orders so they were placed here for convenience.

P.O. # format -- This setting lets you format your purchase order numbers by including any text/digits along with any of several numbers representing date, time, or record numbers. Since you want each purchase order to be unique, it's important that the format include at least the record number (even including the time to the second doesn't guarantee unique numbers if you create orders for more than one vendor at a time). All of the same formatting specifications apply to the P.O. # as apply to receipt numbers and confirmation number formatting ([Maintenance](#) / [Program Options](#) / [Formats](#)), so refer to that section for details.

Use an Inventory Item's code for vendor's stock # by default -- Each inventory item in the database has a field for a vendor's stock number. To avoid redundancy and save time, you can leave that field blank in the inventory data if the item's code (e.g. a UPC scan code) is sufficient for the vendor, and check this option to use that on purchase orders.

Use an Inventory Item's description for vendor's description by default -- As with the stock # above, checking this option allows you to skip the vendor description entry for every inventory item, if the vendor doesn't require specific descriptions different from your item description.

P.O.S. Data Fields

To simplify data entry, as well as save database space, you might want to disable any data fields that you don't plan to use. This section briefly describes some of the fields in the P.O.S. system that can be disabled. Refer to the [Maintenance](#) / [Define Data Fields](#) section of the documentation for general information on managing data fields.

Inventory Item Fields

Qty, Re-order Threshold -- If your only purpose of setting up inventory items is to have pre-set pricing, and you don't care to manage inventory levels, then you can disable these fields.

Cost, Re-order minimum, Vendor, Vendor stock # and description -- If you don't want to print purchase orders with the software and don't care to keep track of vendor information, then you can disable these fields.

Add Tax 1 through 5 -- You only need tax fields enabled for which you have Taxes set up, so if you only have 2 different taxes then you might as well disable the other 3 fields.

Park -- This field is disabled by default, because in most cases all of your inventory is combined. However if you need to manage separate parks separately, or even separate stores in a single park, then you can enable this field to allow separate parks/stores to track their inventory levels and sales independently.

Inactive -- This field can be used to "hide" inventory items that you no longer sell (except from reports). Disable this field if that's not important.

Notes -- This can be a handy field if you like to keep a lot of information on your inventory items, but disable it if it's not necessary.

Inventory Item Discount Fields

This applies to both the General Discounts and Item-specific discounts.

Seasons/Dates Applicable -- These fields are only necessary if you have sales or other discounts based on specific dates, and want to set up discounts to automatically take effect on those dates.

Unavailable Sun - Mon -- These are only necessary if you want discounts to automatically be applied (or not applied) on certain days of the week.

Notes -- Disable if you don't need to make notes about your discount settings.

Vendor Fields

Address Line 2, Phone, E-mail -- These fields are for your own information, so disable the fields you don't want.

Tax ID, PO Notes -- These fields are used for printing purchase orders, but otherwise they are not needed.

Notes -- Disable if you don't need to keep private notes about the vendors.

Purchase Order Transaction Fields

Qty and Date Received -- If you are using the Purchase Order functions just as a convenience but don't actually track your inventory or orders outstanding with the software, then you can disable these fields.

P.O.S. Access Levels

Specific access-level permissions exist for nearly every type of P.O.S. function (inventory maintenance functions, reports, purchase orders, each kind of transaction entry, deleting/returning items, etc.) You may want to review the defaults for these and make adjustments according to how much you want each level of operator to have access to.

Each Access Level Function entry that applies specifically to the P.O.S. system will show "POS - " in front of it, for easy location. Also review the "CC Processing" functions, since those usually apply to P.O.S. functions (though they apply to reservation and customer transactions too).

For general information on changing access levels, see the [Maintenance](#) / [Park Setup](#) / [Access Levels Setup](#) section in the main documentation.

Inventory Setup

Overview

This section covers the details of setting up the inventory system in Campground Master and entering your inventory.

Note that the order of topics here reflects the typical order that these should be set up, rather than the order they appear on the menus.

Inventory Classes & Transaction Categories

There are two pick-lists that you should set up before adding your inventory items. These allow you to split up inventory reporting and accounting two separate ways. These pick lists can be configured through [Maintenance](#) / [Pick Lists](#) -- see that section for general information about editing pick lists.

Inventory Class

This pick list is used only for inventory items. It can be used to logically separate your inventory however you like, whether it's broad classes like food, supplies, etc., or very specific classes like sewer hoses, propane

accessories, and light bulbs. Classes can be selected for filtering inventory for reports or finding item details, and for grouping sales transactions by class.

Every inventory item must have a specific class assigned. So even if you have no need for detailed reporting, you should have a few broad classes that you can assign to your items.

Transaction Category

This pick list is shared with the rest of the system, so it also includes entries for all of your other charges like daily rent, extra people, taxes, etc. Every inventory item must also be assigned to a specific transaction category, so that when an item is sold, it knows what category to credit that too (similar to general ledger entries).

This is often a more broad categorization than Inventory Class, simply because it's a shared list. You might not want 200 different transaction categories for inventory items to overshadow the few needed for your reservation charges, especially since it would make the selection list a lot longer. In some cases, a single Transaction Category called "Merchandise" or "Gift shop" is sufficient, since additional transaction reports by Inventory Class can be done when more detail is needed. However there may be cases where you do need very detailed categories for accounting, especially if you export the data to QuickBooks and have many items/accounts for your inventory sales.

Vendors

A vendor can be set up and selected for each inventory item, just as a customer is selected for each reservation. However this is completely optional. You can skip the vendors completely, or you can just use them for occasional reference, or you can fully utilize the support for vendor purchase orders.

Vendor Setup

This function is accessed through Maintenance / P.O.S. Inventory Setup / Vendors. A list of vendors is shown, with buttons to Add, Edit, Copy, or Delete vendors. Double-clicking on a vendor in the list will also edit it.

You can also print the entire list, or print a Form for any vendors selected, by clicking the Print List or Print a Form button. If the Print a Form button is clicked, the Select Form dialog will allow you to choose which form to print for each selected vendor (assuming any Forms are defined with Vendors as the base table).

Edit Vendor

The Edit Vendor dialog for adding and editing vendors is nearly identical to the Edit Customer dialog, but vendors don't have as much detailed information. Likewise, the dialog for Find Vendors is basically the same as Find Customers. In addition, there is a button on the Edit Inventory dialog to add new vendors.

This dialog has the standard Previous and Next buttons, Add New, Delete, Find, and Print buttons at the top just like the dialogs for Customer Details, Reservation Details, and Site Details.

You can print an entire vendor record or a vendor envelope or other form with the Print button. This opens the Form Selection dialog, which gives you the option to print a grid or a form. The grid format prints a simple table with each field name and value. You can also choose to print any Form defined for this type of record, which allows you to easily access any custom form you've created for vendors.

Vendor Fields

Only a couple unique fields need to be covered here -- see the Edit Customer and Find Customer sections of the main documentation for general information on operating these dialogs.

Tax ID -- This field is for your reference only. This is generally the tax ID given to you by the vendor, and can be recorded here for reporting purposes when printing a vendor list.

Purchase order notes -- This field is only used when printing purchase orders. Any reference information you need to include on your purchase orders when ordering from this vendor can be entered here. While this information is entered separately for each vendor, it's common to include a standard set of information here also. This might include notes about shipping preferences, billing contact person and billing address, etc. It's recommended that you use the "..." button to open the multiple-line editing window, so you can format the information the way you want it to appear on your purchase orders.

Avoid Duplicate Vendor Names

Every vendor should have a different Company Name, since that's how they're identified for inventory items. If you happen to have two vendors with the same company name, figure out something to put in the Company Name field of one of them to make it different (e.g. just "Inc" instead of "Inc." with a period).

Item Discounts

Overview

Note: Some of the information here may seem to be presented too soon, since it appears before the Inventory Item details. It's presented first because it's important to understand discounts before editing inventory records, and because you may want to set up some general discounts before adding your inventory, so you can apply the discounts to the inventory as you add it.

Automatic Price Discounts

The convenience of a P.O.S. system often depends on how quickly and automatically it handles ringing up prices at the check-out counter, and that includes handling sale prices and discounts without special attention by the clerk. While it may not be possible to handle every situation automatically, Campground Master has a very flexible system for automatic discounts for inventory items.

Some of the situations that can be handled with automatic discounts are:

- Fixed-amount off per item (e.g. \$1.00 off)
- Percentage off (e.g. 10% off)
- Percentage off after a fixed amount off (e.g. \$1.00 off plus an additional 10% off)
- Items discounted only certain days of the week
- Items discounted only on certain dates (e.g. holidays, promotional periods)
- Items discounted based on quantity purchased (with any number of different quantity brackets)
- Items discounted based on the customer's membership or discount category (e.g. club members, seniors)
- Surcharges or separate charges per item, such as bottle deposits

Discounts are set up similar to Rates, such that you define a set of "applies if" conditions and the discount will be automatically used when a purchase is made that meet those conditions.

General vs. Item-Specific Discounts

Every single item in inventory can have different discounts applied as needed -- these are called "Item-specific discounts". This allows the most flexibility, but of course it could involve a lot of work if it required a change to every individual item when you wanted to have a general sale on every item in the store. Therefore there are also "general discounts", which can be used to change discounts for multiple items at once. You still need to add a general discount to each item that it applies to, but the advantage is that when the general discount is changed (e.g. the sale is canceled or the conditions change), you only need to change the single discount definition and it immediately affects all items.

General discounts are especially useful if you have periodic discounts on groups of items -- for instance an end-of-season 20% off sale. After adding the general discount, perhaps called "End-of-season sale", you would edit each inventory item that it will apply to and add that discount to its list. Presumably that discount will only apply for certain dates. So at the end of next season, all you have to do is adjust the dates for the general discount. You could even change the percentage if you decide to make it 25% off, for instance.

Likewise, you might have a senior discount that applies to some or all items. Maybe that discount is currently 10%, but you want to be able to change it or even cancel it later. Just make a "Seniors" general discount and add it to each applicable inventory item. Then if you need to change it, you only have to do it in one place.

Item-specific discounts would be used for things that can't be generalized, like a specific sale price for an item, or buy 3 get one free (because the amount of the discount would be specific to each item). They can also be used in situations that seem like they could be a general discount (like 10% off), but perhaps you're likely to change the amount of the discount for particular items and don't want to affect them all at once. (Even in this case, if any changes are likely to affect an entire group of items then you could set up multiple general discounts and apply them to items of the appropriate group.)

Multiple Discounts

When an inventory item has multiple discounts selected, there are certain rules for how they are applied:

Item-specific discounts are checked first -- if any item-specific discounts apply, then no general discounts are applied. The item-specific discounts are assumed to override any general discounts. (Thus a 30%-off special item-specific discount will override a 20%-off end-of-season sale.)

Only the first applicable discount found will be used -- multiple discounts will never be applied to a single item. If there are multiple general discounts selected for an item, for instance, it won't use all of them even if more than one could apply. Therefore it's important to arrange them in an order that puts the priority ("better") discounts before "default" discounts (e.g. special season sales should appear before senior discounts, unless the senior discount is better). In addition, it's important to properly qualify discounts using the "Applies if" conditions.

Surcharge exception: Any discounts marked as Surcharges will be added separately from the other discounts -- therefore it's possible to have both a Surcharge and a Discount apply to an item at the same time. (Normally only one Item Discount can apply during a given sale as explained above, but the Surcharge is a special case.) It's limited to one surcharge and one discount, however.

Important: The order in each item's list of applicable discounts is what counts, and they can be rearranged as needed for each item. In particular, remember that the order in which general discounts are listed in the Setup General Discounts dialog does **not** affect the order they are applied to each item.

General Discounts Setup

Setting up general discounts by opening the Setup General Item Discounts dialog ([Maintenance / P.O.S Inventory Setup / General Item Discounts](#)). This will list any general discounts already defined (if there are any). From here you will add or edit discounts and move discounts in the list as needed. Moving rates in the list is important because the order that they appear here will be the same order they appear when they are selected when entering transactions. Therefore you may want to put them in a logical order, or at least put the most-used rates at the top. The order is also very important if automatic rates calculation is used.

The basic procedure for defining a discounts is to click [Add discount definition](#), and then enter the details of the discount definition. You can edit any of the existing discounts by clicking on the rate in the list and selecting [Edit discount definition](#), or you can simply double-click on the discount in the list.

Warning -- Once a discount is edited or deleted, there is no way to Cancel the operation -- the changes are permanent once you leave the Edit Discount dialog and come back to the Setup General Discounts dialog. (Moving discounts is also "permanent" since there is no Cancel button, but you can always move them back.)

You can [Move](#), [Delete](#), or [Copy](#) one or more discounts by selecting the discounts in the list (Ctrl-click or Shift-click will select multiple discounts), and then click the appropriate button. Copying discounts is very handy if you have a large group of discounts and need to add a similar group of discounts have slight variations, such as percentages or season dates.

Remember that the order general discounts are listed here does **not** affect the order they are applied to items. The order does affect the order they will appear in the "Select Discounts" list when editing items -- and thus the default order they would be added if multiple items are selected at once -- but they can be rearranged for each item once selected, so the order here is irrelevant.

If you have special discounts for certain days, then the functions to [Add](#) and [Remove](#) dates from selected discount(s) makes it easy to add sale dates to the "Special dates applicable" for multiple discounts at once, or add it to the "Special dates not applicable" (which removes it from the discount) for other discounts. These functions open a dialog where you can enter as many dates as needed, separated by commas.

Editing Discounts

When you select [Add](#) or [Edit](#) from [Setup General Item Discounts](#), the Edit Discount Definition dialog will appear. This is where you define all of the details of the discount.

This dialog is also used for item-specific discounts, when [Add New Discount](#) is selected from an Edit Inventory Item dialog.

The fields are described in detail below. All discounts must have a description and either a percentage or an amount -- the rest of the fields are optional, and define when and how the rate is applied.

Description

This is important, since this will be shown on the receipts as the description for the discount. It should be kept appropriately short, especially if you're using a 3" receipt printer. Also note that the description for the item being discounted will be added in front of this description (for instance, if the description is "10% off", the receipt will show something like "Firewood : 10% off"). So keep it short!

This description is also what's shown in the selection list when using Select Discounts in the Edit Inventory Item dialog. While there's no restriction against duplicate descriptions, it would make it very difficult to select the appropriate discount when editing inventory items if there are any duplicate descriptions. If this is difficult to do while keeping them short, consider adding details widely separated from what the customer sees, like "10% off.....(end of season)". You will be able to see the details in the list, but if printed on a 40-column printer the details of the description will be cut off and not shown.

Discount each item a fixed amount

Enter a value here if you want a particular dollar amount subtracted from the price of each item. This fixed amount will be multiplied by the quantity of items as needed. You don't need to enter a dollar sign, just the number

...and/or discount by a percentage

Enter a percentage here (with or without the % symbol) to discount the items. This percentage is applied to the total price of the items, after they are multiplied by any quantity (and after any fixed-amount discount is applied if entered above).

Treat as a Surcharge (add a Charge, not a Discount)

When this box is checked, this "Discount" definition will be added as a Charge, rather than as a Discount. This can be used for instance to add Bottle Deposit amounts to soft drink sales. Enter the amount as a positive number as with a Discount, but instead of subtracting the amount, it will add it (since it's a Charge, of course).

Note: Any items marked as Surcharges will be added separately from Discounts -- therefore it's possible to have one Surcharge and one Discount apply to an item at the same time. (Normally only one Item Discount can apply during a given sale, but the Surcharge is a special case.)

Non-Taxable

If this discount/surcharge should *not* be taxed (i.e. don't adjust the taxable amount by the discount or surcharge amount), then check this box. This is typically used for bottle deposits, for instance, since those are usually not taxed.

Applies if Qty >=

If this discount should only apply if the quantity purchased is greater than 1, then enter the appropriate number here (e.g. if the discount starts if they buy 3, enter 3 here). Note that the discount will be applied to the total quantity purchased, not just those above the value here (e.g. it would be applied to all 3 items, not just those beyond 3).

Applies if Qty <=

If this discount should only apply if the quantity purchased is lower than a certain quantity, then enter the appropriate number here. This is normally only used in conjunction with the Applies if >= field for bracketed discounts, like 10% off qty 5 to 9, 15% off qty 10 or more. The 10% discount would have 9 in this field, so it won't apply if the qty is 10 or more.

Applies only in qty multiples of

If the discount should only apply in certain multiples, then enter the number here -- for instance if the discount is only to apply for groups of 5 items purchased, then enter a 5 here.

Transaction category to use for discounts

You will usually want to leave "Same as inventory item" selected, so that the discount amount is subtracted from the total sales of that category. However there may be times when you want the discounts to be reported in a completely separate category, not affecting the figures for that particular category. In that case, select the 2nd option here and then select the category you want the discount amount to be reported in.

Note however that regardless of the Transaction Category used for the discounts, the discounts will always count for the corresponding Inventory Item or Inventory Class for the item discounted. So even if you select a separate Transaction Category for the discounts (perhaps an "end-of-season" category), you can still get a report showing the actual amount received for each item or inventory class.

Also note that the Discount transaction types can be filtered when reporting, so you could get a report showing only the total discounts given for any transaction category, item, or inventory class no matter which way you choose to do it.

So, it may just be a matter of whether you want special categories for reporting particular type of discount (e.g. seniors, sales, close-outs, etc.). The other factor would be if you're exporting to QuickBooks, you need to map each category into some QuickBooks item or account. If you use special discount categories, this may not let you account for the discounts properly in QuickBooks.

Discount type to show for transaction

If this discount applies only to certain discount types, then you probably want to report these discounts according to the discount actually used by the customer. In that case, select the "Same as customer's discount" option. However if it has nothing to do with the discount types defined (e.g. just a sale price), then choose the 2nd option and select a discount to use for reporting. You'll probably want to add at least one special discount type for this, such as "Sale" or "Merchandise", that's different than any discounts that might be used for reservations.

Applies to Discounts

This function lets you select one or more discount types that this discount will apply to. For instance, if it's a senior discount, select the Senior discount type. This means that in order for this discount to apply, the Senior discount must be selected for "Discount type used" at the top of the P.O.S. sales entry dialog. You can select more than one discount type, or even all of them, and it will apply to any of the selected types.

Apply only if customer has no discounts

Check this box if this discount should only apply if no discount is selected for "Discount type used" when entering sales. While this sounds like it's not a useful option, it can be important for making discounts mutually exclusive so the proper one is used. For instance, you might have a 10% discount for seniors, 15% for employees, and 5% for anyone else (with other conditions like applying to certain dates). While the ordering of the discounts can be used make this work properly, it's a good idea to check this option for the 5% discount to make sure it's not applied to seniors or employees by mistake.

Season Dates Applicable

This field is used to specify the dates for which the discount is applicable (think of it more as "sale dates" than season dates, but "season" is used here to be consistent with Rates and Sites setup terminology). Dates in this field and the other two Special Dates fields can be entered as single dates or as date ranges. You can also enter dates without the year if you want to specify dates that apply the same to every year, but this only applies to the Season Dates, not the Special Dates. If you leave this field blank, it means that the site is available all year long (so there's no need to enter **1/1 to 12/31**).

Note that the dates in these fields will be entered in the "regional" format according to your computer's settings -- for instance, month/day for U.S., and day/month for Canadian, etc. U.S. format is used in the examples.

There is no limit to the number of dates or date ranges you can enter, and the field will scroll as needed. Separate each date range with a comma. A space after the comma is optional (it will be inserted automatically when displayed). The format of a date is fairly flexible as long as it follows the month/day/year convention. Each range should include two dates separated by the word "to". Here are some examples of valid range entries:

1/1 to 9/30, 11/1 to 12/31 (note there are no years, so it applies to every year)
1/2/2002 to 4/3/02 (years can be 2 or 4 digits)
10-5-01, 10-7-01 to 12-31-01 (single dates can be entered, and you can use the dash in a date)

Regardless of the date format you use, it will be changed to a common format (like mm/dd/yyyy) after you save the information. If you make a mistake in an entry, it will warn you when you click Save and ask you to fix it.

You can clear out old date ranges once that year has passed (and add new ones for upcoming years). Unlike the dates for Sites, there is no need to keep old dates in the lists since you won't add P.O.S. transactions for past dates.

Special Dates Applicable

Special Dates Applicable take precedence over season dates in determining if a site is available. Even if you have specific seasons, there may be times when you want to make some discounts available out of season. You could just adjust the Season Dates if you enter the dates for each year separately, but if you use the same Season Dates every year (entered without years, like **3/1 to 9/30**) then it's easier to enter any exceptions in this field.

The Special Dates Available field follows the same formatting as Season Dates, with the exception that they should always have a year in them. (Otherwise you would be better off adjusting the Season Dates.) It's OK to have dates here that are considered applicable by the season dates anyway, but it would add work for the software so it's best to avoid overlapping dates.

Note -- Since this is an *exception* list, you can't just put the normally applicable dates here -- use the Season Dates field for the normal range. The Special Dates Available list simply overrides "out of season" dates, making dates applicable that aren't in the normal season range.

Special Dates Not Applicable

This is the highest priority of the date fields. If a date is included here, the discount will be considered not applicable on this date even if the same date is in both of the Dates Applicable lists above. Dates in this list should always have years in them.

Days of the Week Applicable

These checkboxes allow you to indicate which days of the week the discount is applicable on, handy for things like a "Tuesday special". Note that the days of the week selected can be overridden by Special Dates Applicable or Special Dates Not Applicable, so take care in specifying special dates in these cases.

If you don't plan to have discounts that are based on the day of the week, then you should disable these fields (see *Define Data Fields*). This will improve the speed of the program.

Notes

The Notes field is just for your own notes, perhaps an explanation of why a discount is set up the way it is. The Notes are never seen by the customer. They can be any length (it will scroll as needed).

Adding and Editing Inventory Items

The function for adding, editing, or viewing inventory details is accessed through Maintenance / P.O.S. Inventory Setup / Inventory Items (assuming you are authorized for the P.O.S. option).

Inventory Items Setup

The Inventory Items Setup dialog lists all current inventory items, with buttons to Add, Insert, Edit, Copy, or Delete items. Double-clicking on an item in the list will also edit it.

Inactive items will show "(INACTIVE)" next to the Inventory code in the list. To make an item active again (or to set one inactive), Edit the Inventory Item and check the "Item is Inactive" box accordingly.

You can also Move items up or down in the list -- this is primarily just for your convenience, to group similar items together.

You can also print the entire list, or print a Form for any items selected, by clicking the Print List or Print a Form button. If the Print a Form button is clicked, the Select Form dialog will allow you to choose which form to print for each selected item (assuming any Forms are defined with Inventory Items as the base table).

Add/Remove General Discounts -- These buttons let you select any number of inventory items and add a General Discount to all of them or remove a General Discount from all of them, in one step. This is handy for when you have a new discount or sale situation that applies to many or all items.

Edit Inventory Item

The Edit Inventory Item dialog is used for editing single items, but also has the standard Previous and Next buttons, Add New, Delete, Find, and Print buttons at the top just like the dialogs for Customer Details, Reservation Details, and Site Details (see one of those sections for details on how these functions work).

If there are no inventory item records yet, or if you click Add New, the Record ID will show <NEW RECORD>. To add an item, just enter the information needed into this new record. (Be careful -- if it actually shows a number for Record ID, you're editing an existing inventory record!)

When you're finished with an item's information, you can click Save, which will save the changes and close the dialog -- or you can immediately click Add New to add another record so items can be entered one after another. Each time you click Add New, the current item information will be saved, a new record will be created and the cursor will immediately jump to the Inventory code field to help speed entry. Another time-saver is to use **Alt-A** on the keyboard instead of using the mouse to click Add New.

To further speed item entry, certain fields will be automatically set to the values used in the last item. These fields are Inventory Class, Transaction Category, and any Tax selections. Therefore it's a good idea to add your inventory in batches of similar items, so you don't have to change these fields often.

Another helpful feature is the Add Dup button. This adds a new record with exactly the same information as the current one (and jumps to the new record so you're editing that one, not the original one). This helps when you're entering many similar items, for instance different kinds of soft drinks. Often the only changes you need to make between them are the inventory code (especially if using the bar code), description, and quantity on hand. Vendor stock # or description might also need to be changed if you're not letting those default (leaving them blank -- see below).

If you decide not to save the changes or new record, even after entering some information, click the Cancel button. You will be warned if any new information would be lost by canceling the changes to the record, at which point you can abort the Cancel and get back to the dialog without losing your changes.

There is no limit to the number of items you can enter (except in demo mode), except computer memory (10000 or more is generally not a problem).

The fields are described in detail below. All discounts must have a description and either a percentage or an amount -- the rest of the fields are optional, and define when and how the rate is applied.

Inventory Code

If you're using a bar-code scanner, this should be the bar code as scanned from the product (you can use the scanner to read the bar code right into this field). Otherwise it can be any name or code you want to use for the item. While it's possible to leave this field blank, it's not recommended since some reports show items using this field. Having one or more items with blank codes will make reports confusing.

Tip: When an item scan code or text is entered on the P.O.S. sales entry dialog, it will look for an exact match with this field first -- if one and only one exact match is found, then that item will be immediately added to the ticket. So if you're not using bar codes for everything, then using short unique codes like "fw" for firewood can speed sales entry for common items.

If more than one exact match is found, then it will show those items in a list for you to select from (for instance you could use the code "soda" for all of your soda items). If no exact match is found, then it looks through all items looking for a partial match with either the inventory code or description fields, and will show all partial matches in a list to choose from. If only one partial match is found, and if the Program Option is set to auto-add a single partial match, it will be used automatically. Otherwise, if any partial matches are found they will be listed for you to select one.

More... codes

If you want to have more than one code match a single item, e.g. to have all types of candy bars ring up as a single "candy bar" item, then click the "More..." button next to the code entry field. You can scan or enter any number of codes (or put any number of searchable words). Just make sure each one is on a separate line. A match on any one of these when making a sale will work the same as a match on the primary Inventory Code. However all reporting will be done using only the main Inventory Code -- there will not be a record of which code was actually scanned or entered for the item.

Description

This description is exactly what will be shown on receipts for the item, so it should be descriptive enough for the customer. It should also be short enough for the printer, so if you're using a 3" receipt printer (normally 40 columns), keep it short enough to fit on one line. If you're using a pole display, it should be limited to 20 characters (or at least make the first 20 characters reasonably descriptive). Also keep in mind that if discounts might apply then you should leave room for the discount's description. Receipts will show discounts with this description followed by the discount description, like "20 oz. soda : 10% off" (where the discount description is "10% off").

Inventory Class

Every item must be assigned to an inventory class. Depending on how detailed you want your reporting, you might have 2 classes or 100 classes, or more. This is completely up to you. Just click on the drop-down list and select the appropriate class. For convenience, you can click the Edit button next to the drop-down list to open the entire pick-list of classes for editing or adding new ones. For more information about setting these up, see the inventory setup section [Inventory Classes & Transaction Categories](#).

Transaction Category

As with Inventory Class, each item must have a transaction category assigned, which will be used for each sale (charge) transaction for this item. See above for details.

Park (location)

This field will only appear only if you have more than one Park record defined. If you don't separate your inventory between parks (e.g. keep track of qty on hand separately for each location), leave this field blank.

Otherwise, select the park where this inventory item is located. If you have the same items at multiple parks, then the inventory items will have to be duplicated for each park, with the appropriate park selected and quantity on hand entered for each location. Also note that you will need to set up a filter under [Filter inventory sales lookup](#) at each workstation depending on its location, so that the proper inventory record is used and updated as sales are entered.

Vendor

If you want to keep track of the vendor for each item (or the preferred vendor, if several), then select that vendor here. Of course this is mostly important if you'll be printing purchase orders with the program, but you might want to just keep this information for your reference also. You can add a new vendor easily with the [New Vendor](#) button, without leaving the item you're working on. Note that it's important that each vendor have a different name, so that they can be identified in this list and assigned properly.

Vendor's Stock # and Description

These are only necessary if you're printing purchase orders. Even so, if the item's inventory code can be used for the vendor's stock #, and/or the item's description can be used for the vendor's description, then you can leave one or both of these fields blank. In that case, you must also make sure that the corresponding options in [Maintenance](#) / [Printing Options](#) / [Purchase Orders](#) are also enabled. If the vendor for this particular item wants a specific stock # or description, then you need to enter them here.

Cost each

This is helpful if you're printing purchase orders (so you don't have to enter it into the order each time), or you can enter it just for your reference. This can also be used for various reporting, such as On Hand and Cost of Goods Sold, but depending on the COGS calculation method it won't necessarily be the cost used in the reporting -- only as the "current" unit cost for entering new purchases.

Re-order threshold

This value can be used to warn you when stock is getting low, if the warning is enabled ([Maintenance / Program Options / P.O.S.](#)). It's also used for reporting ([P.O.S. / Inventory Reports / Items below re-order threshold](#)), and for automatically selecting items when creating purchase orders ([P.O.S. / Purchase Orders / Create Purchase Orders](#)).

Re-order minimum qty

This value is only used for the default order quantity when creating purchase orders ([P.O.S. / Purchase Orders / Create Purchase Orders](#)). Otherwise it can be left blank or just entered for reference.

Quantity on hand

This is the current quantity in stock, and should be entered for any item for which you wish to track the inventory level (leave blank for no tracking). It will be automatically updated each time a sale (or return) is made, and can be updated through purchase order receiving. If you want to change the Qty on hand shown, you can use the "[Adjust...](#)" button next to the quantity and enter the number added (or new qty on hand). This will use the Enter Adjustment function for entry of the details.

If you don't want to track inventory for an item (and don't want any warnings that it's out of inventory), leave this field blank. **Don't enter 0** -- that would actually indicate none in stock, not that you don't want to track it. Once you enter a number, you can't clear it to stop tracking unless you go through [Raw Data Tables](#).

Note that the quantity doesn't have to be a whole number. For instance you can track gasoline, propane, yards of rope or whatever you need to in decimal-point quantities like 1.5 or 0.03. Likewise, the price will be multiplied appropriately with whatever quantity you enter on the P.O.S. sales entry dialog, and inventory updated accordingly.

If you previously had a quantity entered, even if 0, and you want to change it back to blank so there's no tracking, then the only way to do this is through the [Raw Data Tables](#).

Price Each

This must be entered for every inventory item (unless Ask is checked -- see below). This should be the pre-tax price for a single item (Quantity 1), before any discounts. The dollar sign (or other currency symbol) does not have to be entered, just enter a number like 5 or 1.95. Prices must be entered with the decimal point if not whole dollars -- it does not assume 2 decimal places (e.g. \$5.00 is entered as 5, not 500).

Ask for price

If you check the "Ask" box next to Price Each, a small dialog for entering a price will appear when this item is selected when entering sales. This would typically be for bulk-type items like gasoline, propane, or miscellaneous fees -- you can either interpret it as a total price (e.g. assume the Qty is 1) or a per-item price (e.g. assume they might have a multiple qty of an item that can vary in price).

If you check this box and also enter a Price Each value, then the Price Each will be used as a default. The clerk can leave it at that price or change it. If there is no "typical" price, then leave Price Each blank.

Ask for Qty each sale

If this option is checked, it will always pop up a window to ask for the quantity sold, immediately after scanning or selecting an item. This eliminates the need to enter the Quantity before scanning the item, but also means an extra step (at least clicking OK or pressing Enter) for each one. So it's recommended only for items that are usually sold in quantities other than 1 (e.g. a measured item like propane).

Applicable Taxes

Check the box for any taxes that normally apply to this item when it's sold. The total price with tax (for a single item) will be shown below. Of course tax is actually calculated after all items on a ticket are added up, rounding appropriately on the total rather than adding tax to each item at once.

Note that there is also an option to sell items as Non-taxable (e.g. for tax exempt customers), in which case the tax selections here would be ignored.

General Discount Pricing Schedules Applicable

To select one or more applicable general discounts, click the Select Discounts button. A list will appear with all general discounts shown. Use Ctrl-click to select one or more discount that should apply to this item. Once selected, you can change their order with Move Up and Move Down. Remember that the discounts will be applied in the order they appear here, so the order can be important if the discounts aren't defined to be mutually exclusive. See the Item Discounts section for details on how discounts work.

Item-specific Discount Pricing Schedules

Item-specific discounts must be set up separately for each item that requires them (thus it's best to use general discounts whenever possible). These are added, edited, and deleted right from this dialog -- they don't appear anywhere else. If this inventory item is deleted, its item-specific discounts are deleted with it. If it's duplicated using Add Dup, its discounts are duplicated as also (items never share item-specific discount records).

If more than one discount is shown, you can change their order with Move Up and Move Down. Remember that the discounts will be applied in the order they appear here, so the order can be important if the discounts aren't defined to be mutually exclusive. Also remember that any item-specific discounts that apply will override any general discounts. See the Item Discounts section for details on how discounts work.

Inactive

It's never a good idea to actually delete an inventory item once it has been used in a transaction (at least until all such transactions have been purged), because that would break the link with the transaction and affect reporting. If you no longer stock an item, simply check the Inactive box. That will keep it from being brought up for a sale, and will hide it from most reports unless specifically filtered to include inactive items.

Notes

You can enter any notes you like here, just for your records. Customers and vendors will never see these notes, but you may find them useful for recording historical information, notes about ordering from certain vendors, etc. To enter more than one line, click the "..." button to open a multi-line editing window.

Journal...

In addition to the single-entry Notes field, you can add any number of Journal entries to an item, which are date/time/operator tagged. This can be used any way you like, for instance to track price changes for an item, or make notes as to why certain changes were made to it. This button opens a list of existing entries and also the adding/editing functions.

Audit Trail...

This button opens the Audit Trail for this particular item, showing a list of all changes made to it (at least as far back as when version 6.0 was installed, since the Audit Trail function did not exist before then). Note that all inventory quantity changes resulting from sales are also recorded, so this could be quite long for popular items.

Importing Inventory and Vendor Data

The Import function can be found on through: [File / Import / Import Inventory/Vendor data](#). You must have Administrator access to use this function.

IMPORTANT: Importing cannot be undone -- make sure you have a backup before doing the import, so you don't have to manually delete data if a mistake is made!

There are two primary requirements for the data to be imported:

1. It must be in either a comma-separated-value (CSV) or tab-delimited (text) format. If it's a CSV format, make sure that any fields with commas are enclosed in quotes (this is the standard).
2. The fields must be in a form that equates to the fields in Campground Master. For instance, the Contact name for vendor information must be a combined first/last name, City/State/Zip must be separated, Inventory Item Classes must match the classes you've defined in the pick lists, Taxes to be applied must be as a yes/no or true/false field for each tax rate, etc.

Importing Vendors vs. Inventory

Keep in mind that vendors and inventory items are separate records in Campground Master. Inventory Items are "linked" to vendors, but the vendor data is in a separate table.

You can import just the vendor data from a vendor list, or you can import the vendors along with inventory items at the same time if your import file contains the necessary information. You will see when defining the import fields (below) that there are two sets of fields -- one for Vendors and one for Inventory Items. If you're importing just the vendor data, then you will only select fields for vendors. If the import data has inventory information, then you can also import the inventory items by selecting those fields. If you have two separate lists, one with vendors and one with inventory, import the vendors first. Then import the inventory, and if the inventory information has a vendor's company name as one of the fields then it can be properly linked to the vendors already imported.

Importing Vendors from QuickBooks

You can import a vendor database from QuickBooks accounting software using this same Import function. First you need to export the data from QuickBooks using its Export function. In QuickBooks, select from the menu: File -> Utilities -> Export... an Export dialog will open where you select the lists to be exported. Export the Vendor list only.

Then click OK and enter a file name to export to, such as "Vendors.txt". This will be a tab-delimited file that can be used for importing below, and will have appropriate address/city/state/zip information if you entered this data uniformly into QuickBooks. Note that the exported table may also have some extra information in front, like "CUSTDICT" records. Just select those and delete them before importing the vendor data.

Importing Inventory from QuickBooks

You can also import inventory from QuickBooks if you have it set up as "Items". First you need to export the data from QuickBooks using its Export function. In QuickBooks, select from the menu: File -> Utilities -> Export... an Export dialog will open where you select the lists to be exported. Export the Item list only.

Then click OK and enter a file name to export to, such as "Items.txt". This will be a tab-delimited file that can be used for importing below, and will have item information. Note that the exported table may also have some extra information in front, like "CUSTITEMDICT" records. Just select those and delete them before importing the vendor data.

The Import Process

There are several easy steps to importing.

- 1. Select a file.** You can enter the entire path to the import file, or use the Browse button. When browsing, it will look for .csv and .txt files by default, but you can change the file type to show all files if needed. For instance, QuickBooks exports files with the ".iif" extension, so you need to select All Files to see those.
- 2. Select the file format.** Select either comma-separated or tab-delimited. Don't worry if you get it wrong -- the data will obviously look wrong when you import it if you choose the wrong type, and you can simply change this selection and do the Load Import File again.
- 3. Load the file for preview.** Click the Load Import File button to read the data. The data is not actually added to your database yet, it's just loaded in the list on the dialog for previewing and editing.

4. Define fields to import. If the file loaded successfully you should see the data in nice columns in the table. If the import file had headers in it, you'll even see the headers in the first line, like "first name", "last name", "city", etc. Now comes the important part -- you have to decide what each column means, in terms of Campground Master fields. This is usually pretty easy to do. Just right-click on each field (either the header or the actual data), and then select the field that corresponds to that column. Customer, Reservation and Transaction fields are listed separately, and there is also a separate list for Site Preferences (primarily used for preferences that might affect the charges, like 50A service). The column header will then change to that name so you know you've defined it. You don't have to assign fields to each column -- just skip any that you don't need or don't have corresponding fields. If you make a mistake, use the Remove function on the right-click menu. See the notes below for more details.

5. Select vendor fields to use for duplicate-removal besides the company. When vendor data is imported, duplicate vendors will be automatically removed if possible. This not only applies to data you're importing, but also to any vendors already in your database (it won't remove duplicates from your database, but it will avoid importing new duplicates.) This requires at least a Company name field (the data isn't much use without that anyway). You can also choose to check the Zip code field and/or the Address line 1 fields, to avoid filtering out duplicate vendor names unless they have the same address. If you uncheck these fields, or if they're not available in the imported data, then it will assume any that match first and last names are duplicates. Note however that this is only offered as a convenience when importing. Once the vendors are imported, you should make sure that there are no duplicate company names in the database. See the section on Vendors for details.

6. Convert vendor names/addresses to mixed case or upper case. Other programs may force or suggest that vendor information be all upper case, which is easier to enter but is not as professional looking on orders. So you may want to decide to start entering the information in mixed-case, and you can also have the import function convert the old information. Conversely, you can make sure that all of the old information is in upper case if you wish to keep with that procedure. Note that this only affects the data during this session, not data already entered or previously imported into Campground Master.

7. Edit data if needed. The preview list is fully editable, so you can delete any records that you don't want to import (like obvious duplicates or blank records), and you can even enter corrections as needed here before importing. Just click on a field in the grid to select it and then start typing to replace it, or click twice to edit the value without replacing it. Likewise, just click any field and click the Delete button to delete the entire row. (Ctrl-click and shift-click functions for multiple selection also works.) Note that if the import file included a header row, you should also delete that row.

8. Import the data. When everything looks right, click the Import Data! button to perform the import. You may see an error or warning prompt about duplicate filtering or field definitions if there seems to be something missing. As the data is imported, you will see customer/reservation totals and a duplicate total count up at the bottom.

When the import is complete, all records imported are removed from the list, but there may be some records left over in the list, with a message saying that some errors were detected. To see why a record was not imported, just hold the mouse over the record in the list -- an error message will be shown with the reason for the error. Errors are typically a result of records that don't have an Item code or Company name (required by Campground Master), or for Inventory Item Classes or Transaction Categories that weren't recognized, or fields that were not formatted properly. You can ignore them and close the dialog to skip importing those items, or you can manually edit the records and run the Import again, as many times as needed to get them all imported.

When all is finished, just Close the dialog -- the data is imported to the database and the reports will be refreshed if necessary.

Notes on Importing Data

Some fields can be selected more than once, and the data will be combined into the one field in Campground Master. For instance, any data that doesn't have a direct import field correlation can be imported to the

Inventory or Vendor Notes field. Each imported field will be added to a new line in the Notes, so that information is transferred even if Campground Master doesn't have a specific field for it. Also, any number of columns can be assigned to Vendor Contact Names, and they will simply be combined into the single field.

The Add Tax fields (flags for whether each tax should be added) and the Inactive field are true/false fields. These must be one of the following: true, false, yes, no, T, F, Y, or N. (Upper or lower case does not matter). If it's blank, then it's assumed False. Note that the Add Tax fields are simply numbered 1 to 5. You will need to know which number applies to each of your tax categories -- see Maintenance / Park Setup / Taxes for this numbering.

Inventory Item Class and Transaction Category

Inventory Item Classes and Transaction Categories must be assigned to every inventory item in Campground Master. When importing, you must either select an import field for each of these, or assign a default class/category to every imported item (you will be prompted for this when you do the import). If the import file has no field that would correspond to these, then the default is the only possibility.

However if the imported data does have some kind of class and/or category information, then it would be a good idea to keep that. The difficult part is that an exact match must be found for the class and/or category in the corresponding pick list, or else it can't be imported. Since there are often a large number of classes given to items, it would be a lot of work to enter all of those manually into Campground Master. So here is a procedure which can help:

1. Load the import data into this Import dialog.
2. Locate the data column that appears to be the class information, and Copy/Paste that whole column into an Excel spreadsheet (or any spreadsheet program).
3. Sort the column (if you didn't already do this before copying).
4. Go through and delete any duplicates and any other unwanted information (like headers), and note how many there are.
5. In Campground Master, close the Import dialog and open the appropriate Pick List, like Inventory Item Classes.
6. Click New Record as many times as needed to add all of them.
7. Copy the column of data from Excel, and Paste it into each of the first 3 columns in Campground Master (starting at the first pick list item, of course)
8. Now go back to Import, and you can import the data. (Select the appropriate field for each column in the import list of course.)

Repeat steps 2 through 7 for both categories and classes, if needed. Note however that it would probably be better to just do the classes and let the categories default to a single value. See the section on [Inventory Classes and Transaction Categories](#) for more explanation of these fields.

Filter inventory sales lookup

This function, under Maintenance / P.O.S. Inventory Setup, lets you set up a filter defining which inventory items will be available for sales entry (Point of Sale).

This is most often used when you need to track inventory separately for multiple parks or stores. For each workstation in the multi-park or multi-store network, you would set this filter to include only those inventory items designated for that park record. (Note that if an item's Park field is blank, it will still be available to all parks).

It could also be used to limit sales to inventory items of a particular cost (e.g. to exclude high-ticket items), or to restrict certain items like liquor at certain check-outs.

If you find that some things you know are in inventory can't be found when entering sales, try opening this filter and clicking [Reset Filtering \(include all\)](#) to make sure it's not filtering out something by mistake.

Index

- 3 -

3" Receipt Printer
Setup 377, 379

- A -

A/R Adjusted
Entering Adjustment Transactions 411
Transaction Type 121

Access levels
POS 577
Setup 21, 324

Accounts Receivable 59
Balance Adjustment 411
How the A/R Balance Works 120
Starting Balance 24

Actions
On Events 506

Add Hotspot Dialog 332

Add Site Indicator Dialog 332

Add/Insert Multiple Sites 279, 281

Adder mapping 216

Adding Customers 112

Adding Reservations 66

Adding Transactions 120

Additional Notes Setup 277

Add-on Rates 292

Adjustment Detail report 557

Adjustment Filter 557

Adjustment Summary report 558

Adjustments (Inventory) 565

Administrative Functions 272

Advance Next Reservation 95

Advanced Customizations 421

Advanced Site Filter 31

Alerts 181
Alert dialog 181
Deleting 182
Dismissing 181, 182
Hercules 2-way errors 225
Options 182
Processing 181, 182

View Alerts 182

Allocating Payments to Categories 128, 137

Alt-keys 11

Amp Service values mapping 214

Annual Reservations 91

Applying Deposits 121, 137

Arrival (Check In) time 277

Arrivals (Tab View) 49

Arrivals Statistics Report 167

Assign a new site 95

Audit Trail 181, 186
Filtering 187
Options 187
Viewing 186

Authorization Code 20, 29, 277

Auto check-out 49

Auto-backup location 369

Auto-checkout 77

Auto-Rates 132, 301
Examples 305
Options 365
proper order 303
Setup 301
Troubleshooting 301

Availability Report 167

Average Cost 565

- B -

Back Up Database 15, 272, 274, 414

Back-Dating Transactions 151

Background Tasks 182

Backup location (secondary) 369

Bad Links 413

Balance Charges & Payments 59

Bar code scanning 542

Batch checkout 77

Batch E-mailing 177

Batch E-mailing options 402

Batch-printing receipts & invoices 179

Bitmap files for maps 326

Black & White Printing 27

Black-listed Customers 118

Block Previous Reservation 95

BMP files for maps 326

Bottle Deposits 581

Bounced checks 151

Bulk Check-out 49

- C -

- Campground Setup 15
- Cancel a reservation 96
- Cancel Reason 96
 - Default 364
 - Pick List 345
- Canceling Hercules Reservations 222
- Cancelled reservations 51
- Can't Book 67
- Caption / Title Bar 8
- Cash Drawer
 - Opening 128
 - Setup 380
- Cash register window 542
- Cash-out report (Receipts by Payment Method) 59
- Categories - Transactions (Pick List) 345
- Cayan Genius 390
- Cayan Merchantware 390
- Change Due
 - Rounded 357
- Change Sites 95
- Changing Master computers 528
- Changing Reservation Dates 95
- Changing Shifts 405
- Changing the customer for a reservation 90
- Charges
 - Entering Transactions 134
 - Transaction Type 121
- Charges by Category 59
- Check for Updates 275
- Check In/Check Out times (setting) 277
- Check in/out times for Sites 281
- Checking In 76
- Checking Out 77
- Checking out, Bulk 49
- Cleaning out old data 406
- Clerks 7
 - Changing password 7
 - Logging in or out 7
 - Setup Operators 321
- Color Keys 28
- Color Schemes 444
 - Context 444
 - Default 447
 - Rules 444
 - Setup 444
- Command line parameters 321, 419, 526
- Company name 108
- Confirmation E-mail 98
- Confirmation letters 98
 - Text & options settings 376
- Confirmation Number format 355
- Confirmations
 - Batch Printing 179
 - Confirming a reservation 97
 - E-mail Text 403
 - E-mailing 147, 396
 - Printing 144
 - Receipt Type 146
- Conflicting Reservations 412
- Connecting Progress Dialog 532
- Context Menus 10, 36
- Copying Data 14, 42, 193
- Copying the database to another computer 414, 417
- Copyright 2
- Cost of Goods Sold 555
- Couldn't book 51
- Counter Sales 154
- Create database 20
- Creating a database 406
- Credit Cards 98, 374, 386, 390, 392, 393, 394
 - Cayan MerchantWare 390
 - Compliance 394, 395
 - Debit Card Setup 389
 - Error - Exceeds sales cap 141
 - Genius Setup 390
 - Guarantee info 98
 - Hardware 382, 383
 - IC Verify 394
 - MCPS / T-Gate 392
 - MCPS / T-Gate Settings 392
 - MerchantWare 390
 - MerchantWare Settings 390
 - Payments 139
 - PC Charge 393
 - PC Charge Settings 393
 - PCI Compliance 394, 395
 - Processing 139
 - Processing Setup 382, 384, 394
 - Readers 382, 383
 - Receipt Settings 374
 - receipt types 146
 - Refunds 141

- Credit Cards 98, 374, 386, 390, 392, 393, 394
 - Removing 395
 - Reversal 142, 393
 - Secure Vault 98, 386, 394
 - Security 394, 395
 - Setup 394, 395
 - Signature Slips 374
 - Swipe data 394, 395
 - Update expiration 139
 - Voiding 142
 - X-Charge 386
 - XpressLink Options 386
 - Credits
 - Entering Transactions 134
 - Transaction Type 121
 - Cross-Table Queries 462
 - Axis 462
 - Custom Groups 466
 - Editing 458
 - Groupings 462
 - CSV files
 - Exporting to 42, 193
 - Importing from 189
 - Currency Format 355
 - Custom Dialogs 493
 - Custom Envelopes 467
 - Custom Event Actions 506
 - Custom Forms 467
 - Custom Labels 467
 - Custom Menus 485
 - Custom Package Importing 516
 - Custom Pick Lists 509
 - Custom Queries 448
 - Custom Receipts 467
 - Custom Reports 448
 - Custom Tab Views 54, 422
 - Queries 448
 - Custom Tables 509, 513
 - Customer
 - Changing for a reservation 90
 - Customers 114
 - Adding 112
 - Credit Cards 395
 - Customer Details Dialog 114
 - Deleting 118, 119
 - Duplicate checking 76
 - Duplicate Customer Settings 365
 - E-mailing 177
 - E-mailing a customer 114
 - Finding 116
 - Importing 29, 189
 - Merging 118
 - Notes 110
 - Reservation History 114
 - Temporary Operator Override 114
 - Transaction History 114
 - Transactions 154
 - Viewing and Editing Details 114
 - Warning flags 118
 - Working with 112
 - Customers on site 50
 - Customizations 421
- D -**
- Daily Tips 10
 - Data Field Definitions 350
 - Data Fields
 - Customizing 22
 - Defining 350
 - User-defined Tables 511
 - Data Tables 409
 - Database 272, 274, 413, 414, 417
 - Auto-backup location 369
 - Automatic Backups 15
 - Backing Up 15, 272, 414
 - Basics 15
 - Copying 275
 - Copying to another computer 414, 417
 - Data Fields 350
 - Data Tables 409
 - Default location 413
 - Exporting 42, 193
 - File location 413
 - Files 15
 - Folder 15
 - Importing 29, 189
 - Location 15
 - Maintenance 272
 - Moving to a safe location 413
 - Moving to another computer 414, 417
 - Multiple copies 419
 - Options 369
 - Organization 17
 - Park Setup 276
 - Pick Lists 345

- Database 272, 274, 413, 414, 417
 - Pseudo-fields 241
 - Purging 406
 - Renaming 275
 - Resetting 406
 - Restoring 272, 274, 275, 414, 417
 - Setup 15, 272
 - Setup Checklist 18
 - Transferring 414, 417
 - User access 15
 - Database maintenance
 - Repair <bad links> 413
 - Repair orphaned reservations 412
 - Repair orphaned transactions 411
 - Date Format 355
 - Dates
 - Entering on Dialogs 13
 - Tab View Selections 30
 - Day Fee Rates 292
 - Day Passes 94
 - Debit Cards
 - Cash Back 139
 - Options 389
 - Payment 139
 - Processing 139
 - Default Global Color Schemes 447
 - Default Site Filter 31
 - Defaults
 - Cancel type 364
 - Reservation fields 364
 - Deleting Customers 118, 119
 - Deleting Reservations 103
 - Deleting Transactions 128
 - Departure (Check Out) time 277
 - Departures (Tab View) 49
 - Departures Statistics Report 167
 - Deposit Account 59
 - Deposit Adjusted
 - Entering Adjustment Transactions 411
 - Transaction Type 121
 - Deposit Applied 124
 - Transaction Type 121
 - Deposits 124, 137, 316
 - Automatic 316
 - Automatic calculation options 362
 - Auto-Set 316
 - Balance Adjustment 411
 - Calculation Types 318
 - Calculations 319
 - Definitions 316, 319
 - Editing 319
 - Entering Transactions 137
 - Groups 137
 - Guaranteeing a Reservation 98
 - How the Deposit Balance Works 120
 - Import and Export 316
 - Setup 316, 318
 - Splitting 137
 - Starting Balance 24
 - Transaction Type 121
 - Transferring 143
 - Deposits (security) 151
 - Detail Transaction Reports 55
 - Dialog Controls 13
 - Dialogs
 - Adding fields 493
 - Custom 493
 - Edit Generic Record 512
 - Editing 495
 - Editing Elements 498
 - Element List 497
 - Setup 494
 - Direct to Port
 - Cash drawer settings 380
 - Receipt printer settings 379
 - receipt selection 146
 - Dirty flag options 357, 360
 - Dirty sites 354
 - Discounting Sales 542
 - Discounts
 - Entering Transactions 134
 - Transaction Type 121
 - Types Pick List 345
 - Discounts by Discount Used 59
 - Double-Click action 422
 - Double-click actions 357
 - Double-Click Functions 36
 - Drop-down Lists 13
 - Duplicate Customer Checking 76
 - Settings 365
- E -
- Edit Dialog Definition 495
 - Edit Dialog Element 498
 - Edit Event Action 506

- Edit Form Element 476
- Edit Generic Record dialog 512
- Edit Hotspot Dialog 332
- Edit Inventory Item 585
- Edit Menu Definition 487
- Edit Menu Item 490
- Edit Site Indicator Dialog 332
- Editing
 - User-defined Relationships 514
 - User-defined Tables 511, 512
- Editing Category Allocations 128
- Editing Customer Information 114
- Editing Dialogs 495, 498
- Editing Forms 470
- Editing Menus 487
- Editing Reservations 103
- Editing Transactions 128
- Electric deposits 151
- Electric Meters 91
 - History 175
 - Rates Setup 292, 305
 - Readings entry & report 170
 - Setup 25, 281
 - Setup Details 342
 - Wrap-around setting 277
- E-mail
 - Attaching files 401
 - Batch sending 177
 - Customer E-mail list (report) 177
 - Mass E-mailing 177
 - Reservation E-mail list (report) 177
 - Resuming a batch 177
 - Sending (Preview) 401
- E-mail confirmations 98, 103, 128, 147, 396, 403
 - iCal files 250
- E-mail forms 404
- E-mail receipts 147, 403
- E-mail Requests
 - Example Parsing Set 249
 - Retrieving 261
 - Site Data Fields 234
- E-mail Reservation Requests
 - Connections & Options 232
 - Setting Up 230
 - Site Data Fields 229
- E-mail setup 396
- E-mailing
 - batch 402
- E-mailing customers 114
- Entering Customers 112
- Entering Reservations 66
- Entering Transactions 134
- Envelopes 25, 176
 - Custom 467
- Estimated Arrival Time 67
- ETA 67
- Event Actions 506
 - Editing 506
 - Setup 506
- Event Triggers 506
- Expand Region 475
- Expand Sub-menus 489
- Expense
 - Entering Transactions 156
- Expenses
 - Transaction Type 121
- Export to Web
 - Example web form 249
 - FTP Connection 231
 - Setting Up 229
 - Site Data Fields 229, 234
- Exporting 189, 267, 270
 - CSV File 193
 - Pocket PC) 193
 - QuickBooks 194
 - Raw Data 409
 - Reports 42, 163, 193
 - Tab-delimited format 193
 - Vacancy Grid 267
 - Vacancy Grid variables 270
 - Web page Javascript example 270
 - Web page opload settings 231
 - Web pages 267
- Exporting iCal files 251
- Exporting to iCal 251
- Expressions 425, 433
 - Context 430
 - Creator dialog 432
 - Double-click actions 422
 - Elements 433
 - Entering 432, 433
 - Errors 431
 - Fields 433
 - Function Descriptions 433
 - Function Types 442
 - Functions 433

Expressions 425, 433
 Functions Reference 442
 Macros 436
 Mouse-over text 422
 Operators 425, 433
 Overview 425
 Processing 431
 Quick-Info text 422
 Scripts 438
 Syntax 425
 Testing 432
 Timing 432
 Tip Text 422
 Value types 425
 Variables 425
 Extend Previous Reservation 95

- F -

Field Definitions 350
 Field Names 350
 Filter Conditions 456
 Filter Inventory 550
 Filter Inventory sales lookup 593
 Filter Text 32
 Filtering Reservations for Reports 179
 Filtering Sites for Reports 31
 Filtering Transactions 57
 Financial Reports 59, 63
 Find Customer Dialog 116
 Find Inventory Items 549
 Find Reservation Dialog 110
 Find Text 32
 Finding a site on the rack 40
 Finding Customers 116
 Finding receipts 161
 Firewall software 539
 Fit to Page Horizontally 27
 Font settings 355
 Forgot password 7
 Format Options 355
 Formatting Grid Reports 27
 Forms 179, 469, 476
 Batch Printing 179
 Creating 467
 Editing 467, 470
 Editing Elements 476
 Element Types 476

Elements 475, 476
 E-mail 404
 Export 475
 Import 475
 Importing 469
 Levels 475
 Overview 467
 Park Form Printing 277
 Printing for Receipts 179
 Printing from Customer Details 114
 Printing from Find Customer 116
 Printing from Find Inventory Item 549
 Printing from Find Reservation 110
 Printing from Inventory Setup 585
 Printing from Reservation Details 103
 Printing from Tab Views 36
 Printing from Vendor Setup 578
 Printing Receipts 144
 Receipt Types 146
 Regions 475, 476
 Sample 469
 Selection dialog 485
 Setup 467
 Site Form Printing 279
 Tables 476
 Friend 2-way 206
 Alerts 181
 Setup 207
 FTP settings for iCal 233
 Full Network Resync 533
 Function Keys 11
 Function Options 357
 Function Reference (Expressions) 442

- G -

Gas Meters
 History 175
 Rates Setup 292, 305
 Readings entry & report 170
 Setup 25, 281
 Setup Details 342
 Wrap-around setting 277
 General Discounts 581
 General Work Orders 184
 Genius by Cayan 390
 Getting Started 5
 Getting Support 1

Global variables 425
 GMail 396
 Group name 108
 Group Reservations 66, 81, 82, 84, 86, 87, 90
 Splitting deposits 137
 Guarantee
 Credit Cards 394, 395
 Guarantee a reservation 98
 Guest reservations 67
 Guests
 Guest Management 109
 Temporary 94

- H -

Hardware

Cash drawer setup 380
 Credit card swipe 382, 383
 Pole display setup 570
 Printer setup 25
 Receipt printer setup 377, 379
 Types 569

Help

Tips 10

Hercules 206

Retrieving Requests 261
 Setting Up 2-way 207

Hercules 2-way 209

Adders 216
 Alerts 225
 Amp Service values 214
 Automatic mode 221
 Automatic processing 225
 Availability 217
 Cancellations 222
 Connections 218
 Conversion from 1-way 209
 Data fields 209
 Diagnostics 218, 224
 Discounts 217
 Duplicate customers 224
 Error handling 225
 Initial sync 219
 Manual Mode 220
 Operations 219
 Operations setup 210
 Parsing setup 212
 Refunds 222

Request full sync 224
 Reservation Handling 222
 Reservations setup 211
 Send Full Sync 224
 Setup 207
 Setup dialog 210
 Site Data Fields 213
 Site Locking 225
 Sync errors 225
 Synchronization 219, 224
 Unit Types 215
 Unlock All Sites 224
 View Diagnostics 224
 Viewing recent reservations 223

Hiding the task bar icon 29

History / Security Cleanup 395

Hourly Reservations 66, 91

Hourly Reservations Setup 23, 333

Housekeeping report 166, 354

How-Heard

Pick List 345

Reports 169

HTML

Exporting to 267

Javascript example 270

Reservation form example 271

HTML E-mail 404

- I -

iCal files

Attaching to E-mail 250

Downloading 252

Editing Profiles 254

Export settings 233

Exporting 251

FTP settings 233

Import settings 233

Importing 252

Overview 249

Parsing Sets 258

Profile Setup 253

Retrieving 252

Sample Parsing 258

Setting up for Export 251

Setting up for Import 252

Site Data Fields 234

Upload settings 233

- iCal files
 - Uploading 251
 - iCal Profiles 253
 - Icons 8
 - ICVerify Processing 394
 - Image files for maps 326
 - Import Package 516
 - Importing 29, 189
 - CSV files 189
 - Customers 189
 - Customization Packages 516
 - Online Parsing Rules 238
 - QuickBooks Customers 189
 - Reservations 189
 - Tab-delimited 189
 - Transactions 189
 - Importing from iCal 252
 - Importing iCal files 252
 - Importing Inventory 590
 - Importing Sample Forms 469
 - Importing Vendors 590
 - Income & Expenses 59
 - INI file 15, 272, 274, 414, 417, 419
 - Inquiries 51, 67
 - Inquiry reservations 357
 - Installing the Software 6
 - Installing to a new computer 414, 417
 - Internet network connection 524
 - Inventory 559, 579, 581, 585
 - Accounting 565
 - Adding 585
 - Adjustment Report 557, 558
 - Adjustments 565
 - Automatic discounts 579
 - Average Cost 565
 - Bottle Desposit 579, 581
 - Classes 577
 - Cost accounting method 572
 - Cost of Goods Sold 555
 - Discounts 579
 - Editing 585
 - Entering Adjustments 565
 - Filtering 550
 - Filtering sales lookup 593
 - Find items 549
 - General discounts 581
 - Importing 590
 - Item Classes 577
 - Item-specific discounts 581
 - On Hand Report 553
 - Ordering 559
 - Overview 577
 - Purchase orders 559
 - Purchases 565
 - Receiving 563, 565
 - Reporting 553, 555, 557, 558
 - Reports 551
 - Starting State 565
 - Surcharges 579, 581
 - Tracking 565
 - Transaction Categories 577
 - Vendors 578
 - Weighted Average Cost 565
 - Inventory Classes 577
 - Inventory Code 585
 - Inventory Items Setup 585
 - Inventory Sales 59
 - by amount 59
 - by quantity 59
 - Inventory Sales Reports 552
 - Invoices
 - Batch Printing 179
 - Printing 144
 - Types 146
 - IP address 523, 535
 - Item Specific Discounts 581
- J -**
- Javascript 270
 - Journal 181, 183, 184
 - Adding 184
 - Details 184
 - Editing 184
 - Viewing 183
- K -**
- Key Code 20, 277
 - Key Deposits 151
 - Keyboard Shortcuts 11
- L -**
- Label field 108

Labels
 Custom 467
 Leisure Interactive 206
 License 2, 29
 Linked Reservations 81, 82, 84, 86, 87, 90, 102
 List Queries 449
 Local variables 425
 Log files
 For networking 517
 Settings 369
 Log in
 Forgot password? 7
 Logging in or out 7
 Password reset 7
 Setup Operators 321
 Long-term Reservations 91
 Loss (Inventory) 565

- M -

Macros 436
 Creating 436
 Setup 436
 Using 436
 Magnetic stripe readers 382, 383
 Mailing Labels 25, 176
 Custom 467
 Main Menu 8
 Main window - tab views 30
 Maintenance 272
 Making Backups 15, 272, 414
 Managing Guests 109
 Maps 47, 325, 326
 Add/Edit Hotspot Dialog 332
 Add/Edit Indicator Dialog 332
 Color Key 28, 47
 Editing 326
 Image file 326
 Import and Export 325
 Options 47
 Setup 23, 325
 Site indicator attributes 326
 Tab View 47
 Mark sites clean 354
 Mark sites dirty 354
 Mass E-mail list 177
 Master Reservation 81, 87, 90
 McAfee SecurityCenter configuration 540
 MCPS Processing Options 392
 Memo
 Transaction Type 121
 Memorized Transaction Reports 59
 Menu Items
 Editing 490
 Menus 485, 490
 Creating 486
 Custom 485
 Editing 485, 487
 Editing Items 490
 Items 490
 Items List 489
 Levels 489
 Setup 486
 Sub-menus 489
 Merchandise discounts 579
 Merchandise Rates 292, 305
 Merchant Warehouse 382, 390
 MerchantWare Processing 382
 MerchantWare Processing Options 390
 Merging Customers 118
 Meter Readings
 Setup 25
 Setup Details 342
 Meters 170
 Entering Readings 148, 170
 Rates Setup 292
 Reading History 175
 Readings Lists 170
 Reports 170
 Setup 25, 281
 Setup Details 342
 Wrap-around setting 277
 Minimize to taskbar tray 29
 Misc. Income
 Entering Transactions 156
 Transaction Type 121
 Mixed-case formatting 355
 Monthly billing 91, 156
 Monthly billing settings 368
 Monthly Reservation Options 368
 Monthly Reservations 66, 91
 More Pref's 67
 Mouse Functions 10, 36
 Mouse-over text 36, 422
 Moving the data to a new computer 414, 417
 Moving the database 413

Moving transactions 155
 Multiple Databases 419
 Multi-Threading 182

- N -

Networking

Changing the Master computer 528
 Master change 528
 Master computer failure 528
 Master computer swap 528
 Server change 528
 Networking 517, 524, 526, 533, 535, 539
 Clearing record locks 535
 Client Diagnostics Dialog 536
 Command line parameters 526
 Connecting Progress Dialog 532
 Connecting to Server 535
 Error messages 521
 Firewalls 539
 Full Network Resync 533
 How it works 537
 Internet connections 524
 IP address 535
 IP address error 523
 Log files 517
 Maintenance functions 535
 McAfee firewall 540
 Multiple connections 526
 Norton Internet Security 540
 Not Connected 539
 Overview 517
 Remote connections 524
 Request full database refresh 532
 Requirements 517
 Router setup 524
 Server Diagnostics Dialog 537
 Setting Up 517
 Settings 529
 Show IP address 535
 Starting/Stopping 535
 Static IP 523
 Synchronizing 535
 Troubleshooting 533
 Troubleshooting Tips 521
 Verify the IP Settings 521
 View all record locks 535
 Windows Firewall 539

Working offline 535
 ZoneAlarm 539
 New Database 20, 406
 New End Date 95
 New Reservations Dialog 67
 New Start Date 95
 New version 275
 No Site:# message on the Rack 42
 Non-Reserved (Tab View) 51
 Non-Synchronized Reservations 81, 82, 84, 86, 87, 90
 Norton Internet Security 540
 No-Site Reservations 42, 51
 Notes entry 110
 Notice Message on Receipts & Invoices 376
 Notice text on Ticket form (Additional Notes) 277
 NSF checks 151

- O -

OAuth2 396
 Occupancy Report 167
 On Hand report 553
 On Site (Tab View) 50
 Online Reservation Handling 222
 Online Reservations 205, 228, 259, 261, 264, 267
 Confirming 264
 Conflicts 205
 Data Fields 209
 Data Fields Used 229
 Delete requests 259
 Details 264
 Downloading 261
 Duplicate Customers 264
 Editing 264
 Editing text 262
 E-mail Requests 230
 Entering Deposits 264
 Export to Web 229
 Friend 2-way 206
 Hercules 2-way operations 219
 Hercules 2-way setup 207
 Ignoring 262
 Inquiries 264
 Merging Customers 264
 Other Interfaces 228
 Overview 205
 Paste & Process 259

Online Reservations 205, 228, 259, 261, 264, 267
 Processing 262
 Re-process requests 259
 Request Fields 264
 Reservation Friend 2-way 206
 Retrieving 259
 Retrieving from E-mail 261
 Retrieving from Reservation Friend 261
 Saving 264
 Selecting Sites 264
 Setup (other interfaces) 228
 Site Availability 267
 Site Data Fields 213
 Site Fields 264
 Uploading Availability 267
 View recent requests 223
 Online Setup
 Batch E-mail options 402
 Open Previous Database 15
 Opening multiple databases 419
 Operators 7
 Access Levels Setup 324
 Changing password 7
 Logging in or out 7
 Setup 21, 321
 Orphaned reservations 412
 Orphaned transactions 411
 Other Online Interfaces 232, 241, 249
 Directories Used 232
 E-mail Connections 232
 Example Parsing Set 249
 Export to Web 231
 FTP settings 231
 General Setup 231
 Importing Rules 238
 Javascript example 270
 Parsing Engine 236
 Parsing Example 249
 Parsing Rules 236, 240, 241
 Parsing Sets 236, 237, 238
 POP3 Settings 232
 Pseudo-fields 241
 Site Data Fields 234
 Testing Parsing Rules 239
 Web page form example 271
 Other Reports 162
 Overdue Payments 52
 Owner reservations 66, 67

- P -

Pad Types Pick List 345
 Park Notes Setup 277
 Parks
 Authorization Code 20
 Filtering for Reports 31
 Key Code 20
 Park Information 20
 Setup 277
 Parsing 236
 Parsing Engine 241
 Parsing Rules 240
 Example 249
 Parsing Sets 236
 Example 249
 iCal samples 258
 Paste & Process Online Request 259
 Pasting Data 14
 Payments 137
 Categories 128, 137
 Categorizing 63
 Entering Transactions 137
 Payment Methods Pick List 345
 Transaction Type 121
 Transferring 143
 Payments Due (Tab View) 52
 PC Charge Processing Options 393
 PCCharge 393
 PCI Compliance
 Credit Cards 394, 395
 PDAs (Exporting to Palm
 Pocket PC) 193
 Pencil-in 357
 Pencil-In reservations 67
 Percentage Discount 542
 Pick Lists 21
 Custom 509
 Inventory Classes 577
 Setup 345
 User-defined 509
 Point of Sale 154
 Point of Sale (see POS) 541
 Pole Display Setup 570
 Pop-up Tips 36
 POS 585, 593
 Access levels 577

- POS 585, 593
 - Bar codes 542
 - Cash register 542
 - Continuous entry 542
 - Cost accounting method 572
 - Customer account 548
 - Data fields 576
 - Discounts 542, 579
 - Enter Item Price dialog 548
 - Enter item Qty 548
 - Filtering sales lookup 593
 - Find Inventory 549
 - Find receipt 161
 - Functions 542
 - General discounts 581
 - Hardware selection 569
 - Importing Inventory & Vendors 590
 - Inventory 577
 - Inventory Data 585
 - Inventory Filter 550
 - Inventory reports 551
 - Merchandise filtering 593
 - Non-Taxable 585
 - Overview 541
 - Percentage discount 542
 - Pick Lists 577
 - Pole Display 570
 - Printing options 574
 - Printing Vendor Labels 564
 - Program Options 572
 - Purchase orders 559
 - Refunds 542
 - Reports 551
 - Reservation account 548
 - Returns 547
 - Sales entry 542
 - Same Category 542
 - Scanning 542
 - Setup 568
 - Tax Exempt 585
 - Temporary Operator Override 542
 - Vendors 578
 - Voids 542
 - Possible Duplicate Customers 76
 - Postal-code lookup 67, 112
 - Postal-code lookup settings 367
 - Print Memo
 - Transaction Type 121
 - Printer Setup
 - Receipt printer 377
 - Receipt printer direct to port 379
 - Printing 144
 - Batch-printing receipts & invoices 179
 - Black & White 27
 - Options 370
 - Printer Setup 25
 - Printing Receipts 144
 - Refresh Printer Setup 25
 - Reports 41, 163
 - Reset all Printer configurations 25
 - Tab Views 41
 - Transactions 144
 - Profiles (iCal) 253, 254
 - Program Options 355
 - Prompt Options 360
 - Pseudo-fields 241
 - Public Documents 413
 - Purchase Orders 559
 - Filtering 563
 - Finding 563
 - Printing 562
 - Receiving 563
 - Settings 575
 - Purge old data 406
- Q -**
- Queries 448, 449, 452, 458
 - Columns 452
 - Cross-Table 458
 - Editing 449, 452, 458
 - Elements 452
 - Export 449
 - Fields 452
 - Filtering 456
 - Import 449
 - List Queries 449
 - Overview 448
 - Setup 449
 - Sorting 455
 - Testing 458
 - Queries Tab View 54, 448
 - Quick-Add Fields (to Dialogs) 497
 - QuickBooks 590
 - Exporting to 194
 - Importing Customers from 189

QuickBooks 590
 Importing Inventory 590
 Importing Vendors 590
 Quick-Info text 422
 Quick-Info Windows 36
 Quick-Reports 59
 Quote/Confirmation 103

- R -

Rack 42, 45
 "No Site" 45
 Days shown 45
 Hiding names 45
 Label 108
 Options 45
 Red line 42, 45
 Starting date 42, 362
 Tab View 42
 XXXX cells 45
 Rack, Default filter 31
 Rack, Site filter 31
 Rates 291, 294, 305
 Auto-rates 301
 Auto-Rates order 303
 Categories for Transactions 345
 Checking 67
 definitions 294
 Editing 294
 Examples 305
 Hourly 91
 Import and Export 291
 Merchandise 305
 Meter readings 305
 Monthly billing 156
 Order 303
 Rate Type default 148
 Seasonal 294
 Selecting 148
 Setup 24, 291
 Taxes 287
 Types 292
 Raw Data 409
 User-defined Tables 509
 Receipt Printer 25, 146, 371
 Direct to Port Settings 379
 Driver Settings 377
 USB Settings 377
 Receipt printer models 382, 383
 Receipts 376, 467
 Additional Notes Setup 277
 Batch Printing 179
 bottom text 376
 Credit Card Settings 374
 Custom 467
 Editing 467
 E-mail confirmations 396, 403
 E-mail Text 403
 E-mailing 147
 Find receipts 161
 Notice text 376
 POS options 574
 Print settings 371
 Printer Settings 377, 379
 Printing 144
 Types 25, 146
 Receipts by Category 59
 Receipts by Category Report 63
 Receipts by Payment Method 59
 Receiving Inventory 565
 Receiving Purchase Orders 563
 Record List Dialog 512
 Red line on the Rack 42
 Refresh Printer Setup 25
 Refunding Hercules Reservations 222
 Refunds
 Entering Transactions 141
 Error - Exceeds sales cap 141
 Issuing 128
 Transaction Type 121
 Refunds - POS 547
 Re-installing the software 414, 417
 Relationships
 User-defined 513
 Reminders
 Editing 339
 Setup 335, 336
 Types 338
 vs. Restrictions 335
 Remote access 524
 Rename Database 275
 Rental Rates 292, 294
 Repair bad links 413
 Reporting 124
 Reports 25, 59, 114, 162, 163, 167, 176, 448
 Adjustment Detail 557

- Reports 25, 59, 114, 162, 163, 167, 176, 448
 - Adjustment Summary 558
 - Alerts 182
 - Arrivals 49
 - Arrivals Statistics 167
 - Audit Trail 186
 - Availability 167
 - Balances due 52
 - Batch Printing Receipts 179
 - Common Dialog Controls 163
 - Common reports 162
 - Cost of Goods Sold 555
 - Custom Queries 448
 - Customer E-mail list 177
 - Customer Warnings 118
 - Customers 116
 - Daily receipts 162
 - Daily sales 162
 - Defining 448
 - Departures 49
 - Departures Statistics 167
 - E-mail list 177
 - Envelopes 25, 176
 - Exporting 42, 193
 - Exporting Lists 163
 - Filtering Reservations for Reports 179
 - Filtering Sites 31
 - Financial 59, 63, 155
 - Fixing Uncategorized 63
 - Housekeeping 166
 - How-Heard 169
 - Inventory 551
 - Inventory on hand 553
 - Inventory Sales 552
 - Journal 183
 - Mailing Labels 25, 176
 - Meter readings 170
 - Monthly sales 162
 - Non-reserved 51
 - Occupancy 167
 - On Site 50
 - Payments Due 52
 - Print settings 370
 - Printing 41, 163
 - Quick-reference 162
 - Rack 42
 - Receipts by Category 63, 155
 - Receipts by Category (allocations) 128, 137
 - Reservation E-mail list 177
 - Reservation History 114
 - Reservation orphans 412
 - Reservations 110
 - Reservations by date made 111
 - Sales Tax 287
 - Sales Tax reporting 162
 - Sizing Fields 41
 - Sorting 40
 - Tab View Options 34
 - Tab Views 30
 - Taxable Sales 287
 - Transaction History (Customer) 114
 - Transaction History (Reservation) 103
 - Transaction orphans 411
 - Transactions 55, 59, 63, 155
 - Unassigned Reservations 51
 - Unfulfilled Reservations 169
 - Waiting List 51
 - Work Orders 185
 - Z-out 162
- Reports Menu 162
- Request a full database refresh 532
- Reservation Details Dialog 103
- Reservation Friend
 - Retrieving Requests 261
- Reservation Friend 2-way 206
- Reservation Label Field 108
- Reservation Options 362
- Reservation Types 66
- Reservation Types Pick List 345
- Reservations 66, 67, 81, 86, 87, 90, 91, 98, 102, 103, 137, 146, 156, 205, 333, 357
 - Annual 91
 - Auto-checkout 77
 - Automatic site selection 87
 - Auto-Rates recalculation 132
 - Batch checkout 77
 - Canceling 96
 - Can't Book 67
 - Changing Customers 96, 103
 - Changing Dates 95
 - Changing Sites 95
 - Changing the customer 90
 - Check In 67
 - Checking In 76
 - Checking out 77
 - Checking Rates 67

- Reservations 66, 67, 81, 86, 87, 90, 91, 98, 102, 103, 137, 146, 156, 205, 333, 357
 - Color Key 28
 - Confirmation letters 98
 - Confirming 97
 - Conflicting 412
 - Conflicting with Online 205
 - Day Passes 94
 - Defaults 364
 - Deleting 103
 - Deposits (auto) 316
 - Double-Click action 357
 - Duplicate customers 76
 - E-mail confirmation 98
 - E-mailing 177
 - Extended stay 156
 - Filtering for Reports 179
 - Finding 110, 111
 - Free Stay 66
 - Group deposits 137
 - Groups 81, 82, 84, 86, 87, 90, 102
 - Guarantee 67
 - Guaranteeing 98
 - Guest Type 109
 - Hourly 23, 66, 91, 333
 - Importing 29, 189
 - Inquiry 357
 - Linked 81, 82, 84, 86, 87, 90
 - Linked (auto-rates) 132
 - Linking 102
 - Linking mode 82, 84, 86, 87
 - Long-Term 91
 - Master 81, 90
 - Monthly 66, 91
 - Monthly billing 156
 - Monthly Options 368
 - New 67
 - Non-Synchronized 81, 82, 84, 86, 87, 90
 - Normal 66
 - Notes 110
 - Online Conflicts 205
 - Online Requests 205
 - Owner 66
 - Pencil-in 67, 357
 - Print settings 373
 - Qty field 87
 - Quote / Confirmation 103
 - Rack (Vacancy Grid) 42
- Rates 291
- Receipt Types 25, 146
- Receipts (batch) 179
- Reminder Editing 339
- Reminder Types 338
- Reminders 335
- Restriction Editing 339
- Restriction Types 338
- Restrictions 335
 - Scheduled 81, 87, 90, 333
 - Schedules 23, 91
 - Seasonal 91
 - Site preferences 67
 - Splitting 100
 - Splitting a group deposit 137
 - Sub-member 81, 82, 84, 86, 87, 90
 - Swapping Sites 95
 - Synchronized 81, 82, 84, 86, 87, 90, 102
 - Temporary Operator Override 67, 103
 - Ticket Form 146
 - Transaction History 103
 - Transactions 78, 152
 - Types 67, 345
 - Unassigned 111
 - Unlinking 84
 - Viewing Details 103
 - Waiting List 67
- Reset all Printer configurations 25
- Resetting the database 406
- Restore Database 272, 274, 414, 417
- Restrictions
 - Editing 339
 - Setup 335, 336
 - Types 338
 - vs. Reminders 335
- Reversing credit cards 142, 393
- Rig Types Pick List 345
- Right-click
 - Custom menus 485
- Right-Click Functions 10, 36
- Rounding Change Due to 5 cents 357
- Reservations
 - Reminders Setup 336
 - Restrictions Setup 336
- Running The Software 6

- S -

- Sales Tax reporting 287
- Save & Test Queries 458
- Scanning bar codes 542
- Scheduled Reservations 81, 87, 90, 91, 333
- Schedules 23
- Screen resolution (for maps) 326
- Scripts 438
 - Creating 438
 - Example 438
 - Setup 438
 - Using 438
- Searching tab views 11, 40
- Seasonal Rates 294
- Seasonal Reservations 91
- Secondary auto-backup 369
- Security Deposits 151
- Security Setup 394
- Select Customer for POS transactions 548
- Select Reservation for POS transactions 548
- Selecting Forms 485
- Selecting Rates 148
- Send E-mail Form 147
- Setting Up Your Campground 15
- Settings 232, 277, 367, 375
 - Accounting method 572
 - Audit Trail options 187
 - Auto-backup location 369
 - Auto-Rates 301, 365
 - Backup location 369
 - Cash Drawer 380
 - Check In/Out times 277
 - Colors 28
 - Cost accounting 572
 - Cost of Goods Sold method 572
 - Credit Card MCPS options 392
 - Credit Card MerchantWare options 390
 - Credit Card PC Charge options 393
 - Credit Card Processing 384
 - Credit Card Processor 382, 383
 - Credit Card Security 394
 - Credit Card XpressLink options 386
 - Data Fields 350
 - Database 369
 - Debit Cards 389
 - Duplicate Customer Checking 365
 - E-mail 396
 - E-mail Connections 232
 - E-mail Reservation Requests 230
 - Envelopes 375
 - Export to Web 229
 - Fonts 355
 - Formats 355
 - Functions 357
 - GMail 396
 - Labels 375
 - Map View 47
 - Meter wrap-around 277
 - Monthlies 368
 - Network 529
 - OAuth2 396
 - Online Connections - General 231
 - Online Site Data Fields 234
 - Operator access levels 324
 - Parsing Rules 240
 - Parsing Sets 238
 - Pick Lists 345
 - Pole display 570
 - POP3 232
 - POS 572
 - POS receipts 574
 - Postal-code lookup 367
 - Print offsets 375
 - Printer Setup 25
 - Printing 370
 - Prompts 360
 - Purchase Orders 575
 - Rack 45
 - Rates examples 305
 - Receipt messages 376
 - Receipt Printer Port 377, 379
 - Receipts 371
 - Reports 370
 - Reservation Receipts 373
 - Reservations 362
 - Sites 279, 281
 - SMTP 396
 - Tab Views 34
 - Taxes 287
 - Ticket Form Additional Notes 277
 - Transactions 361
 - Web page upload 231
 - Zip-code lookup 367
- Setup 333

- Setup 333
 - Hercules 2-way 207
 - Hourly Reservations 23, 333
 - Maps 325
 - Other Online Interfaces 228
 - Periods 91
 - POS 568
 - Rates for Hourly 91
 - Schedules 23, 91, 333
 - User-defined Relationships 514
 - User-defined Tables 509, 512
 - Setup Checklist 18
 - Setup Dialogs 494
 - Setup Event Actions 506
 - Setup Forms 467
 - Setup Menus 486
 - Shared Documents 413
 - Shifts
 - Changing 405
 - Enabling 22, 350
 - Report 405
 - Show current database location 413
 - Show Dates 128, 151
 - Show Details 128
 - Show IP Address 535
 - Sign in
 - Logging in or out 7
 - Setup Operators 321
 - Site Classes
 - Filtering for Reports 31
 - Pick List 345
 - Site Filtering Dialog 31
 - Site Locking errors 225
 - Site Preferences 67
 - Site Types
 - Filtering for Reports 31
 - Pick List 345
 - Sites 279, 281, 345
 - Add/Insert Multiple 279, 281
 - Blocking dates 279
 - Check in/out times 281
 - Classes Setup 345
 - Deleting 279, 281
 - Dirty flag 354
 - Dirty flag options 357, 360
 - Double-click actions 357
 - Filtering for Reports 31
 - Make Unavailable 279
 - Meter wrap-around 281
 - Notes 110
 - Online Data Fields 234
 - Online Reservation Fields 229
 - Season Dates 281
 - Setup 23, 279, 281
 - Types Setup 345
 - Work Orders 184
 - Sizing Report Fields 41
 - SMTP setup 396
 - Sorting Hierarchy 455
 - Sorting Reports 40
 - Split a reservation 100
 - Splitting Deposits 137
 - Statements
 - Batch Printing 179
 - bottom text 376
 - Printing 144
 - Static IP address 523
 - Status Bar 8, 27
 - Sub-Member Reservations 81, 82, 84, 86, 87
 - Sub-menus 489
 - Summary Transaction Reports 59, 63
 - Support Information 1
 - Surcharges 581
 - Swap Sites 95
 - Synchronized Reservations 81, 82, 84, 86, 87, 90, 102
 - System Requirements 6
- T -**
- Tab Key
 - Navigating Dialogs 13
 - navigating tab views 11
 - Tab Views 30
 - Access levels 422
 - Arrivals 49
 - Common Controls 30
 - Content 422
 - Custom 54
 - Date Selection 30
 - Departures 49
 - Double-click actions 422
 - Exporting 42
 - Map 47
 - Mouse Functions 36
 - Mouse-over text 422

- Tab Views 30
 - Names 422
 - Non-Reserved 51
 - On Site 50
 - Payments Due 52
 - Printing 41
 - Queries 54
 - Quick-Info text 422
 - Rack 42
 - Report Options 34
 - Searching On 40
 - Setup 422
 - Sizing Fields 41
 - Sorting 40
 - Tip Text 422
 - Transactions 55
 - Unassigned 51
- Tabbed view options 355
- Tab-delimited files
 - Exporting to 193
 - Importing from 189
- Tables
 - User-defined 509, 513
- Taxes
 - Calculation 287
 - Categories 287
 - Changing Rates 287
 - Entering 287
 - Entering Transactions 136
 - Reporting 287
 - Setup 287
 - Taxable Sales 287
 - Transaction Type 121
- Taxes by Tax Category 59
- Taxes Setup 24
- Temporary Guests 94
- Temporary Operator Override 67, 103, 114, 128, 542
- Terminology 5
- Text Filtering 32
- Text Search 32
- T-Gate Processing Options 392
- Threads 182
- Ticket Form 146
 - Additional Notes setup 277
- Timed Actions 506
- Tip of the Day 10
- Tip Text 36, 422
- Toolbar 8, 27
- Transaction Categories 345
- Transactions 55, 57, 59, 124, 128, 134, 137, 143, 151, 156, 411
 - Accounts Receivable 59
 - Adding 120
 - Allocating Payment Categories 128
 - Auto-rates 132
 - Back-Dating 151
 - Balance Charges & Payments 59
 - Basics 78
 - Bounced checks 151
 - by amount 59
 - by quantity 59
 - Categories Pick List 345
 - Change date 151
 - Charge Entry 134
 - Charges by Category 59
 - Credit Cards 382, 394, 395
 - Credit Entry 134
 - Customer 154
 - Customer POS 542
 - Deposit Account 59
 - Deposit Entry 137
 - Deposit transfer 143
 - Deposits 124
 - Deposits (auto) 316
 - Deposits (security) 151
 - Detail Reports 55, 59
 - Discount Entry 134
 - Discounts by Discount Used 59
 - Editing and Deleting 128
 - Entering 124
 - Entering charges 78
 - Entering Individual 134
 - Expense 156
 - Exporting to QuickBooks 194
 - Filtering for Reports 57
 - Grid-Entry 144
 - History 155
 - History (Customer) 114
 - History (Reservation) 103
 - Importing 189
 - Income & Expenses 59
 - Key deposits 151
 - Memorized Reports 59
 - Misc. Income 156
 - Monthly billing 156

Transactions 55, 57, 59, 124, 128, 134, 137, 143, 151, 156, 411
 Moving 155
 NSF checks 151
 Options 361
 Order 155
 Orphaned transactions 411
 Payment Categories 128, 137
 Payment Entry 137
 Payment transfer 143
 POS 542
 Post-dated 57
 Post-dating 124, 361
 Quick-Reports 59
 Rates 291
 Recalling 128
 Receipts by Category 59, 63
 Receipts by Payment Method 59
 Recommended procedures 124
 Refund Entry 141
 Refunds 128
 Repairing orphans 411
 Report Filters 57
 Reporting 124
 Reports 55, 155
 Reservation 78, 152
 Reservation POS 542
 Security deposits 151
 Split Payment Categories 137
 Summary Reports 59, 63
 Tab View 55
 Tax Entry 136
 Taxes by Tax Category 59
 Temporary Operator Override 128
 Transactions Dialog 128
 Transfers 143
 Types 121
 Unbound 154
 Working with 120
 Transactions Options 361
 Transferring to a new computer 414, 417
 Triggering Events 506

- U -

Unassigned (Tab View) 51
 Unassigned Reservations 42, 51, 111
 Unbound Transactions 154

Uncategorized 63
 Unfulfilled Reservations Report 169
 Unit Types mapping 215
 Upgrading 275
 User-defined Relationships 513
 Editing 514
 Setup 514
 User-defined Tables 509, 513
 Data Fields 511
 Editing 511, 512
 Setup 509, 512
 Users 7
 Changing password 7
 Logging in or out 7
 Setup Operators 321

- V -

Vacancy Grid
 Web Page Javascript example 270
 Web Pages 267
 Vacancy Grid (Rack) 42
 Variables 425
 Vendors 564, 578
 Adding 578
 Finding 578
 Importing 590
 Printing Envelopes 564
 Printing Labels 564
 Setup 578
 View all record locks 535
 View Product Authorizations 29
 Voiding credit cards 142
 Voiding sales 542

- W -

Waiting List 51, 67
 Warning Flags Report 118
 Water Meters
 History 175
 Rates Setup 292, 305
 Readings entry & report 170
 Setup 25, 281
 Setup Details 342
 Wrap-around setting 277
 Web form

- Web form
 - Examples 249
- Web Pages
 - Exporting to 267
 - Exporting to -- Javascript example 270
- Web Pages (Uploading) 231
- Web site
 - Javascript example 270
 - Reservation form example 271
- Weighted Average Cost 565
- Window Tag 357
- Window Tags 146
 - bottom text 376
- Windows Firewall 539
- Windows IP address 523
- Work Orders 181, 184, 185
 - Adding 185
 - Editing 185
 - Printing 185
 - Reporting 185
- Working with Customers 112
- Working with Reservations 66
- Working with Transactions 120

- X -

- X-Charge Processing 382, 386
- XpressLink Processing Options 382, 386

- Z -

- Zip-code lookup 67, 112
- Zip-code lookup settings 367
- ZoneAlarm configuration 539
- Z-out report (Receipts by Payment Method) 59